

CHEFMAN[®]

RJ04-4RV-V2T

DIGITAL VOLCANO[®]
WAFFLE MAKER

WITH PROGRAMMABLE CRUNCH FACTOR PRESETS



CUSTOMER SERVICE: 888.315.6553 | customerservice@chefman.com

Congratulations on your purchase!

Every Chefman product is manufactured to the highest standards of performance and safety. We are confident that you will be so satisfied with your purchase that Chefman will be your go-to company for appliances in the future.

Customer satisfaction is a key element of our company's philosophy. The Chefman brand exists to fill a void on retail shelves and in consumer kitchens for a truly value-focused kitchen appliance. By questioning and adding value and innovation at every touch point in the manufacturer to end user journey, Chefman provides home chefs with the tools they need to achieve picture-perfect results with maximum efficiency. In addition to manufacturing appliances that are dependable, affordable and built with intuitive features to enhance your kitchen experience, we pride ourselves on providing top-of-the-line post purchase support, which includes complimentary access to ClubChefman.com for product tutorials, delicious recipes, how-to videos and access to our team of dedicated chefs.

Should a problem arise, each product is backed by a comprehensive manufacturer's 1-year warranty as well as outstanding after-sales service support through our dedicated customer service team. In the unlikely event that your product does not operate as described in the manual, please feel free to call or email our helpline for assistance. We understand that sometimes products can malfunction, so if you feel that your appliance is not operating as it should, warranty claims can be made within one year from the date of purchase when accompanied by a dated receipt.

This guarantee is in addition to your statutory rights; your statutory rights are not affected. This limited warranty does not apply in cases of damage caused by accident, improper use, abuse or force majeure.

This warranty gives you specific legal rights. Rights may vary depending on your state or province of residence. Some locations do not allow limitations on implied warranties or special incidental, or consequential damages, so the limitations may not apply to you. This limited warranty will be invalidated if the appliance is tampered with in any way whatsoever.

Our telephone helpline (888) 315-6553 is available for questions or technical assistance Monday through Friday, 9 am to 5 pm EST.

Customers can also receive support by emailing customerservice@chefman.com.



READ ALL INSTRUCTIONS BEFORE USE

For your safety and continued enjoyment of this product, always read the instruction manual before using.

CONTENTS

- 1** Introduction
- 2** Safety Instructions
- 5** Features
- 6** Operating Instructions
- 9** Tips
- 10** Cleaning and Maintenance
- 11** Terms and Conditions
- 12** Warranty Card

INTRODUCTION

The Digital Volcano Waffle Maker is designed to give you the ultimate waffle-making experience: Delicious waffles, with no mess to clean up! Simply make a batter and use the included measuring cup to pour the batter into the waffle maker spout. Select your crunch factor, press start and pour in the batter when the screen instructs you to. When the waffle is ready, the waffle maker will beep, indicating that your waffle is done cooking. Remove from waffle maker, add your favorite toppings and serve.

Enjoy incredible, Belgian style waffles, crispy golden brown on the outside and fluffy on the inside. With our special non-stick coating, cleanup is a breeze—no more scrubbing dried batter off of crusty plates.

Bon appétit!

SAFETY INSTRUCTIONS

IMPORTANT SAFEGUARDS

READ ALL INSTRUCTIONS.

THIS APPLIANCE IS FOR HOUSEHOLD USE ONLY.

WARNING: When using electrical appliances especially when children are present, basic safety precautions should always be followed to reduce the risk of fire, electric shock, and/or injury to persons, including the following:

1. The cord to this appliance should be plugged into a 120V AC electrical outlet only.
2. To protect against risk of electric shock, do not immerse the cord, plug or Waffle Maker in water or any other liquid.
3. Unit gets very hot. Do not touch hot surfaces. Use handles.
WARNING: Steam escaping from top of the Waffle Maker is hot. Keep hands clear of the immediate area surrounding the side vents and top of the Waffle Maker during operation.
WARNING: Use extreme caution when opening Waffle Maker once waffle is done cooking. Hot steam will escape and may cause burns.
4. This appliance should not be used by children.
5. Extreme caution must be exercised when any appliance is used near children.
6. Unplug Waffle Maker from wall outlet when not in use and before cleaning. Allow to cool before putting on or taking off parts, and before cleaning or storing.
7. Never yank the cord to disconnect the Waffle Maker from the outlet. Instead, grasp the plug and pull to disconnect.
8. Do not operate any appliance if the cord or plug is damaged. Do not use this Waffle Maker if it malfunctions, is dropped or has been damaged in any way. In order to avoid the risk of an electric shock, never try to repair the Waffle Maker yourself. In such cases, contact Chefman Customer Service for assistance.
9. The use of accessories or attachments not recommended by the manufacturer may cause fire, electrical shock, or injury.
10. Do not use outdoors or for commercial purposes.

SAFETY INSTRUCTIONS

11. Do not use this appliance for purposes other than the one for which it was designed.
 12. Do not let the electrical cord hang over the edge of the table or countertop, or touch hot surfaces.
 13. Do not place on or near a hot gas or electric burner or heated oven.
 14. Only use on a dry, flat, heat resistant surface.
 15. Use extreme caution when moving any appliance containing hot food, water, oil or other liquids.
 16. To disconnect, remove plug from outlet.
 17. Always unplug after use.
 18. **CAUTION: HOT SURFACES.** This appliance generates heat during use. Proper precautions must be taken to prevent the risk of burns, fire or other damage to persons or property.
 19. When using this appliance, provide adequate ventilation above and on all sides for air circulation. Do not allow this appliance to touch curtains, wall coverings, clothing, dish towels or other flammable materials during use.
 20. Use with wall outlet only.
 21. Never place the Waffle Maker in the dishwasher. This product cannot be immersed in water and is not dishwasher safe.
 22. The appliance is only to be operated in closed position.
 23. Spout must be locked into place on top of unit when using Waffle Maker.
- CAUTION:** This appliance is hot during operation and retains heat for some time after unplugging. Always use oven mitts when handling hot materials and allow metal parts to cool before cleaning. Do not place anything on top of the appliance while it is operating or while it is hot.
24. All users of this appliance must read and understand this User Guide before operating or cleaning this appliance.
 25. Do not leave this appliance unattended during use.

SAVE THESE INSTRUCTIONS

SAFETY INSTRUCTIONS

WARNING: This appliance has a polarized plug (one blade is wider than the other). To reduce the risk of electric shock, this plug is intended to fit into a polarized outlet only one way. If the plug does not fit fully into the outlet, reverse the plug. If it still does not fit, contact a qualified electrician. Do not attempt to modify the plug in any way.

SHORT CORD INSTRUCTIONS

A short power supply cord is provided to reduce the hazards resulting from entanglement or tripping over a longer cord. Longer detachable power-supply cords or extension cords are available and may be used if care is exercised in their use. If a longer detachable power-supply extension cord is used:

1. The marked electrical rating of the cord set or extension cord should be at least as great as the electrical rating of the appliance, and:
2. The cord should be arranged so that it will not drape over the countertop or tabletop where it can be pulled on by children or tripped over unintentionally.

POWER CORD SAFETY TIPS

1. Never pull or yank on cord or the appliance.
2. To insert plug, grasp it firmly and guide it into outlet.
3. To disconnect appliance, grasp plug and remove it from outlet.
4. Before each use, inspect the line cord for cuts and/or abrasion marks. If any are found, this indicates that the appliance should be serviced and the line cord replaced. Please return it to an authorized service representative.
5. Never wrap the cord tightly around the appliance, as this could place undue stress on the cord where it enters the appliance and cause it to fray and break.

DO NOT OPERATE APPLIANCE IF THE LINE CORD SHOWS ANY DAMAGE OR IF APPLIANCE WORKS INTERMITTENTLY OR STOPS WORKING ENTIRELY.

CAUTION: To ensure continued protection against risk of electric shock, connect to properly grounded outlets only.

IMPORTANT: During the first few minutes of initial use, you may notice smoke and/or a slight odor. This is normal and should quickly disappear. It will not recur after appliance has been used a few more times.

This appliance is not intended for use by persons (including children) with reduced physical, sensory or mental capabilities, or lack of experience and knowledge, unless they have been given supervision or instruction concerning use of the appliance by a person responsible for their safety.

FEATURES

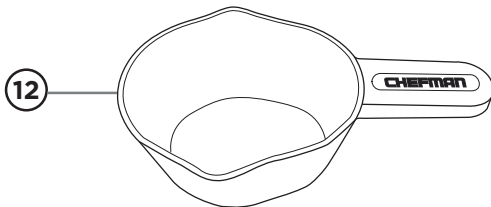
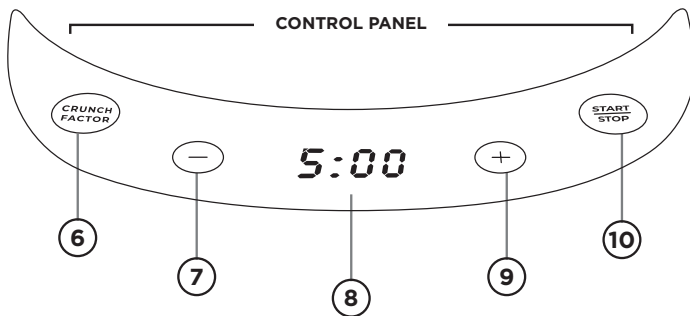
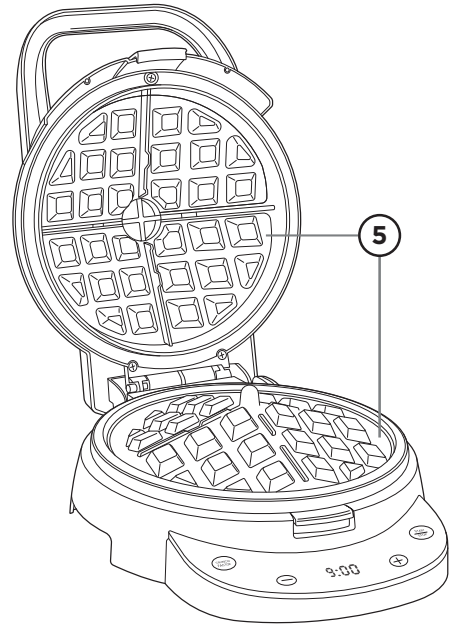
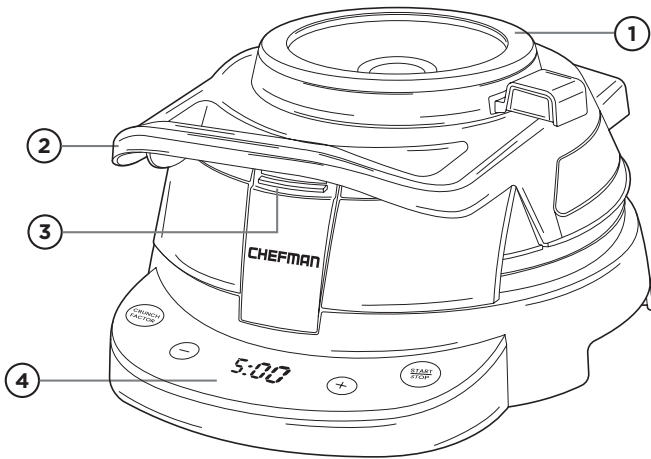

1. Pour Spout
2. Stay-Cool Handle
3. Latch Release Grips
4. Control Panel
5. Non-Stick Plates
6. Crunch Factor Button
7. Subtract Time Button
8. Digital Display
9. Add Time Button
10. Start/Stop Button
11. Cleaning Tool
12. Measuring Cup

OPERATING INSTRUCTIONS

BEFORE FIRST USE

Remove all packing materials and stickers from the inside and outside of the Waffle Maker. Gently wipe down the top and bottom plates with a damp cloth or paper towel. Dry completely. Never immerse the Waffle Maker, the cord or plug in water or any other liquids. Wash the measuring cup and cleaning tool with warm, soapy water and a sponge. Dry completely.

Set the Waffle Maker on a dry, flat, heat resistant surface.

Read all instructions and follow them carefully.

QUICK START GUIDE

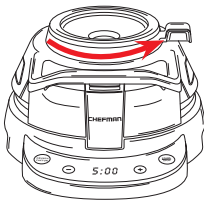

STEP 1
Make batter. Ensure that the pour spout is locked into place.

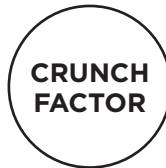

STEP 2
Plug in the Waffle Maker. Select CRUNCH FACTOR.

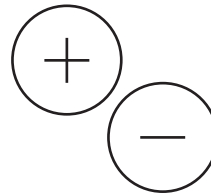

STEP 3
If desired, use the - and + buttons to adjust time.



STEP 4
Press START. The Waffle Maker will begin preheating.



STEP 5
When the digital display says "POr," use the measuring cup to pour in the batter. The timer will start counting down automatically.

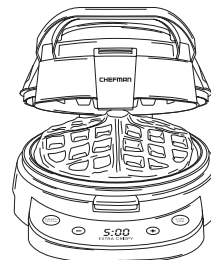

STEP 6
When the timer expires, the Waffle Maker will beep. Remove waffle.

OPERATING INSTRUCTIONS

HOW TO USE

Prepare waffle batter. For best results, use a thin batter. Thick batters may clog the pour spout and result in waffles that are not completely full. Thick waffle batters may often be thinned out by stirring a few more times. All batters vary.

Ensure that the pour spout is attached to the top of the Waffle Maker: The base of the pour spout should be inserted into the opening on the top of the Waffle Maker, and the handle should be aligned with the lock symbol.

Plug the Waffle Maker into a wall outlet. The screen will illuminate. Now, you have three options:

1. Press **START**.
2. Use the - and + buttons to adjust the time. Press **START**.
3. Press **CRUNCH FACTOR** to select Fluffy, Classic, Crispy or Extra Crispy presets. If desired, use the - and + buttons to adjust the time. Press **START**.

Once **START** is selected, the Waffle Maker will preheat.

When the Waffle Maker is fully heated, it will beep once and “POr” will display on the screen.

Use the included measuring cup to scoop the batter. Fill the measuring cup completely (180ml.)

NOTE: Never use non-stick spray on cooking plates. Non-stick spray will cause build-up over time, which may cause sticking. If desired, brush with a small amount of cooking oil instead, such as canola, vegetable or grapeseed.

In a thin, steady stream, pour the waffle batter into the pour spout. If the pour spout clogs, carefully use the measuring cup to scrape the extra waffle batter into the Waffle Maker.

NOTE: The handle of the measuring cup is designed to rest on the side of your bowl.

CAUTION: Never place your face or other parts of your body over the pour spout as the waffle is cooking or over the steam vents located on the side of the Waffle Maker. Hot steam escapes from the pour spout and vents during cooking and can potentially cause burns.

OPERATING INSTRUCTIONS

The Waffle Maker will automatically start counting down. When the timer expires, it will beep once and “OPn” will display on the screen. **Immediately check waffle.** If desired, **add 30 more seconds** to the timer by pressing the + button.

Carefully use your thumb to press the latch release grips. Use your other hand to lift the lid.

CAUTION: Hot steam may escape when lifting the lid. Keep your hands and face at a safe distance away to avoid potential burns.

Use silicone-tipped tongs to remove the cooked waffle and transfer to a plate. Serve immediately.

If not serving immediately, transfer cooked waffles to a sheet pan equipped with a wire rack—the wire rack will help prevent the waffles from getting soggy. Keep warm in a 200°F oven.

Before making subsequent waffles, use the silicone-tipped tongs to remove the excess batter from the pour spout. You may also use the cleaning tool. See “How to Use the Cleaning Tool” on page 8.

Unplug Waffle Maker when done to turn off completely.

HOW TO USE THE CLEANING TOOL

Use the flat end of the cleaning tool to scrape excess batter out of the pour spout. Twist the handle on the pour spout clockwise. Lift to remove.

Use the pronged side of the cleaning tool to push batter out of the bottom of the pour spout.

CAUTION: Pour spout is very hot.

The pronged side of the cleaning tool may also be used to push batter out of the windowpane located on the top of the waffle maker. Always push batter into the Waffle Maker while the Waffle Maker is in the closed position. Never use the cleaning tool on the Waffle Maker when it is in the open position. Plates are very hot and may cause burns.

TIPS

When making waffle mix, do not overmix. Whisk by hand, or use a mixer on very slow speed, just until large lumps disappear.

The optimal amount of batter to produce a full waffle varies based on brand and thickness of waffle batter.

Thin waffle batters work best. If waffle batter is too thick, it will clog the pour spout and result in a waffle that is not completely full. Thick waffle batters may often be thinned out by stirring a few more times.

If using mix-ins, such as nuts, chocolate or fruit, chop them very small (like the size of mini chocolate chips.)

We recommend using no more than a heaping tablespoon of mix-ins per cup of batter.

Using mix-ins may take some experimenting. Try mixing them into a single cup of batter at first, and baking one waffle at a time, until you perfect your ratio of mix-ins to batter.

Do not open Waffle Maker during the first minute of cooking; waffles will separate. For optimal results, allow waffle to cook completely by completing full cooking cycle. If top of Waffle Maker resists when attempting to lift it after cooking waffle, allow waffle to cook for longer in 30-second increments.

Never use non-stick spray on cooking plates. Non-stick spray will cause build-up over time, which may cause sticking. If desired, brush with a small amount of cooking oil instead, such as canola, vegetable or grapeseed.

For crispier, darker waffles, allow waffle to cook for longer.

Cake-based waffles are more tender than regular waffles and may require more care when removing from Waffle Maker. Use silicone-tipped tongs and a spatula for support. Waffle results will vary based on brand of waffle mix or recipe used.

Serve waffles immediately, or place on a sheet pan equipped with a wire rack—the wire rack will help prevent the waffles from getting soggy. Keep warm in a 200°F oven.

Cooked waffles freeze well. Cool completely and wrap in wax paper. Transfer to a sealed plastic bag or wrap in aluminum foil. Reheat waffles in a toaster, toaster oven or oven.

CLEANING AND MAINTENANCE

Unplug Waffle Maker when done. Cool completely. Use a soft bristle brush, such as a pastry brush, or paper towel to brush away crumbs from the plates.

The Waffle Maker does not disassemble for cleaning. Gently wipe down the exterior and interior plates (if necessary) with a damp cloth or paper towel.

To remove batter that has cooked onto the plates, pour a small amount of cooking oil onto the hardened batter. Allow to set for 5 minutes, then wipe off. Never use coarse scouring pads or steel wool.

Never immerse the Waffle Maker, the cord or the plug in water or any other liquids. The pour spout is removable. The pour spout and measuring cup may be washed with warm, soapy water and a sponge.

Always allow all parts to dry completely.

Never wrap the cord tightly around the Waffle Maker. Do not put any stress on cord where it enters the unit.

Store in a cool, dry place.

TERMS & CONDITIONS

Limited Warranty

CHEFMAN® warrants, subject to the conditions stated below, that from the date of purchase, this product will be free from mechanical defects for a period of ONE (1) year. CHEFMAN®, at its option, will repair or replace this product found to be defective during the warranty period. Should this product become defective by reason of improper workmanship or material defect during the specified warranty period, CHEFMAN® will repair or replace the same effecting all necessary parts replacements for a period of one year from the date of purchase. If product is no longer available we will replace it with a product of equal value. Transportation charges on parts, or products in whole, submitted for repair or replacement, under this warranty, must be borne by the purchaser. This warranty is void if the product is used for other than single-family household use or subjected to any voltage and waveform other than as specified on the rating label (e.g., 120V ~ 60 Hz).

This warranty is available to consumers only. You are a consumer if you own a CHEFMAN® product that was purchased at retail for personal, family or household use. Except as otherwise required under applicable law, this warranty is not available to retailers or other commercial purchasers or owners.

CONDITIONS: This warranty is valid for the original USA and Canada retail purchaser from the date of initial retail purchase and is not transferable. Keep the original sales receipt. Proof of purchase is required to obtain warranty service or replacement. Dealers, service centers, or retail stores do not have the right to alter, modify or in any way, change the terms and conditions of this warranty. Warranty registration is not necessary to obtain warranty on CHEFMAN® Products. Save your proof of purchase receipt.

ABOUT YOUR PRODUCT WARRANTY: Most warranty repairs are handled routinely, but sometimes requests for warranty service may not be appropriate. For example, warranty service would NOT apply if the product damage occurred because of misuse, lack of routine maintenance, shipping, handling, 3rd party warehousing or improper installation. Similarly, the warranty is void if the manufacturing date or the serial number on the product has been removed or the equipment has been altered or modified. During the warranty period, the authorized service dealer, at its option, will repair or replace any part that, upon examination, is found to be defective under normal use and service.

NORMAL WEAR: This warranty does not cover normal wear of parts or damage resulting from any of the following: negligent use or misuse of the product; improper voltage or current; use contrary to the operation instructions; deviation from instructions regarding storage and transportation; repair or alteration by anyone other than CHEFMAN® or an authorized service center. Further, the warranty does not cover Acts of God, such as fire, flood, hurricanes and tornadoes. CHEFMAN® shall not be liable for any incidental or consequential damages caused by the breach of any express or implied warranty. Except to the extent prohibited by applicable law, any implied warranty of merchantability or fitness for a particular purpose is limited in duration to the duration of the above warranty. Some states, provinces or jurisdictions do not allow the exclusion or limitation of incidental or consequential damages or limitations on how long an implied warranty lasts, so the above limitations or exclusion may not apply to you. This warranty gives you specific legal rights, and you may also have other rights that vary from state to state or province to province.

HOW TO OBTAIN WARRANTY SERVICE: If your CHEFMAN® product should prove to be defective within the warranty period, we will repair it, or if we think necessary, replace it. To obtain warranty service, simply email customerservice@chefman.com or call our toll-free number 1-888-315-6553 for additional information from our Customer Service Representatives, or send the defective product to Customer Service at Chefman, 200 Performance Drive, Mahwah, NJ 07495.

This warranty is effective for the time periods listed above and subject to the conditions provided for within this policy.

CALIFORNIA RESIDENTS ONLY:

California law provides that for In-Warranty Service, California residents have the option of returning a nonconforming product (A) to the store where it was purchased or (B) to another retail store which sells CHEFMAN® products of the same type. The retail store shall then, at its discretion, either repair the product, refer the consumer to an independent repair facility, replace the product, or refund the purchase price less the amount directly attributable to the consumer's prior usage of the product. If the above two options do not result in the appropriate relief to the consumer, the consumer may then take the product to an independent repair facility if service or repair can be economically accomplished. CHEFMAN® and not the consumer will be responsible for the reasonable cost of such service, repair, replacement, or refund for nonconforming products under warranty.

CHEFMAN® is a registered trademark of RJ BRANDS, LLC.

WARRANTY



DIGITAL VOLCANO®

WAFFLE MAKER

WITH PROGRAMMABLE CRUNCH FACTOR PRESETS

CHEFMAN®

All data fields are required in order for us to process your request:

Model Number: _____

Full Name: _____

Address: _____

Phone: _____ Email: (if applicable) _____

Date of Purchase*: _____

*We recommend you keep the receipt with this warranty card

Retail Store of Purchase: _____

Description of Malfunction:

Return your completed warranty card to:

RJ Brands
200 Performance Drive
Suite 207
Mahwah, NJ
07495

DIGITAL VOLCANO®

WAFFLE MAKER

WITH PROGRAMMABLE CRUNCH
FACTOR PRESETS

MODEL:
RJ04-4RV-V2T

888.315.6553

customerservice@chefman.com

Phone lines available Monday to Friday, 9am-5pm EST
1-YEAR LIMITED WARRANTY

MODEL: RJ04-4RV-V2T

12

CHEFMAN[®]



CLUBCHEFMAN.COM | CHEFMAN.COM | @MYCHEFMAN