

Applications

Make	Model	Year	
Ford	Transit	2000-2016	TDCi ECONetic HDT Sport HDi TDdi Di TD4
	Mondeo	2000-2007	
	Tourneo Custom	2012-2016	
	Transit Custom	2012-2016	
	BT-50	2012-2016	
Land Rover	Defender	2006-2011	
Mazda	BT-50	2012-2016	
Jaguar	X-Type	2003-2010	
Citroën	Relay/Jumper III	2006-2014	
Peugeot	Boxer III	2006-2012	

Engine Code	
2.0	FMBA/B, HJBA, HJBB, HJBC, HJBE, N7BA, N7BB, SDBA, D5BA, D6BA, ABFA, D3FA, F3FA, F1FA, FMBA/B
2.2	CYFA, CYFB, DRFA, DRFB, P8FA, P8FB, PGFA, PGFB, QVFA, QVFA, SRFA, SRFB, SRFD, SRFE, UHFA, CYFC, DRFC, CVF5, CVFF, CYF5, CYFF, CYFG, DRF5, DRFF, DRFG, CVR5, CYR5, DRR5, UHR5, USR6, UYR6, QJBA, QJBB, QJBC, QJBD, UHFB, MZ-CD, BG, QJBA (BG), 4HG (P22DTE), 4HH (P22DTE), 4HJ (P22DTE), 4HM (P22DTE), 4HU (P22DTE), 4HV (P22DTE), P22DTE (4HU), P22DTE (4HV)
2.4	D2FA, D2FB, D4FA, D4FA, F4FA, FXFA, H9FA, H9FB, H9FD, JXFA, JXFC, PHFA, PHFC, 244DT
3.2	SAFA, SAFB, MZ-CD

Our products are designed to be used correctly and with care for the purpose for which they are intended. No liability is accepted by Sonic for incorrect use of any of our products, and Sonic cannot be held responsible for any damage to personnel, property or equipment when using the tools. Incorrect use will also invalidate the warranty.

If applicable, the applications database and any instructional information provided has been designed to offer general guidance for a particular tool's use and while all attention is given to the accuracy of the data no project should be attempted without referring first to the manufacturer's technical documentation (workshop or instruction manual) or the use of a recognised authority such as Autodata.

It is our policy to continually improve our products and thus we reserve the right to alter specifications and components without prior notice. It is the responsibility of the user to ensure the suitability of the tools and information prior to their use.

SONIC

equipment

Instructions

Engine Timing & Fuel Pump Setting Kit

Ford, LDV Diesel - 2.0, 2.4



829050 - Engine Timing & Fuel Pump Setting Kit

Description:
The 829050 kit has been developed specifically for the Ford/LDV/ Jaguar 2.0lt, 2.2lt, 2.4lt and 3.2 lt diesel engines.

Components

Ref	Comp	OEM	Description
1	4880240	303-249-01	Fuel Pump Remover Leg Assembly x2
2	4880241	303-249-01	Central Plug For Pump Remover
3	4880296	303-682	Front Cover Alignment Tool - Ford
4	4880066	303-698	Flywheel Timing Pin
5	4880091		Setting Pin 6mm Diameter x2
6	4880279	303-705, 303-1093	Ford Oil Pump Alignment Tool
7	4880014	303-249-01	Puller Force Screw
8	4880013	303 249	Puller Beam
9	4880331		Hex Bolts (Puller) x4
10	4880191	303-679	Fuel Pump Cover Removal Tool
11	4880047		Washers x2
12	4880065	303-675	Flywheel Locking Pin
13	4880064	303-734	Flywheel Locking Pin (12 x 55)
14	4880090	303-732	Setting Pin (5mm)
15	4880096	303-735	Locking Pin (8mm)
16	4880144		Chain Tensioner Locking Pin 1.4mm
17	4880190	303-1151	Fuel Pump Pulley Holding Tool
18	4880273	303-1587	Crankshaft Setting Tool

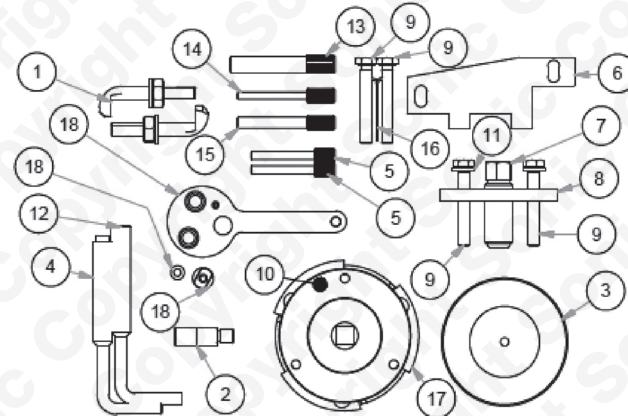

Instructions

The following instructions are for guidance only. Please refer to OEM derived data such as the vehicles manufactures own data or Autodata. The use of these engine timing tools is purely down to the user's discretion and Sonic cannot be held responsible for any damage caused what so ever.



Instructions

Component 1, 2, 7, 8, 9, 11 - Fuel Pump Pulley Puller
Use components (1, 2, 7, 8, 9 & 11) to pull the fuel pump pulley off the fuel pump and push the pump out. Use in combination with 10 and 18 to allow the pump to be removed without disturbing the camshaft drive chain. Early pulleys use the screw in legs (11), latter pulleys require the hooked legs (1)

Use component (10) to remove the fuel pump cover.

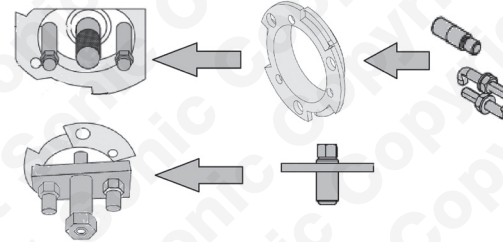

Components 3 & 10 - Front Cover Alignment Tool - Ford
Component 3 is used to align the front engine cover with the front crankshaft seal removed and all bolts loose. Use component 10 to remove old seal prior to alignment and to fit the new seal after alignment.



Component 4 & 12 - Flywheel Locking Pin
Component (4 & 12) are used to lock the flywheel in its timed position.

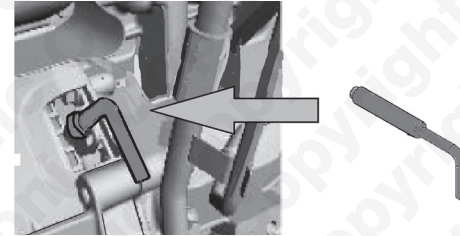

Component 5 - Camshaft Setting Pin x2

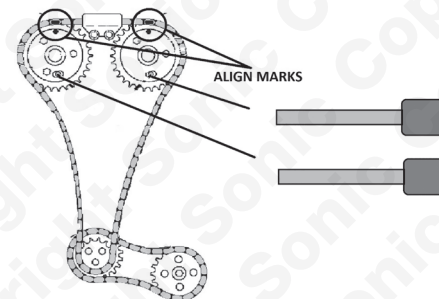

Component 6 - Ford Oil Pump Alignment Tool
Use to align the oil pump as shown.

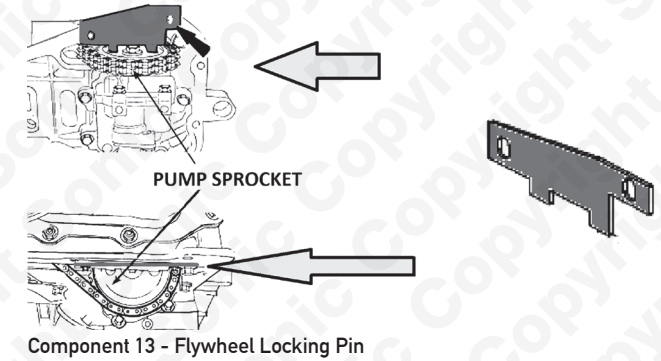

Component 13 - Flywheel Locking Pin

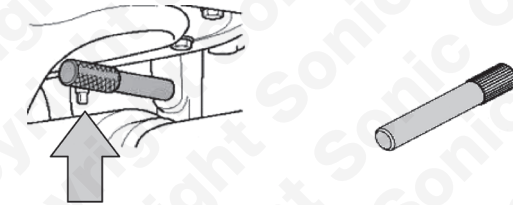

Component 14 - Camshaft Setting Pin (5mm)

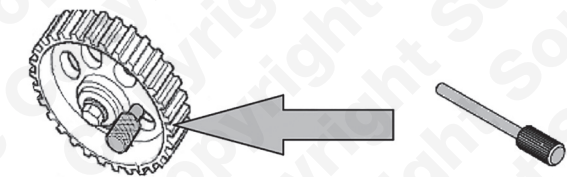

Component 15 - Locking Pin (8mm)

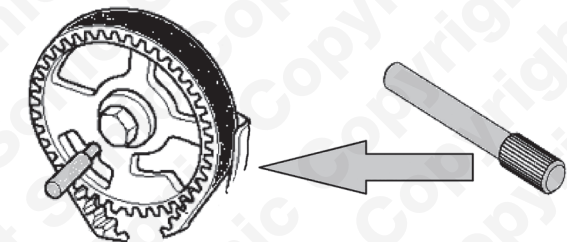

Component 18 - Crankshaft Setting Tool
Used to set and hold the crankshaft

