

## Applications

Make	Model	Year	Type
Peugeot	607	2004-2011	HDi TDV6
	407/Coupe	2004-2009	
Citroën	C5 III	2007-2009	
	C6	2005-2009	
Land Rover	Discovery 3	2004-2009	
	Discovery 4	2009-2013	
	Range Rover Sport	2005-2009	
Jaguar	S-Type	2004-2008	

## Engine Code

2.7	DT17TED4 (UHZ), UHZ (DT17BTED4), 276DT, 276DT (7B/7G)
-----	-------------------------------------------------------

Our products are designed to be used correctly and with care for the purpose for which they are intended. No liability is accepted by Sonic for incorrect use of any of our products, and Sonic cannot be held responsible for any damage to personnel, property or equipment when using the tools. Incorrect use will also invalidate the warranty.

If applicable, the applications database and any instructional information provided has been designed to offer general guidance for a particular tool's use and while all attention is given to the accuracy of the data no project should be attempted without referring first to the manufacturer's technical documentation (workshop or instruction manual) or the use of a recognised authority such as Autodata.

It is our policy to continually improve our products and thus we reserve the right to alter specifications and components without prior notice. It is the responsibility of the user to ensure the suitability of the tools and information prior to their use.

# SONIC

equipment

## Instructions

### Engine Timing Kit Jaguar Land Rover Diesel TDV6 - 2.7



## 829037 - Engine Timing Kit

### Description:

The 829037 Engine Timing Kit allows the valve timing to be set and maintained during cam belt replacement on the popular Jaguar/ Land Rover TDV6 diesel engine found across the Jaguar & Land Rover ranges. The 829037 also includes the additional PSA locking tools required for the 2.7 HDi engine found in the Citroen and Peugeot ranges.

## Components

Ref	Comp	OEM	Description
1	4880127	303-1132	Camshaft Sprocket Checking Pin
2	4880079	303-1126	Camshaft Sprocket Timing Pins x2
3	4880129	303-1116	Fly Wheel Locking Tool - Manual Transmission
4	4880128	303-1117	Fly Wheel Locking Tool - Auto Transmission
5	4880077	0195-K	Flywheel Locking Pin Peugeot/Citroen 0195-K
6	4880078	0195-C	Coolant Pump Pulley Pin Peugeot/Citroen 0195-C

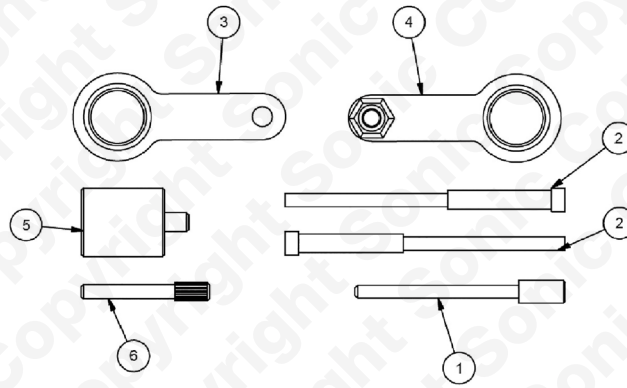

## Instructions

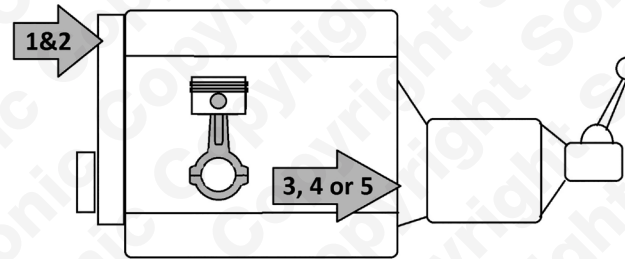

### Component Descriptions:

#### Component 1 - Camshaft Sprocket Checking Pin

Component 1 is used to check the alignment of the right hand camshaft pulley after fitting a new belt. See OEM instructions for detailed use.

#### Components 2 - Camshaft Sprocket Timing Pins X 2

Components 2 are used to lock the camshafts in their timed position as shown.

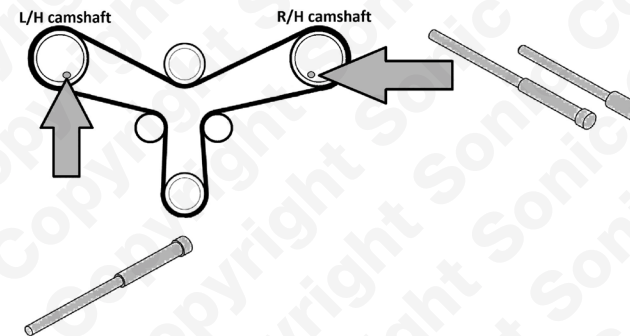

### Component 3, 4 & 5 - Fly Wheel Locking Tool

Components 3, 4 and 5 are all used to lock the flywheel in its timed positions.

3 - use on Jaguar and Land Rover vehicles equipped with manual transmission.

4 - use on Jaguar and Land Rover vehicles equipped with automatic transmission.

5 - use on Peugeot and Citroen models.

Fit as shown in place of the crankshaft position sensor.

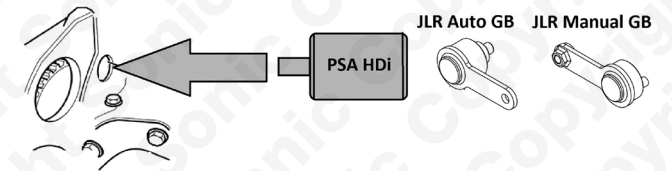

### Component 6 - Coolant Pump Pulley Pin (PSA)

Use component 6 to hold the water pump pulley while loosening the fixings to remove the pulley.

## Instructions

The following instructions are for guidance only. Please refer to OEM derived data such as the vehicles manufactures own data or Autodata.

The use of these engine timing tools is purely down to the user's discretion and Sonic cannot be held responsible for any damage caused what so ever.

