

# **Exway Flex Hub/Belt(2022) Exway Flex Hub/Belt ER User Manual**

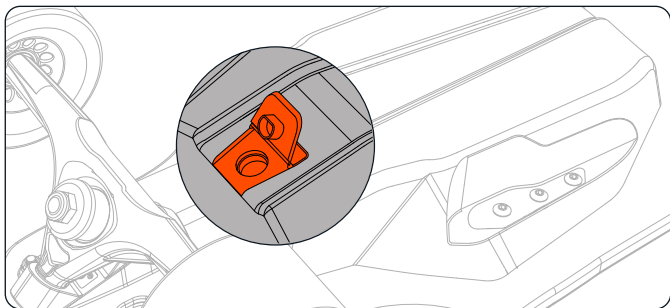

## 防水充电口

必须使用Flex 2022原装充电器进行充电。

(滑板充满电后,充电器指示灯转为绿灯,充电完毕必须盖好盖子,以保证防水性能。)

CHS

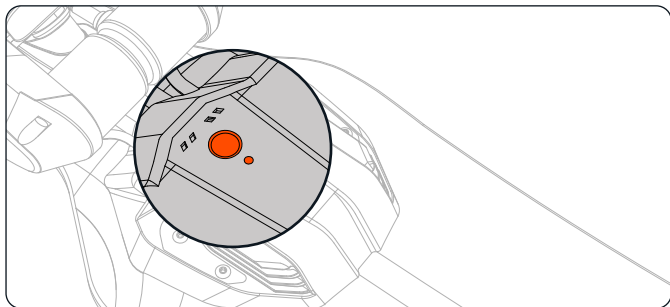

## 电源键开机

待机状态:使用遥控器控制开机,2小时后进入关机状态。(App可自定义待机时间)

关机状态:长按3秒电源键启动滑板。

## 滑板指示灯的操作和状态:

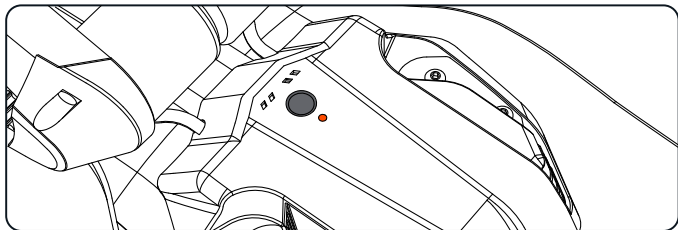

关机

长按电源键3s



绿灯常亮

正常工作状态



红灯常亮

充电中



配对

长按电源键8秒  
(滑板关机状态下)



红绿灯交替闪烁

配对模式



红灯闪烁

滑板未连接遥控器

## 遥控器操作方法:

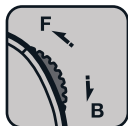
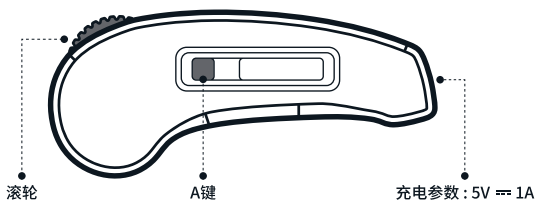

### 加速/刹车

向前推动加速  
向后推动刹车



### 开关机

长按3秒A键



### 设置模式

长按7秒A键  
(遥控器关机状态下)



### 切换档位

短按1次A键



### 定速巡航

固定油门连接2次A键



### 切换前进方向

连接3次A键



### 限速

连接6次A键



## 预警内容:

DISCONNECTED

4

遥控器断开连接

BOARD  
20%

滑板电量过低(20%)

BOARD  
10%

滑板电量过低(10%)

M

MOTOR SHORT

电机短路



ESC OVERHEAT ( I )

ESC 温度过高 (1级)



ESC OVERHEAT ( II )

ESC 温度过高 (2级)



MOTOR OVERHEAT

电机过热 (1级)



MOTOR OVERHEAT

电机过热 (2级)



HIGH VOLTAGE ( I )

滑板电压过高 (1级)



HIGH VOLTAGE ( II )

滑板电压过高 (2级)

# 安全须知&免责声明

1. 使用电动滑板与进行其他运动一样具有潜在的风险,可能造成伤害甚至死亡。
2. 使用前必须阅读使用说明书,并佩戴好护具。
3. 皮带在正常使用下会磨损,请参阅Exway相关教程视频,以正确更换损坏的皮带。
4. 请遵循当地交通法律法规,在允许范围内安全使用。
5. 14岁以下儿童、残疾人士、孕妇、老年人等,以及存在精神障碍、疾病、身体正常运动存在障碍的人群禁止使用。
6. 说明书与最终产品可能存在区别,具体请参考Exway App或官方网站提供的最新版本说明书。
7. 有关最新版本的产品手册,请参阅Exway应用程序或官方网站。
8. 若长时间不使用,请每30天对滑板进行一次充放电,以保证电池寿命。
9. 若滑板因使用不当导致损坏、开裂、进水等情况时,为了您的安全请通过购买渠道联系官网售后进行维修后再使用。

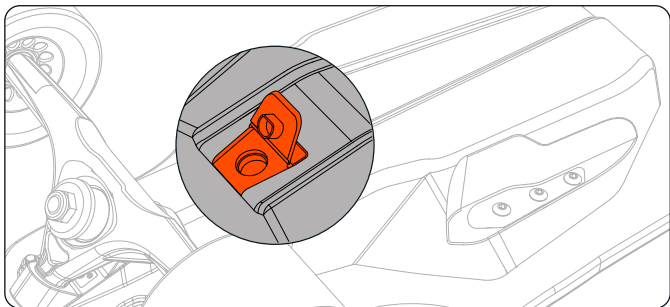

## Water Proof Charging Port

You must use Flex 2022 original charger for charging.  
(After the board is fully charged, the charger indicator will turn green, and the cover must be closed after charging to ensure waterproof performance.)

EN

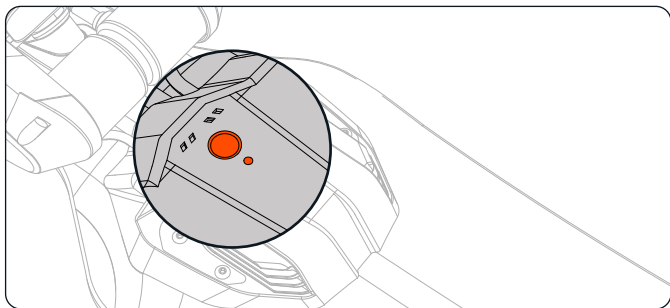

## Power button on

Standby mode: use the remote controller to power on the board , then it will automatically shut off after 2 hours. (Users can use the Exway app to customize the standby time)

Shutdown mode: Long hold the power button for 3 seconds to turn on the board.

## Indications:

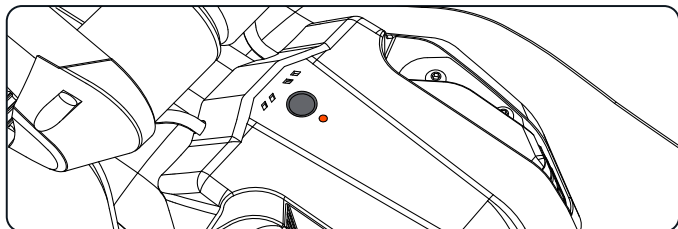

### Power on/of

Hold the button for three seconds



### Continuous green light

Board is turned on



### Continuous red

Charging



### Pairing

Long press for eight seconds to turn on pair mode when the board is turned off



### Red and green lights flashing

Pairing mode is activated



### Flashing red light

Remote not connected to the board

## How to operate the remote:

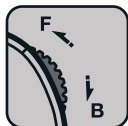
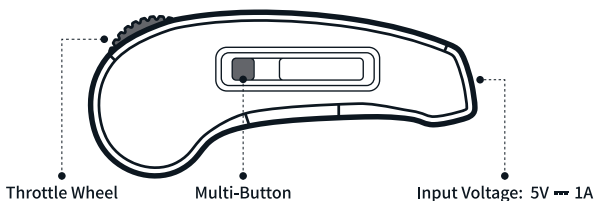

### Accelerate / Brake

Roll forward to accelerate  
Roll backward to brake



### Switch On/Off

Hold the Multi-Button for  
three seconds



### Setting Mode

Hold the multi-Button for 7  
seconds when the remote is  
turned off.



### Change Ride Mode

Short press the  
Multi-Button



### Cruise Control

Double press the Multi-Button while  
holding the throttle wheel



### Change Direction

Triple-press the  
Multi-Button



### Speed Limit Mode

Press the Multi-Button six  
times

## Warnings:

DISCONNECTED

4

The remote is disconnected from the Board



BOARD  
20%

The battery capacity is below 20%



BOARD  
10%

The battery capacity is below 10%



MOTOR SHORT

Motor Short



ESC OVERHEAT ( I )

Controller temperature is too high



ESC OVERHEAT ( II )

Controller is overheating, please stop using your board immediately!



MOTOR OVERHEAT

Motor temperature is too high



MOTOR OVERHEAT

Motors are overheating, please stop using your board immediately!



HIGH VOLTAGE ( I )

Voltage is too high



HIGH VOLTAGE ( II )

Voltage is too high, please stop using your board immediately!

# Warnings & Safety Information:

1. Whenever you ride an Exway board, you risk death or serious injury from loss of control, collisions, and falls. To ride safely, you must read and follow all warnings and instructions in this manual.
2. Always wear a helmet when riding. Never ride in water, wet surfaces, in the rain, slippery or uneven surfaces, steep hills, traffic, cracks, train tracks, gravel, rocks, or any obstacles that could cause a loss of traction. Avoid night riding, areas with poor visibility, and narrow spaces.
3. Do not ride an Exway board in environments, on inclines, or at speeds where you would not be safely in control of an unpowered skateboard. In the event of wireless interference or battery fault, you may need to rely on skating techniques like foot-braking or sliding to stop.
4. Please ride responsibly and respect those around you. How you ride will determine how people view this new mode of transportation.
5. The version of the user manual may not be up to date, check out the Exway App or [www.exwayboard.com](http://www.exwayboard.com) to read the most up-to-date version
6. Belts do wear out while riding, make sure to check out instruction videos from Exway to swap your belts properly.
7. If you do not use your board for long periods, please discharge and recharge your board every 30 days.
8. In the event the Skateboard sustains any accidental damage where any of the main structural components are cracked or the Skateboard is subjected to water penetration of electrical components. It is the responsibility of the owner to contact the dealer or an Authorized Exway service center for the board to be thoroughly inspected prior to being ridden again.

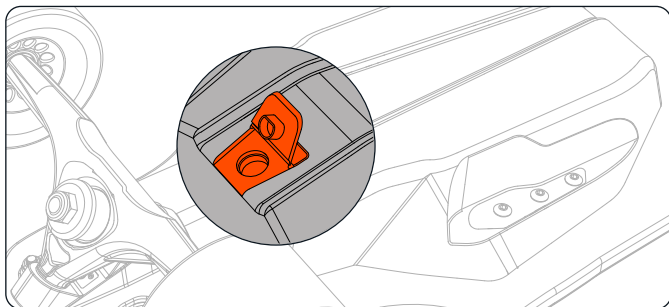

## Wassergeschützter Ladeanschluss

Verwenden Sie zum Aufladen des Boards ausschließlich das originale Exway Flex SE Ladegerät.

Die vollständige Akku-Aufladung zeigt das Ladegerät mit grüner LED an. Bringen Sie die Schutzkappe korrekt auf um den Schutz vor Wasser zu gewährleisten.

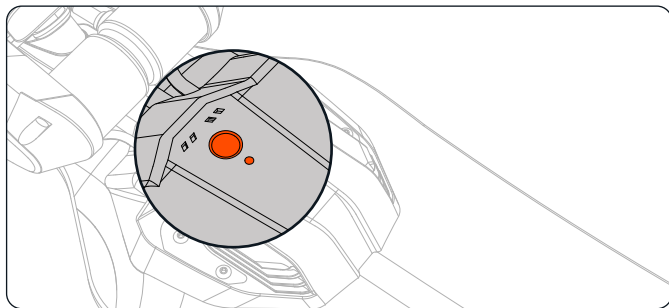

## Das Board einschalten

Sie können das Board während der Standby-Modus mit die Remote einschalten. In der Grundeinstellung wird sich das Board nach zwei Stunden ohne Benutzung ausschalten. Sie können die Einstellungen in das App ändern.

Drücken Sie den Knopf für drei Sekunden um das Board zu einzuschalten.



## Anzeigen:

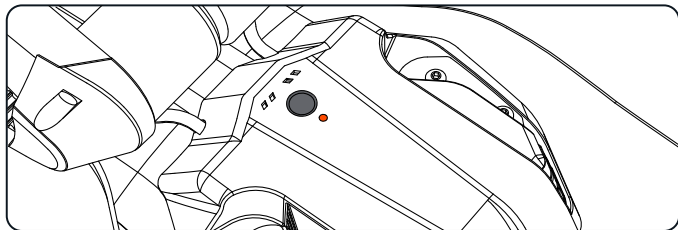

**Power an/aus**

Drücken Sie den Knopf für drei Sekunden



**Kontinuierliche grüne Anzeige**    **Kontinuierliche rote Anzeige**

Board ist eingeschaltet



Laden



**Pairing**

Taste 8 Sekunden gedrückt halten um den "Pair-Mode" zu starten



**Rote und grüne Anzeige blinken**

"Pairing-Mode" ist aktiv



**Blinkende rote Anzeige**

Fernbedienung nicht mit dem Board verbunden

## Verwendung der Fernbedienung:

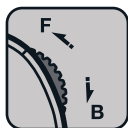
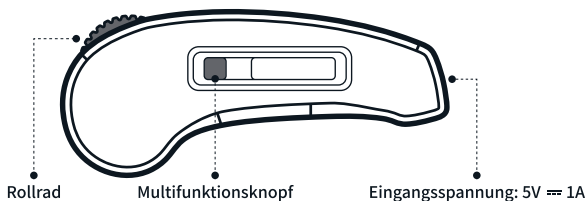

### Beschleunigung / Bremsen

Rad nach vorne drehen um zu beschleunigen  
Rad nach hinten drehen um zu



### Ein- / Ausschalter

Multifunktions-taste für drei Sekunden halten



### Einstellmodus

Multifunktions-taste für sieben Sekunden drücken um den Einstellmodus zu starten



### Fahrmodus ändern

Multifunktions-taste kurz drücken



### Tempomat

Multifunktions-taste doppelklicken während das Einstellrad halten



### Richtungswechsel

Multifunktions-taste drei Mal drücken



### Geschwindigkeitsbegrenzer-Modus

Multifunktions-taste sechs Mal drücken

## Warnings:

DISCONNECTED

4

Die Fernbedienung ist nicht verbunden

BOARD  
20%

Ladezustand der Batterie unter 20%

BOARD  
10%

Ladezustand der Batterie unter 10%



MOTOR SHORT

Motor-Kurzschluss: Die Motor-Anschlüsse auf korrekte Position überprüfen



ESC OVERHEAT ( I )

Board-Controller heiß



ESC OVERHEAT ( II )

Board-Controller überhitzt: Umgehend das Board nicht mehr benutzen!



MOTOR OVERHEAT

Motortemperatur zu hoch



MOTOR OVERHEAT

Motor überhitzt: Umgehend das Board nicht mehr benutzen!



HIGH VOLTAGE ( I )

Batteriespannung zu hoch



HIGH VOLTAGE ( II )

Batteriespannung zu hoch: Umgehend das Board nicht mehr benutzen!

# Sicherheitshinweise:

1. Wenn Sie ein Exway-Board fahren, riskieren Sie Tod oder schwere Verletzungen durch Kontrollverlust, Kollisionen und Stürze. Um sicher zu fahren, müssen Sie alle Warnungen und Anweisungen in diesem Handbuch lesen und befolgen.
2. Tragen Sie beim Fahren immer einen Helm. Fahren Sie niemals auf Wasser, nassen Oberflächen, bei Regen, rutschigen oder unebenen Oberflächen, steilen Hügeln, Verkehr, Rissen, Bahngleisen, Kies, Steinen oder Hindernissen, die zu einem Traktionsverlust führen könnten. Vermeiden Sie Nachtfahrten, Bereiche mit schlechter Sicht und enge Räume.
3. Fahren Sie kein Exway-Board in Umgebungen, an Steigungen oder bei Geschwindigkeiten, bei denen Sie die Kontrolle über ein nicht angetriebenes Skateboard nicht sicher haben würden. Im Falle einer Funkstörung oder eines Batteriefehlers müssen Sie sich möglicherweise auf Skating-Techniken wie Fußbremsen oder Sliden verlassen, um anzuhalten.
4. Bitte fahren Sie verantwortungsbewusst und respektieren Sie die Menschen um Sie herum. Wie Sie fahren, bestimmt, wie die Menschen dieses neue Transportmittel sehen.
5. Die Version des Benutzerhandbuchs ist möglicherweise nicht auf dem neuesten Stand. Lesen Sie die Exway-App oder [www.exwayboard.com](http://www.exwayboard.com), um die aktuellste Version zu lesen.
6. Antriebsriemen verschleißen während der Fahrt! Verwenden Sie Anleitungsvideos von Exway, um zu überprüfen wie Sie die Riemen richtig ersetzen.
7. Wenn Sie Ihr Board längere Zeit nicht benutzen, entladen Sie es bitte alle 30 Tage und laden Sie es wieder auf.
8. Falls das Skateboard einen Unfallschaden erleidet, bei dem eines der Hauptbauteile gerissen ist oder Wasser in die elektrischen Komponenten eingedrungen ist. Es liegt in der Verantwortung des Besitzers, den Händler, bei dem das Board gekauft wurde, oder ein autorisiertes Exway Service Center zu kontaktieren, damit das Board vor der erneuten Fahrt gründlich inspiziert werden kann.

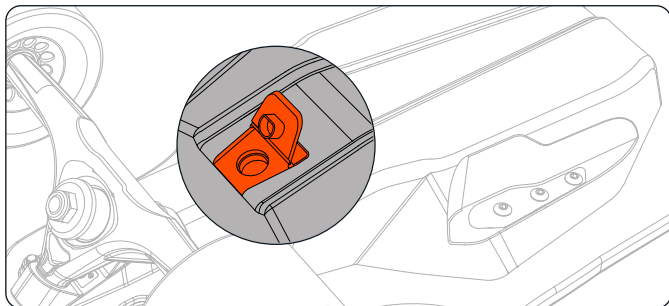

## Port de charge étanche

La charge doit être effectuée à l'aide d'un chargeur Flex se original.  
(une fois que la plaque coulissante est complètement chargée, l'indicateur du chargeur devient Vert, et le couvercle doit être recouvert après le chargement pour assurer l'étanchéité.)

FR

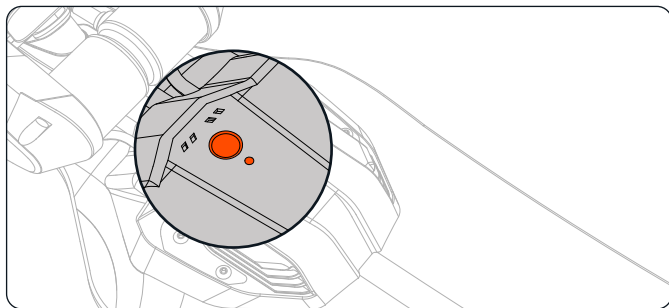

## Mise en marche avec le bouton d'alimentation

État de veille : utilisez la télécommande pour mettre en marche, et passez à l'état d'être éteint après 2 heures. (L'application peut personnaliser le temps de veille)  
État éteint : appuyez longuement sur le bouton d'alimentation pendant 3 secondes pour démarrer le skateboard.

## Fonctionnement et état de l'indicateur de skateboard:

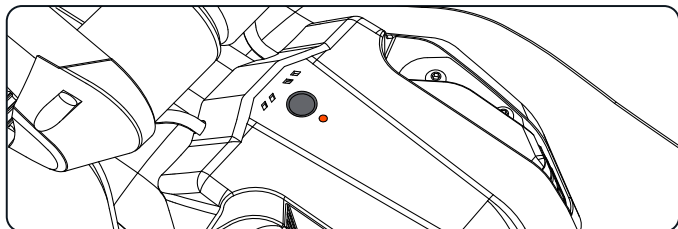

### Conversion de machine

Appuyez sur le bouton d'alimentation et maintenez-le enfoncé pendant 3 secondes



### Vert fixe

Conditions de travail normales



### La lumière rouge est toujours allumée

Charger



### Paire

Appuyez sur le bouton d'alimentation et maintenez-le enfoncé pendant 8 secondes (lorsque la planche à roulettes est éteinte)



### Les feux de signalisation clignent en alternance

Mode d'appariement



### Rouge clignotant

Le skateboard n'est pas connecté à la télécommande

## Comment fonctionne la télécommande:

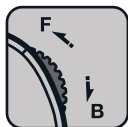
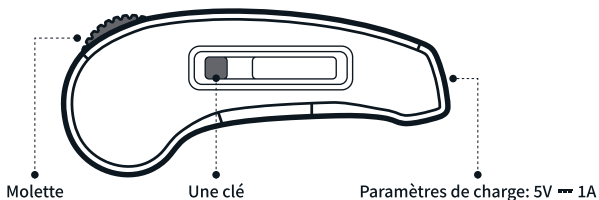

### Accélération / freinage

Avancez et accélérez  
Repousser le frein



### Conversion de machine

Appuyez sur le bouton A  
et maintenez-le enfoncé  
pendant 3 secondes



### Mode de réglage

Appuyez sur le bouton A  
et maintenez-le enfoncé  
pendant 7 secondes  
(lorsque la télécom-  
mande est éteinte)



### Changement de vitesse

Appuyez une fois  
brièvement sur la touche A



### Régulateur de vitesse

Appuyez deux fois sur le bouton A  
pour verrouiller l'accélérateur



### Retournement

Appuyez 3 fois sur la  
touche A



### Limitation de vitesse

Appuyez 6 fois sur la  
touche A

## Contenu d'avertissement:

DISCONNECTED

4

Déconnexion de la télécommande

BOARD  
20%

Batterie de skateboard  
trop faible (20%)

BOARD  
10%

Batterie de skateboard  
trop faible (10%)

(M) MOTOR SHORT

Court-circuit du moteur



ESC OVERHEAT ( I )

Température ESC trop  
élevée (niveau 1)



ESC OVERHEAT ( II )

Température ESC trop  
élevée (niveau 2)



MOTOR OVERHEAT

Surchauffe du moteur  
(niveau 1)



MOTOR OVERHEAT

Surchauffe du moteur  
(niveau 2)



HIGH VOLTAGE ( I )

La tension de la planche à  
roulettes est trop élevée (niveau 1)



HIGH VOLTAGE ( II )

La tension de la planche à  
roulettes est trop élevée (niveau 2)



# Consignes de sécurité et avis de non-responsabilité

1. L'utilisation de planches à roulettes électriques présente les mêmes dangers potentiels que tout autre sport, ce qui peut entraîner des blessures ou même la mort.
2. Avant utilisation, assurez-vous de lire le manuel d'instructions et de porter un équipement de protection.
3. La courroie s'usant dans des conditions normales d'utilisation, veuillez vous référer à la vidéo du didacticiel Exway correspondante pour remplacer correctement la courroie endommagée.
4. Veuillez l'utiliser en toute sécurité dans la plage autorisée conformément au code de la route local.
5. Les enfants de moins de 14 ans, les personnes handicapées, les femmes enceintes, les personnes âgées, etc. qui ont des troubles mentaux, des maladies et des troubles normaux des mouvements physiques sont interdits d'utiliser le produit.
6. Il peut y avoir des différences entre le manuel et le produit final. Pour plus de détails, veuillez vous référer à la dernière version du manuel fournie sur l'application Exway ou sur le site officiel.
7. Pour obtenir la dernière version du manuel du produit, reportez-vous à l'application Exway ou au site Web officiel.
8. S'il n'est pas utilisé pendant une longue période, veuillez charger et décharger la planche à roulettes tous les 30 jours pour assurer la durée de vie de la batterie.
9. Dans le cas où la planche à roulettes subit des dommages accidentels lorsque l'un des principaux composants structurels est fissuré ou que la planche à roulettes est soumise à la pénétration d'eau dans les composants électriques. Il est de la responsabilité du propriétaire de contacter le revendeur où la planche est achetée ou un centre de service agréé Exway pour que la planche soit soigneusement inspectée avant de la réutiliser.

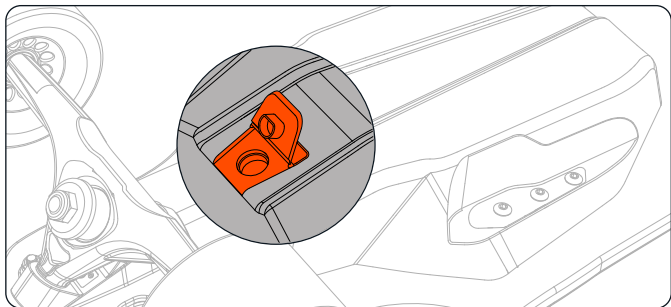

## 防水電気口

Flex 2022のオリジナル充電器を使って充電しなければなりません。  
(スケートボードが電気で満たされたら、充電器のパイロットランプが青になり、充電が終わったら必ずカバーを閉めて、防水性能を保証します。)

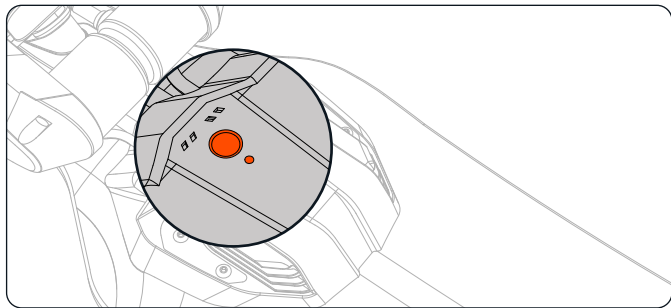

## 電源キーのオン

待機状態: リモコンを使って起動を制御し、2時間後にシャットダウン状態に入ります。アプリは待機時間をカスタマイズできます  
シャットダウン状態: 3秒の電源ボタンを長押ししてスライドを起動します。

## スケートボードインジケータの操作とステータス:

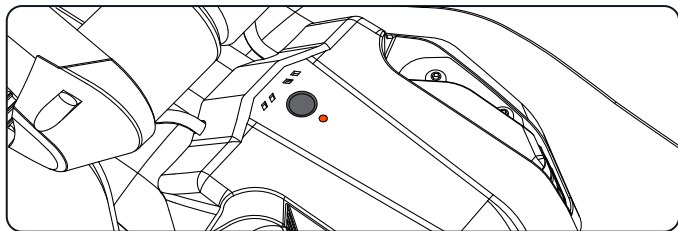

開閉機

TTL 電源長押し 3s



安定した緑色

通常の作業状態



赤信号は常に点灯しています

充電



ペア

電源ボタンを8秒間長押しします  
(スケートボードがオフの場合)



信号が交互に点滅します

ペアリングモード



赤く点滅

スケートボードがリモコンに  
接続されていません

## リモコンの操作方法:

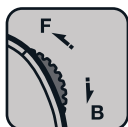
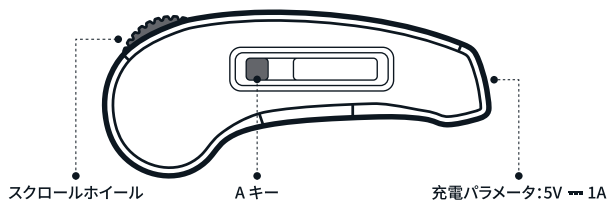

### 加速/ブレーキ

前進して加速する  
ブレーキを後方に押す



### スイッチマシン

Aボタンを3秒間長押し  
します



### モードを選択する

Aボタンを7秒間長押し  
します(リモコンがオフの場合)



### 開閉装置

Aキーを1回短く押す



### クルーズコントロール

Aボタンを2回押ししてスロットルを固定します



### 方向を切り替える

Aキーを3回押す



### 速度制限

Aキーを6回押す

## 警告内容:

DISCONNECTED

4

リモコンが切断されました

 BOARD  
20%

スケートボードのバッテリー  
が低すぎる(20%)

 BOARD  
10%

スケートボードのバッテリー  
が低すぎます(10%)

 MOTOR SHORT

モーター短絡

 ESC OVERHEAT ( I )

ESC温度が高すぎる(レベル1)

 ESC OVERHEAT ( II )

ESC温度が高すぎる(レベル2)

 MOTOR OVERHEAT

モーターの過熱(レベル1)

 MOTOR OVERHEAT

モーターの過熱(レベル2)

 HIGH VOLTAGE ( I )

スケートボードの電圧が高  
すぎる(レベル1)

 HIGH VOLTAGE ( II )

スケートボードの電圧が高  
すぎる(レベル2)

## 安全上の注意と免責事項:

1. 電動スケートボードの使用には、他のスポーツと同じ潜在的なリスクがあり、怪我や死亡の原因となる可能性があります。
2. 使用する前に、取扱説明書を読み、保護具を着用する必要があります。
3. ベルトは通常の使用で摩耗します。損傷したベルトを正しく交換するには、関連する Exway チュートリアルビデオを参照してください。
4. 地域の交通法規制に従い、許可された範囲内で安全に使用してください。
5. 14 歳未満のお子様、身体の不自由な方、妊婦、お年寄り等、精神障害、病気、正常な運動障害のある方のご利用はご遠慮ください。
6. マニュアルと最終製品は異なる場合があります。詳しくは、Exway アプリまたは公式サイトに掲載されている最新版のマニュアルをご覧ください。
7. 製品マニュアルの最新バージョンについては、Exway アプリまたは公式 Web サイトを参照してください。
8. 長期間使用しない場合は、バッテリーの寿命を延ばすために、30 日ごとにスケートボードを充電および放電してください。
9. スケートボード(本製品)が偶発的かつ思いがけない損傷を受けた場合、主要な構造部品のいずれかにひびが入ったり、電子部品に水が浸透してしまったりする場合があります。その場合、所有者には、スケートボード(本製品)をその状態のまま利用する前に、購入した際の販売店・ディーラー、もしくは公認の Exway サービスセンターへ連絡し、適切な検査を行う責任があります。

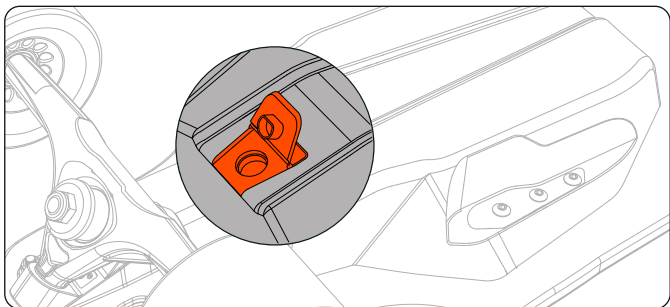

## 방수 충전 포트

Flex 2022오리지널 충전기를 사용해 충전해야 한다.  
 (스케이트보드가 충전되면 충전기 표시등이 녹색 등으로 바뀌고 충전이 끝나면 반드시 뚜껑을 잘 닫아 방수 성능을 확보해야 한다.)

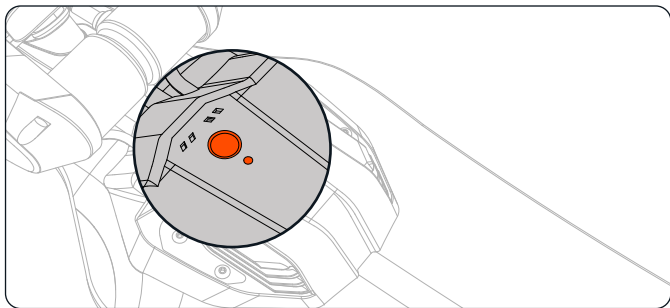

## 전원 키 작동

대기 상태: 리모콘으로 작동을 제어하고 2시간 후에 전원이 꺼지는 상태에  
 들어간다.(App에서 대기 시간을 사용자 정의할 수 있음)  
 전원 끄기 상태: 전원 버튼을 3초 동안 길게 누르면 스케이트보드가 작동됩니다.

## 스케이트 보드 표시기의 작동 및 상태 :

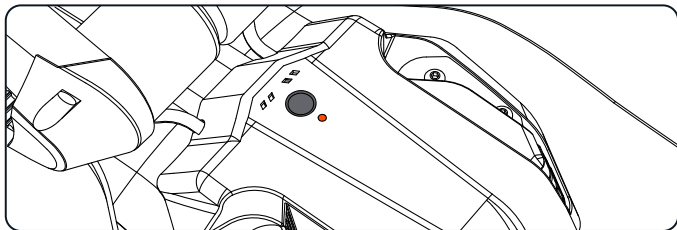

기계 전환

전원 버튼을 3 초 동안 길게  
누릅니다



녹색으로 계속 켜져 있음

정상적인 근무 조건



빨간불은 항상 켜져 있습니다

충전



쌍

전원 버튼을 8 초 동안 길게  
누릅니다  
(스케이트 보드가 꺼져있을 때)



신호등이 번갈아 깜박입니다

페어링 모드



빨간색으로 깜박임

스케이트 보드가 리모컨에  
연결되어 있지 않습니다



## 원격 제어 작동 방법 :

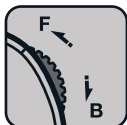
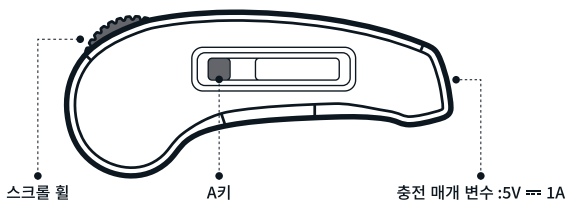

### 가속 / 브레이크

앞으로 나아가고  
가속화하십시오



### 기계 전환

A 버튼을 3 초 동안 길게  
누릅니다



### 설정 모드

A 버튼을 7 초 동안 길게  
누릅니다  
(리모컨이 꺼져있을 때)



### 기어 전환

A 키를 한 번 짧게 누릅니다



### 크루즈 컨트롤

A 버튼을 두 번 눌러 스톱들을  
고정하십시오



### 방향 전환

A 키를 3 번 누릅니다



### 속도 제한

A 키를 6 번 누릅니다

## 경고 내용:

DISCONNECTED

4

원격 제어 연결 해제

BOARD  
20%

스케이트 보드 배터리가 너무  
낮음 (20 %)

BOARD  
10%

스케이트 보드 배터리가 너무  
낮음 (10 %)

(M)

MOTOR SHORT

모터 단락



ESC OVERHEAT ( I )

ESC 온도가 너무 높습니다  
(레벨 1)



ESC OVERHEAT ( II )

ESC 온도가 너무 높습니다  
(레벨 2)



MOTOR OVERHEAT

모터 과열 (레벨 1)



MOTOR OVERHEAT

모터 과열 (레벨 2)

KR



HIGH VOLTAGE ( I )

스케이트 보드 전압이 너무  
높습니다 (레벨 1)



HIGH VOLTAGE ( II )

스케이트 보드 전압이 너무  
높습니다 (레벨 2)

# 안전 지침 및 면책 조항

1. 전기 스케이트 보드의 사용은 다른 스포츠와 동일한 잠재적 위험을 가지고있어 부상이나 사망까지 초래할 수 있습니다.
2. 사용하기 전에 사용 설명서를 읽고 보호 장비를 착용해야 합니다.
3. 정상적인 사용시 벨트가 마모되므로 관련 Exway 튜토리얼 동영상을 참조하여 손상된 벨트를 올바르게 교체하십시오.
4. 현지 교통 법규에 따라 허용 범위 내에서 안전하게 사용하시기 바랍니다.
5. 14 세 미만의 어린이, 장애인, 임산부, 노인 등 정신 장애, 질병, 정상적인 신체 운동에 장애가있는 분은 사용을 금합니다.
6. 매뉴얼과 최종 제품은 차이가있을 수 있으며 자세한 사항은 Exway App 또는 공식 홈페이지에서 제공하는 매뉴얼의 최신 버전을 참고하시기 바랍니다.
7. I제품 매뉴얼의 최신 버전은 Exway 앱 또는 공식 웹 사이트를 참조하세요.
8. KR 장시간 사용하지 않을 경우 배터리 수명을 보장하기 위해 스케이트 보드를 30 일마다 충전 및 방전하십시오.
9. 부적절한 사용으로 인해 스케이트보드가 파손, 금이 가거나, 침수 등 경우 발생시 안전을 위해 구매 채널을 통해 공식 홈페이지 애프터서비스로 연락주시면 접수후 수리하고 이용해 주시기 바랍니다.



## WARRANTY CARD

Name: \_\_\_\_\_ Telephone Number: \_\_\_\_\_

E-mail: \_\_\_\_\_

Address: \_\_\_\_\_

Serial Number: \_\_\_\_\_ Date of Purchase: \_\_\_\_\_

Purchased From: \_\_\_\_\_

### Issue:

- Unbootable     Charging     Problems while riding  
 Remote     Motor     Other(Truck/Gripe Tape/Wheels/Charger)

### Maintenance history:

- Have you taken it apart ?     Have you upgraded the firmware?  
 Was it ever water-damaged ?     Is the light on at the charging port ?

Description of the issue: \_\_\_\_\_  
\_\_\_\_\_

Exway's Feedback and Solution:

## Security Warning & Disclaimer

---

1. Please read and understand the user manual before riding your Exway electric skateboard. You are responsible for the operation and control of the electric skateboard and you must know how to control it before you ride.
2. Riding an Exway electric skateboard is extremely dangerous. Whenever you ride your Exway board you risk great bodily injury, disability, or death from loss of control, collision, or falls.
3. The Exway electric skateboard can lose connection with the remote control. If this happens the skateboard becomes a non-motorized longboard. Please always ride within your ability to control the board in case power loss occurs. Be prepared to lose braking ability at anytime.
4. Skate only in an open area free from vehicles and pedestrian traffic, and other physical obstacles. You are responsible for learning the basic features of the board such as braking, accelerating, and switching gears. Always wear a helmet and full protective gear while riding.
5. Do not ride on slippery or uneven surfaces. Only ride in areas with good visibility. Avoid riding in close proximity to vehicles and pedestrian traffic.
6. The Exway electric skateboard is not a toy and is not intended for children under 16.
7. Please refer to the Exway APP or the official website for the latest version of the product manual.

## Maintenance

---

1. When storing your Exway, the ideal battery level should be between 30% and 75%. If you are storing your board for long periods of time please charge and ride it at least once a month.
2. Do not place your Exway near an open fire or in areas where the temperature is exceedingly hot.
3. Do not store your Exway in wet or damp conditions in order to avoid short circuits and electrical malfunctions.

## Special Notes

---

1. The warranty is valid for 6 months and is non-transferable.
2. The warranty starts on the date the board is purchased. The customer must be able to provide proof of purchase and be within the 6 month purchase period.
3. Wear and tear items (grip tape, wheels, bearings, and rubber bushings) are not covered under warranty.
4. Damages caused by improper use, improper maintenance, improper storage, or unauthorized repairs will void the warranty.

NR



iOS



Android



Available on the  
App Store



Get it on  
Google Play

- ・ 扫描二维码下载APP获得电子版说明书
- ・ Scan QR code to download the App and get the most up-to-date version of the user manual.
- ・ Scannen Sie den QR-Code, um die App herunterzuladen und die aktuellste Version des Benutzerhandbuchs zu erhalten.
- ・ Scannez le code QR pour télécharger l'application afin d'obtenir la version électronique du manuel.
- ・ QRコードをスキャンしてAPPをダウンロードし、電子版のマニュアルを入手してください
- ・ QR 코드를 스캔하여 앱을 다운로드하여 매뉴얼의 전자 버전을 받으십시오.

---

**进阶设置/Find Us Here/Finden Sie uns hier/Réglages avancés/高度な設定/고급 설정**

Exway Store :  
[www.exwayboard.com](http://www.exwayboard.com)

Learn More :  
<https://www.youtube.com/channel/UCZ74glv3YkLdcz30dJE1flw>  
(YouTube Channel:Exwayboard)

(YouTube Channel:Exwayboard)

<https://space.bilibili.com/78880290/video>



**PANTONE Black 6 C**

(标题/深色)



**PANTONE Black 7 C**

(图案辅助色)



**PANTONE Cool Gray 10 C**

(正文/图案辅助色)



**PANTONE Cool Gray 3 C**

(图案辅助色)



**PANTONE 1655 C**

(logo色/强调色)

封面跟尾页二维码单面印刷 其他的双面印刷

尺寸:105\*147mm