

CLEANING & CARE

- Wipe regularly with a dry cloth.
- Do not use abrasive cleaners.
- Do not use chemical cleaners.
- Retain these instructions for reference.



RF
RENOVATION
FACTORY

D08000602300500

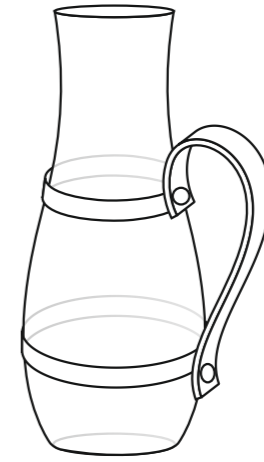

ASSEMBLY INSTRUCTIONS

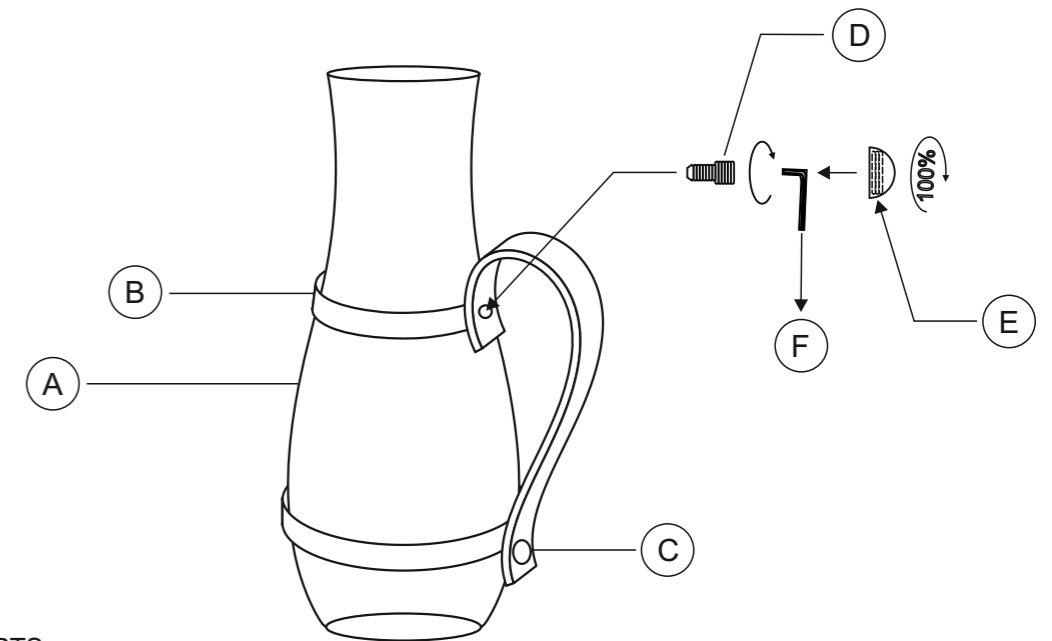

PARTS

A			Glass	1
B			Top Metal Ring	1
C			Bottom Metal Ring	1
D			Allen Screw	1
E			Button Cap	1
F			Allen Key	1

STEP 1

Place the top metal ring in the glass gently as show below .

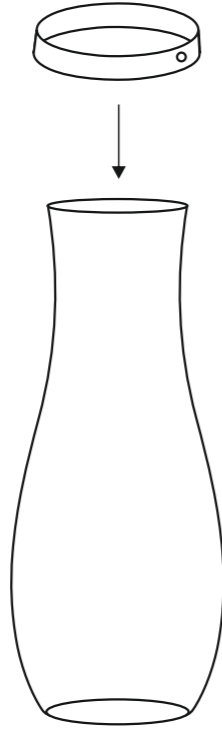

STEP 3

Align the holes, insert the allen screw in the metal hole and tighten by using allen key. Place the cap on the screw and tighten the button cap as shown below.

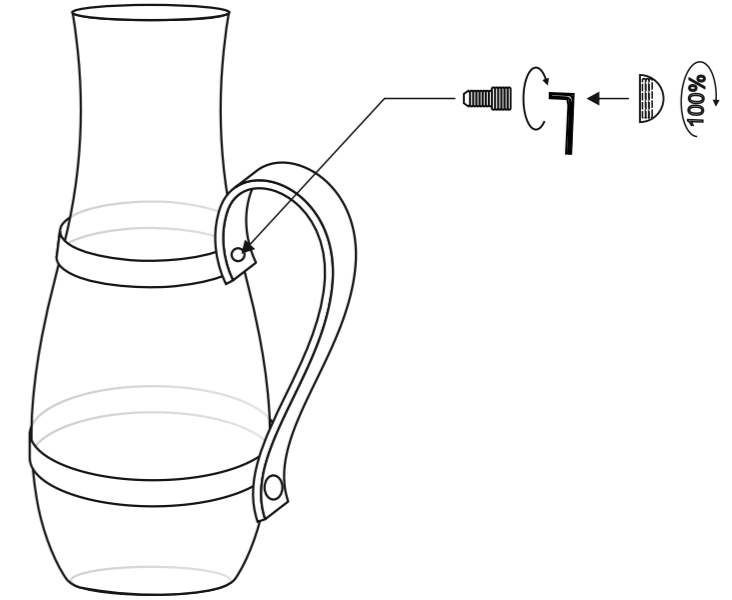

STEP 2

Place the bottom metal ring in the glass gently as show below

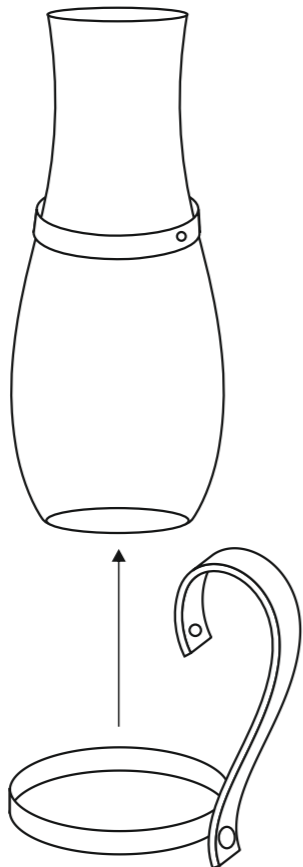

Final Product Image

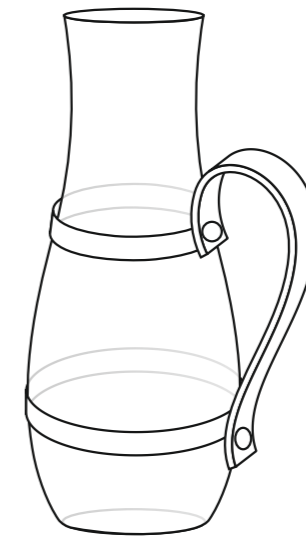

Now your product is ready for use.