

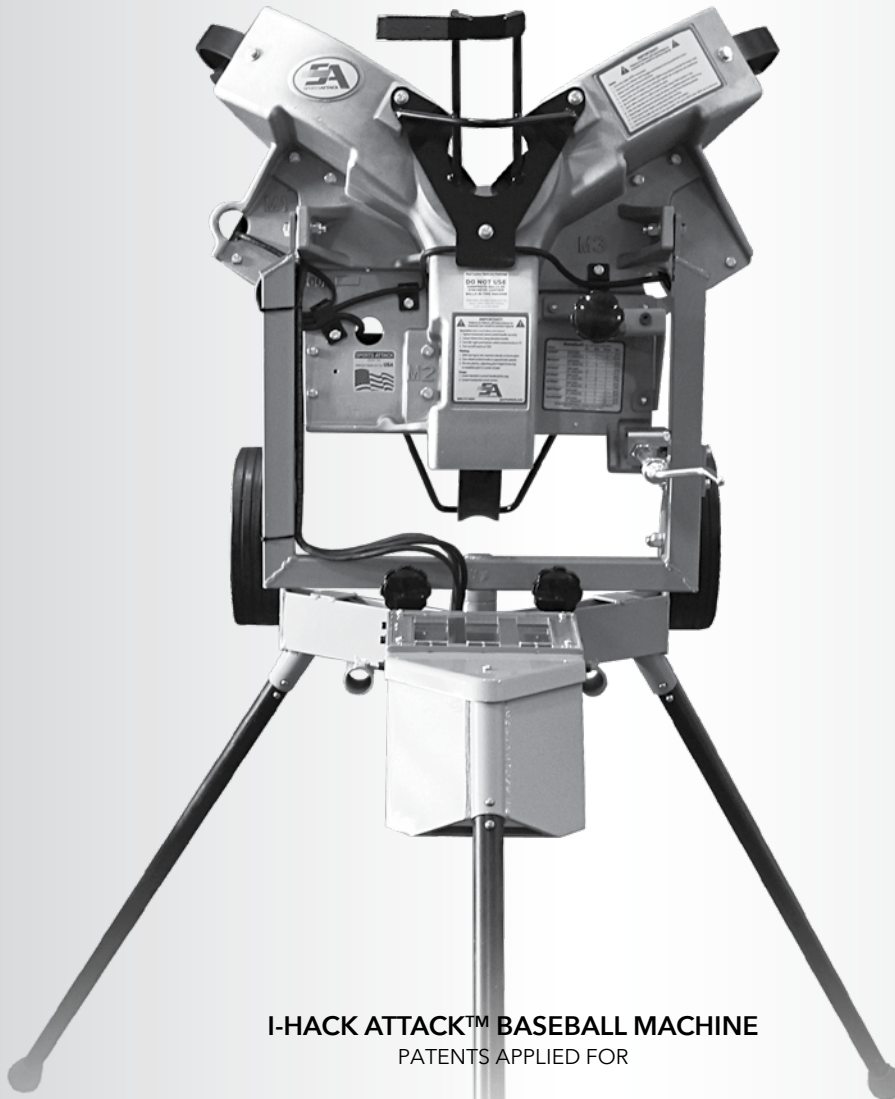

BASEBALL PITCHING MACHINES



I-HACK ATTACK™ BASEBALL MACHINE  
PATENTS APPLIED FOR

## OPERATION MANUAL

SETUP · USE & CARE · SERVICE



SPORTS ATTACK LLC. | 800.717.4251 | [www.sportsattack.com](http://www.sportsattack.com)

REV081020

BASEBALL

## WARRANTY STATEMENT

What is most important to Sports Attack is that your machine meets your expectations of quality and performance. We stand behind the material and workmanship of our machines for five (5) years from the date of original purchase for institutional and residential use and one (1) year for commercial environments, with the following exceptions:

- Throwing Wheels are warranted for two (2) years;
- Electronic Controller is warranted for two (2) years; and,
- Throwing Wheel Motors are warranted for two (2) years.

This warranty excludes any cosmetic issues or normal wear and tear of the unit, and is not in effect if the machine has been misused, misapplied, improperly assembled, or modified without the express written permission of Sports Attack. In addition, this warranty does not apply to damage in transit, in any accident unrelated to the direct operation of the equipment, or by fire, flood or act of God.

If you encounter any issues during the warranty period, Sports Attack will quickly get your machine back in working order. If the warranty repair involves a replacement part, we will make sure you get both the part and easy instructions for replacement at no cost to you. If a service person is needed, Sports Attack will pay the pre-approved labor charge to get your machine back in working order.

Please know that any problem can quickly be resolved with a phone call to our experienced, responsive customer service department at 800.717.4251. We are here to answer your questions and to make sure your machine provides you years of service.

## RETURNS

Sports Attack manufactures the highest quality sports training equipment in the world. If for any reason you are not satisfied, a machine can be returned within 30 days of receipt for any reason for a full refund less a 10% restocking fee. Cost of shipping the unit back to Sports Attack will also be the responsibility of the purchaser. Please note that the refund amount may be reduced by any non-cosmetic damage to the machine.

*If you have any questions or concerns, please give our experienced, responsive customer service department a call at 800.717.4251.*

## SHIPPING DAMAGE CLAIMS PROCEDURE

NOTE: For your protection, please note that equipment in this shipment was carefully inspected and packaged by skilled personnel before leaving the factory.

Upon acceptance of this shipment, the transportation company assumes full responsibility for its safe delivery.

### IF SHIPMENT ARRIVES DAMAGED:

1. **VISIBLE LOSS OR DAMAGE:** Be certain that any visible loss or damage is noted on the freight bill or express receipt, and that the note of loss or damage is signed by the delivery person.
2. **FILE CLAIM FOR DAMAGE IMMEDIATELY:** Regardless of the extent of the damage.
3. **CONCEALED LOSS OR DAMAGE:** If damage is unnoticed until the merchandise is unpacked, notify the transportation company or carrier immediately, and file "CONCEALED DAMAGE" claim with them. This must be done within fifteen (15) days from the date the delivery was made to you. Be sure to retain the container for inspection.

Sports Attack, LLC. cannot assume liability for damage or loss incurred in transit. We will, however, at your request, supply you with the necessary documents to support your claim.

To register the Warranty,  
please go to our website:  
[sportsattack.com/warranty](http://sportsattack.com/warranty)

**For repairs and service after  
the Warranty period, please  
call:**

Sports Attack  
Customer Service Dept.  
**Ph 800.717.4251**  
**Fx 775.345.2883**

## RETURNS

To return an item, please contact our Customer Service Department at 800.717.4251.

A 15% restocking fee will be charged for any items accepted for return. It is the customer's responsibility to handle the repacking and shipment (as well as all associated fees) back to Sports Attack.

No returns will be accepted after 30 days of receiving product.

# TABLE OF CONTENTS

Warranty Statement.....	xi
Safety Instructions.....	2
<b>I-HACK ATTACK BASEBALL MACHINE OPERATION</b>	
Manual Mode.....	5
Change of Speed Mode.....	7
Breaking Ball Function.....	16
Fungo / Defense Function.....	23

## INTRODUCTION

Thank you for purchasing this Sports Attack, LLC. equipment.

Proper assembly, careful operation and consistent maintenance of this equipment will ensure that it gives you the very best performance and a long, economical service life.



# SAFETY INSTRUCTIONS

## ELECTRICAL SAFETY

Use a 115 volt single phase 3-wire (2 wire with ground) grounded power source.

Up to 200 ft. from power source, use a minimum #14/3 grounded 3-wire 15 amp minimum rating extension cord.

Over 200 ft. from power source, consult a licensed electrician for required power cord size.

## OPERATING SAFETY

**CAUTION:** Never reach down near moving throwing wheels for any reason! If it is necessary

to reach into the throwing wheels, **ALWAYS:**

1. Shut down software on home screen (  )
2. Turn on/off switch "OFF".
3. Unplug I-hack Attack from power source
4. Wait until the throwing wheels have come to a complete stop before reaching hands or fingers anywhere near the throwing wheels.

**CAUTION:** Carefully check I-Hack Attack for completeness and condition before connecting to electrical power:

1. Throwing wheels must be tight on the motor shafts
2. Wheel guard and ball chute must be tightly fastened to the throwing head.
3. Carefully check the throwing wheels frequently for cleanliness, chips and cracks. Do not use the machine if the throwing wheels are damaged, or if chips or cracks appear in the wheels. (For damage within warranty period, see Warranty Statement, page xi.)

Do not allow anyone to walk in front of the machine if it is connected to electrical power.

## WARNING PERSONAL INJURY HAZARD

Carefully read all instructions in this manual, and all labels and warnings on I-Hack Attack before using this machine.

Use machine only under adult supervision. Failure to operate I-Hack Attack as described in this manual can result in severe personal injury or death.

•  
Never loosen the horizontal swivel lock while pitching to a batter. If the lock is not secure, the throwing head could pivot.

A loose swivel lock can allow a pitch to be inside which could hit the batter.

## ELECTRICAL SHOCK HAZARD

I-Hack Attack must be connected to a properly grounded electrical receptacle.

•  
Do not operate on wet ground.

## CAUTION PERSONAL INJURY HAZARD

Keep hands away from throwing wheels anytime the machine is connected to a power source.

•  
Carefully check I-Hack Attack for completeness and condition before connecting to electrical power.

## SAFETY INSTRUCTIONS (cont'd)

### BALL SELECTION

Never mix leather balls with synthetic pitching machine balls.

Be careful not to mix new with old balls or balls from different manufacturers.

Balls must be consistent in type and amount of wear to produce repeatability.

Never use wet balls!

### BATTING PRACTICE

Setting Inside/Outside Pitch Locators

- Flip Pitch Left & Right Inside/Outside Locators into vertical position
- Set Yoke crossbar parallel to top of touch screen frame and tighten (clockwise) both locators to lock position
- Throw a test pitch and adjust rear leg until pitch is in center of plate

**ALWAYS** test and adjust the I-Hack Attack before a batter steps up to the plate:

1. Adjust so that I-Hack Attack throws a ball across the plate.
2. Throw test pitches until required velocity and break are reached.
3. Throw several pitches to verify pitch location repeatability.

Batter and pitching machine operator must wear batting helmets.

Only one person at a time should operate the machine.

Always present the ball to the batter before feeding the ball into the machine.

Operator must stand behind a protective screen to prevent injury from balls off the bat. Screen is not included with I-Hack Attack.

### FIELDING PRACTICE

1. Select fungo on home screen
2. Flip Upper Pitch Locator to the left
3. Turn Elevation Handle counterclockwise to lowest position
4. Turn Left and Right Inside/Outside Pitch Locators to down position
5. Machine is now ready to pivot to throw to any position on field

Never reach up chute to push ball into the throwing wheels.

Keep hands and fingers well away from the throwing wheels.

Be careful to keep all persons away from in front of I-Hack Attack.

### CAUTION PERSONAL INJURY HAZARD

**ALWAYS** use a protective screen to protect the operator from the ball off the bat. (Screen not included with I-Hack Attack.)

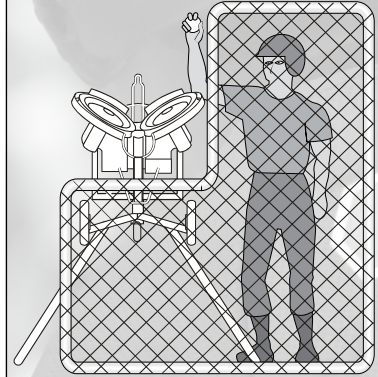

**ALWAYS** wait for all three throwing wheels to come to a complete stop before transporting I-Hack Attack, lifting the throwing head or performing any repairs.

### ADDITIONAL INFORMATION

If you have any questions regarding the safe operation of this equipment, please call:

Sports Attack Customer  
Service Department  
Ph 800-717-4251  
Fx 775-345-2883

# I-HACK ATTACK BASEBALL SOFTWARE OPERATION

Manual Mode . . . . .	5
Change of Speed Mode . . . . .	7
Breaking Ball Function . . . . .	16
Fungo / Defense Function . . . . .	23

## INTRODUCTION

Thank you for purchasing this Sports Attack, LLC. equipment.

Proper assembly, careful operation and consistent maintenance of this equipment will ensure that it gives you the very best performance and a long, economical service life.



# MANUAL MODE

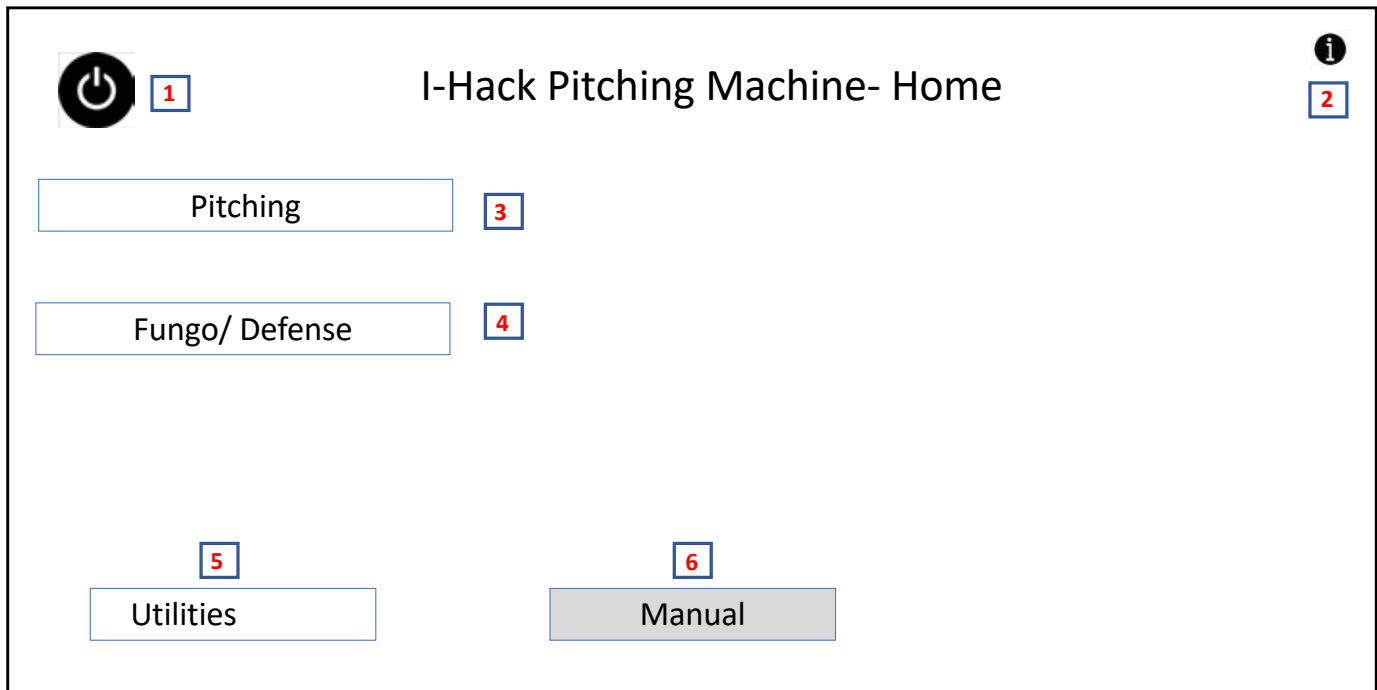

*Home Screen- Selected option will become gray*

1. **Shut down - IMPORTANT!!!** Press to properly shut down the software before turning off the machine
2. **Information-** Press "i" on any screen and make a selection to get information about the selected function
3. **Pitching Option-** Press to select the pitching function
4. **Fungo/Defense Option-** Press to select the fungo/defensive drills function
5. **Utilities-** Press to go to maintenance and settings screens
6. **Manual Mode-** Select to go to manual mode where you establish the setting for each motor/wheel to deliver the desired pitch (similar to dial adjustments on a basic Hack Attack)

# MANUAL MODE - Cont'd

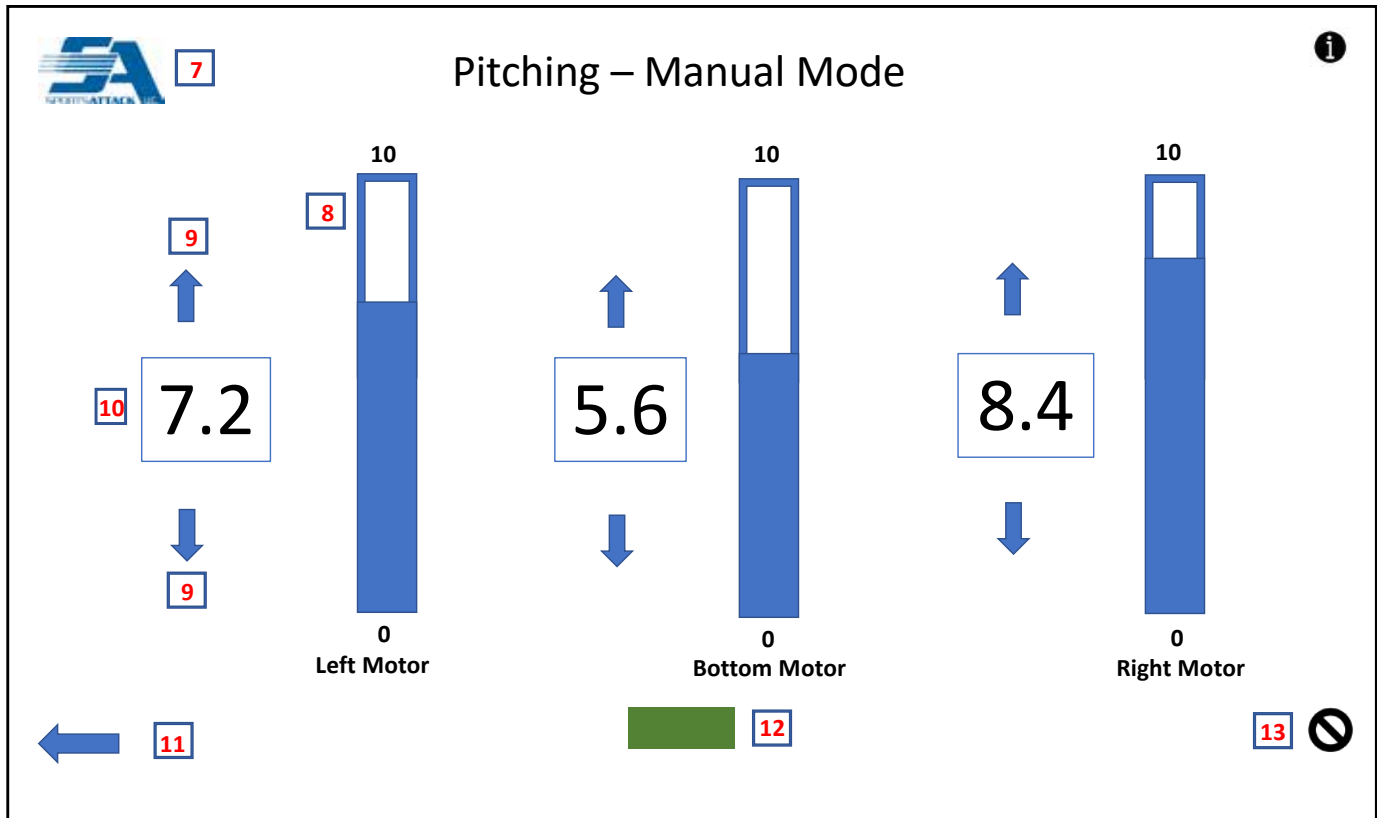

**Note:** On this screen you are able to control each motor individually. Each slider has the corresponding motor effected below it, left motor is on the left, bottom motor in the middle and right motor on the right.

7. **SA Logo-** The SA logo serves as a "home" button, press to return to the initial home screen
8. **Increase or Decrease Slider-** Use slider to make large adjustments. Touch large bar and move up (increase) or down (decrease) to speed/number desired (range is 0 thru 10).
9. **Increase or Decrease Arrows-** Fine tune setting using arrows. Press top arrow to increase speed/number, press bottom arrow to decrease speed/number. Fine adjustments will be made in increments of .2
10. **Selection Read Out-** Your dial setting will be displayed here as the result of the slide bar (large adjustment) and the arrows (fine adjustment). Fine adjustments will be made in increments of .211. Back Screen Arrow- Press arrow to go back to past screen
12. **Ready Indicator-** When machine is ready to throw selected pitch, green "ready" light will be on. If activated, a short sound will also go off.
13. **IMPORTANT!! Emergency Stop-** Press in emergency situations when it is necessary to immediately stop the machine for safety or performance issues.



# CHANGE OF SPEED MODE

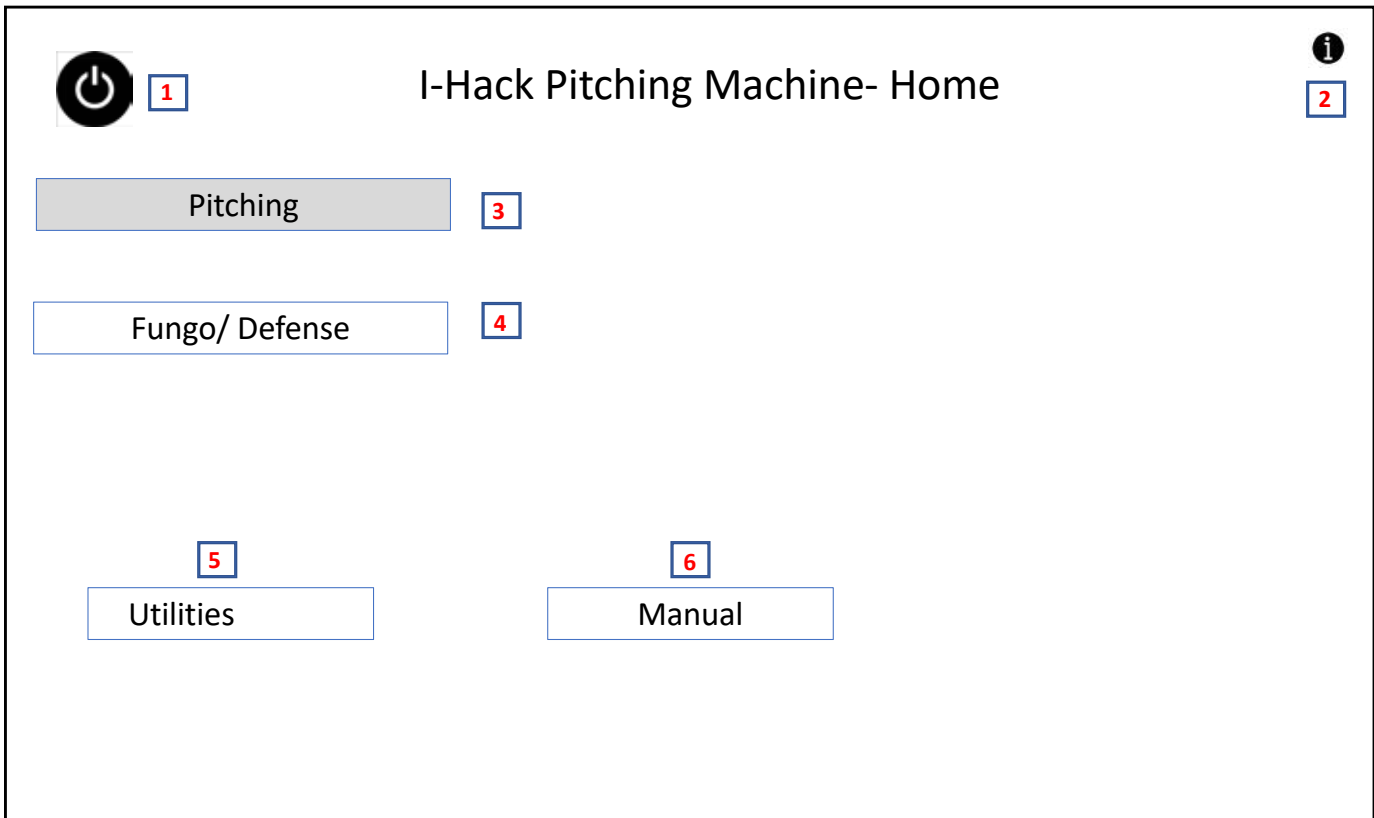

*Home Screen- Selected option will become gray*

1. **Shut down** - IMPORTANT!!! Press to properly shut down the software before turning off the machine
2. **Information**- Press "i" on any screen and make a selection to get information about the selected function
3. **Pitching Option**- Press to select the pitching function
4. **Fungo/Defense Option**- Press to select the fungo/defensive drills function
5. **Utilities**- Press to go to maintenance and settings screens
6. **Manual Mode**- Select to go to manual mode where you establish the setting for each motor/wheel to deliver the desired pitch (similar to dial adjustments on a basic Hack Attack)

## CHANGE OF SPEED MODE - Cont'd

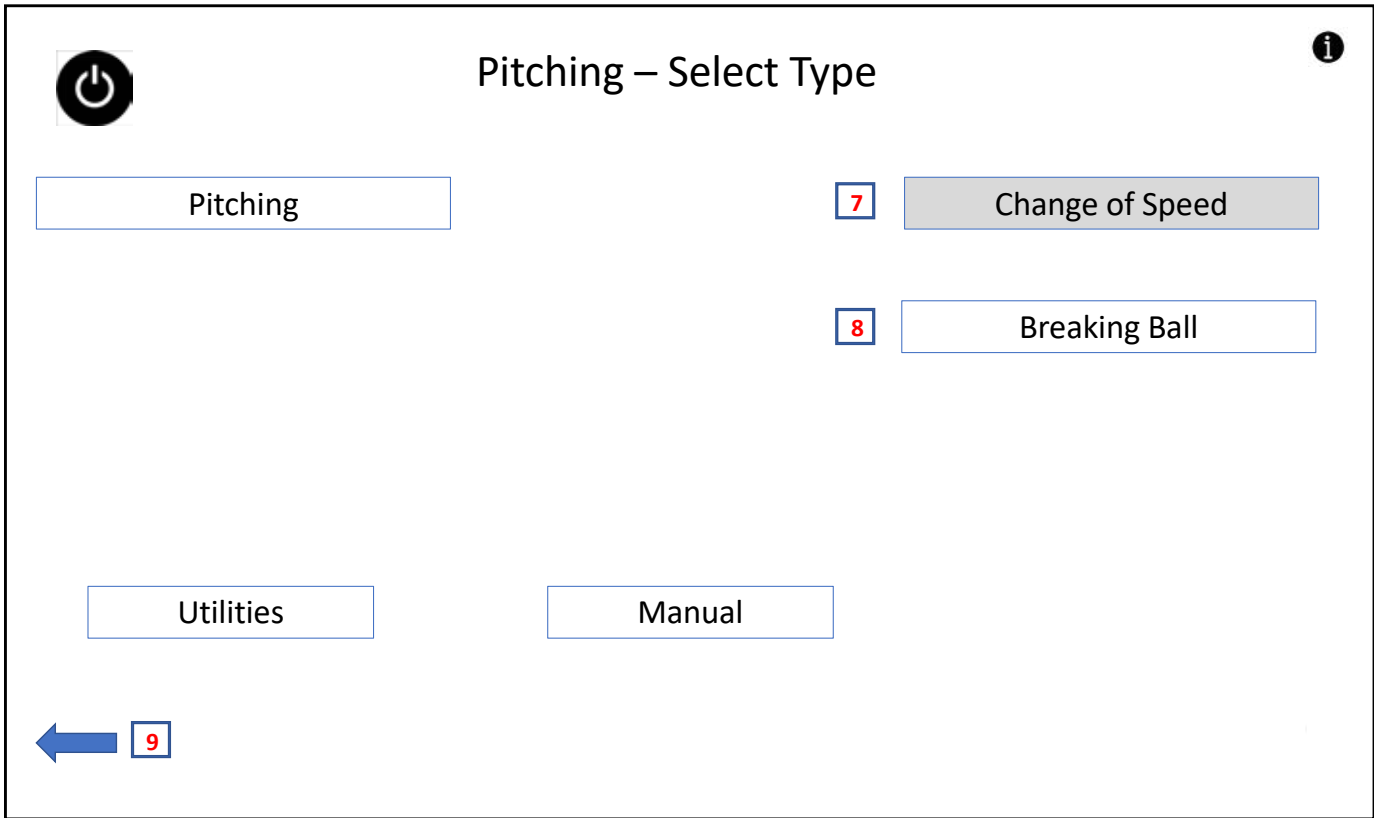

*Type of Pitch Selection Screen*

7. **Change of Speed Pitch Selection-** Press this to select Change of Speed Pitches (fastball, heater, change-up, split-finger)
8. **Breaking Ball Pitch Selection-** Press this to select breaking ball pitches (curveball, slider)
9. **Back Screen Arrow-** Press arrow to go back to past screen

# CHANGE OF SPEED MODE - Cont'd

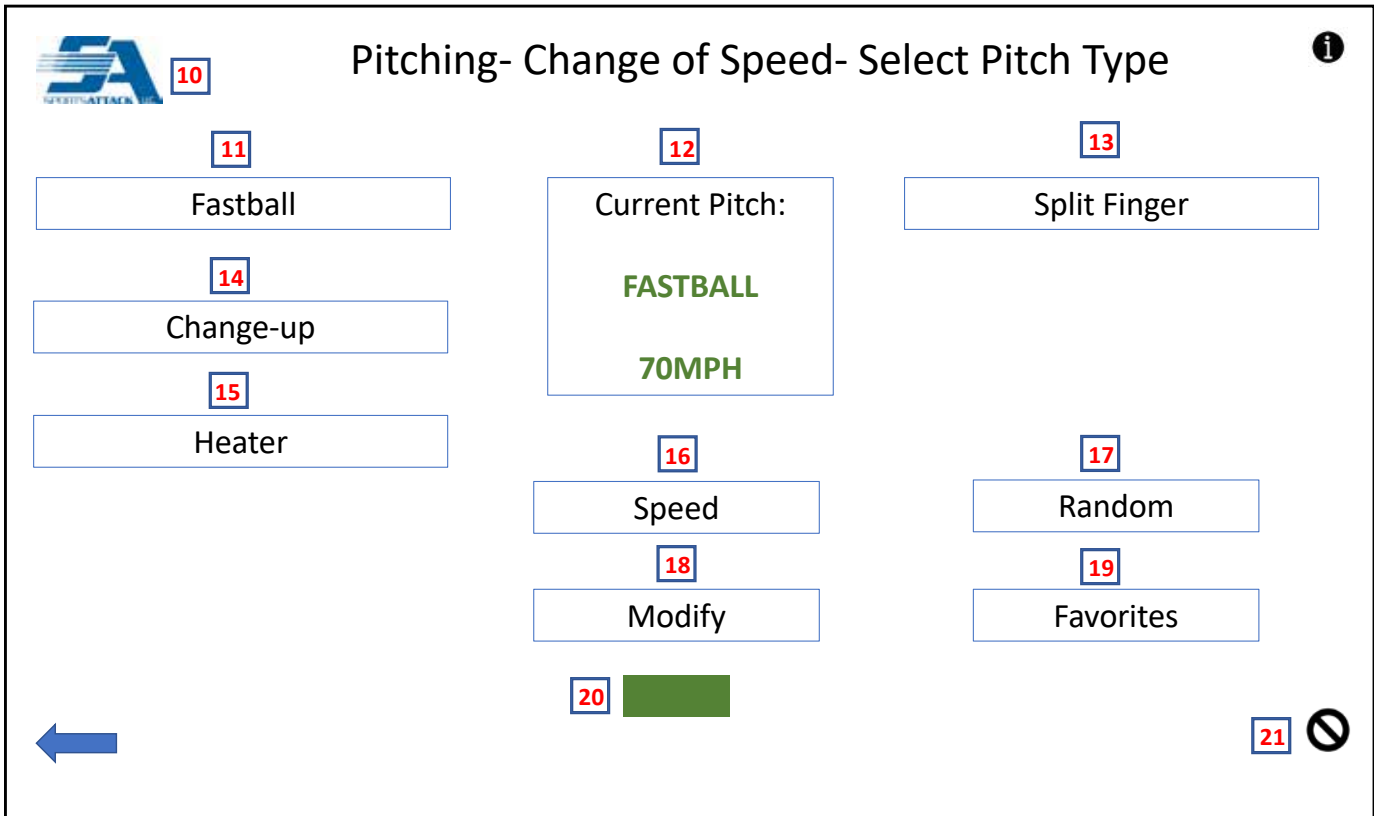

## Pitching, Change of Speed Base Screen

10. **SA Logo**- The SA logo serves as a "home" button, press to return to the initial home screen
11. **Fastball Selection**- Press to select a fastball pitch. A default pitch will be thrown unless you select "speed" or "modify" to alter default pitch
12. **Current Pitch Window**- The pitch that is active (selected) will be presented in this window
13. **Split Finger Selection**- Press to select a split finger pitch. A default pitch will be thrown unless you select "speed" or "modify" to alter default pitch
14. **Change-up Selection**- Press to select a change-up pitch. The pitch will be about 15% slower than the last fastball thrown
15. **Heater Selection**- Press to select a heater pitch. The pitch will be about 5% faster than the last fastball thrown
16. **Seed Adjustment**- Press to alter speed of selected pitch (see next page for details)
17. **Random Pitch Selection**- Will randomly throw fastball, change-up and heater pitches. Will be based on the last fastball thrown. See Random screen for further description.
18. **Modify Adjustment**- Allows an operator to alter each individual wheel/motor to fine-tune the desired pitch. See Modify screen for further description.
19. **Favorites Listing**- Press to go to favorites pages where favorite pitches and sequences are saved
20. **Ready Indicator**- When machine is ready to throw selected pitch, green "ready" light will be on. If activated, a short sound will also go off.
21. **IMPORTANT!!** Emergency Stop- Press in emergency situations when it is necessary to immediately stop the machine for safety or performance issues

## CHANGE OF SPEED MODE - Cont'd

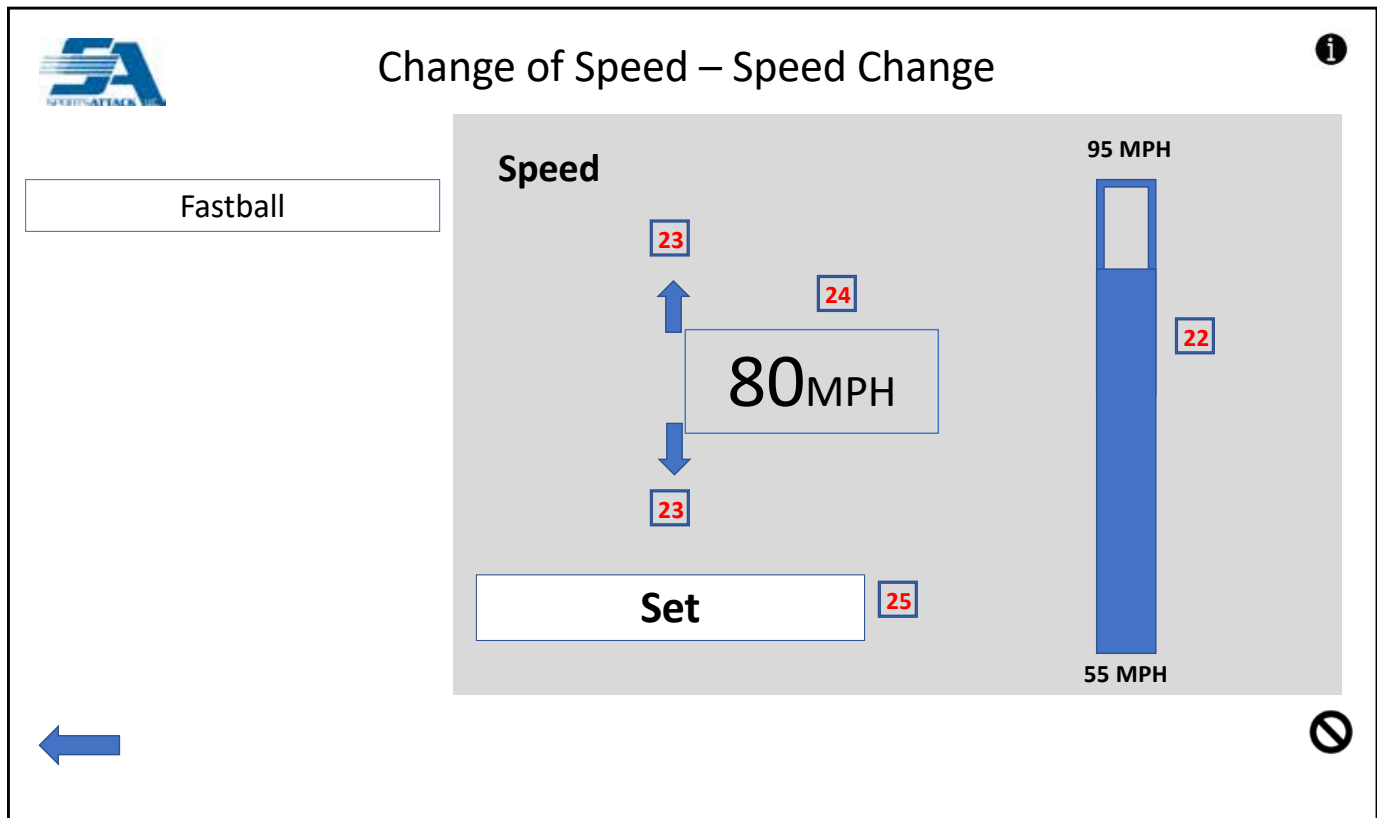

### Speed Change Screen

- 22. **Increase or Decrease Slider-** Use slider to make large adjustments. Touch large bar and move up (increase) or down (decrease) to speed/number desired. Speed range is 55 MPH to 95 MPH.
- 23. **Increase or Decrease Arrows-** Fine tune settings using arrows. Press top arrow to increase speed/number, press bottom arrow to decrease speed/number.
- 24. **Selection Read Out-** Your selected speed setting will be displayed here
- 25 **Set Selection-** Press when desired speed is showing in read-out, you will return to the base pitching screen

## CHANGE OF SPEED MODE - Cont'd

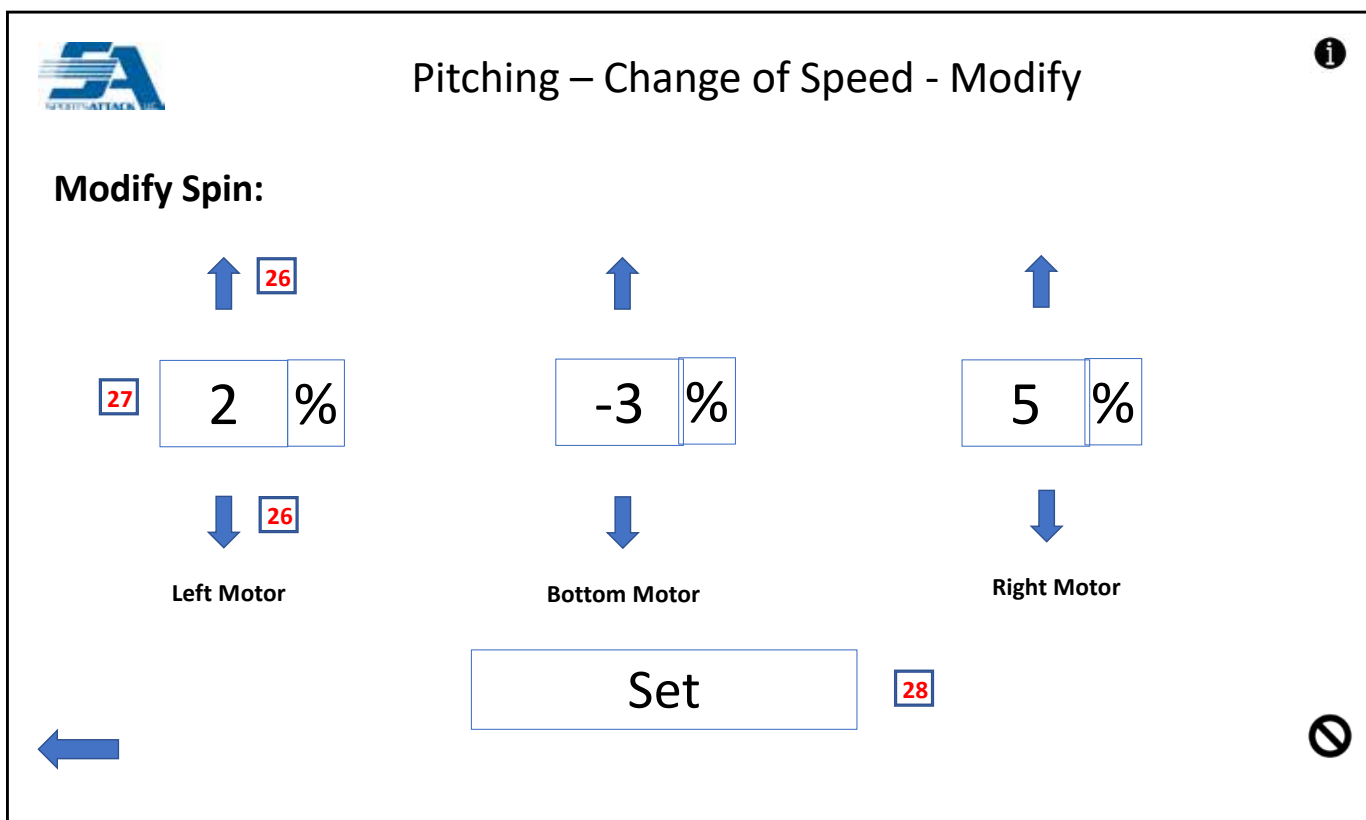

### Modify Screen

On this screen you are able to control each motor individually. Each adjustment has the corresponding motor effected below it, left motor is on the left, bottom motor in the middle and right motor on the right.

- 26. **Increase or Decrease Arrows**- Change settings using arrows. Press top arrow to increase percentage change, press bottom arrow to decrease percentage change. Range of change is from -5% to 10%.
- 27. **Selection Read Out**- Your percentage change selection will be displayed here
- 28. **Set Selection**- Press when desired percentage change is showing in each read-out

# CHANGE OF SPEED MODE - Cont'd

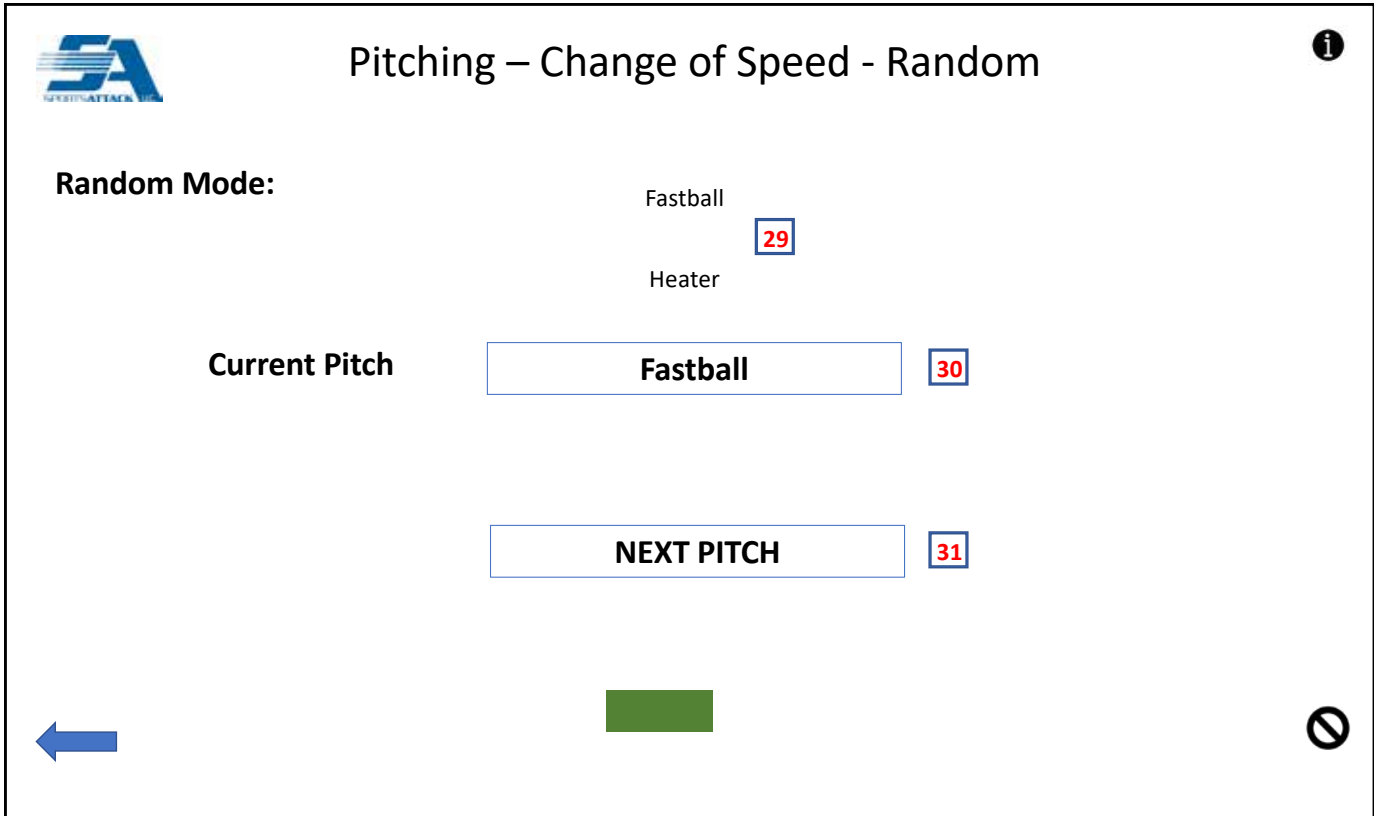

## Random Screen

Screen Note: Random function will randomly throw fastball, change-up and heater pitches. Will be based on the last fastball thrown.

- 29. **Up-Coming Pitches**- The next two pitches are shown so operator knows what pitch to expect
- 30. **Current Pitch Window**- The current pitch that is to be thrown is shown in this window. The machine is ready to pitch when green light is shown
- 31. **Next Pitch**- Press to move forward to the next pitch. Wait until green ready light is on, then feed ball

## CHANGE OF SPEED MODE - Cont'd

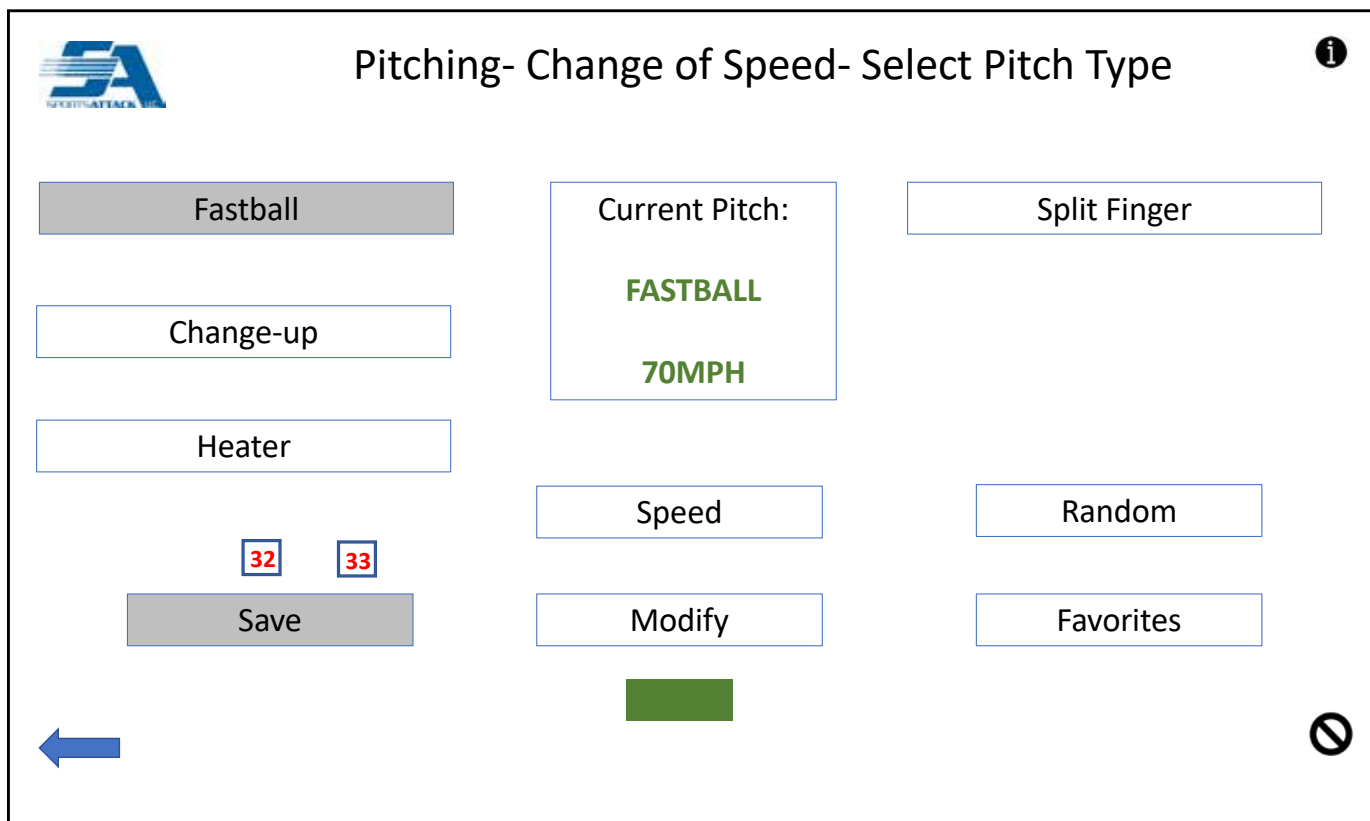

### Save Pitch and Sequence to Favorites

32. **Save Selection-** Select "save" when you have a pitch that you want to save to favorites. How to save a pitch: Select "Save" when you want to save an active pitch to favorites. You will be taken to the favorite pitches page where you will select a location in which to save the pitch (See Favorites page for further description). Pitch will automatically be named based on type and speed of pitch. If you select a location where a pitch is already saved, the new pitch will override the old pitch. There are a total of 18 locations where you can save pitches. (Favorite page one is 1-9, Favorite page two is 10-18)
33. To save a sequence (only for fastball and related change-up and heater pitches), first set up the pitches you want to save in a sequence. Start with the fastball, then select the change-up or heater. If you only want two pitches in the sequence, press save after the two pitches are selected. If you want to add a third pitch (change-up or heater) select it. When you have your sequence established (the last two or three pitches thrown), select save. It will take you to the Favorite Sequences page where you will choose a location in which to save your sequence. Sequence will automatically be saved. It will be named "F,C 80MPH" if you have a fastball (in this example it is an 80MPH fastball) and a change-up saved. If there are three pitches in the sequence, it will be named F C H 75 MPH. This will help you identify your sequences. There are 9 locations for Favorite sequences. See Favorite pages for further description.

## CHANGE OF SPEED MODE - Cont'd

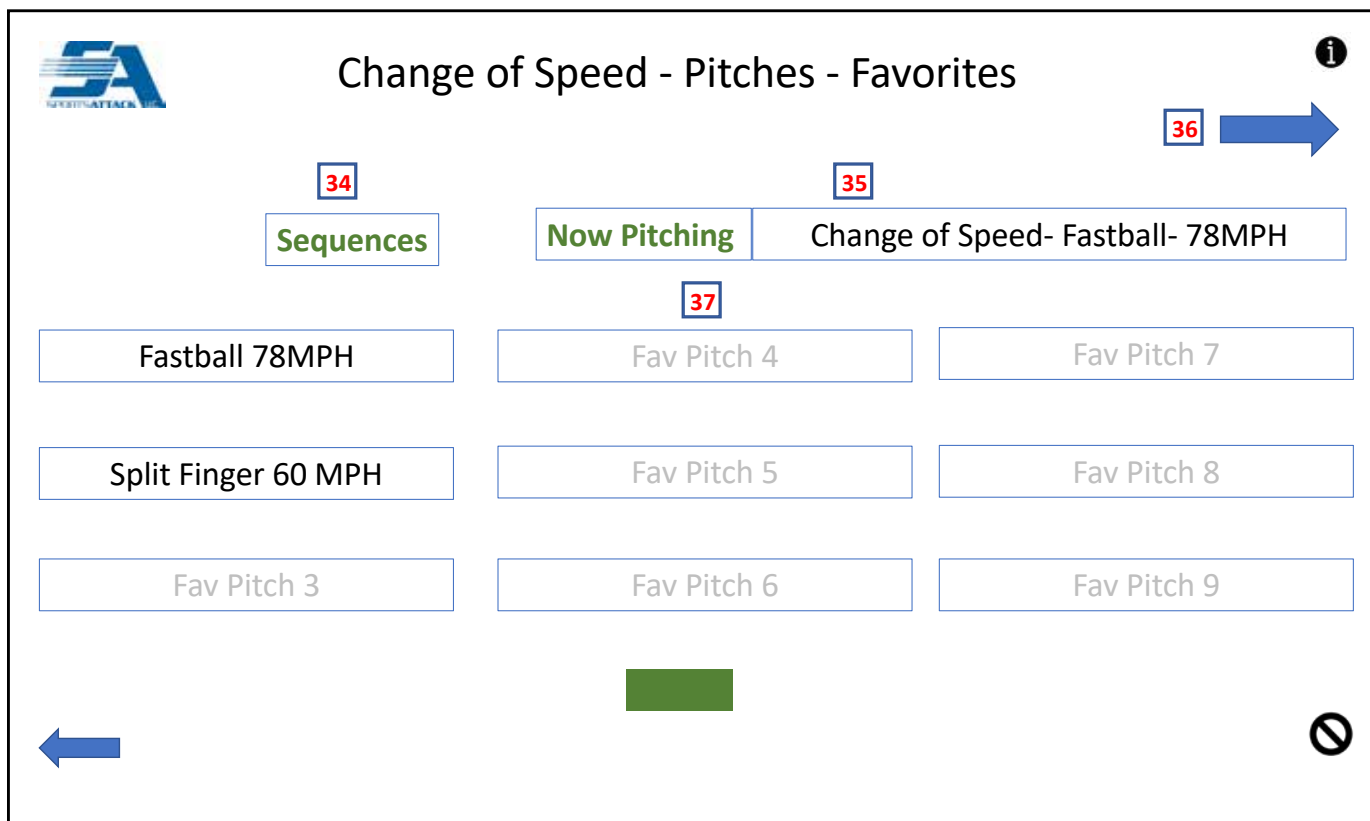

### *Favorite Pitches Screen (Change of Speed)*

34. **Sequences-** When favorites is selected you will automatically go to the favorite pitches screen. Press this to go to the favorite sequences screen.
35. **Now Pitching-** When a favorite pitch is selected and becomes active, it will be detailed here. Select your favorite, wait for the green light and feed ball.
36. **Forward Arrow-** There are two screens of favorite pitches, a total of 18 pitches can be saved. The forward arrow will take you to pitches 10 - 18.
37. **Favorite Pitches-** Saved pitches 1-9 are listed here. Simply select a favorite pitch, wait for the green light and throw the ball. You can throw the pitch again when the light is green or select another pitch.



## CHANGE OF SPEED MODE - Cont'd

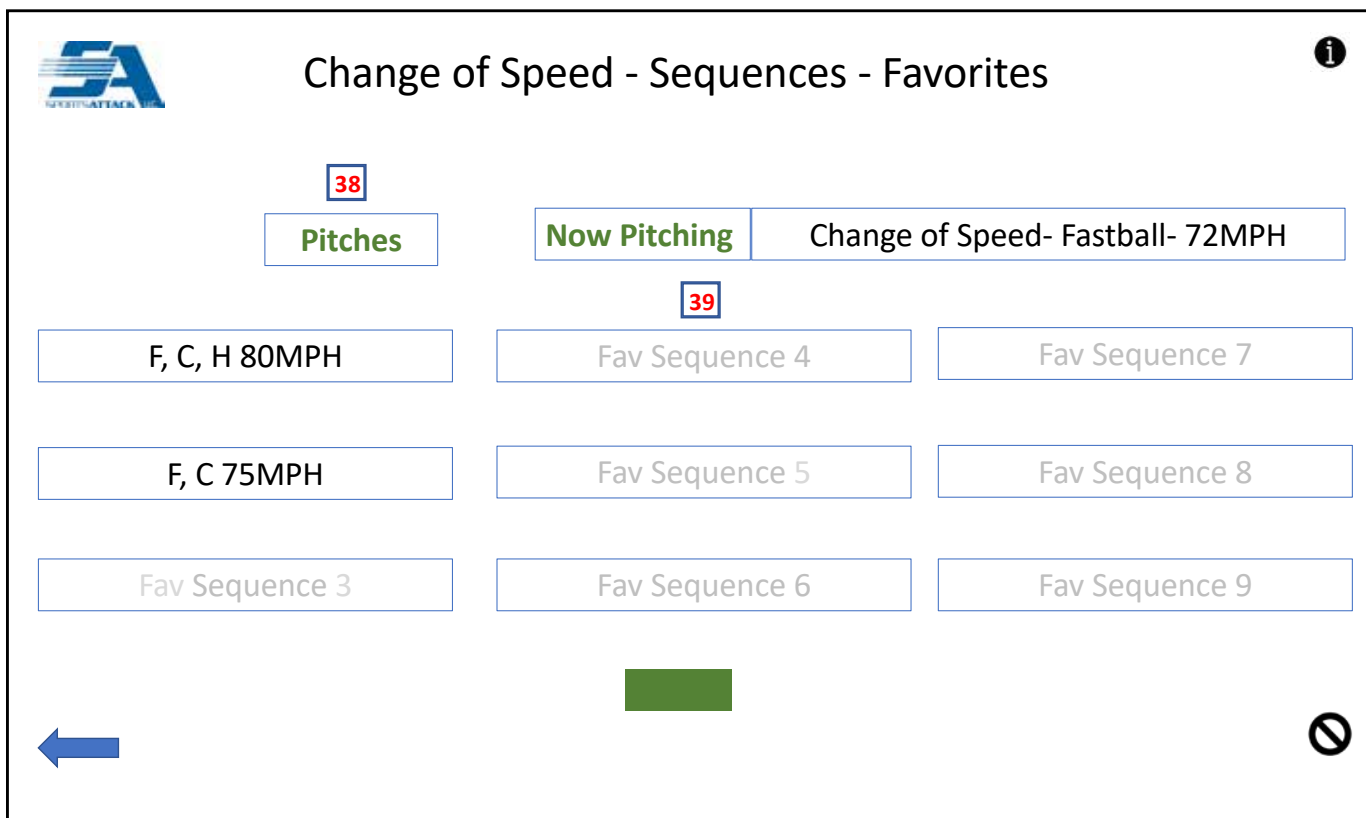

### *Favorite Sequences Screen (Change of Speed Only)*

*Screen Note: Sequence is only available in change of speed mode and with fastball, heater and change-up pitches.*

38. **Pitches**- You are on the favorite sequences screen. Press here to go to page one of favorite pitches 1 - 9
39. **Favorite Sequences**- Nine favorite sequences can be saved. Simply select a favorite sequence, the active pitch will show in the now pitching window. Wait for the green light and feed the ball. The next pitch in the favorite sequence will automatically be the next pitch, wait for the green light and feed ball. There can be two or three pitches saved in a sequence.

# BREAKING BALL FUNCTION

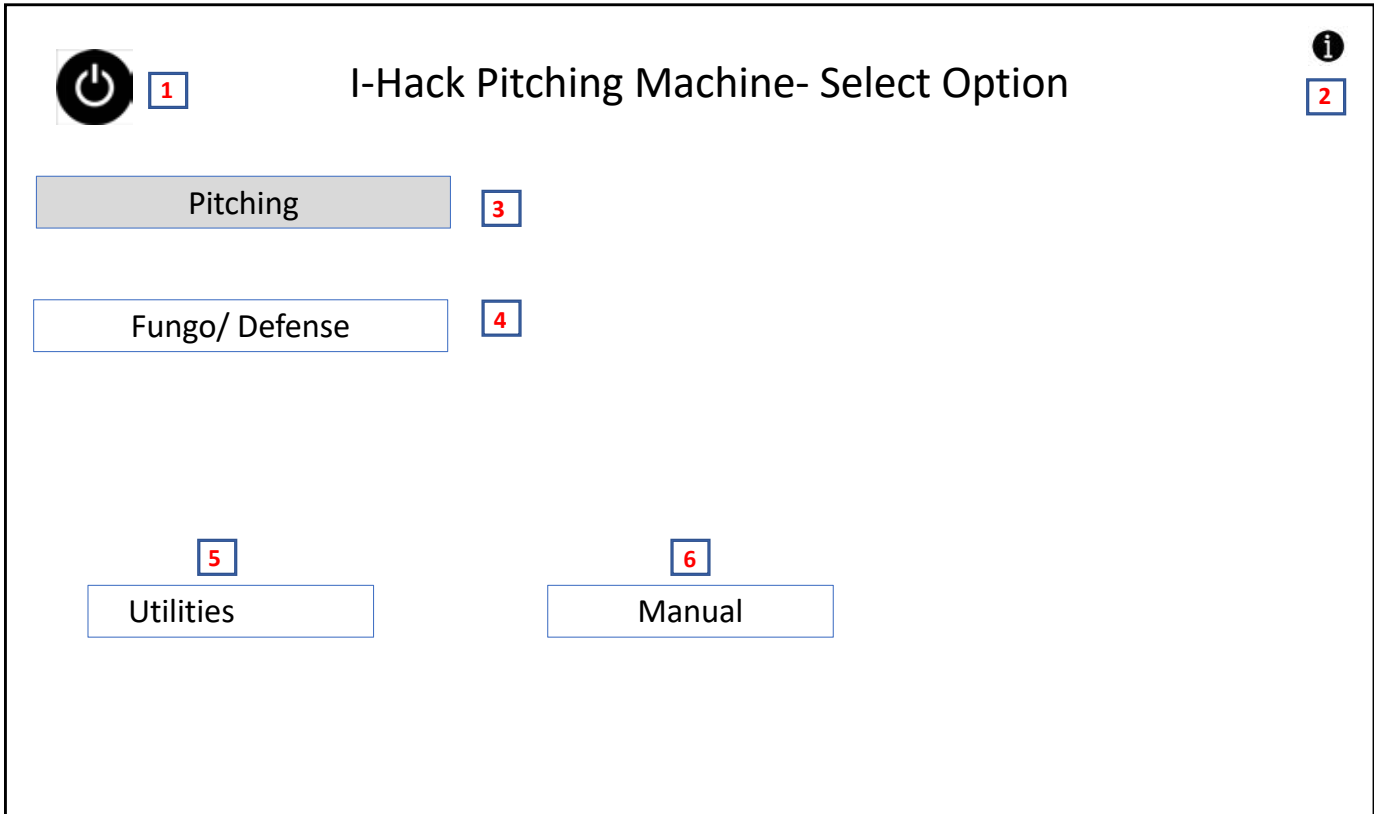

*Home Screen- Selected option will become gray*

1. **Shut down** - IMPORTANT!!! Press to properly shut down the software before turning off the machine
2. **Information**- Press "i" on any screen and make a selection to get information about the selected function
3. **Pitching Option**- Press to select the pitching function
4. **Fungo/Defense Option**- Press to select the fungo/defensive drills function
5. **Utilities**- Press to go to maintenance and settings screens
6. **Manual Mode**- Select to go to manual mode where you establish the setting for each motor/wheel to deliver the desired pitch (similar to dial adjustments on a basic Hack Attack)

## BREAKING BALL FUNCTION - Cont'd

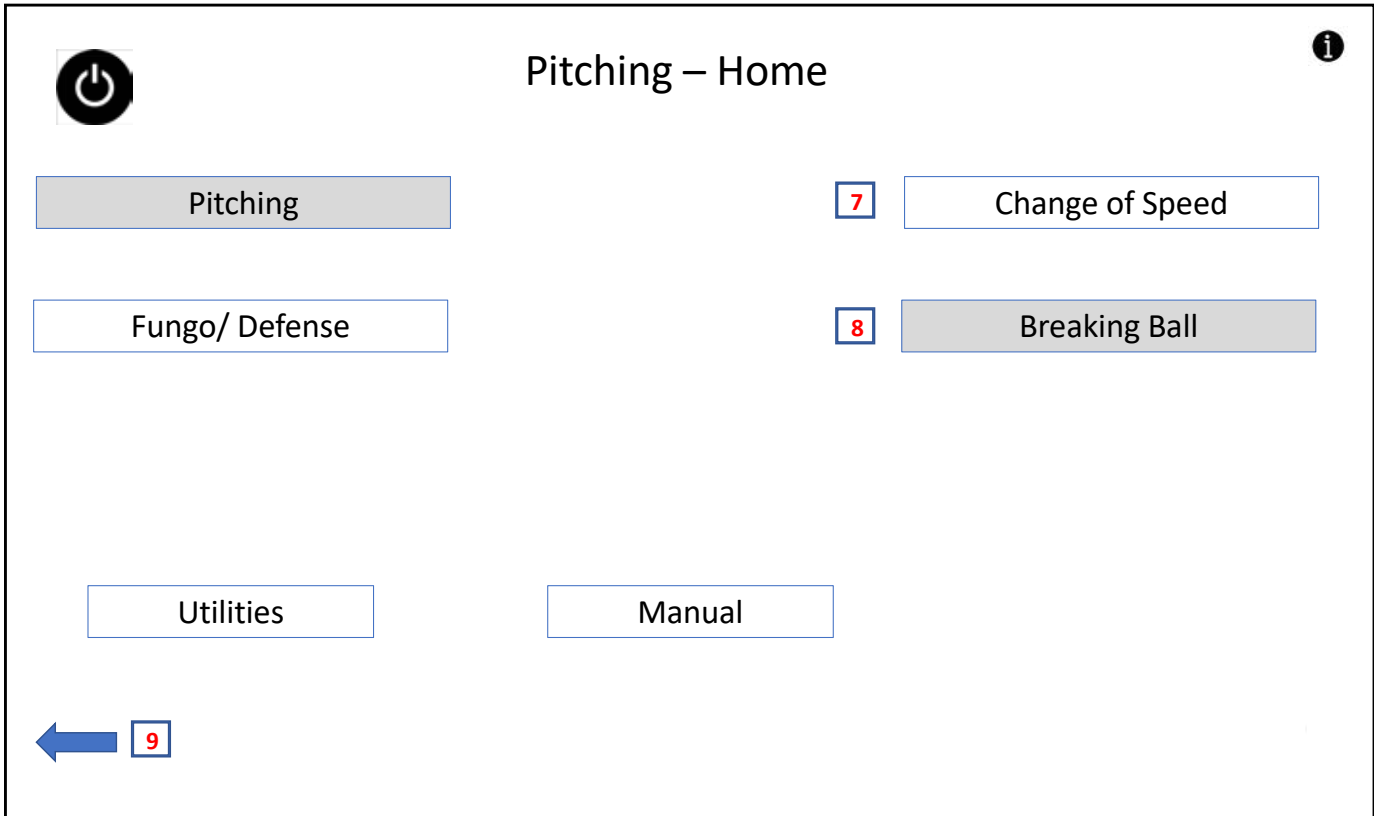

### Type of Pitch Selection Screen

7. **Change of Speed Pitch Selection-** Press this to select Change of Speed Pitches (fastball, heater, change-up, split-finger)
8. **Breaking Ball Pitch Selection-** Press this to select breaking ball pitches (curveball, slider)
9. **Back Screen Arrow-** Press arrow to go back to past screen

## BREAKING BALL FUNCTION - Cont'd

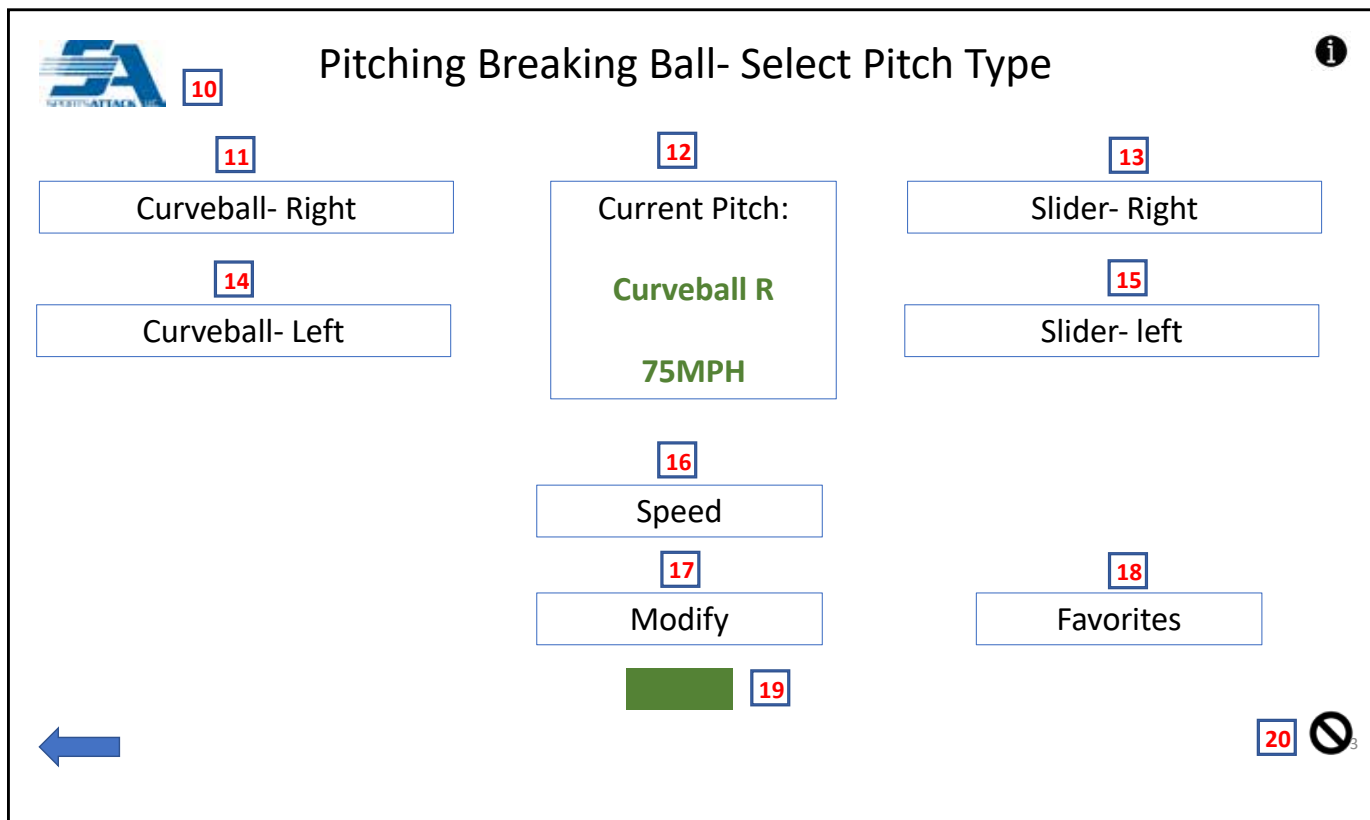

### *Pitching- Breaking Ball Base Screen*

10. **SA Logo**- The SA logo serves as a “home” button, press to return to the initial home screen
11. **Curveball Right Selection**- Press to select a right-handed curveball pitch. A default pitch will be thrown unless you select “speed” or “modify” to alter default pitch
12. **Current Pitch Window**- The pitch that is active (selected) will be presented in this window
13. **Slider Right Selection**- Press to select a right-handed slider pitch. A default pitch will be thrown unless you select “speed” or “modify” to alter default pitch
14. **Curveball-Left Selection**- Press to select a left-handed curveball pitch. A default pitch will be thrown unless you select “speed” or “modify” to alter default pitch
15. **Slider Left Selection**- Press to select a left-handed slider pitch. A default pitch will be thrown unless you select “speed” or “modify” to alter default pitch
16. **Seed Adjustment**- Press to alter speed of selected pitch (see next page for details)
17. **Modify Adjustment**- Allows an operator to alter each individual wheel/motor to fine-tune the desired pitch. See Modify screen for further description.
18. **Favorites Listing**- Press to go to favorites pages where favorite pitches are saved (see Favorites page for further description)
19. **Ready Indicator**- When machine is ready to throw selected pitch, green “ready” light will be on. If activated, a short sound will also go off.
20. **IMPORTANT!! Emergency Stop**- Press in emergency situations when it is necessary to immediately stop the machine for safety or performance issues

## BREAKING BALL FUNCTION - Cont'd

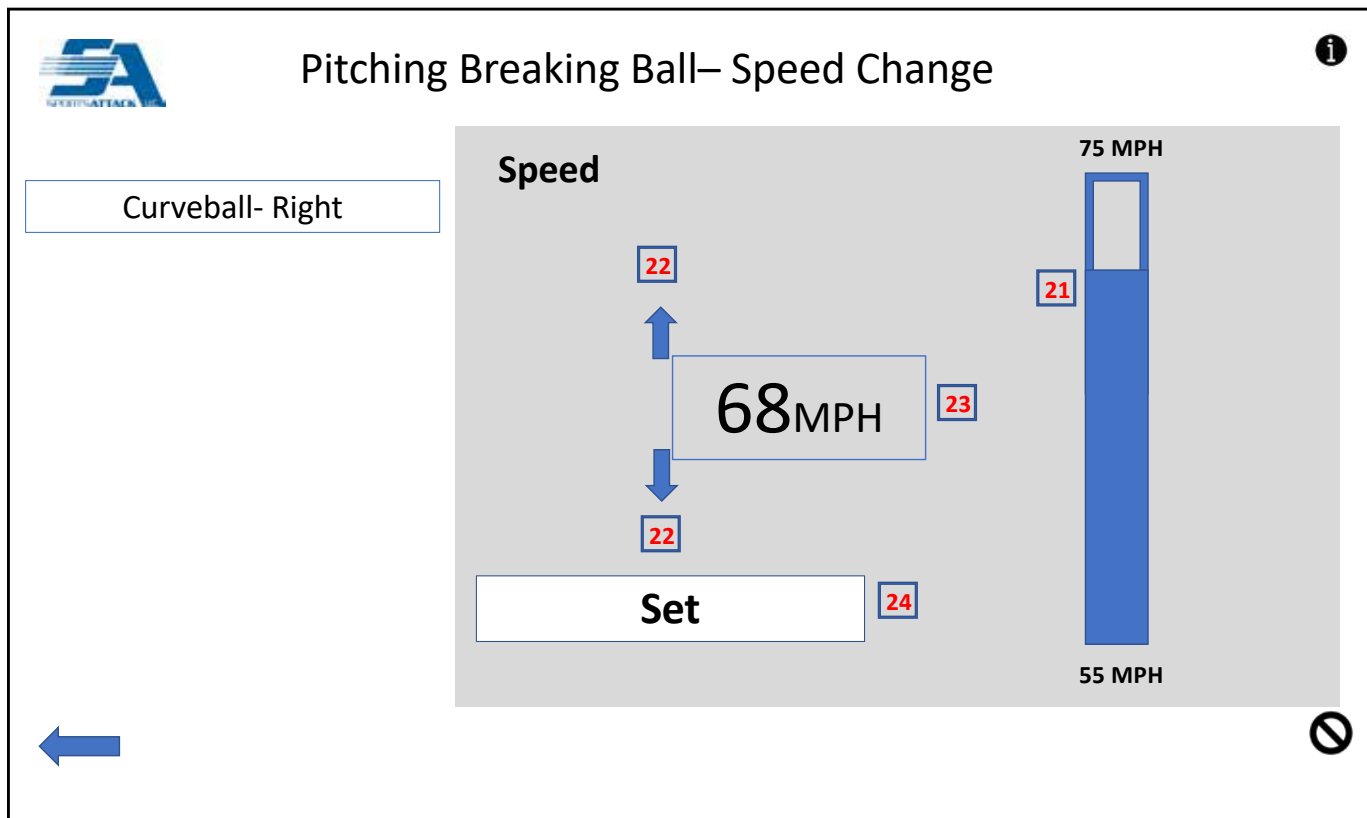

*Speed Change Screen*

21. **Increase or Decrease Slider-** Use slider to make large adjustments. Touch large bar and to move up (increase) or down (decrease) speed/number. Speed range is 55 MPH to 75 MPH.
22. **Increase or Decrease Arrows-** Fine tune settings using arrows. Press top arrow to increase speed/number, press bottom arrow to decrease speed/number
23. **Selection Read Out-** Your selected speed setting will be displayed here
24. **Set -** Press when desired speed is showing in read-out, you will return to the base pitching screen

## BREAKING BALL FUNCTION - Cont'd

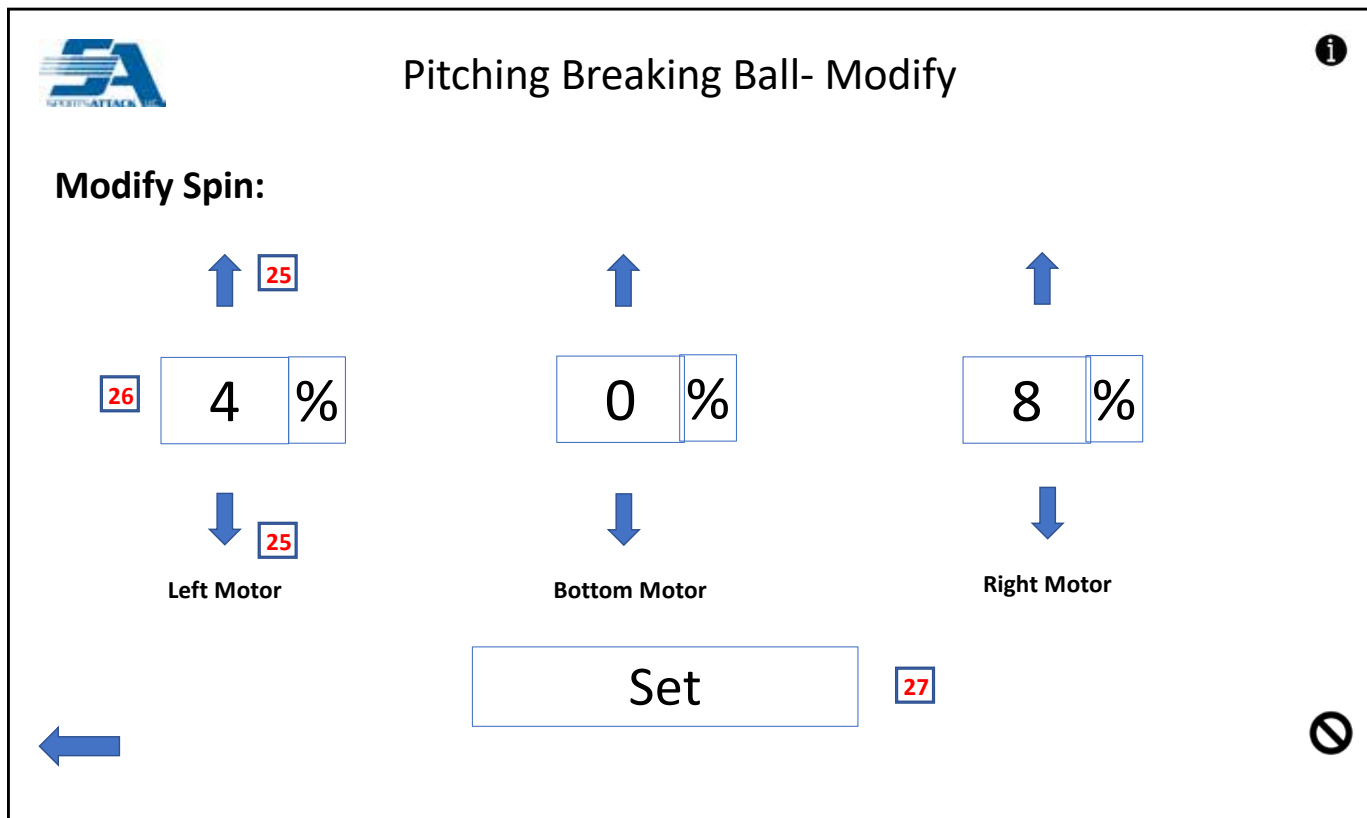

### Modify Screen

On this screen you are able to control each motor individually. Each adjustment has the corresponding motor effected below it, left motor is on the left, bottom motor in the middle and right motor on the right

- 25. **Increase or Decrease Arrows-** Change settings using arrows. Press top arrow to increase percentage change, press bottom arrow to decrease percentage change. Range of change is from -5% to 10%.
- 26. **Selection Read Out-** Your percentage change selection will be displayed here
- 27. **Set Selection-** Press when desired percentage change is showing in each read-out

## BREAKING BALL FUNCTION - Cont'd

The screenshot shows the 'Pitching Breaking Ball- Select Pitch Type' interface. At the top left is the 'SA' logo. The title 'Pitching Breaking Ball- Select Pitch Type' is centered at the top. Below the title are four buttons: 'Curveball- Right', 'Curveball- Left', 'Slider- Right', and 'Slider- left'. In the center, a box displays 'Current Pitch: Curveball R 75MPH'. Below this box are three buttons: 'Speed', 'Modify', and 'Favorites'. The 'Save' button is highlighted with a red box containing the number '28'. A blue arrow points left, and a green bar is visible below the 'Modify' button. An information icon is in the top right corner, and a no-entry icon is in the bottom right corner.

### *Pitching- Breaking Ball - Save Function*

28. **Save Selection-** Select "save" when you have a pitch that you want to save to favorites.

How to save: Select "Save" when you want to save an active pitch to favorites. You will be taken to the favorite pitches page where you will select a location in which to save the pitch (See Favorites page for further description). Pitch will automatically be named based on type and speed of pitch. If you select a location where a pitch is already saved, the new pitch will override the old pitch. There are a total of 18 locations where you can save pitches. (page one is 1-9, page two is 10-18)

# BREAKING BALL FUNCTION - Cont'd

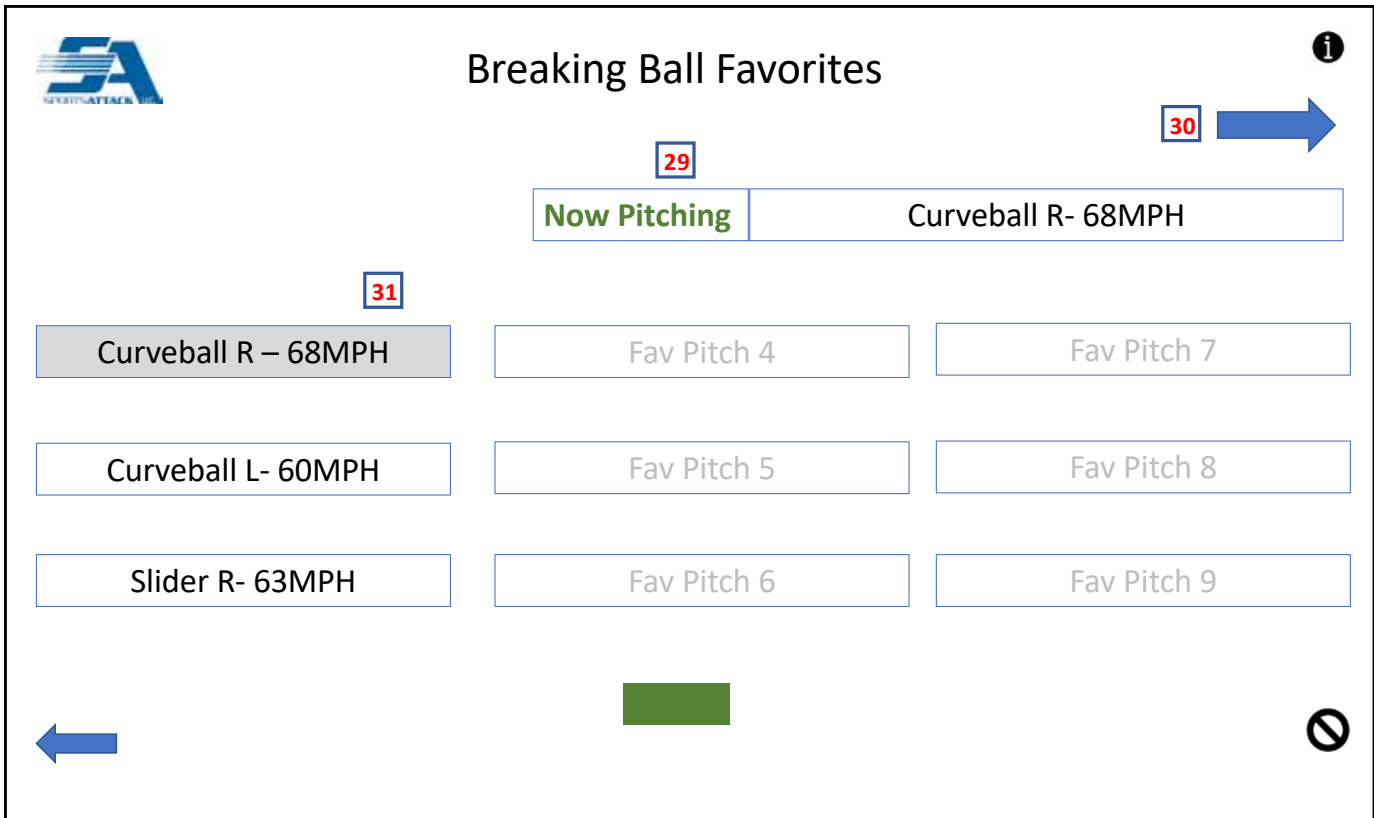

## Favorite Pitches Screen (Breaking Ball)

28. **Now Pitching**- When a favorite pitch is selected and becomes active, it will be detailed here. Select your favorite, wait for the green light and feed ball.
30. **Forward Arrow**- There are two screens of favorite pitches, a total of 18 pitches can be saved. The forward arrow will take you to pitches 10 - 18.
31. **Favorite Pitches**- Saved pitches 1-9 are listed here. Simply select a favorite pitch, wait for the green light and throw the ball. You can throw the pitch again when the light is green or select another favorite pitch. Select the back arrow to return to the Pitching- Breaking Ball Base Screen.



# FUNGO/DEFENSE FUNCTION

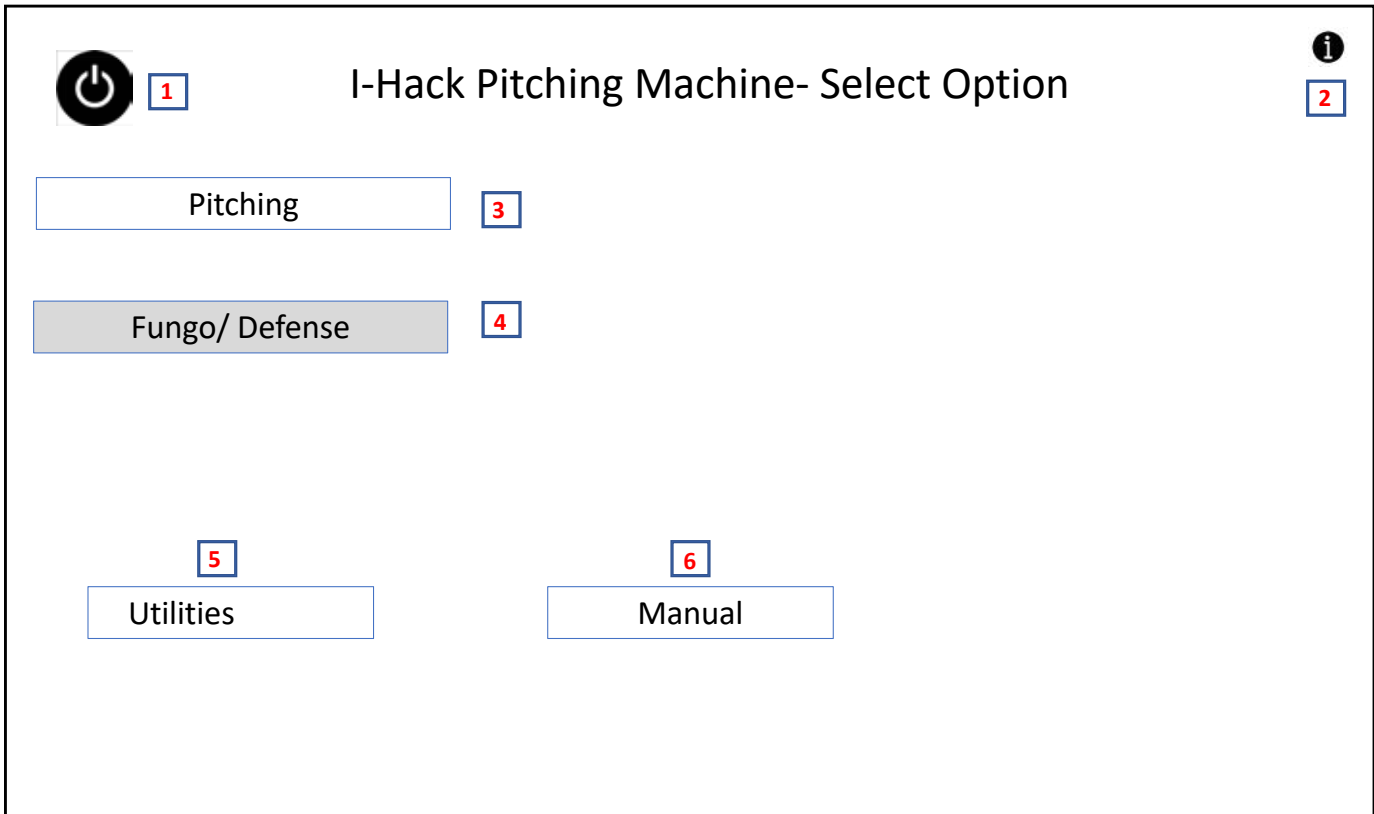

*Home Screen- Selected option will become gray*

1. **Shut down - IMPORTANT!!!** Press to properly shut down the software before turning off the machine
2. **Information-** Press "i" on any screen and make a selection to get information about the selected function
3. **Pitching Option-** Press to select the pitching function
4. **Fungo/Defense Option-** Press to select the fungo/defensive drills function
5. **Utilities-** Press to go to maintenance and settings screens
6. **Manual Mode-** Select to go to manual mode where you establish the setting for each motor/wheel to deliver the desired pitch (similar to dial adjustments on a basic Hack Attack)

## FUNGO/DEFENSE FUNCTION - Cont'd

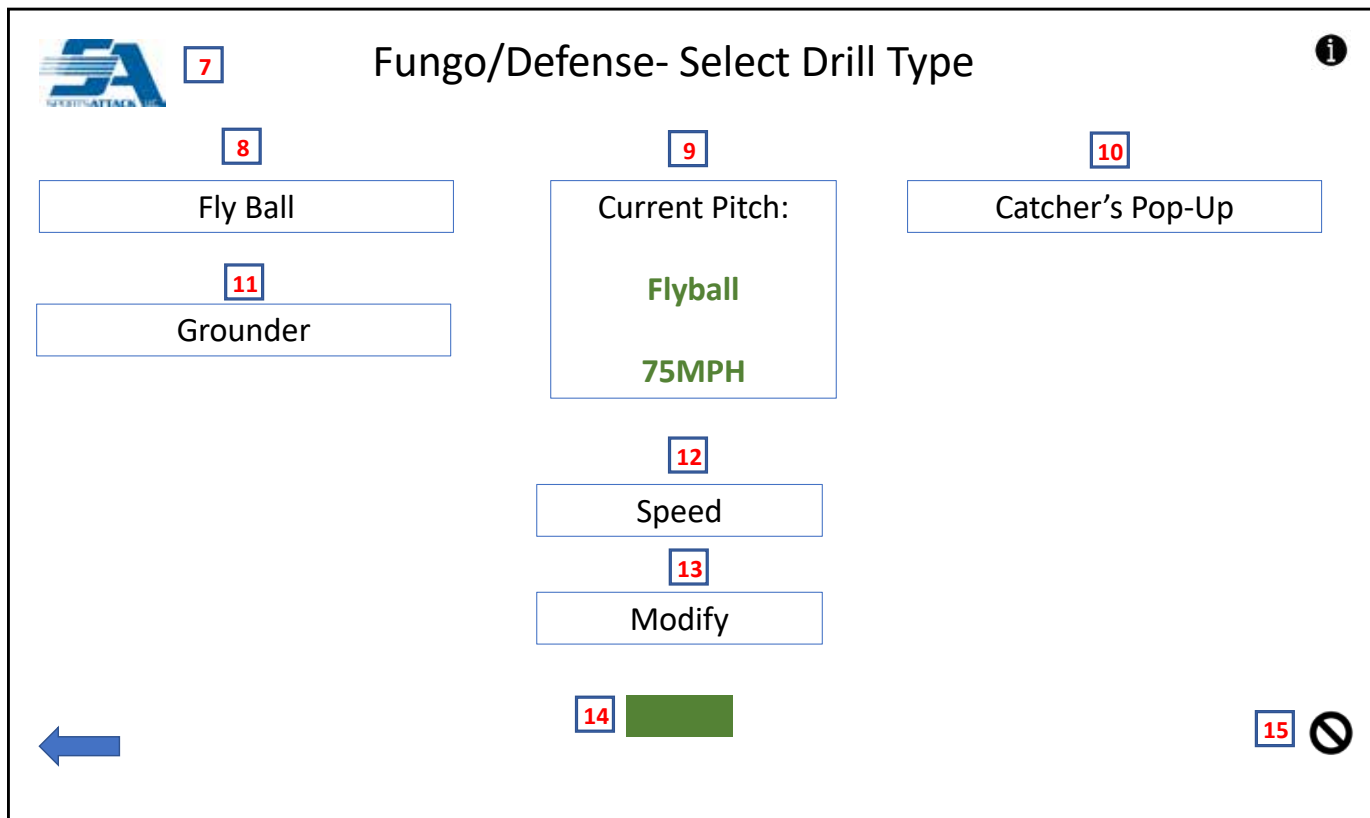

### Fungo/Defensive Drills Base Screen

7. **SA Logo**- The SA logo serves as a “home” button, press to return to the initial home screen
8. **Fly Ball Selection**- Press to select fly ball. Be sure to make necessary adjustments to throwing head to replicate this ball delivery.
9. **Current Pitch Window**- The ball delivery that is active (selected) will be presented in this window
10. **Catcher's Pop-Up Selection**- Press to select catcher's pop-up. Be sure to make necessary adjustments to throwing head to replicate this ball delivery.
11. **Grounder Selection**- Press to select grounder. Be sure to make necessary adjustments to throwing head to replicate this ball delivery.
12. **Seed Adjustment**- Press to alter speed of selected ball delivery (see next page for details)
13. **Modify Adjustment**- Allows an operator to alter each individual wheel/motor to fine-tune the desired ball delivery. See Modify screen for further description.
14. **Ready Indicator**- When machine is ready to throw selected pitch, green “ready” light will be on. If active, a short tone will also sound.
15. **IMPORTANT!! Emergency Stop**- Press in emergency situations when it is necessary to immediately stop the machine for safety or performance issues

# FUNGO/DEFENSE FUNCTION - Cont'd

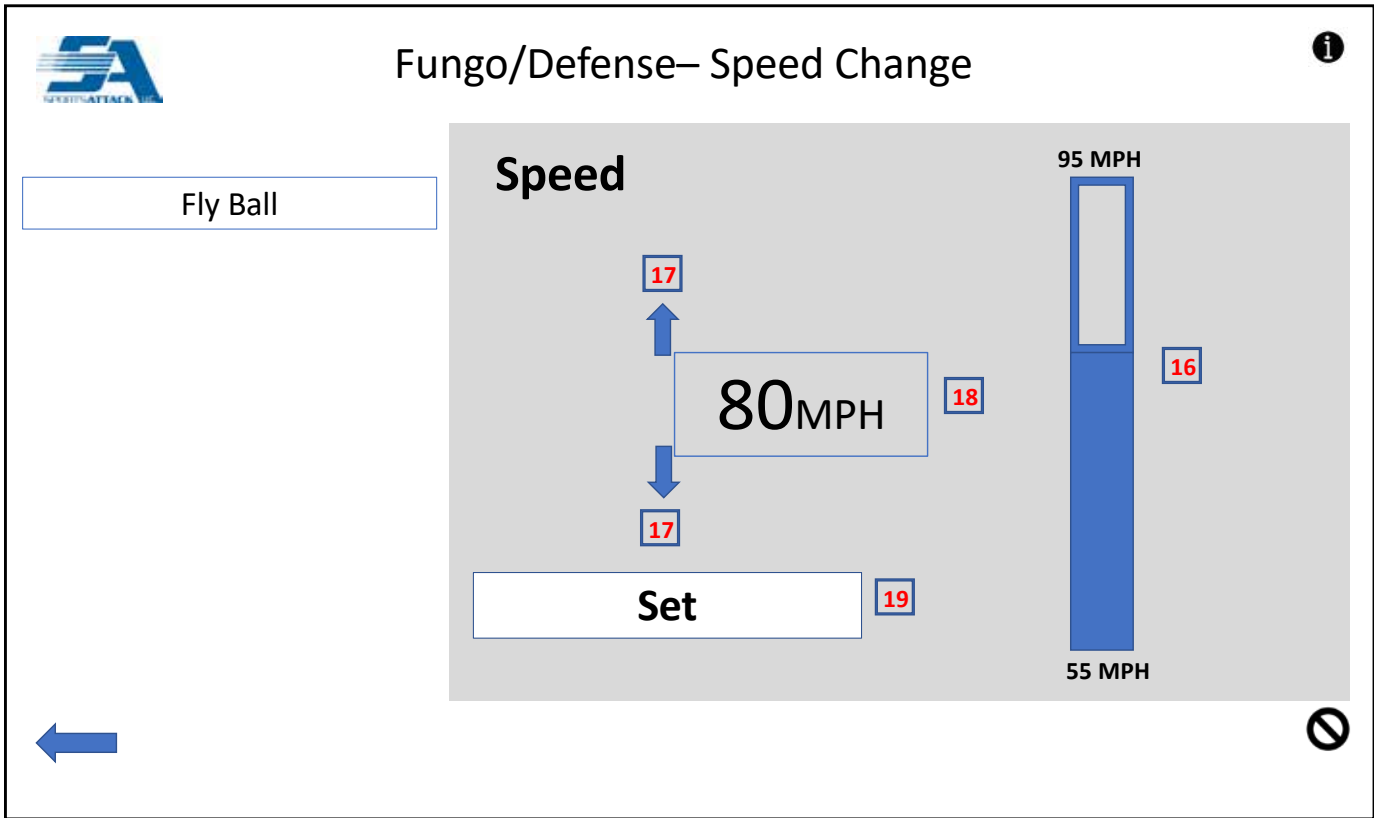

## Speed Adjustment Screen

16. **Increase or Decrease-** Use slider to make larger adjustments. Touch large bar and move up (increase) or down (decrease) speed/number. Speed range is 55 MPH to 95 MPH.
17. **Increase or Decrease Arrows-** Fine tune settings using arrows. Press top arrow to increase speed/number, press bottom arrow to decrease speed/number.
18. **Selection Read Out-** Your selected speed setting will be displayed here
19. **Set Selection-** Press when desired speed is showing in read-out

# FUNGO/DEFENSE FUNCTION - Cont'd

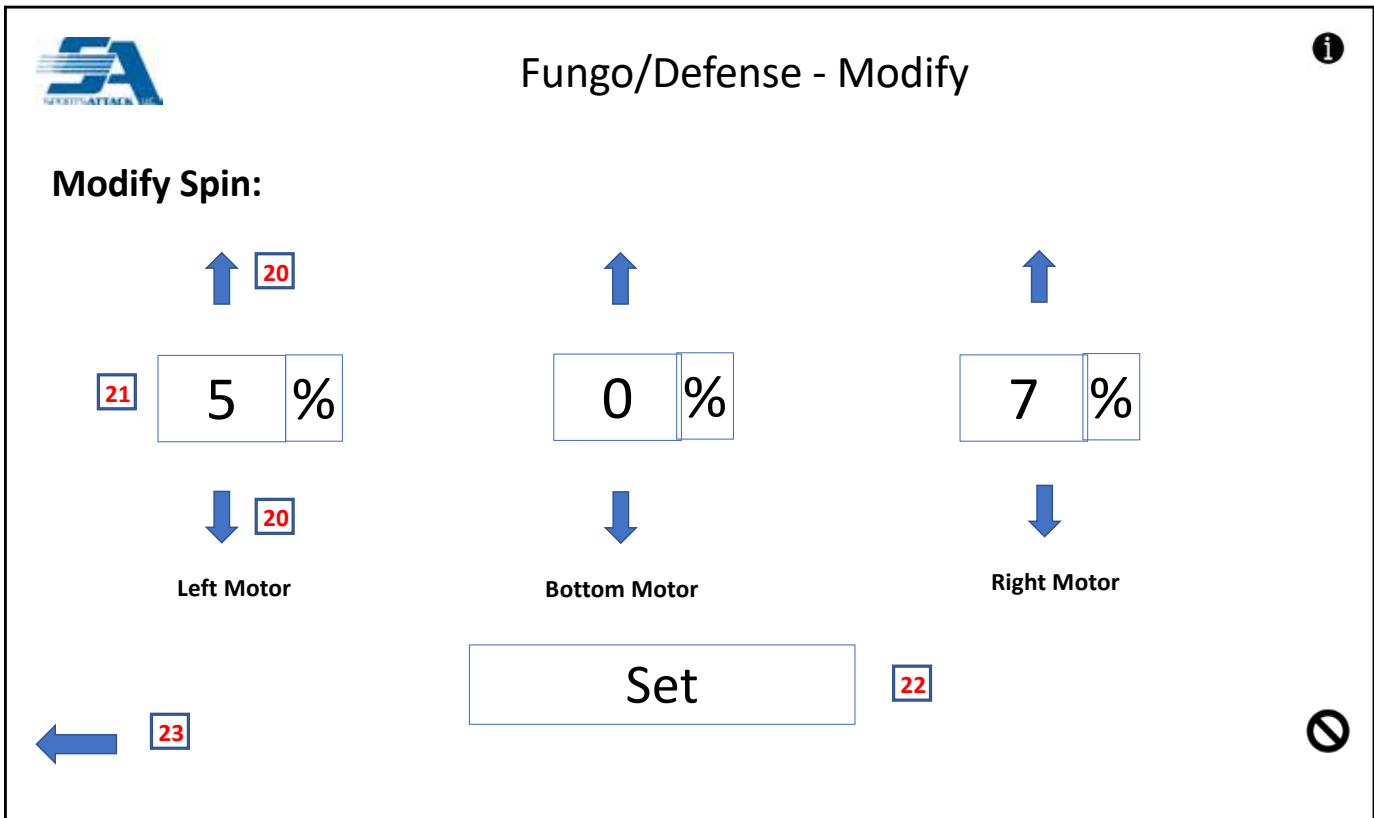

### Modify Screen

On this screen you are able to control each motor individually. Each adjustment has the corresponding motor effected below it, left motor is on the left, bottom motor in the middle and right motor on the right

- 20. **Increase or Decrease Arrows-** Change settings using arrows. Press top arrow to increase percentage change, press bottom arrow to decrease percentage change. Range of modification is -5%to 10%.
- 21. **Selection Read Out-** Your percentage change selection will be displayed here
- 22. **Set Selection-** Press when desired percentage change is showing in each read-out
- 23. **Back Arrow-** Press to move back one screen