

GDF46-18Z/2.2 380V Outline diagram

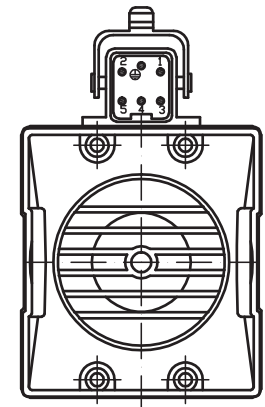
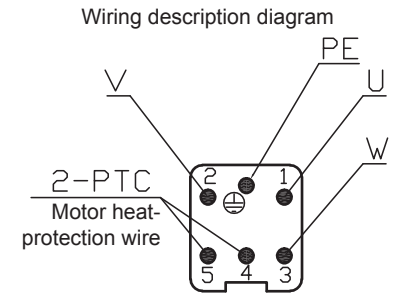
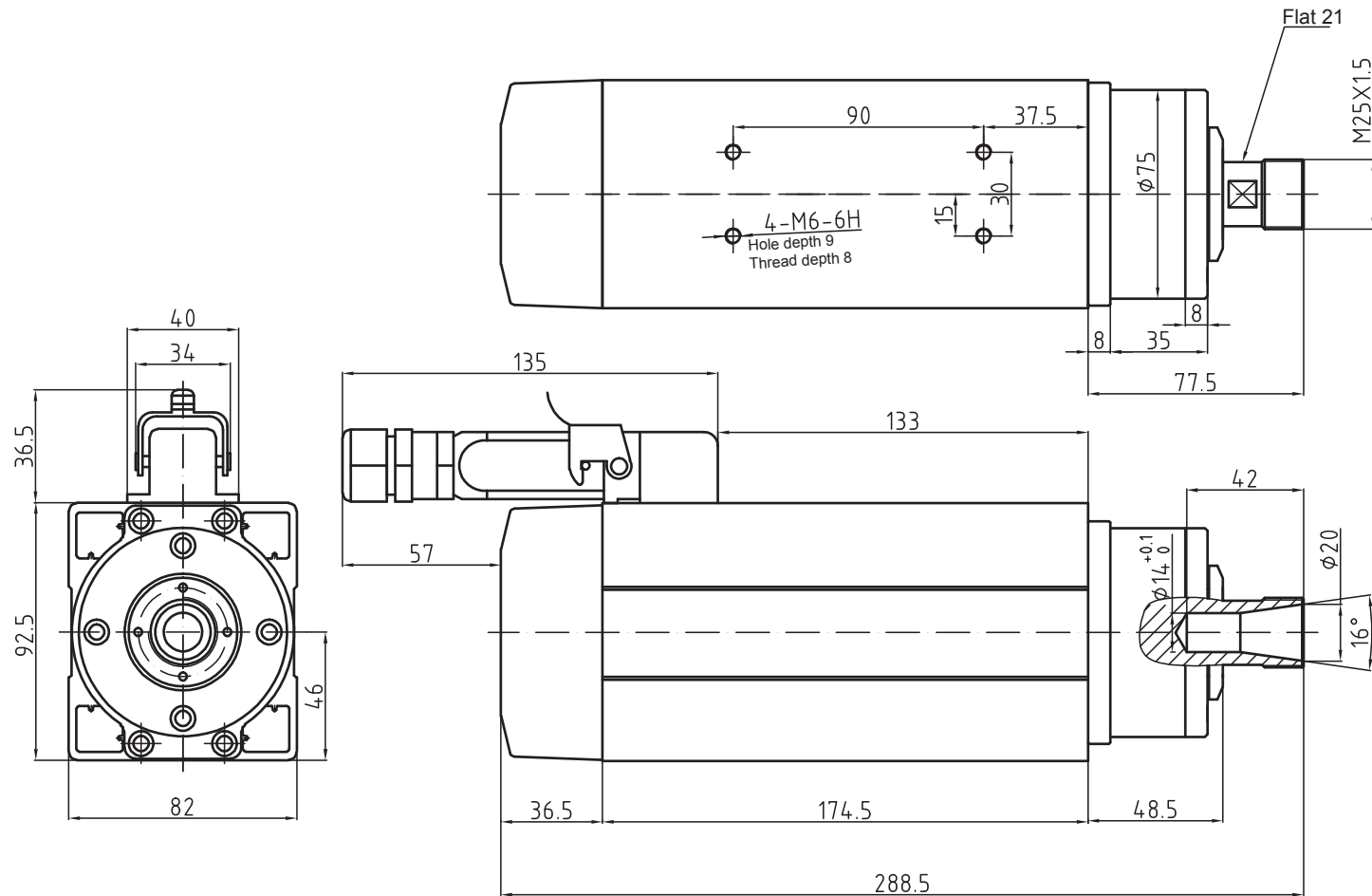

GDF46-18Z/2.2

Power 2.2 kw Weight: 7KG
 Voltage 380 V ER nut: ER20
 Current 4.4 A Cooling method: air cooling
 Frequency 300 Hz Bearing lubrication method: grease lubrication
 Rotating speed 18000 r/min High-precision angular contact ball bearing: 2×7005C P4/1×6002V P5
 Rotating direction: anticlockwise from the shaft extension end

Special attention: thread locking adhesive shall be applied or the spring washer shall be added to prevent the looseness during the installation of the fastening screw!

PTC single-core thermistor parameter	
DC power supply	Maximum DC25V/100mA
-20~25℃	≤100Ω
≤90℃	≤250Ω
105℃	≤550Ω
110℃	Rated operating temperature
115℃	≥1330Ω
≥125℃	≥4KΩ
≤160℃	Maximum storage temperature