

# Charging Station - Installation Manual



# CHARGING STATION INSTALLATION MANUAL

2020-14-09 Fifth Edition

EN

# Content

Wall Box Installation manual.....	1
Smart charge APP manual (old version Charging station before January 15, 2021) .....	1
1. Installation Guide .....	5
Safety first.....	5
1.1 Safety and user information.....	7
1.2 Delivery package / accessory pack.....	9
1.3 Installation requirements .....	10
1.4 Dos and don'ts .....	11
1.5 Installation notes .....	12
1.6 Cleaning and maintenance .....	13
1.7 Introduce .....	14
1.7.1 Product information .....	14
1.7.2 The dimensions.....	15
1.7.3 Drawing .....	16
1.7.4 Mounting plate.....	17
1.7.5 Expansion bolts and screws .....	18
1.7.6 Charging station body.....	19
1.7.7 Charging plug.....	20
1.8 The installation procedure.....	21
1.8.1 Installation tools.....	21
1.8.2 Installation process .....	22
1.8.3 Electrical connection.....	25
1.9 First commissioning.....	26
1.10 Environment.....	30

# 1. Installation Guide

## Safety first

Please observe all following safety and user information:

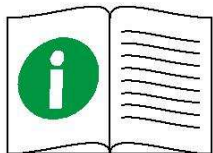

Relevant local regulations for operating electrical devices always apply.



Indicates: Risks arising from damage to the device Risks for other users.

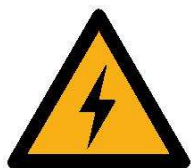

Indicates: Dangerous electrical currents /  
Dangers to life and body parts.



Indicates: important information and particularities.



1. Suitable for garages, carports or outdoor as well as for underground parking garages, apartment blocks, hotel parking lots etc.
2. for wall mounting or freestanding with matching Duostar stainless column,
3. IP class: IP 55(Splash-proof)

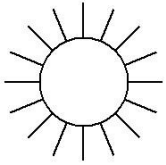

Charging station should not be directly exposed to sunlight.



The installation site must offer protection against rain and running water or other liquids.



Keep away from fire to ensure personal safety.

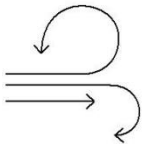

The installation site must offer sufficient space.

We recommend that this product be installed in a place that is rainproof and sun proof, or it can be equipped with protective function. This can reduce the possibility of failure and extend the life of the product. If you need support, please contact your supplier.



## 1.1 Safety and user information



The rated voltage must

be observed.

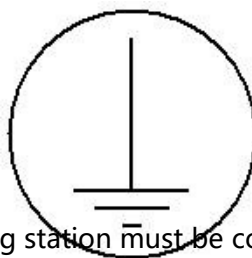

Charging station must be connected

to a protective earth conductor

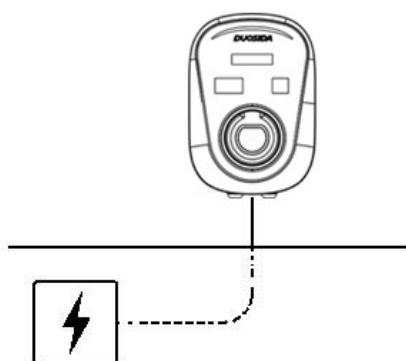

1. Ideally, the installation site should already provide for a connection to the electricity grid.

2. Otherwise, a power supply cable especially.

3. If unsure, please contact your Specialist electrical contractor

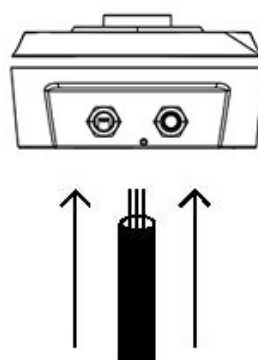

1. Ideally, the cable entry is from the underside of the housing base

2. Above or below surface must be installed

power supply possible.

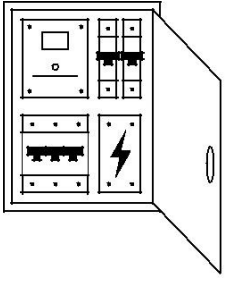

The power supply in the domestic power distribution box must be protected separately by a suitable and accurate dimension miniature circuit breaker (C characteristic)

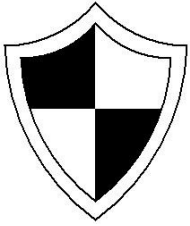

Complies with all technical safety requirements, standards and guidelines.

Represents the current state of technology



DC fault current detection is required by law in many countries

## 1.2 Delivery package / accessory pack

RFID card 3(Optional)

APP function and Installation manual 1

Installation drawing 1



### 1.3 Installation requirements



The installation surface measures at least 262 x 222 mm (height x width).

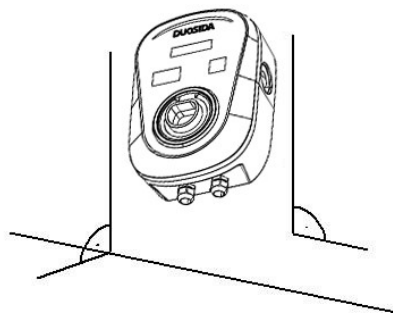

The mounting substrate must be level and firm.

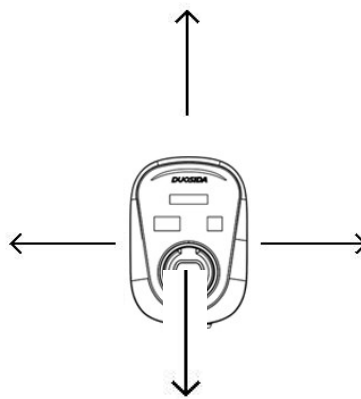

Minimum distances to other technical installations must be observed.



The installation height is between 140 and 160 cm (floor to bottom edge of housing).

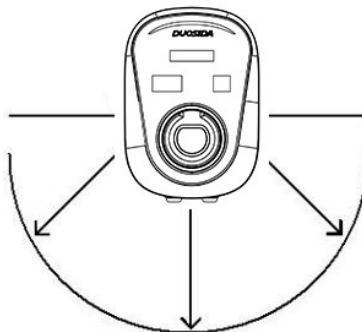

The installation site must be freely accessible.

## 1.4 Dos and don'ts

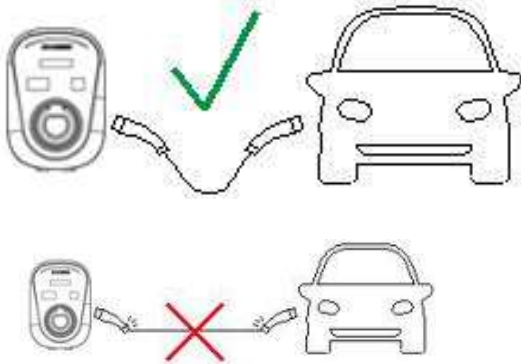

The charging cable must not be under strain, during the charging process.



The charging cable and the charging connector must not be driven over.

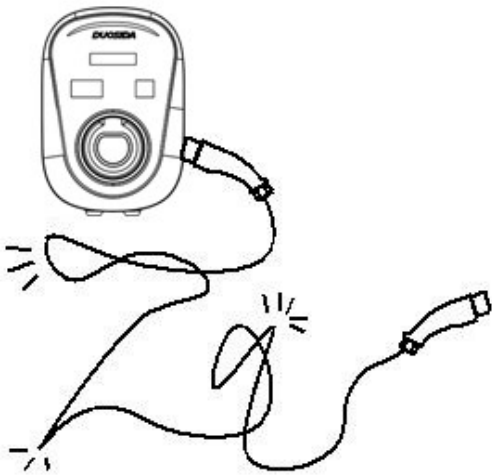

The charging cable must not be coiled, be kinked or twisted

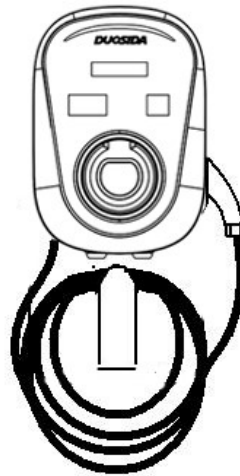

The charging cable must be tightly and stored.

## 1.5 Installation notes

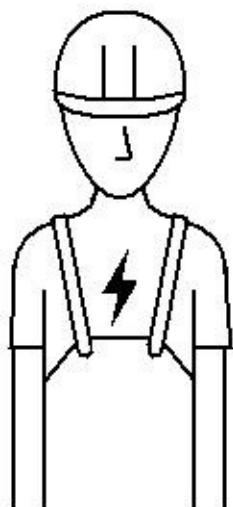

(De-)installation and repairs must only be carried out by a specialist electrical contractor

No modifications must be made to the charging station

None of the components have to be maintained by the user

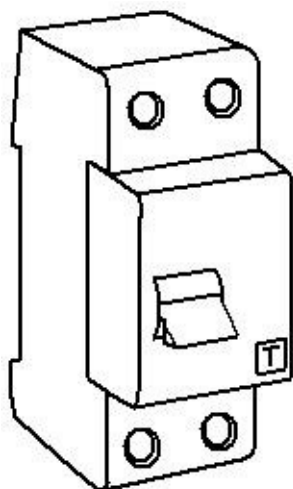

The different models have a bit difference in their sizes , appearance and function. The charging station can be installed by yourself according to the following installation procedure.

## 1.6 Cleaning and maintenance

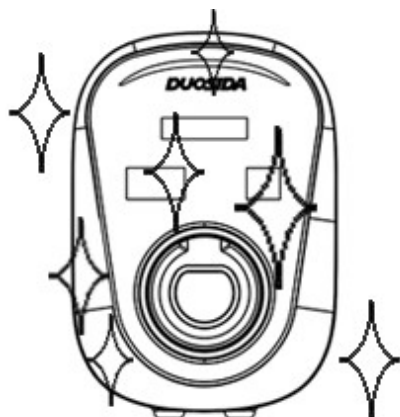

Charging station must only be cleaned using a dry cloth.



Maintenance must be checked regularly.

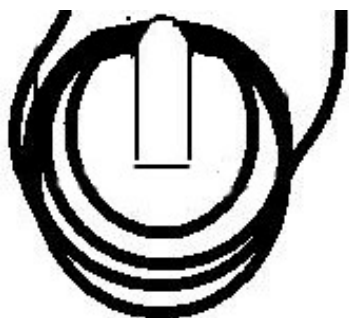

Cable must be checked regularly if there is any damage or aging phenomenon.

# 1.7 Introduce

## 1.7.1 Product information

**DUOSIDA**  
**WALL BOX**

MANUFACTURER :	DUOSIDA
MODEL NUMBER :	2030-SES-32-O-3
SERIAL NUMBER :	XXXXXXXX
DATE OF MANUFACTURE :	XXXX.XX.XX
RATED SUPPLY VOLTAGE :	400V/AC 50/60HZ
RATED OUTPUT VOLTAGE AND CURRENT :	400V/AC,32A,22KW
NUMBER OF PHASES :	THREE-PHASE
IP CODE :	IP55(STORAGE) IP54(MATED WITH VEHICLE)
OPERATING TEMPERATURE:	-30°C~+50°C

DANGER:High Voltage.Please don't open the cover  
WARNING:Only for charging battery electric vehicles and plug-in hybrid electric vehicles  
WARNING:Don't unplug or plug in the plug in the case of electricity

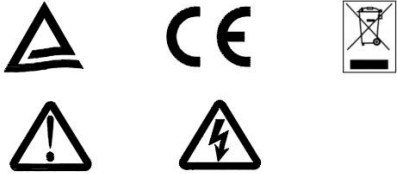

**DUOSIDA**  
**WALL BOX**

MANUFACTURER :	DUOSIDA
MODEL NUMBER :	2080-SES-32-5C-3
SERIAL NUMBER :	XXXXXXXX
DATE OF MANUFACTURE :	XXXX.XX.XX
RATED SUPPLY VOLTAGE :	400V/AC 50/60HZ
RATED OUTPUT VOLTAGE AND CURRENT :	400V/AC,32A,22KW
NUMBER OF PHASES :	THREE-PHASE
IP CODE :	IP55(STORAGE) IP54(MATED WITH VEHICLE)
OPERATING TEMPERATURE:	-30°C~+50°C

DANGER:High Voltage.Please don't open the cover  
WARNING:Only for charging battery electric vehicles and plug-in hybrid electric vehicles  
WARNING:Don't unplug or plug in the plug in the case of electricity

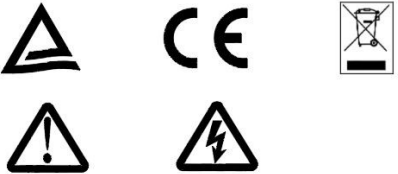

## 1.7.2 The dimensions

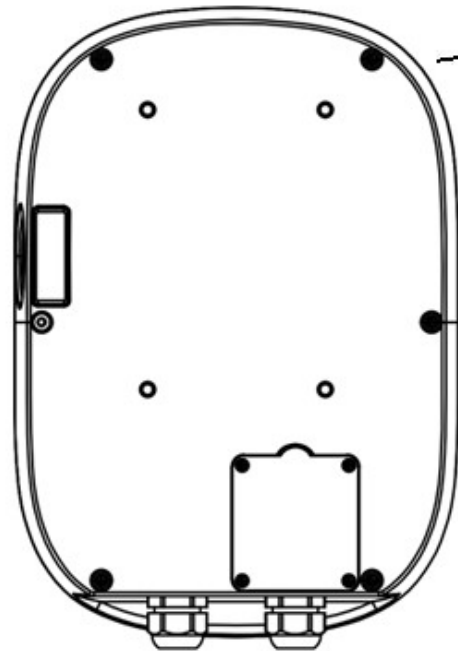
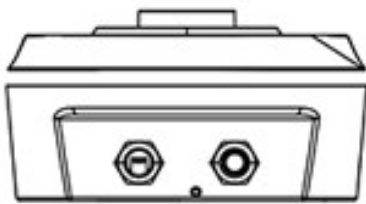
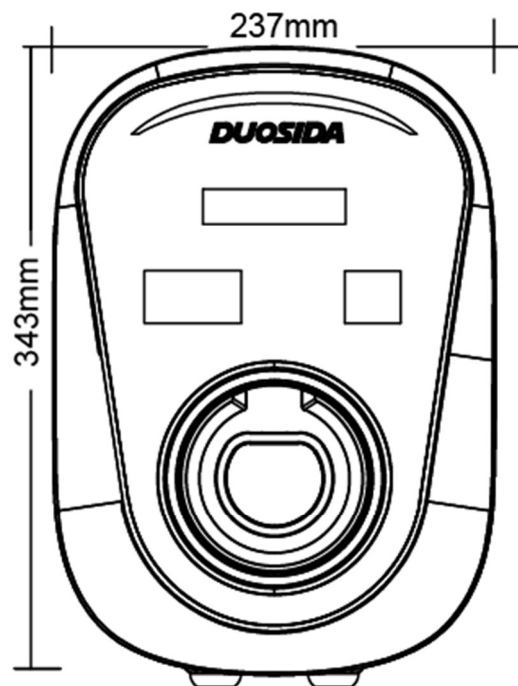
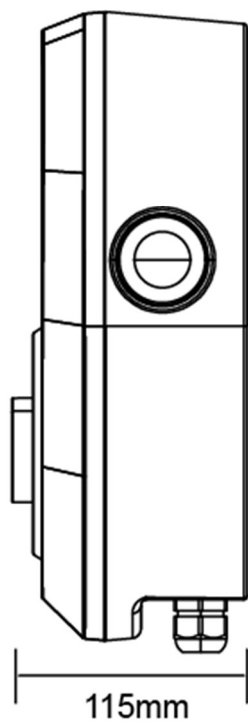

### 1.7.3 Drawing

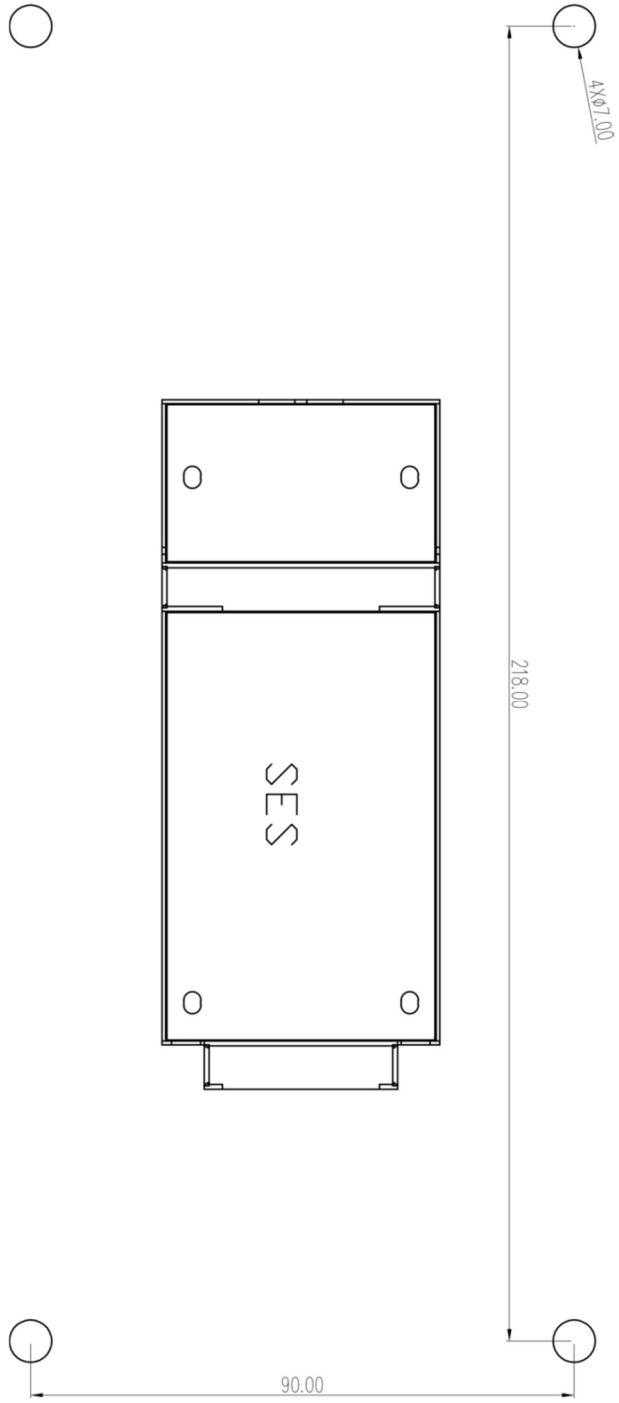

Installation drawing

## 1.7.4 Mounting plate



Mounting plate

Fixed behind the charging station housing



Mounting plate

Fixed to wall



## 1.7.5 Expansion bolts and screws



Screws and tools for fixing charging station



Hook: it is used to wind and fix charging cable

## 1.7.6 Charging station body



## 1.7.7 Charging plug



V4-DSIEC2b-EV32P



V4-DSIEC2e-EV32P

Charging gun : Provide 16A / 32A for choosing

Superior protection performance, the protection level reaches IP54

(working state)

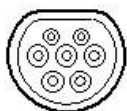

## 1.8 The installation procedure

### 1.8.1 Installation tools

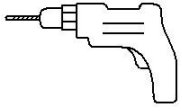

Electric drill



Wrench

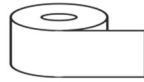

adhesive tape



bolt driver

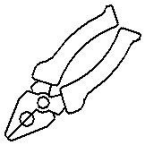

Pliers

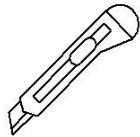

Knife



scissors



pencil



screw

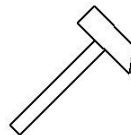

hammer

## 1.8.2 Installation process

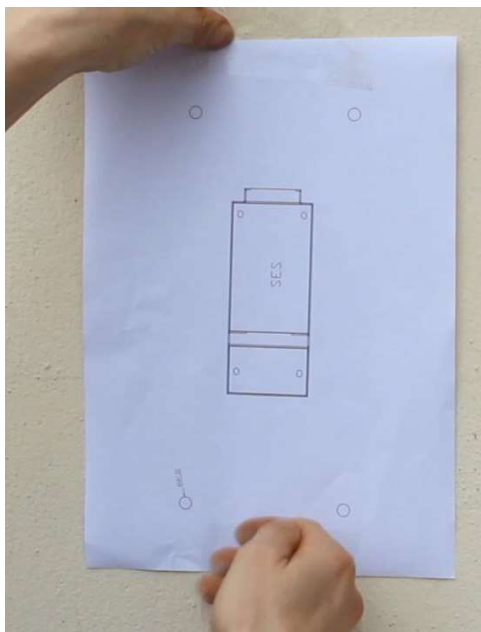

1. Stick the drawing on the wall with tape to decide the drilling hole position.

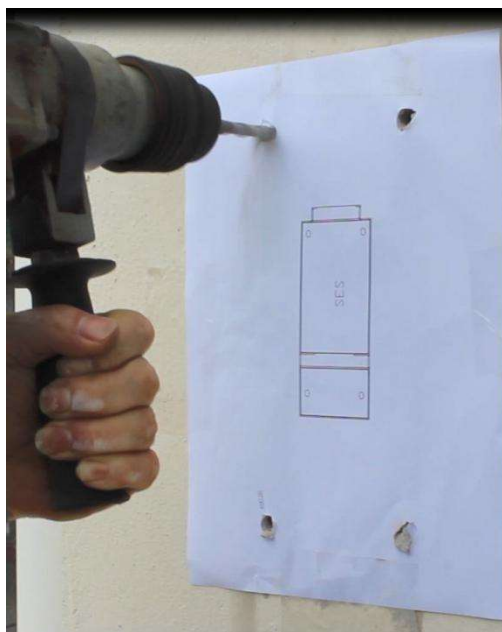

2. Drill holes in the four corners with an electric drill.

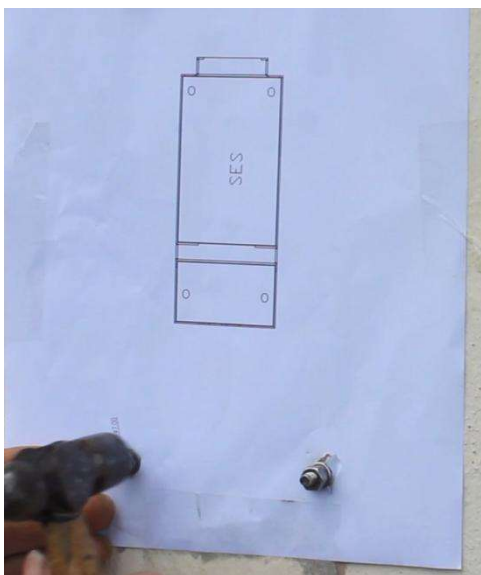

3. Knock the expansion screws in fixed holes with a hammer.



4. Hang the mounting plate on the screws.



5. Tighten the top screws with a wrench.

6. Tighten the lower screws with a wrench.



7. Hang the main body of the mounting ensure outdoor safety plate.

8. Tighten the anti-theft screw to charging station on the



9. Use a pencil to draw the location where the hook needs to be punched.



10. Use an electric drill to make holes in the drawing position.



11. Drive the expansion screws in with a hammer.

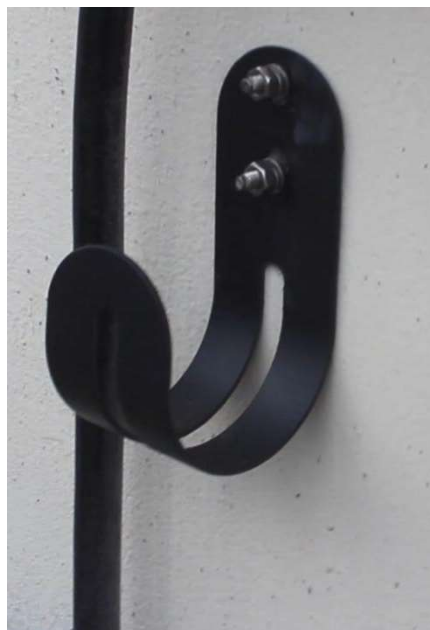

12. Tighten the screws with a wrench.

## 1.8.3 Electrical connection

### Requirements

- Connect the wires to the RCD in sequence
- Pay attention to the correct order when connecting.
- Reversing the polarity of the cables will destroy the electronics of the wallbox.
- Setting the charging current.
- 

**!!!ATTENTION!!!**

**The charging current must never be set higher than the line fuse itself.**

If the wallbox is to be operated with an output of 11 kW, it must be protected with a 20 A fuse (over current protection).

If the wallbox is to be operated with an output of 22 kW, it must be protected with a 40 A fuse (over current protection).



## 1.9 First commissioning

- Pay attention to release the emergency stop switch. Arc-LED and cyclo-LED is blue.
- The nameplate is located to the left of the charger.
- You can start charge with plug in charging gun or use the APP.
- the power supply has been established when arc-LED blink and cyclo-LED often on.

## Explanation of the different light signals

Condition	Arc-LED light	Cyclo-LED light	Remarks
<b>E-stop</b>	Red	Red	
<b>Standby</b>	Blue (flashing)	Blue (flashing)	
<b>Prepare charging</b>	Green	Green	
<b>Charging</b>	Green	Green (flashing)	
<b>End of charging</b>	Green	Blue	
<b>Electric leakage</b>	Red (flashing)	Red (flashing)	
<b>Over voltage</b> <b>Under voltage</b>	Red	Blue	
<b>Overcurrent protection</b>	Red	Green	
<b>Over temperature protection</b>	Red (flashing)	Blue (flashing)	
<b>Hardware failure</b>	Red	Green (flashing)	
<b>Power off</b>	No light	No Light	

## **Before the first commissioning:**

According to "Ordinance on general conditions for grid connection and its use for electricity supply in Low voltage (Low Voltage Connection Ordinance - NAV) " in §19 the following points have to be clarified with the network operator:

*„Section 19 Operation of electrical systems, consumables and charging devices, own systems*

*(1) The system and consumables are to be operated by the connector or user in such a way that faults occur other connectors or users and disruptive repercussions on network operator facilities or Third parties are excluded.*

*(2) Extensions and changes to systems as well as the use of additional consumer devices are the Notify network operators if this increases the capacity to be maintained or with network repercussions is to be expected. Charging devices for electric vehicles are also prior to commissioning to communicate. Their commissioning also requires the prior consent of the network operator, if their total rated power exceeds 12 kilovoltampere per electrical system; is the network operator in this case, obliged to express itself within two months of receiving the notification. Is that true Network operator, he has the impediment, possible remedial measures of the network operator and the Connected party or user and a time required for this by the network operator. The network operator can regulate details of the content and form of the messages.*

*(3) The connector or user must notify the network operator before setting up his own system do. The connectors or user must take appropriate measures to ensure that his Own plant no harmful repercussions in the electricity supply network are possible. The connection of own systems is to be coordinated with the network operator. This can be the connection of compliance with the make it dependent on measures to be taken to protect against reverse voltage in accordance with Section 20. "*

Before the first commissioning with an electric car the following tests must be carried out with an adapter for vehicle simulation (CP) according to VDE 0122-1:

AC charging		
Measurements according to DIN VDE 0105-100 - recurrent tests in operation		
Measurements		
The following tests are to be carried out with an adapter for vehicle simulation (CP) according to VDE 0122-		
Measurement task	measurement method	values
Continuity of the conductors	Resistance measurement of the conductors	PE <1.0 Ω PA <0.1 Ω
Insulation resistance of the protective conductor to neutral and outer conductors	Measurement of the insulation resistance	≥ 1.0 MΩ
Evidence of the effectiveness of the protective measure is by means of Test adapter in vehicle condition C		
Proof of the effectiveness of the protective measure with residual current device IΔN ≤ 30 mA.	RCD Typ A *1 RCD Typ EV RCD Typ B	IΔN ≤ 30  and note manufacturer's instructions
Proof of the effectiveness of the protective device in the event of a short circuit by measuring the internal resistance ZL-N	measuring the internal resistance	$Z_L = \frac{2}{3} \frac{U_N}{I_A}$
Optional		
Measurement of the protective current	f.e. with clamp ammeter	$I_{lim} = 0.4 \times I_{DN}$
Measurement of the neutral conductor	f.e. with clamp ammeter	$I_{lim} = I_N$
Checking the loading sequence		
Trials loading process according to VDE 0122-1		
Vehicle condition	functional test	result
Status A	no vehicle connected	Yes / No
Status B	vehicle connected, but not ready to load	Yes / No
Status C	vehicle connected and ready for charging, ventilation of the loading area is not required	Yes / No
Status D	vehicle connected and ready for charging, ventilation of the loading area is required	Yes / No
Status E	Failure - short circuit CP - PE via internal diode (charging of DC voltage)	Yes / No

\* 1 Observe notes in DIN VDE 0100-722 (VDE 0100-722): 2016-10

(For planning, installation, operation and use, please follow the "Der Technische Leitfaden – Ladeinfrastruktur / Elektromobilität (Version 3)" [Editor: DKE, bdew, ZVEH, ZVEI, & VDE])

## 1.10 Environment

- This device is used to charge electrically operated Vehicles and is subject to the EU directive 2012/19 / EU on waste electrical and electronic equipment(WEEE).
- Disposal must be according to national and regional Regulations for electrical and electronic equipment respectively.
- Old devices and batteries must not be disposed of with household waste or bulky waste. Before the device disposed of should it be rendered inoperable.
- Dispose of the packaging material in the Your region's usual collection container for cardboard, paper and plastics.

