

CR10XY

(CoreXY conversion kit for the Cr-10 3d printer)
printer)

ASSEMBLY MANUAL



STEP BY STEP INSTRUCTION MANUAL

BY ADITIVA 3D

V1.0



ADITIVA3D

Content

Chapter 1	Intro	3
Step 1.1	What is included in this kit?	3
Step 1.2	Additional printable parts	4
Step 1.3	Required tools	5
Chapter 2	Disassembling CR-10	6
Step 2.1	Disconnecting wires	6
Step 2.2	Removing original Z axis system	6
Step 2.3	Removing original Top frame	7
Step 2.4	Y axis and heatbed assembly	8
Chapter 3	Preparing frame	10
Step 3.1	Building Bottom Frame	10
Step 3.2	Installing other frame parts	12
Step 3.3	Preparing Top frame	16
Step 3.4	Installing Top and Bottom frame	19
Chapter 4	CoreXY system	23
Step 4.1	Preparing X axis	23
Step 4.2	CoreXY system installation	28
Step 4.3	Hotend mount	38
Chapter 5	Installing Heatbed and Z axis	40
Step 5.1	Heatbed bracket	40
Step 5.2	Installing Z axis elements + Heatbed	40
Chapter 6	Electronics and firmware	50
Step 6.1	Electronics	50
Step 6.2	Firmware	51

Chapter 1 Intro

Step 1.1 What is included in this kit?

Congratulations on purchasing the CR10XY Conversion Kit, designed to transform your regular stock 3D printer into a high-performance CoreXY 3D printer. With this kit, you will experience enhanced speed, accuracy, and overall print quality, thanks to the inclusion of high-quality CNC metal parts, linear rails, and extra stepper motors.

Compatibility:

The CR10XY Conversion Kit is specifically designed for Cr-10, Cr-10 Pro, and Cr-10 V2 versions. If you own any of these models, you are in the right place to upgrade your 3D printing experience.

Contents:

The CR10XY Conversion Kit includes all the required metal parts and additional hardware necessary to complete the assembly. We have taken care to ensure that all the components are of the highest quality to guarantee durability and optimal performance. However, please note that there are certain 3D printed parts essential to finishing the assembly. To assist you, we have provided the corresponding STL files for these parts that need to be printed.

Step-by-Step Instructions:

This manual serves as a comprehensive, easy-to-follow guide, providing you with step-by-step instructions for the entire assembly process. From the initial disassembly of your stock 3D printer to the installation of the CR10XY Conversion Kit components, each step is clearly explained and accompanied by detailed illustrations. By following these instructions closely, you will be able to complete the upgrade efficiently and effectively.

Enhanced Performance:

Once the CR10XY Conversion Kit is successfully installed, your 3D printer will be equipped with advanced features that allow for faster and more accurate prints. The addition of linear rails ensures smoother and more stable movement of the print head, minimizing vibrations and artifacts. The extra stepper motors contribute to improved performance, enabling precise control of multiple axes.

We are confident that the CR10XY Conversion Kit will elevate your 3D printing capabilities, bringing you closer to professional-grade results. Should you have any questions or encounter any difficulties during the assembly process, our customer support team is available to assist you.

Thank you for choosing the CR10XY Conversion Kit. Let's get started with the assembly and unlock the true potential of your 3D printer!

Step 1.2 Additional printable parts

There are few printable parts for finish this build, since they will be provided as STL digital format, they are subject to upgrades and few more will be added in the future, please check for regular updates.

- ✓ X endstop bracket

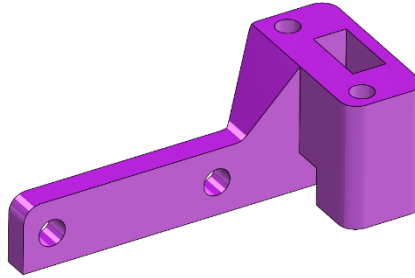

Figure 1 X axis endstop bracket

- ✓ Y endstop bracket



Figure 2 Y Axis endstop bracket

- ✓ Z endstop bracket + Z limit

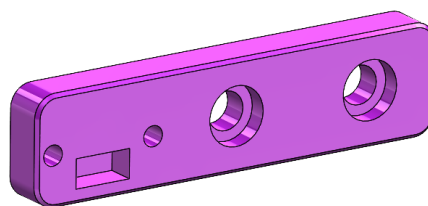

Figure 3 Z axis endstop bracket

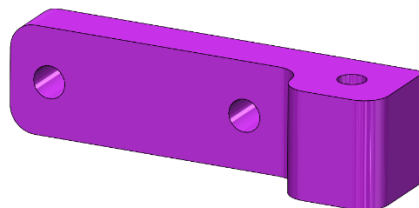

Figure 4 Z Limit bracket

- ✓ Corner bracket 2020

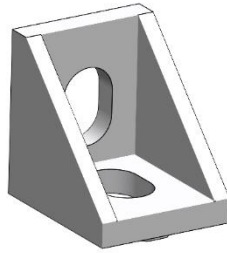

Figure 5 Corner bracket

Step 1.3 Required tools

In order to fully install this kit, you will need the next tools:

- ✓ Set of Allen keys
- ✓ Adjustable wrench or wrench kit
- ✓ Measuring tape
- ✓ Flat file or low grit sandpaper (100 grit)
- ✓ Vernier caliper
- ✓ Metal ruler (for alignment)
- ✓ Square ruler

Chapter 2 Disassembling CR-10

In order to get ready to install this kit, you have to disassembly various segments of the original 3d printer, this part will guide you through entire process of preparation and getting ready to install new parts.

In this part of the process, various electrical components will be temporarily disconnected for practical purposes, you must install them later though.

*Please be aware some original parts will be discarded and won't be installed.

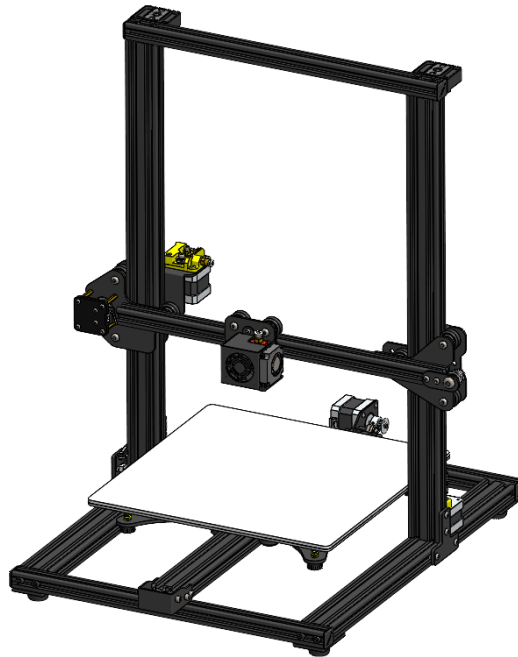

Figure 6. Assembled Cr-10

Step 2.1 Disconnecting wires

- ✓ **DISCONNECT ELECTRICAL POWER FROM THE MACHINE BEFORE DOING THIS STEP.**
- ✓ Remove lid of electronics box and proceed to disconnect all wires going to the hotend harness, Z motor, extruder.
- ✓ *Tip: take as many pictures as possible of connectors and wires in order to reconnect later in assembly steps, labeling is also very useful.
- ✓ Put lid back on its place and secure with its own screws.

Step 2.2 Removing original Z axis system

- ✓ Disconnect Z motor cable.
- ✓ Using an allen key remove Z motor bracket (m3 screws), leadscrew and Z nut (2 x m3 screws).
- ✓ Also remove Z endstop (including plate), remove Z endstop cable as well.

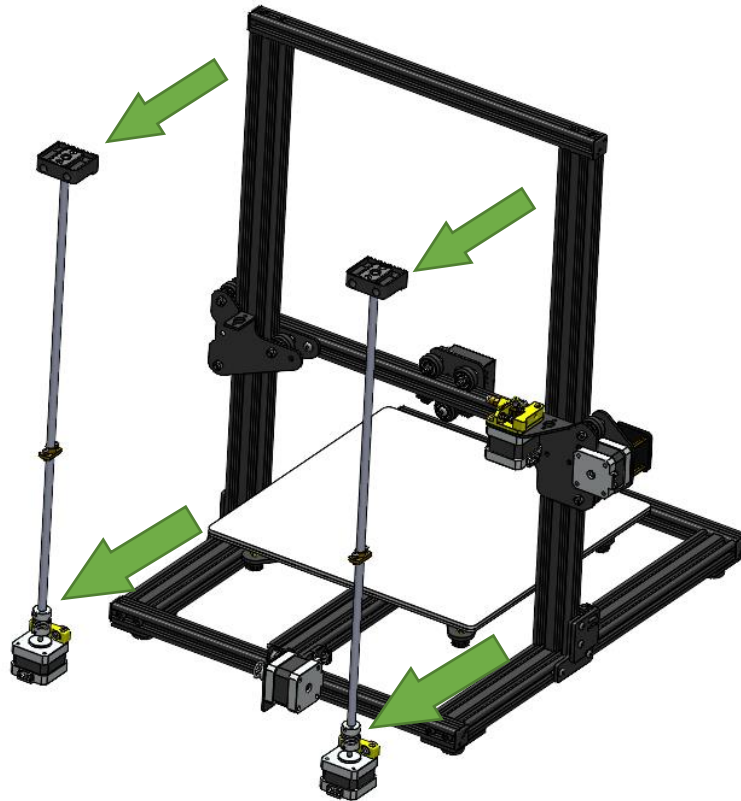

Figure 7 Removing Z axis moving system

- ✓ Items to discard: Z coupler, Z motor bracket, Z endstop bracket, leadscrew, brass nut.
- ✓ Items to save for later use: Z motor, Z endstop (including its 2 x m3 screws)

Figure 8 Remove end caps

Step 2.3 Removing original Top frame

- ✓ Using an Allen key, remove 4 M5 screws from the bottom of both Z columns.
- ✓ Top frame and X axis assembly will be used, discard removed 4 x M5 screws.
- ✓ Remove side T-shape brackets as well.

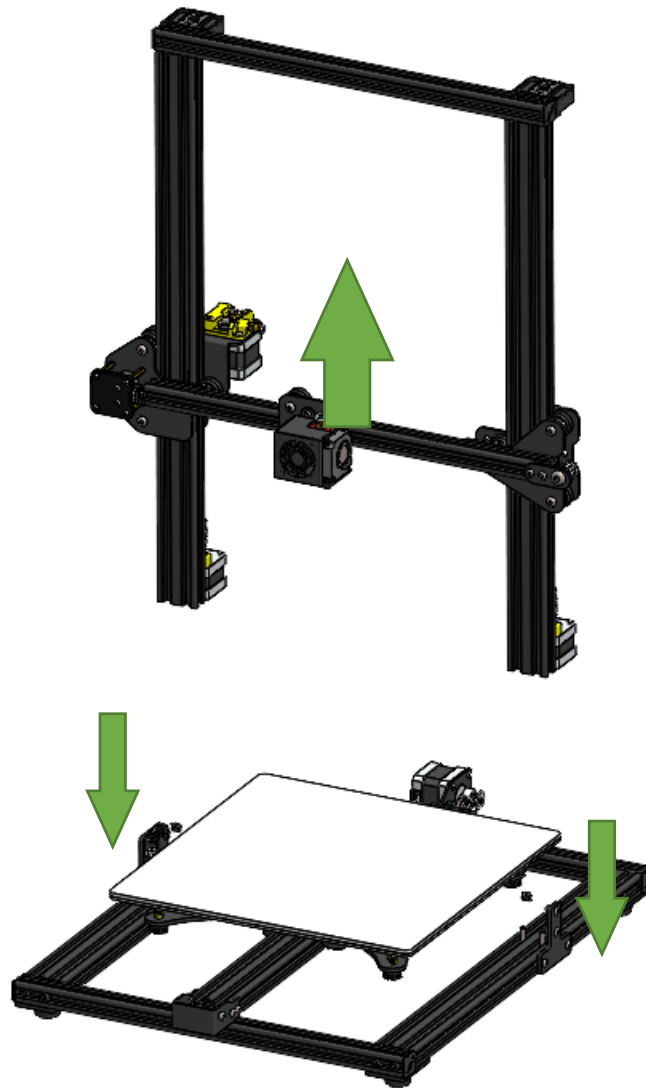

Figure 9 Removing top frame and X axis system

Step 2.4 Y axis and heatbed assembly

- ✓ Using an Allen key, remove 2 x m5 screws that holds Y axis system with heatbed assembly.
- ✓ Save Y axis and heatbed assembly for later use, discard 2 x m5 screws.

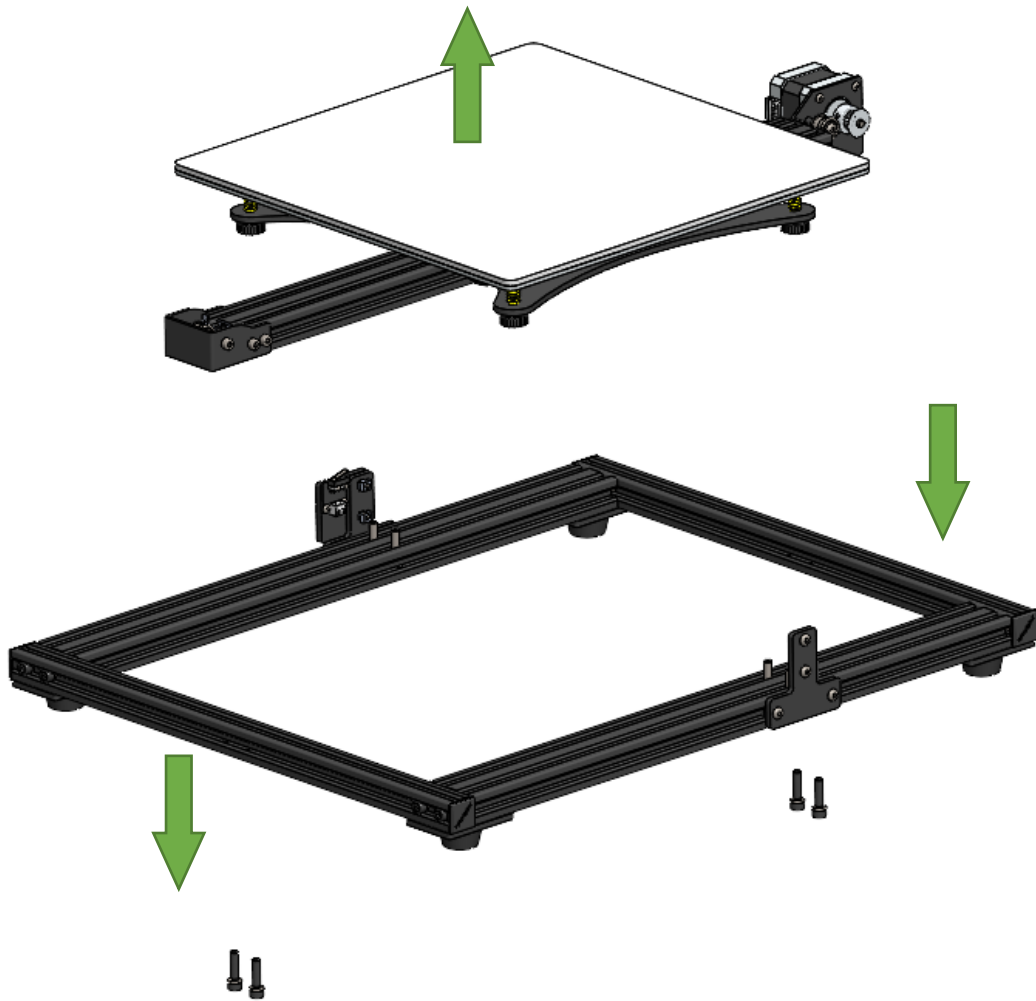

Figure 10 Removing Y axis and heated

Chapter 3 Preparing frame

Step 3.1 Building Bottom Frame

- ✓ Next items from the KIT and Original parts will be used:

ITEM	ITEM DESCRIPTION	Quantity	Type
1	Bottom Frame Assembly	1	Assembly
2	P3L bracket	1	Kit
3	P3R bracket	1	Kit
4	M5 x 8 mm Screw	12	Kit
5	M5 Spring nut	12	Kit
6	P5 bracket	2	Kit

- ✓ Mount **P3L** and **P3R** brackets to the **Original Bottom Frame** as shown in the next picture, please be sure that both external frame and bracket face are very well aligned, you can use a metal ruler or one of the aluminum extrusions provided in the kit, in order to check for alignment. Both ends of the frame and the brackets must be flush aligned.
- ✓ Using 03 units of M5x8 mm screws and M5 Spring nuts on each side, left and right sides must be assembled, as shown in the next picture:

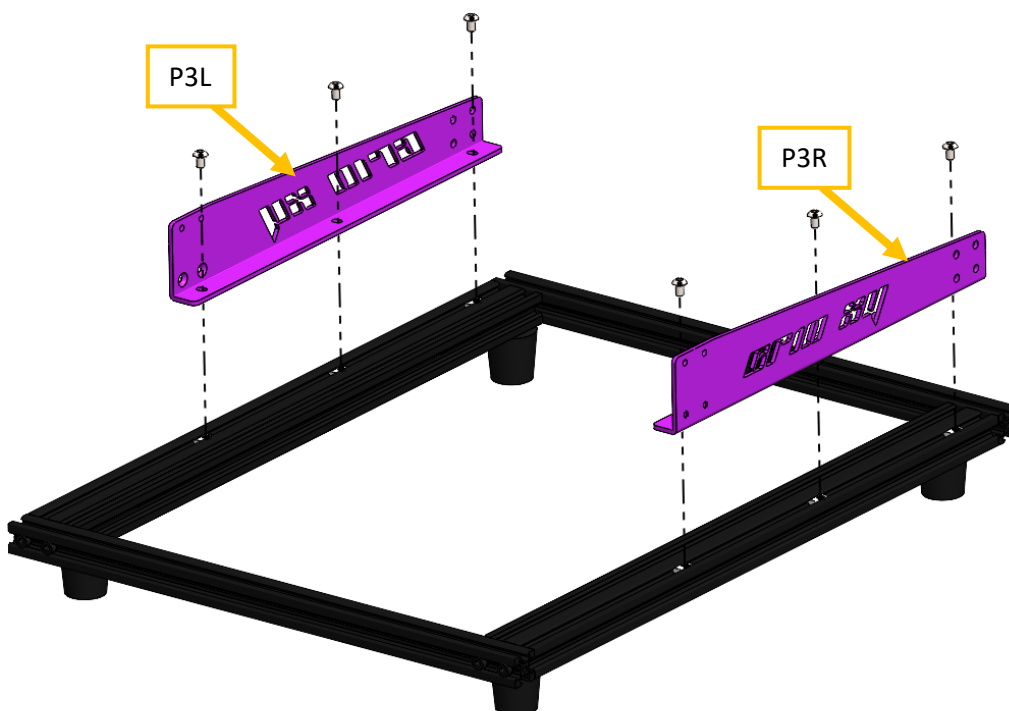

Figure 11 Bottom frame + P3 brackets

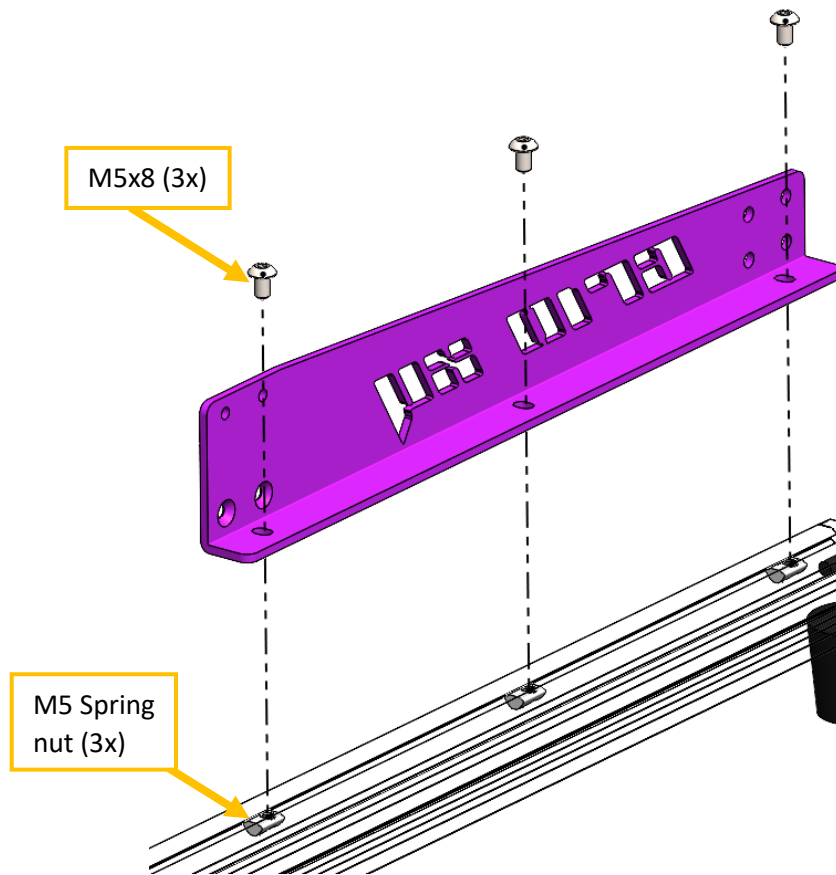

Figure 12 Joint detail with Screws and Spring nuts

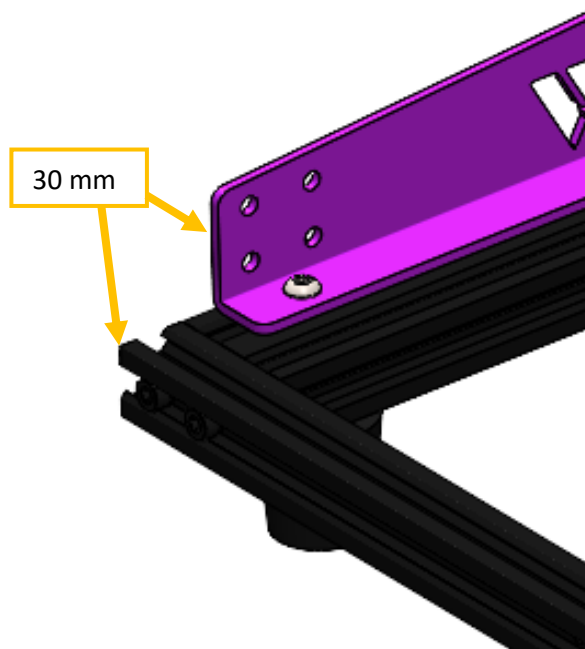

Figure 13 Keep a distance of 30mm between the edge of a frame and the bracket.

- ✓ Flip bottom frame, and install both sides P5 brackets, as shown, using M5x8 Screws and M5 Spring nuts, keeping 65mm from the front side, and 290mm from the back as shown:

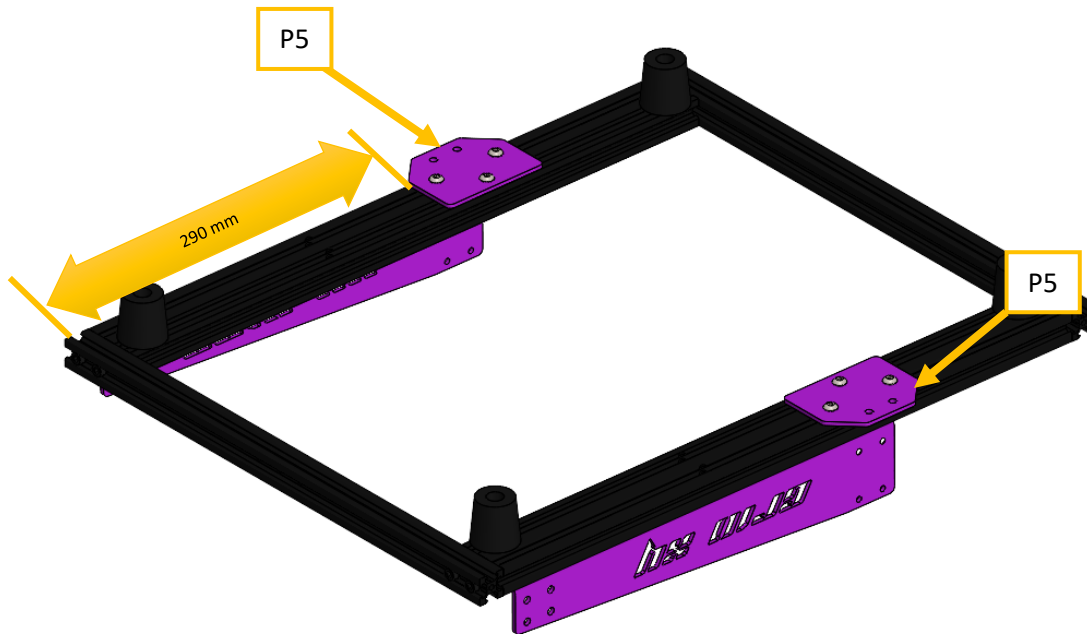

Figure 14 Bottom brackets mounting

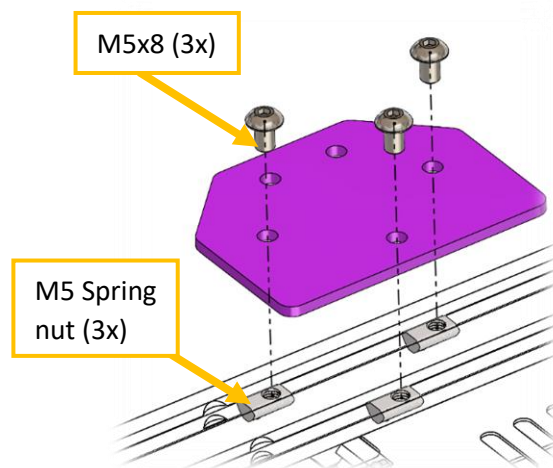

Figure 15 Fixing detail

Step 3.2 Installing other frame parts

- ✓ Next items from the KIT and Original parts will be used:

ITEM	ITEM DESCRIPTION	Quantity	Type
1	Bottom frame with brackets (previous step assembly)	1	Assembly
2	2040 Aluminum Extrusion L=550 mm (560 for V2, V3)	2	Original
3	2020 Aluminum Extrusion L=572 mm	2	Kit
4	M5 x 8 mm Screw	16	Kit
5	M5 x 20 mm Screw	4	Kit
6	M4 x 8 mm Countersunk Screw	4	Kit
7	M4 Spring nut	4	Kit

8	M5 Spring nut	16	Kit
9	P2L Bracket	1	Kit
10	P2R Bracket	1	Kit

- ✓ Install Stock 2040 Aluminum extrusions L=560mm as shown in the next picture, M4 x 8 mm Countersunk screws and M4 Spring nuts will be used, left and right sides must be assembled, extrusions doesn't really need to be correspondent to their original positions, repeat process on the opposite side:

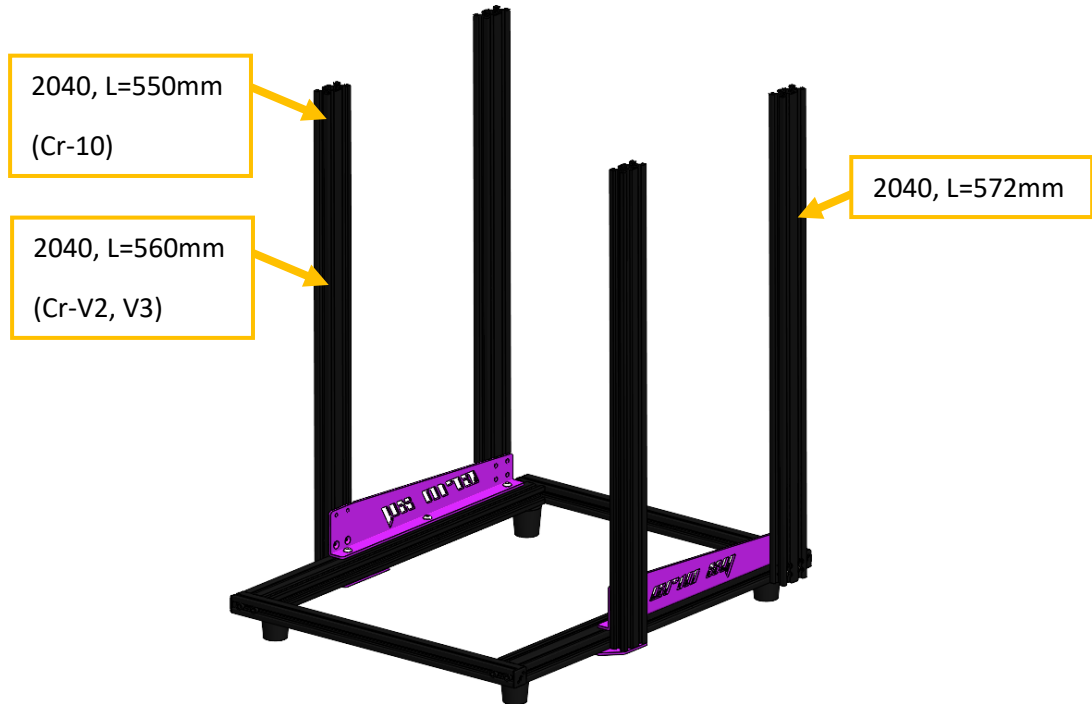

Figure 16 Installing 2040 Alu extrusions to the bottom frame

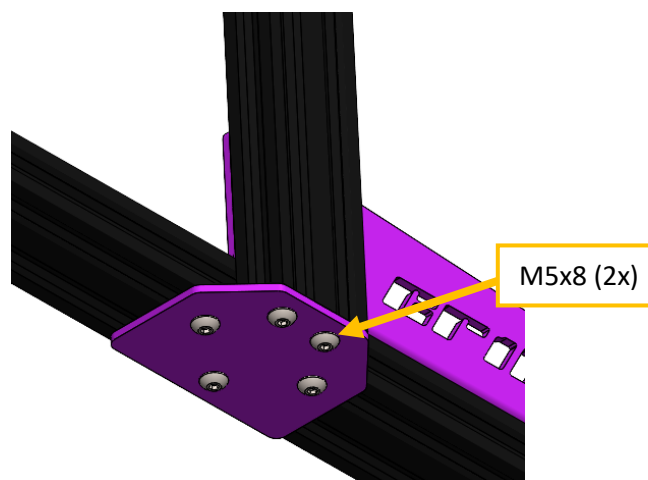

Figure 17 Mounting detail

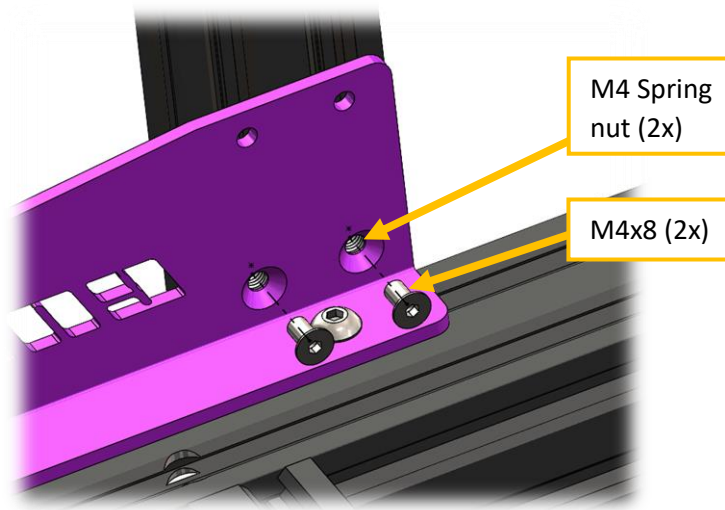

Figure 18 2020 Extrusions L=560mm mounting to bottom frame

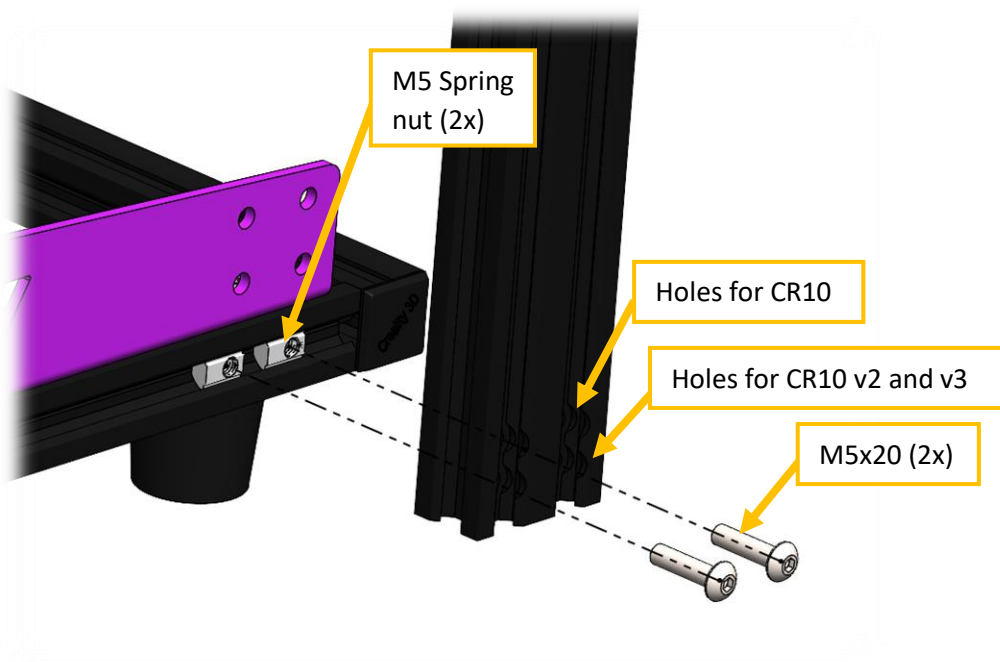

Figure 19 Detail of extrusion mounting

- ✓ Secure the extrusion from the inside of the P3 bracket as shown next:

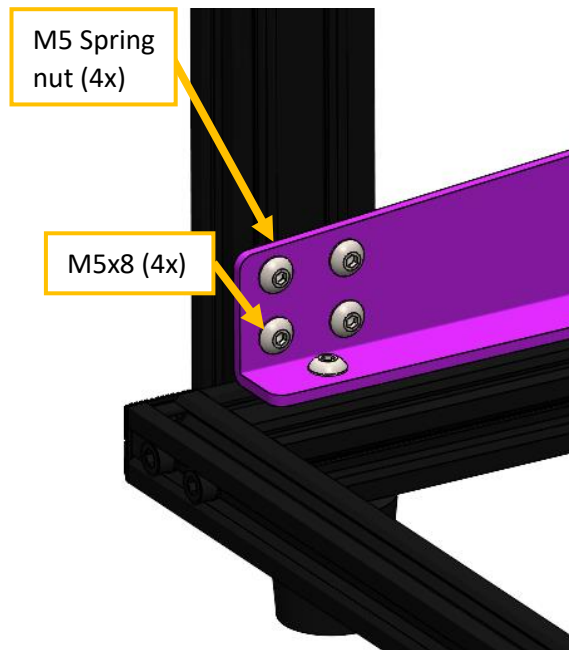

Figure 20 Detail of inner screws fixing

- ✓ Install P2R / P2L brackets as shown, using M5x8 Screws and M5 Spring nuts, repeat process on the left side:

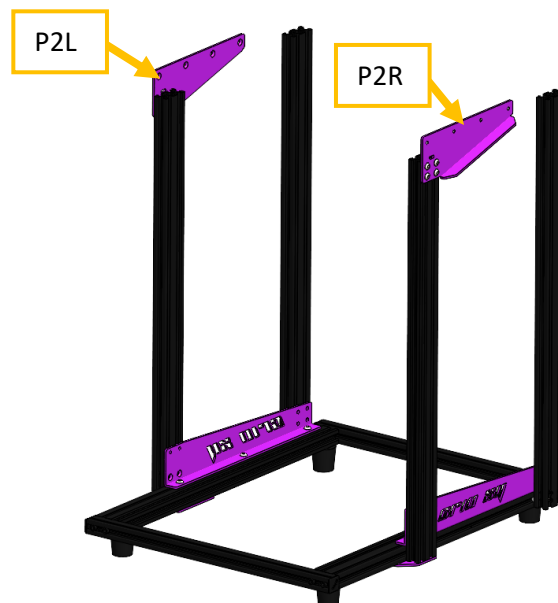

Figure 21 P2R/L bracket position

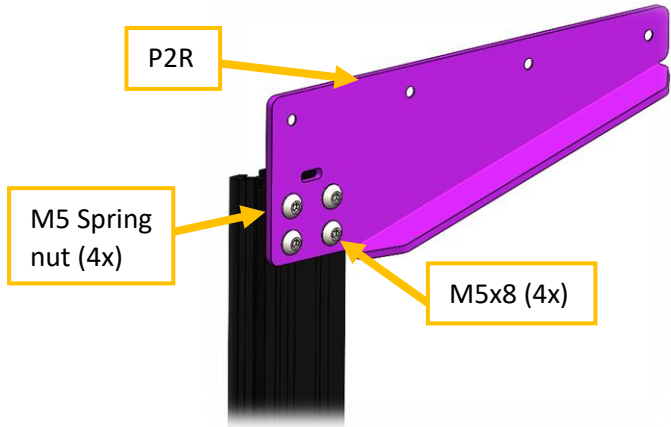

Figure 22 mounting detail for P2R bracket

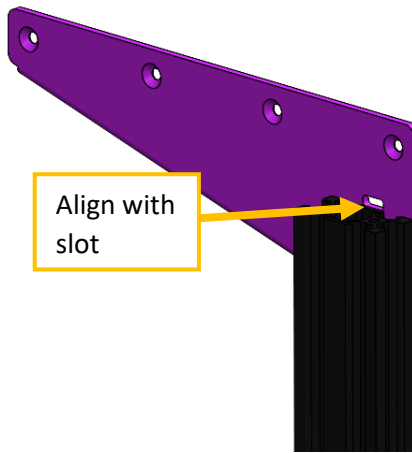

Figure 23 Bracket slot might be aligned with the end of extrusion

Step 3.3 Preparing Top frame

✓ Next items from the KIT will be used:

ITEM	ITEM DESCRIPTION	Quantity	Type
1	2020 Aluminum Extrusion L=475 mm	2	Kit
2	P1 Bracket	1	Kit
4	M5 x 8 mm Screw	6	Kit
5	M5 Spring nut	4	Kit

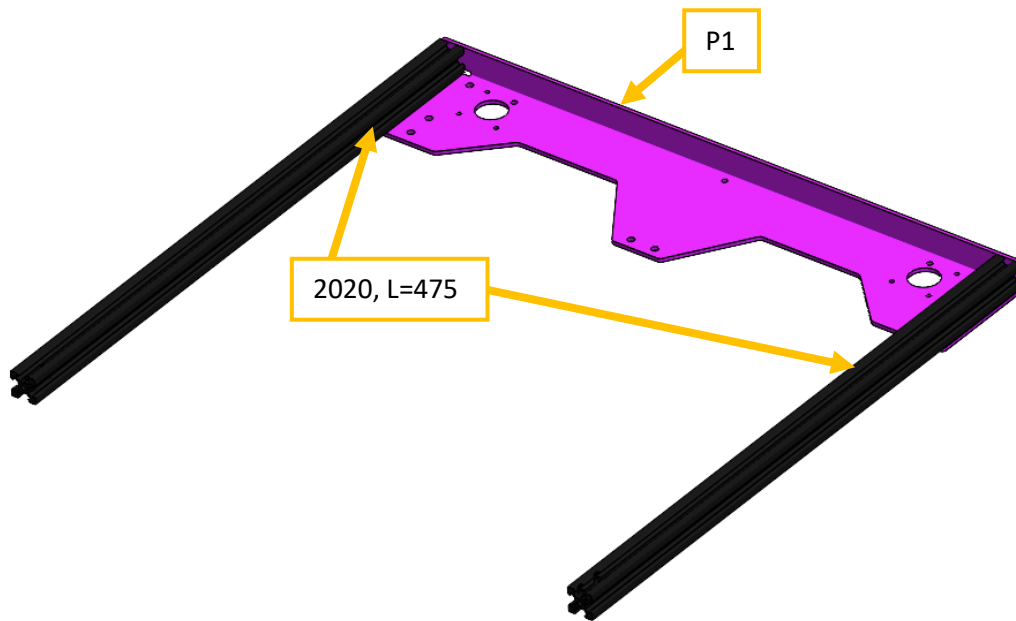

Figure 24 Top frame assembly

- ✓ Face each 2020 aluminum extrusion as shown:

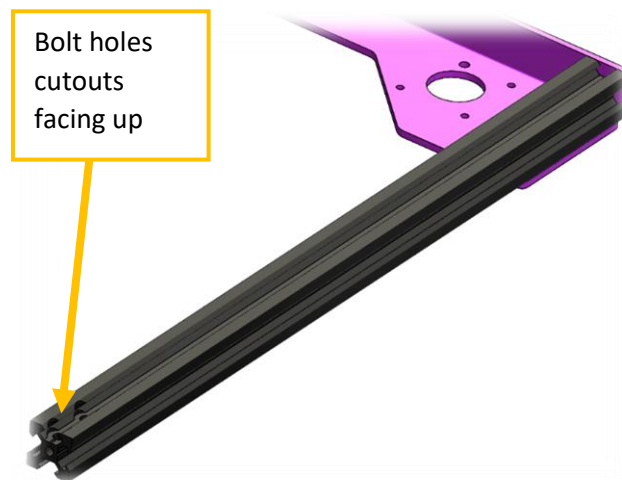

Figure 25 Right side detail for the 2020 extrusion

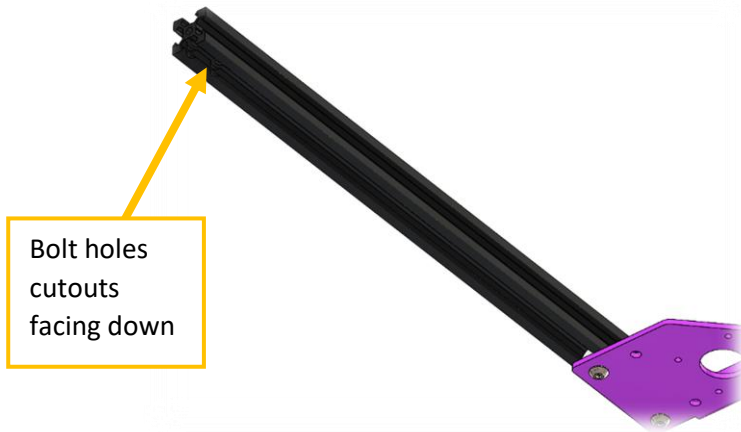

Figure 26 Left side 2020 extrusion detail

- ✓ Insert M5 spring nuts and fix 2020 extrusion to P1 bracket using M5x8mm Screws, repeat process on the left side:

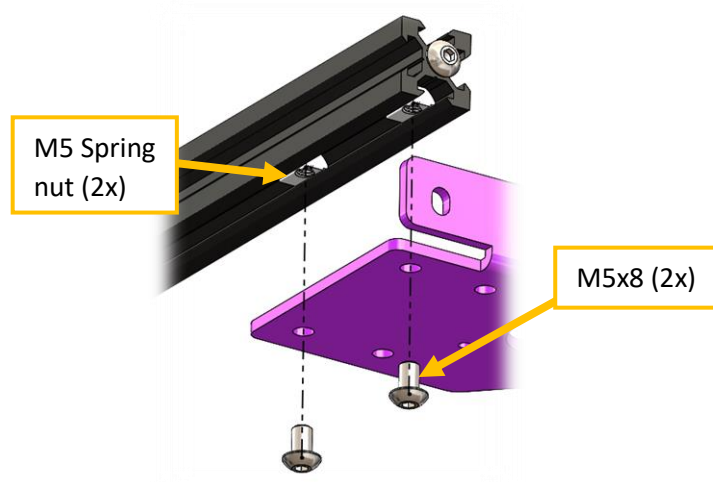

Figure 27 Fixing detail

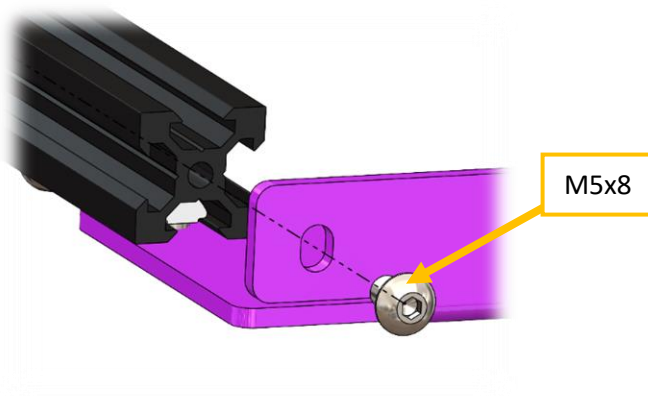

Figure 28 Back screw fixing detail

Step 3.4 Installing Top and Bottom frame

- ✓ Next items from the KIT and Original parts will be used:

ITEM	ITEM DESCRIPTION	Quantity	Type
1	Bottom frame assembly	1	-
2	Top frame assembly	1	-
3	M4 x 8 mm Countersunk Screw	8	Kit
4	M4 Spring Nut	8	Kit
5	M5 x 8 mm Screw	14	Kit
6	2040 Aluminum Extrusion L=475 mm	1	Kit
7	2020 Aluminum Extrusion L=320 mm	1	Kit
8	2020 Corner brackets	4	Printed

- ✓ Mount Top frame over bottom frame assembly as shown in the next picture:



Figure 29 Frame assembly

- ✓ Install top assembly frame using provided M4x8mm Countersunk Screws (8) and M4 Spring nuts (8), also M5x8mm Screws (4):

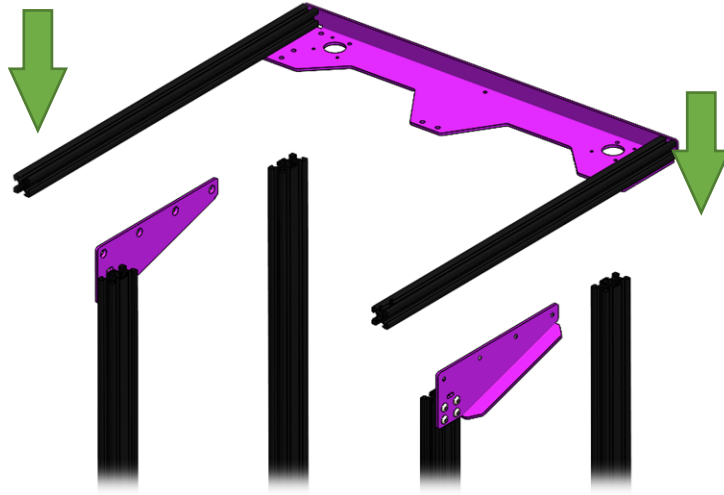

Figure 30 Assembly of top and bottom frames

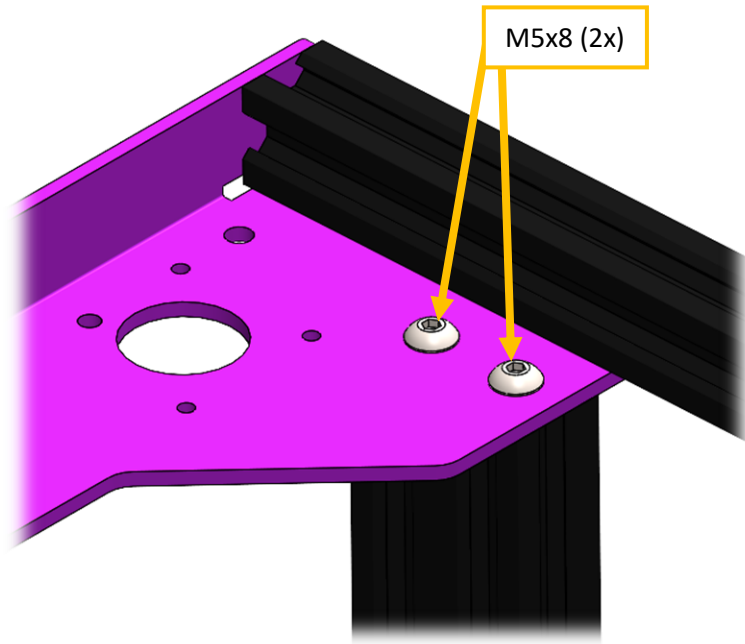

Figure 31 Back joint detail, M5x8 mm screw fixed to 2040 extrusion

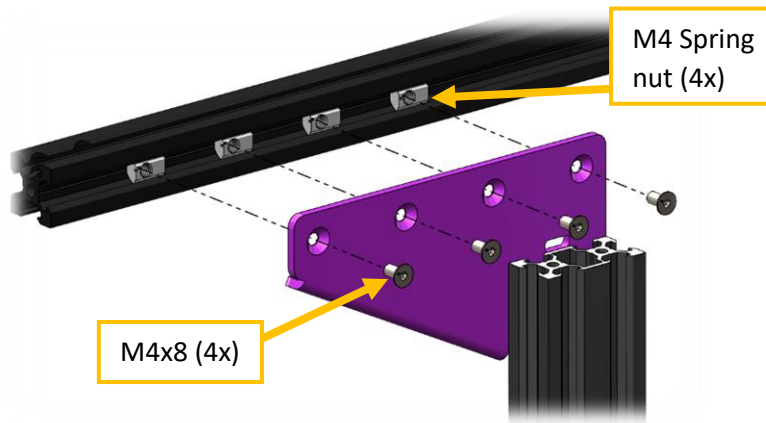

Figure 32 Front joint detail, M4x8 mm screws and nuts

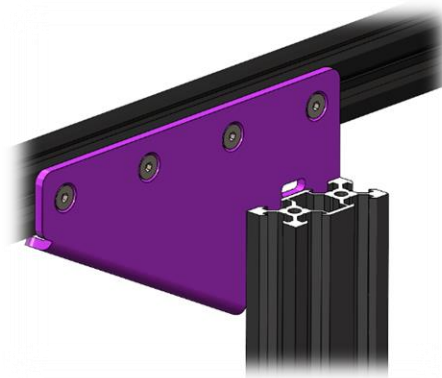

Figure 33 Final finish fixing detail, right side

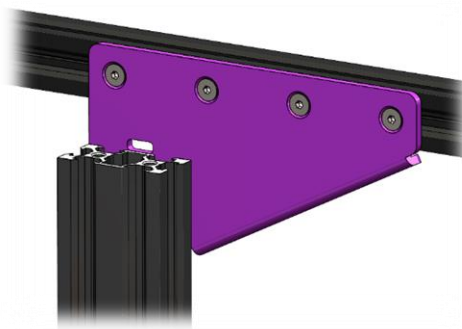

Figure 34 Final finish fixing detail, left side

- ✓ Install 2020 Aluminum extrusion L=320 and 2040 Aluminum extrusion L=542mm as shown, using 2020 Corner brackets, M5x8 screws and M5 Spring nuts:

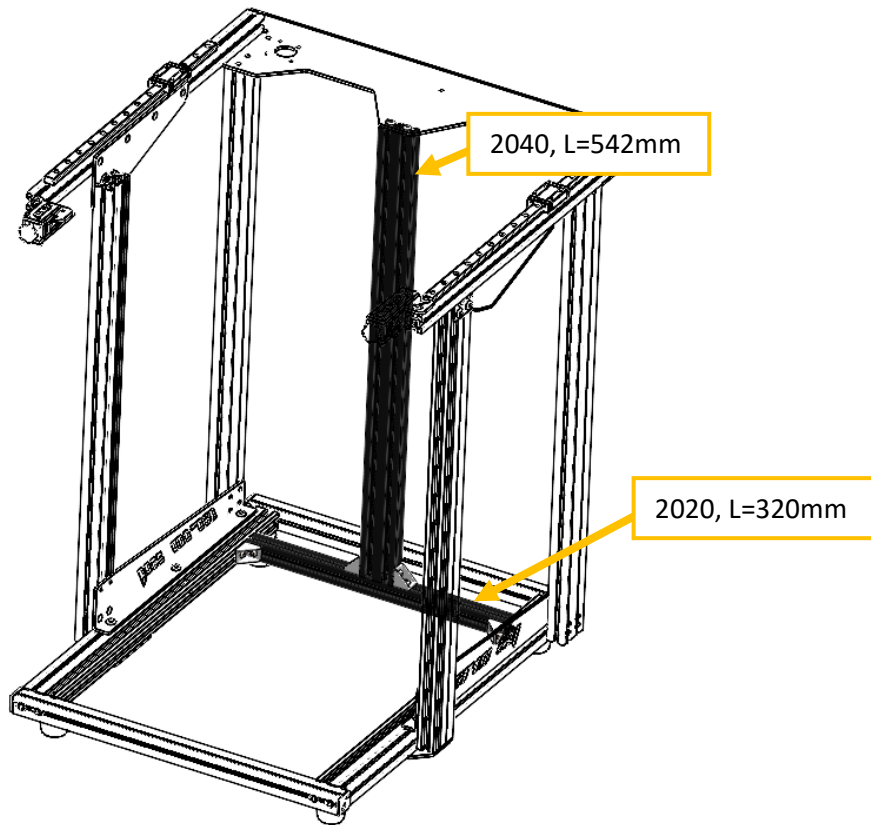

Figure 35 Detail of middle extrusions fixing

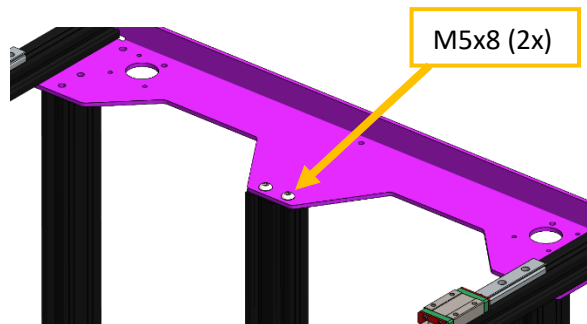
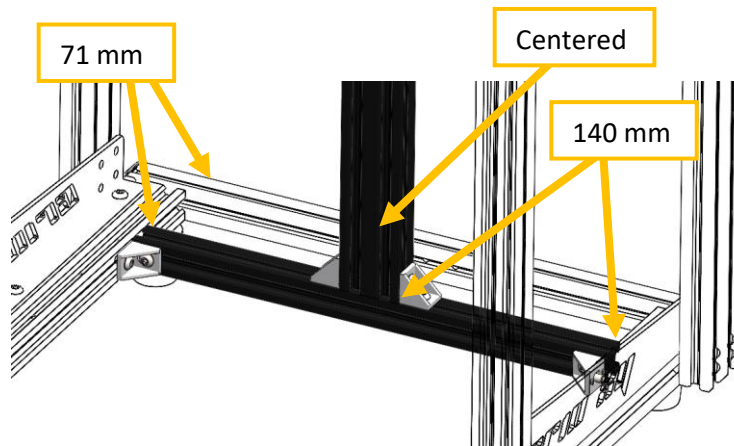

Figure 36 Detail of center extrusion fixing for Cr-10

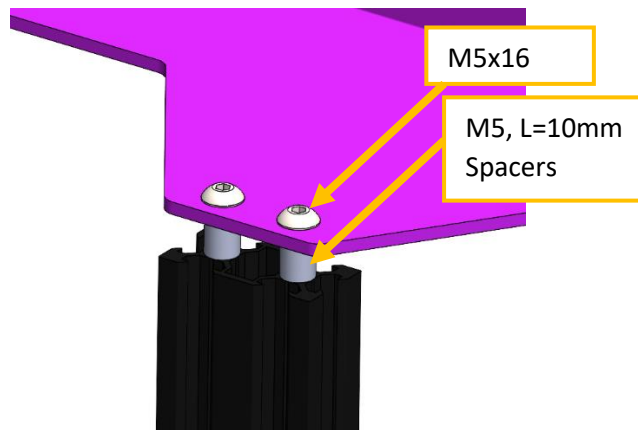

Figure 37 Detail of center extrusion fixing for Cr-10 v2 and v3, use M5x10mm Spacers

Chapter 4 CoreXY system

Step 4.1 Preparing X axis

- ✓ Next items from the KIT and ORIGINAL parts will be used:

ITEM	ITEM DESCRIPTION	Quantity	Origin
1	2020 Aluminum Extrusion, L=415mm	1	Original
2	350 mm Linear rail with slider	1	Kit
3	P8 Bracket	4	Kit
4	P7 Bracket	2	Kit
5	P10 Bracket	1	Kit
6	M5xD8XL10 Spacer	8	Kit
7	M5x8x1 Washer	8	Kit
8	M5x8 Screw	4	Kit
9	M5x20 Screw	4	Kit
10	M5x30 Screw	4	Kit
11	M5 Nylock nut	4	Kit
12	F695RS Bearing	8	Kit
13	M3x8 Socket screw	9	Kit
14	M3 Spring nut	5	Kit
15	M5 Spring nut	8	Kit

- ✓ Take the 2020 Aluminum Extrusion L=415mm (Original X axis bar) and perform a 2mm (approximately) chamfer on the front side, using a flat file or 100 grit sandpaper, as shown:



Figure 38 2020 Alu Extrusion (X axis) with 2mm chamfer on both sides

✓ Follow the next diagrams to build X axis assembly:

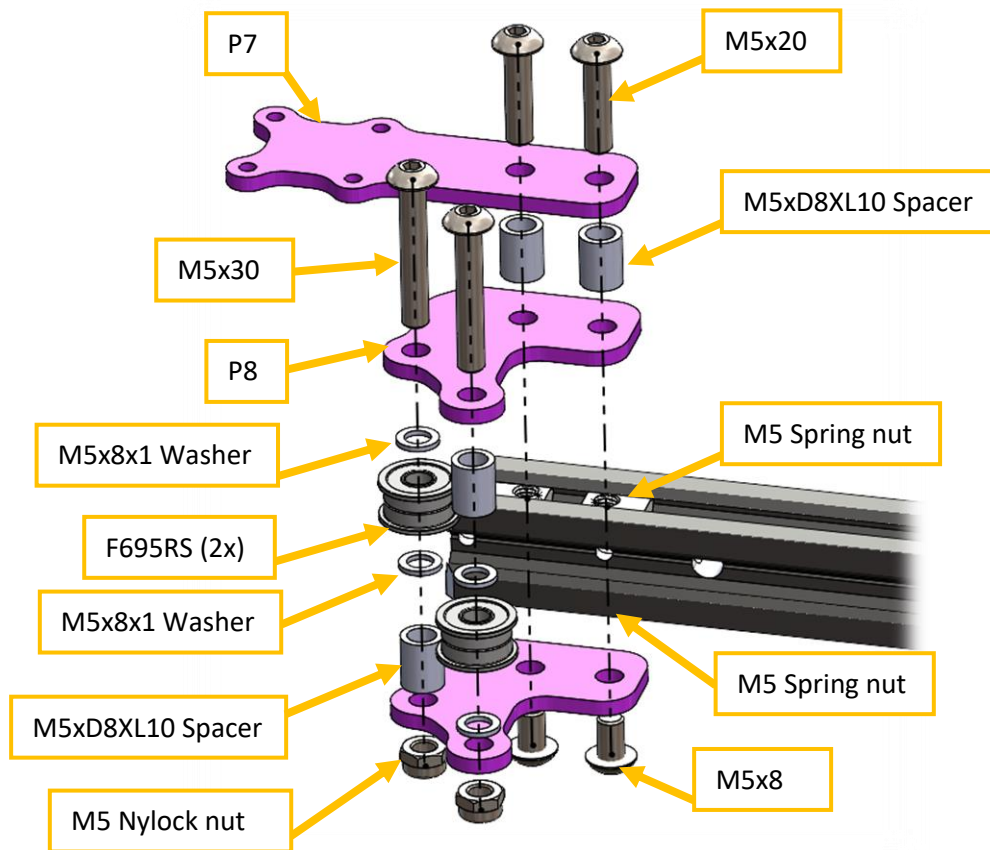

Figure 39 Left side X axis assembly scheme

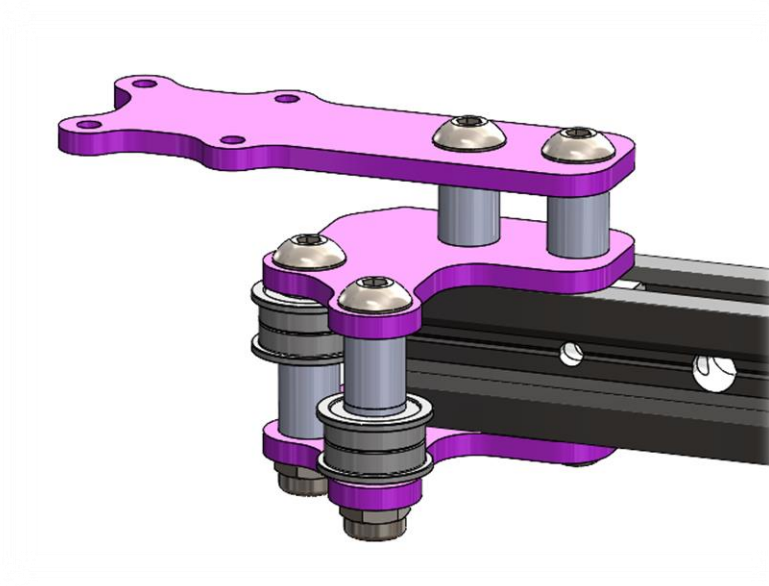

Figure 40 Left side mounted components

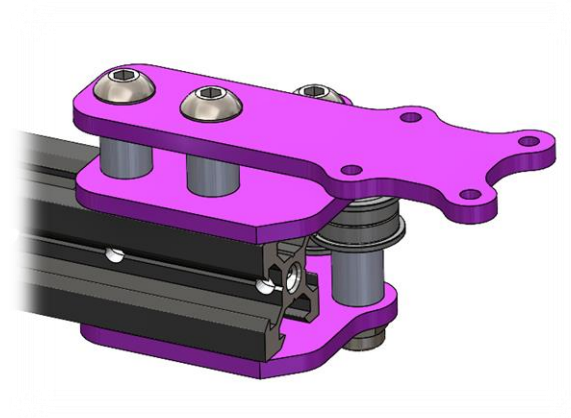

Figure 41 Left side, back view for reference

- ✓ Repeat process for the right side.

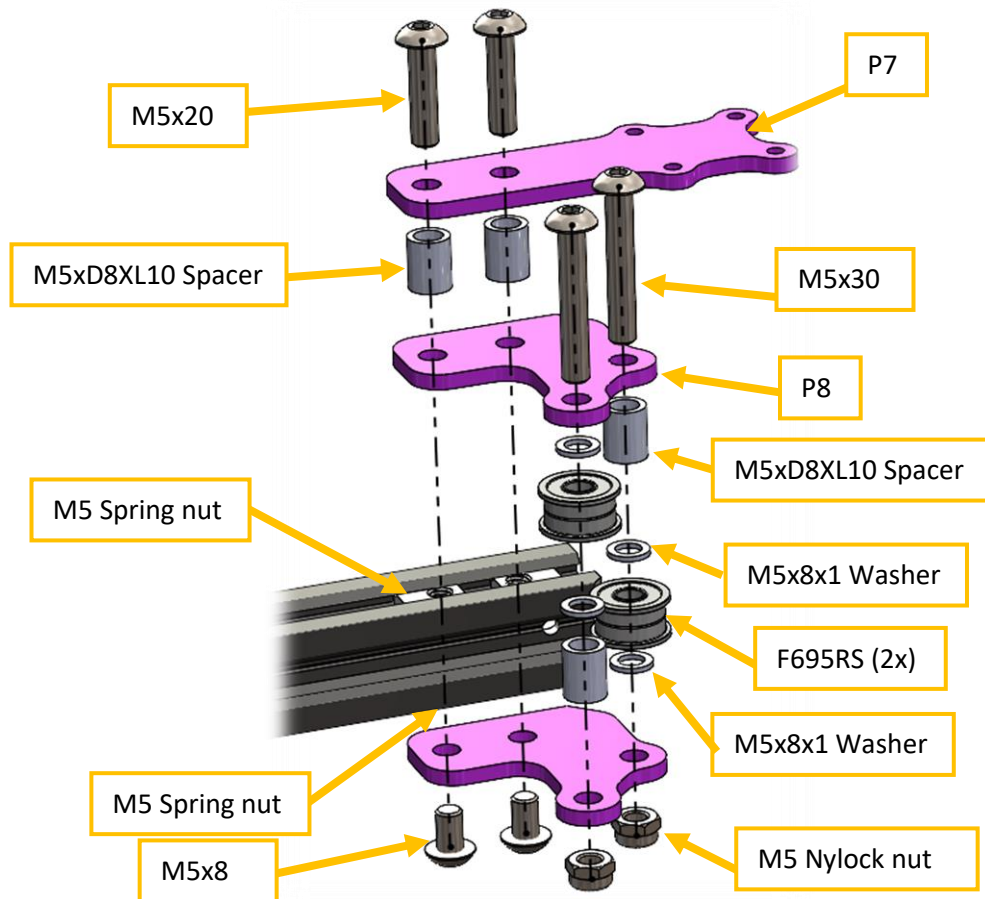

Figure 42 Right side X axis assembly scheme

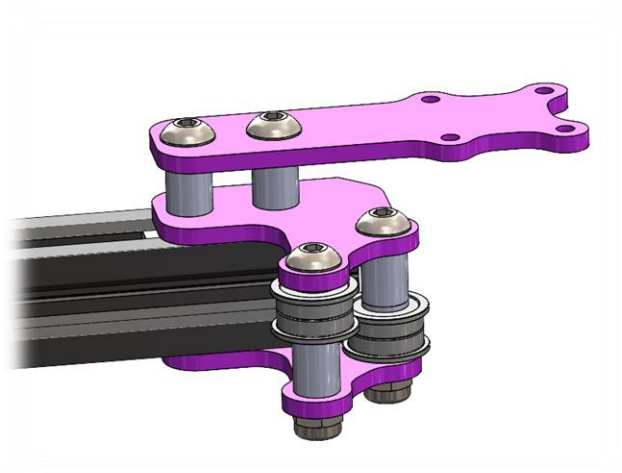

Figure 43 Right side mounted components

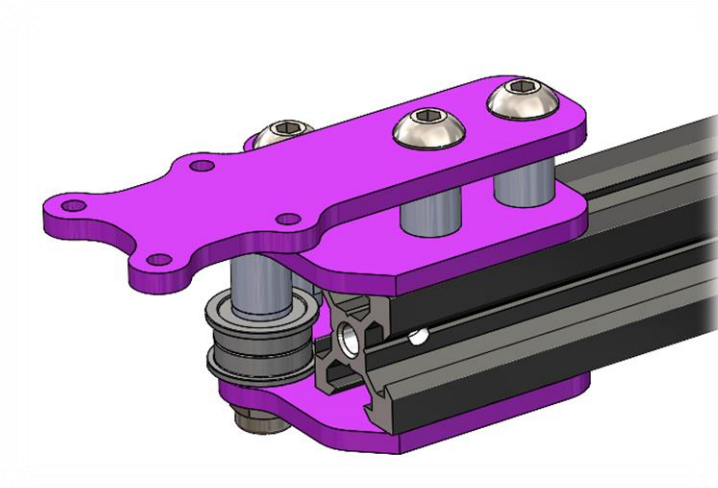

Figure 44 Right side, back view for reference

- ✓ Mount the 350 mm Linear rail with slider to the X axis assembly, using M3x8 Socket Screws and M3 Spring Nuts, Linear rail must be centered with the X aluminum extrusion:
NOTE: Be very careful when installing slider part of the rail, don't drop any ball, it might result in a damaged rail if 1 or 2 balls were dropped.

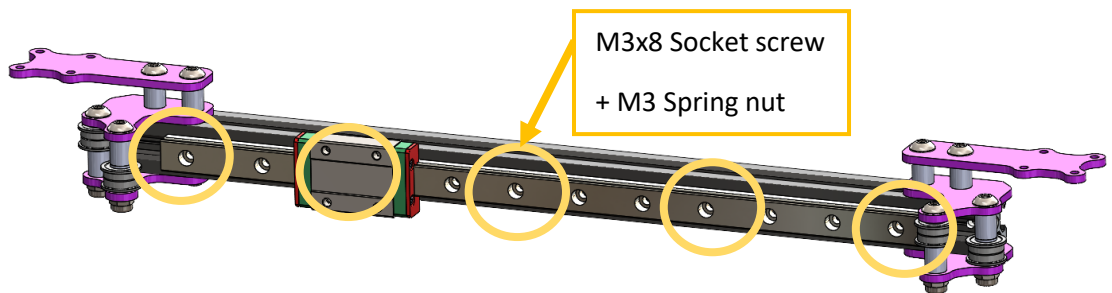
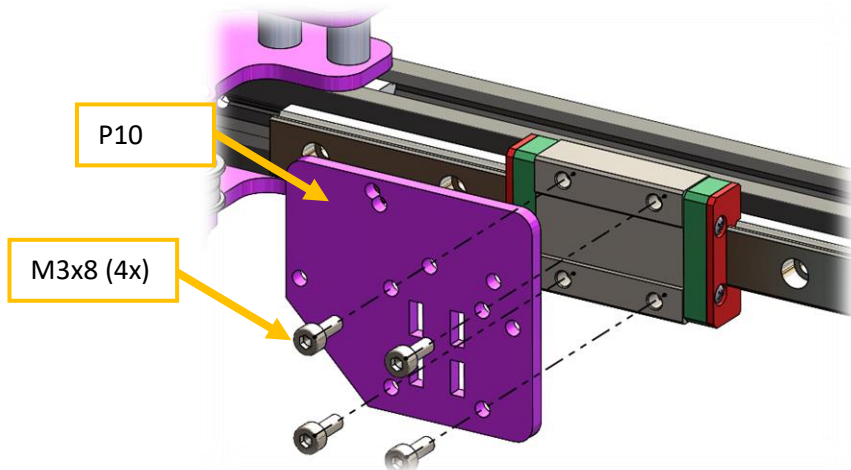

Figure 45 Fix rails with M3x8 Screws + M3 Spring nuts were indicated with circles

- ✓ Install temporarily P10 Bracket for hotend, using M3x8 Socket screws (4x), don't adjust it yet.



Step 4.2 CoreXY system installation

- ✓ Next items from the KIT will be used:

ITEM	ITEM DESCRIPTION	Quantity	Type
1	350 mm Linear rail with slider	2	Kit
2	GT2 Belt tensioner	2	Kit
3	P6 Bracket	2	Kit
4	P9 Bracket	2	Kit
5	Nema 17, 40mm Length motor	2	Kit
6	M5xD8XL8 Spacer	4	Kit
7	M5xD8XL10 Spacer	2	Kit
8	M3xD6XL20 Spacer	6	Kit
9	M5x8x1 Washer	12	Kit
10	M3x25 Screw	2	Kit
11	M3x30 Screw	6	Kit
12	Pulley 20T, Bore 5mm GT2	2	Kit
13	M5x25 Screw	6	Kit
14	M5x30 Screw	2	Kit
15	M4x12 Screw	4	Kit
16	M5 Spring Nut	4	Kit
17	M4 Nylock Nut	4	Kit
18	M5 Nylock Nut	2	Kit
19	F695RS Bearing	12	Kit
20	2GT Pulley 20T	2	Kit
21	2GT 6mm BELT	5 METERS	Kit
22	X axis endstop bracket	1	Printed part
23	M3x8 Socket screw	16	Kit
24	M3 Spring nut	10	Kit
25	M3x10 Socket screw	2	Kit
26	M3x6 Screw	4	Original
27	Y axis endstop bracket	1	Printed part
28	M4x8 Screw	1	Kit
29	M5x8 Screw	2	Kit
30	M4 Spring nut	1	Kit
31	Endstop PCB (X and Y)	2	Original

- ✓ Install Belt tensioners on both sides, using P9 Brackets, M5xD8XL8 Spacers, M5x25 Screws and M5 Spring Nuts as shown:

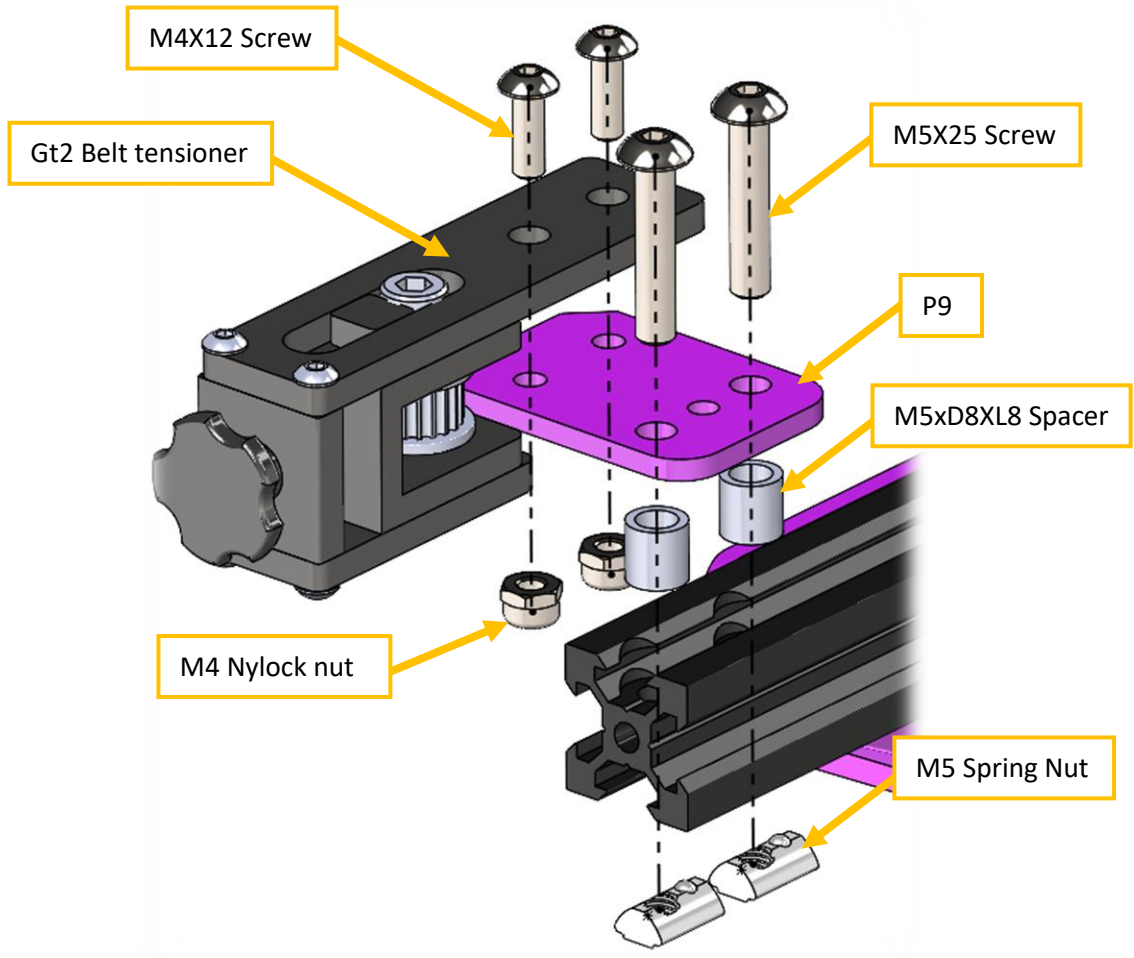

Figure 46 Right side belt tensioner mounting scheme

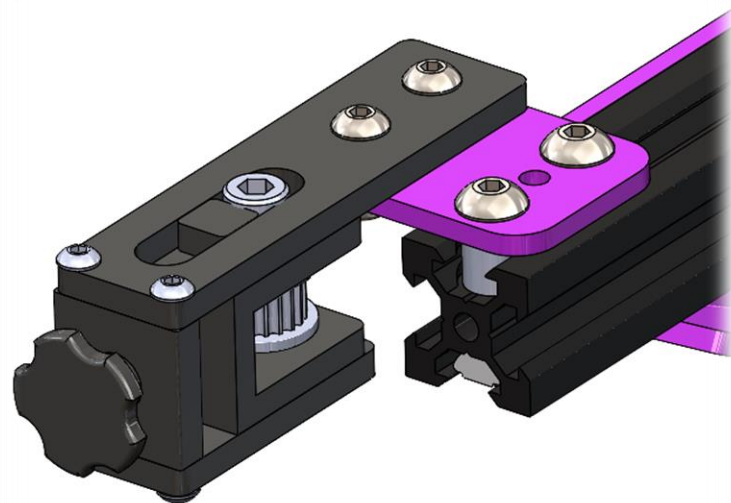

Figure 47 Right tensioner mount

✓ Follow the next scheme for the left side Gt2 Belt tensioner:

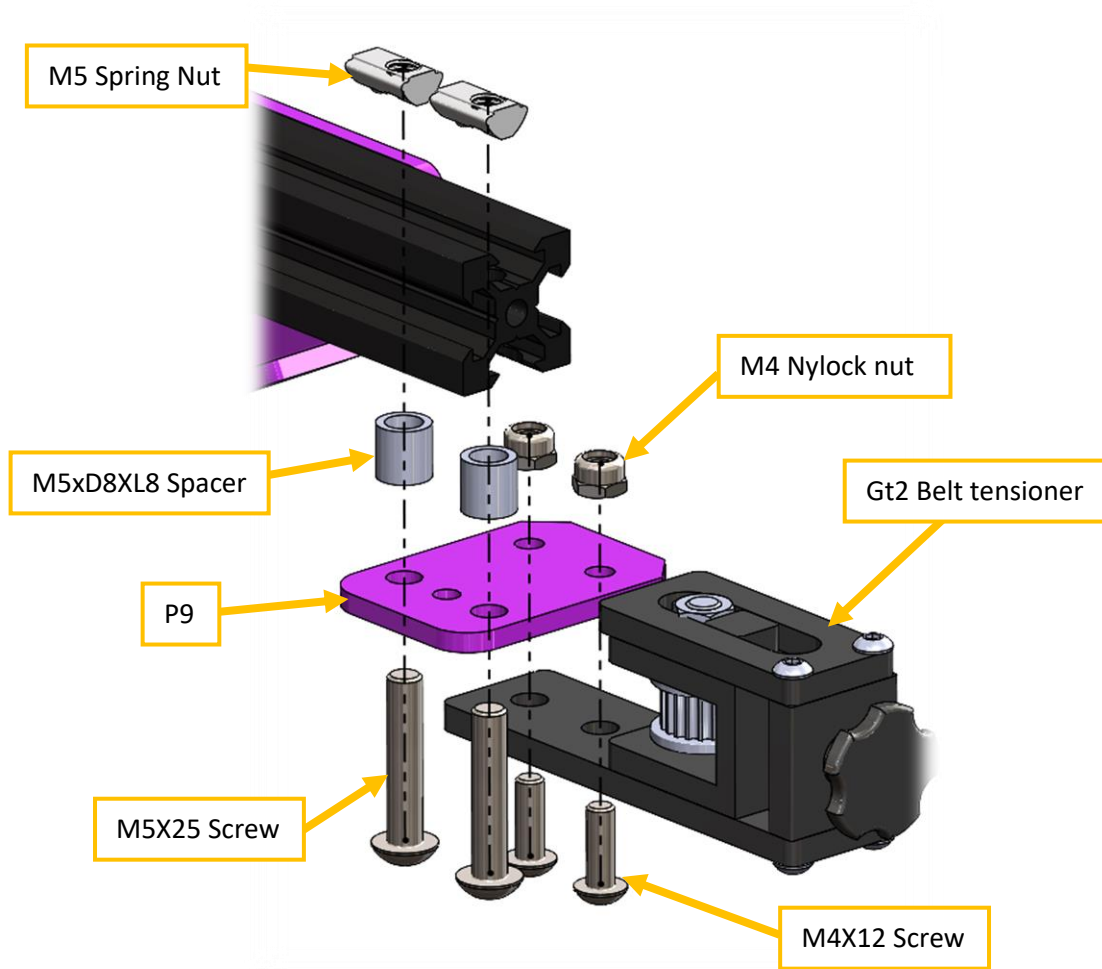

Figure 48 Left side belt tensioner mounting scheme

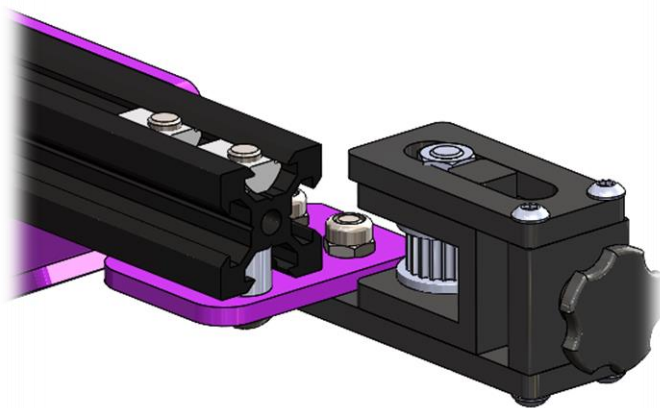

Figure 49 Left tensioner mount

- ✓ Mount the 400 mm Linear rail with slider to the Top frame, using M3x8 Socket Screws and M3 Spring Nuts, Linear rail must be centered with the X aluminum extrusion:

NOTE: Be very careful when installing slider part of the rail, don't drop any ball, it might result in a damaged rail if 1 or 2 balls were dropped:

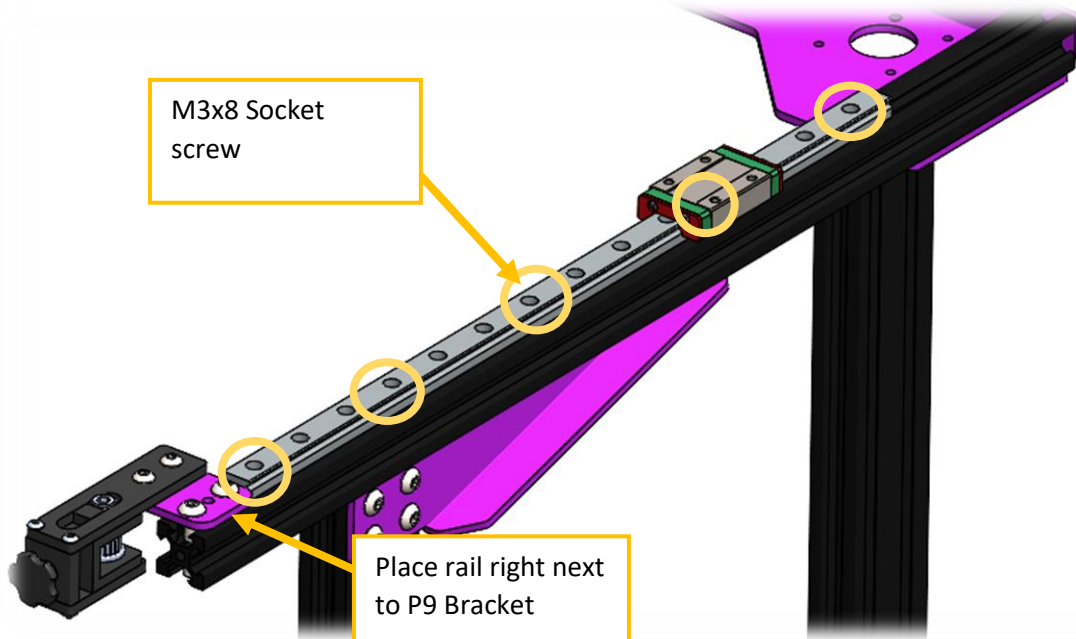

Figure 50 Right side, Fix rail with M3x8 Screws + M3 Spring nuts were indicated with circles

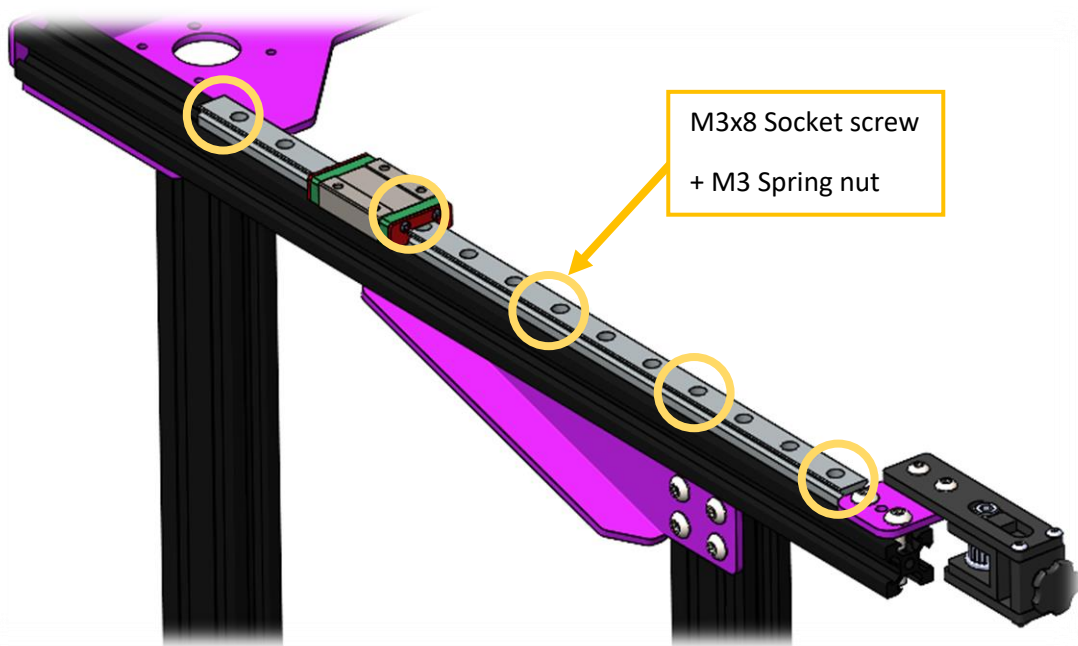

Figure 51 Left side, Fix rails with M3x8 Screws + M3 Spring nuts were indicated with circles

- ✓ Before mounting X axis, let's install the back components of the CoreXY system, P6 brackets, M3xD6XL20 Spacers, Nema 17 motors, Gt2 Pulley:

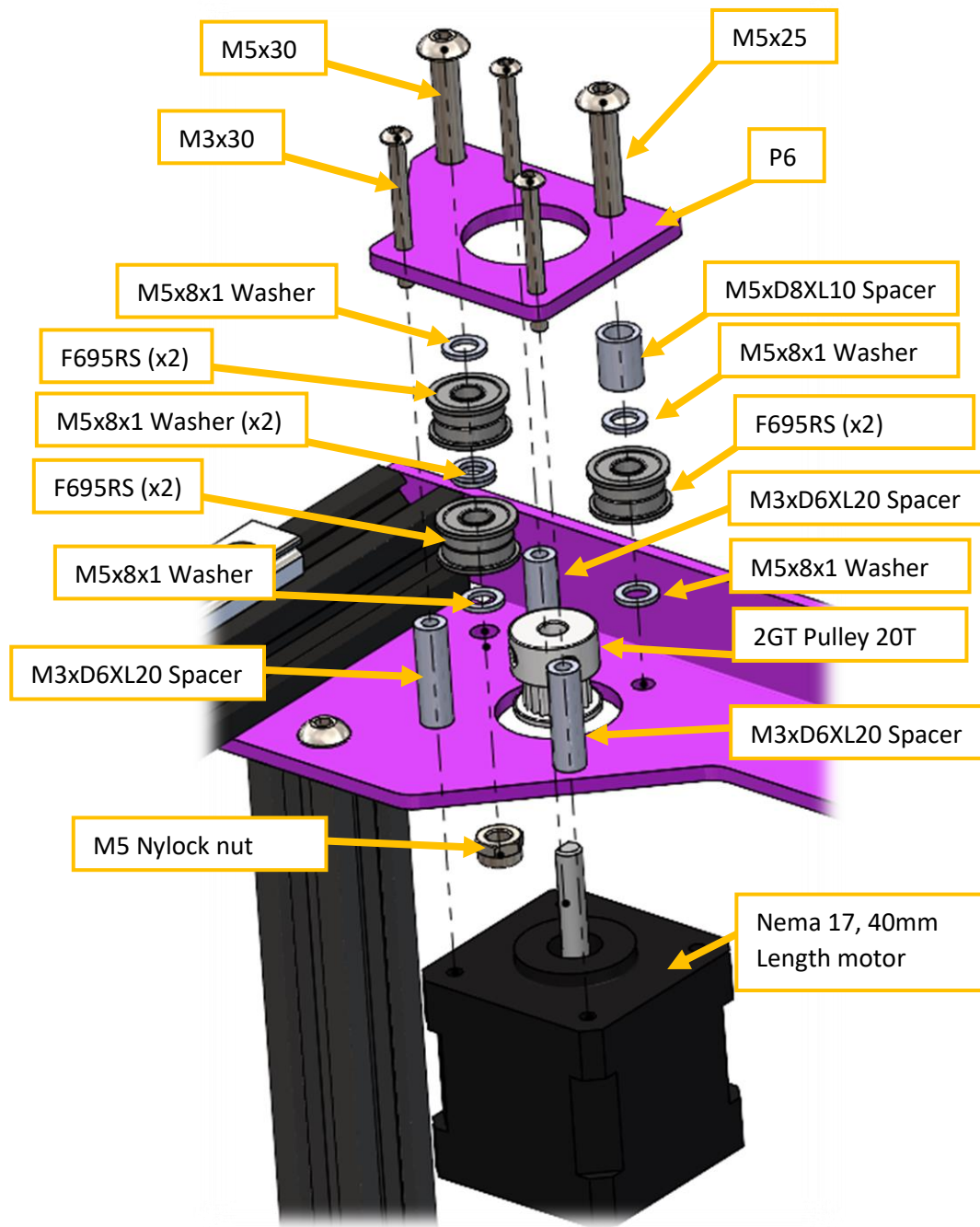

Figure 52 Left side Nema + Pulleys mount scheme

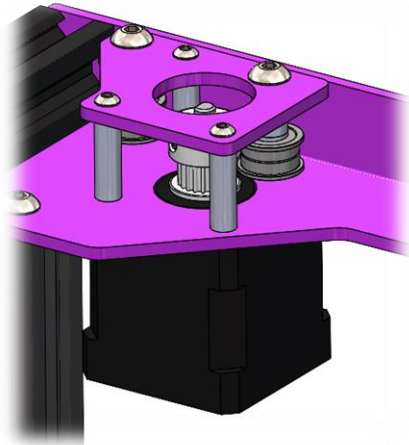

Figure 53 Left side motor mount finished

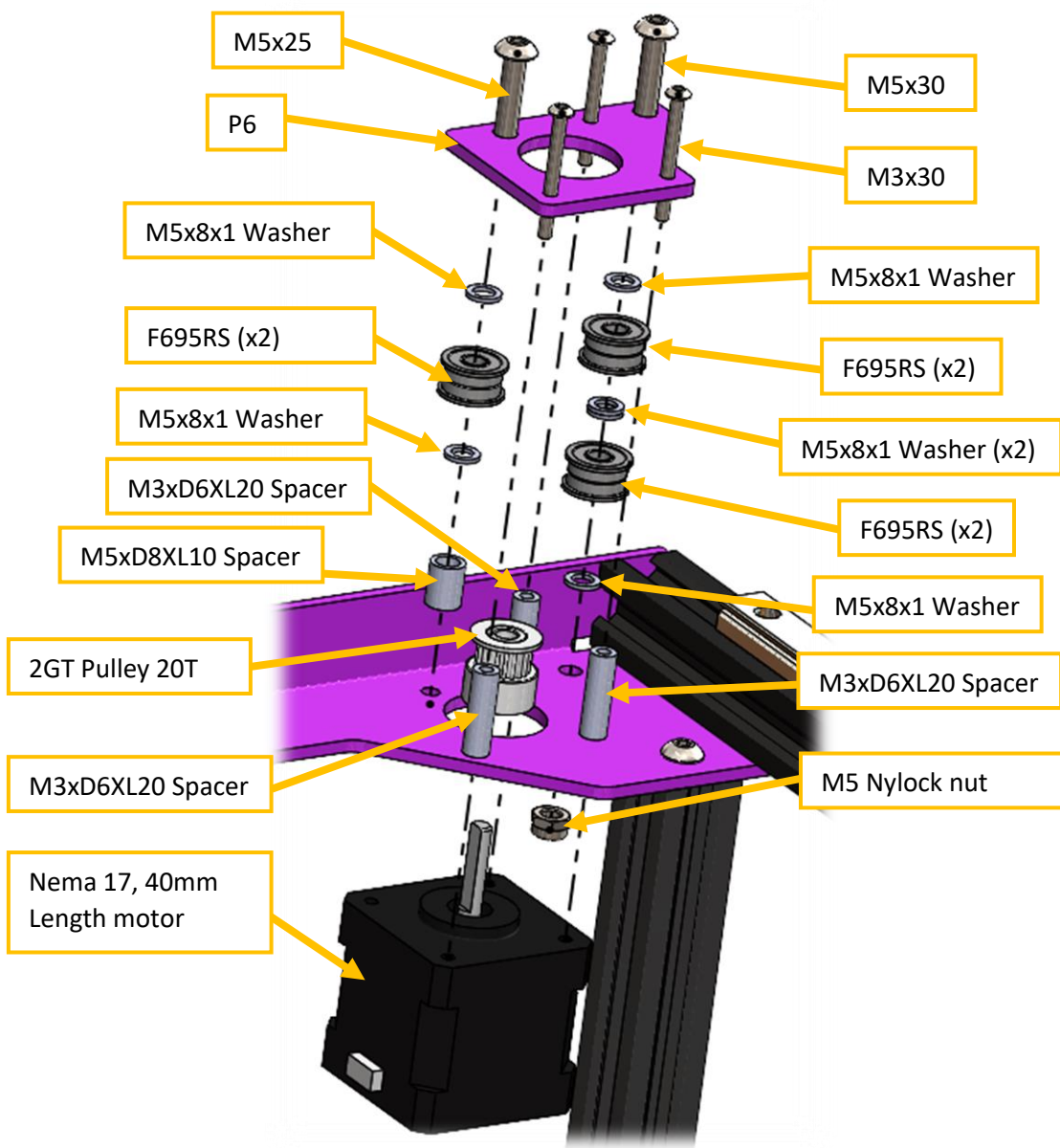

Figure 54 Right side Nema + Pulleys mount scheme

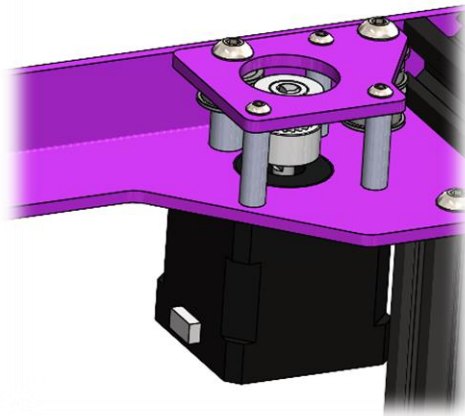

Figure 55 Right side motor mount finished

- ✓ Mount previous X axis assembly, using M3x8 Socket screws on both sides, at this point we will also install the X endstop bracket using M3x10 Socket screws, also it's a good time to mount the X endstop, fixed with M3x6 screws:

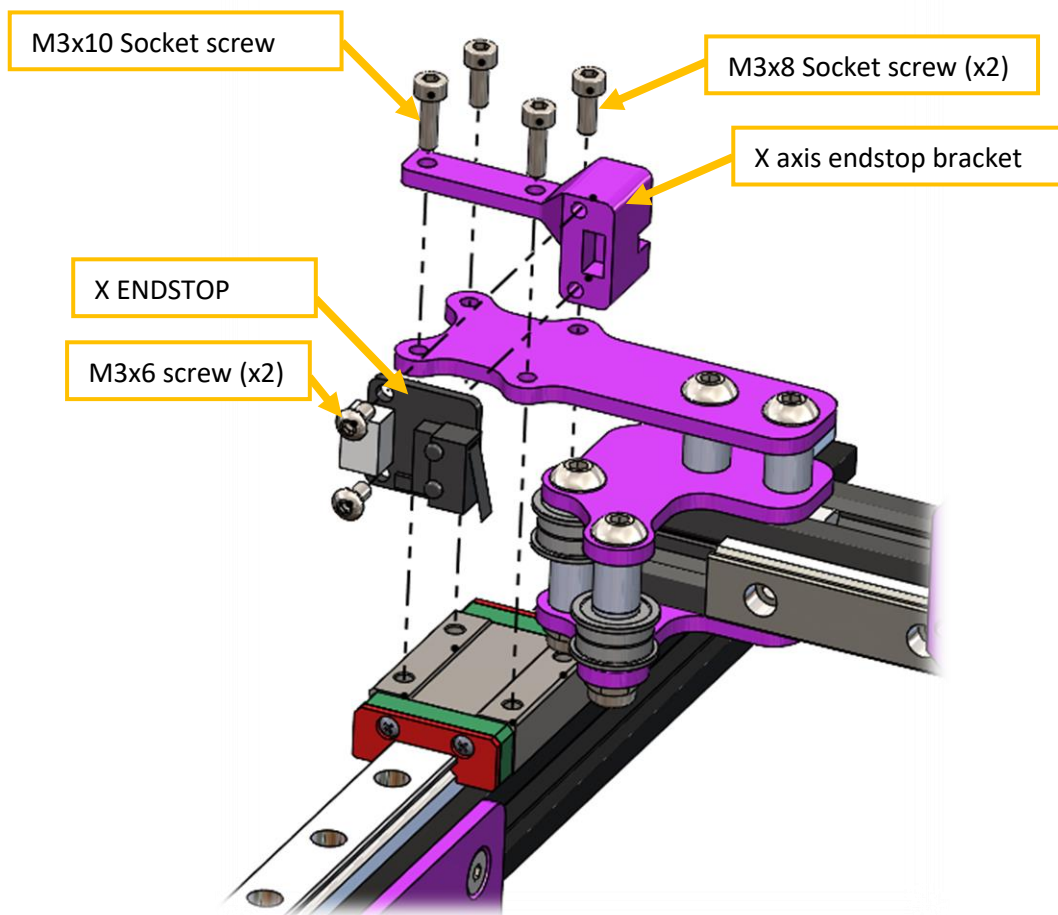

Figure 56 Left side X axis mount scheme

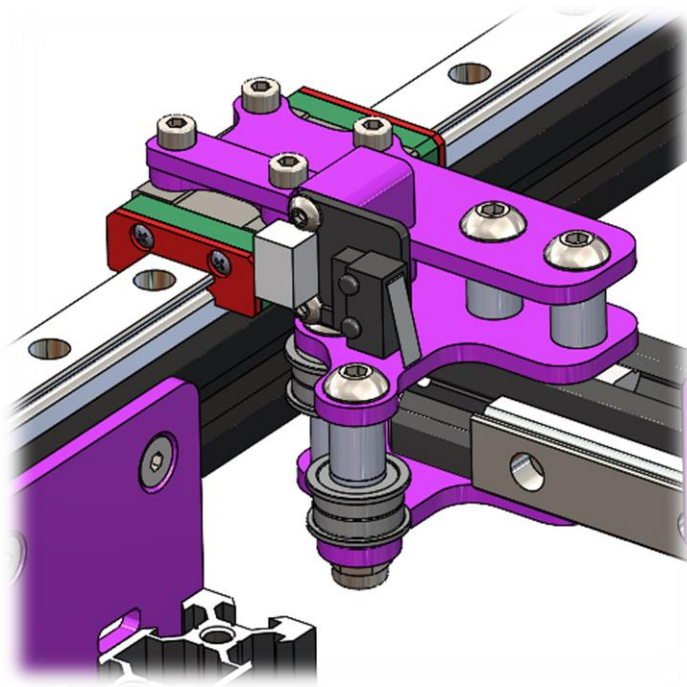

Figure 57 Left side detail of X mounting

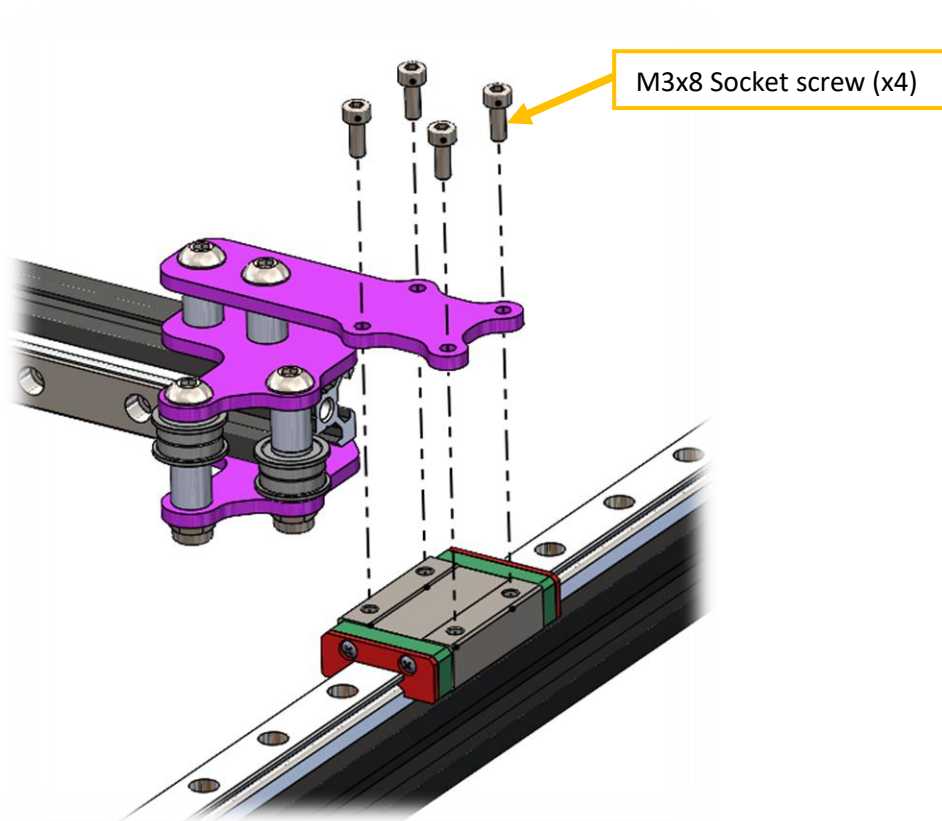

Figure 58 Right side X axis mount scheme

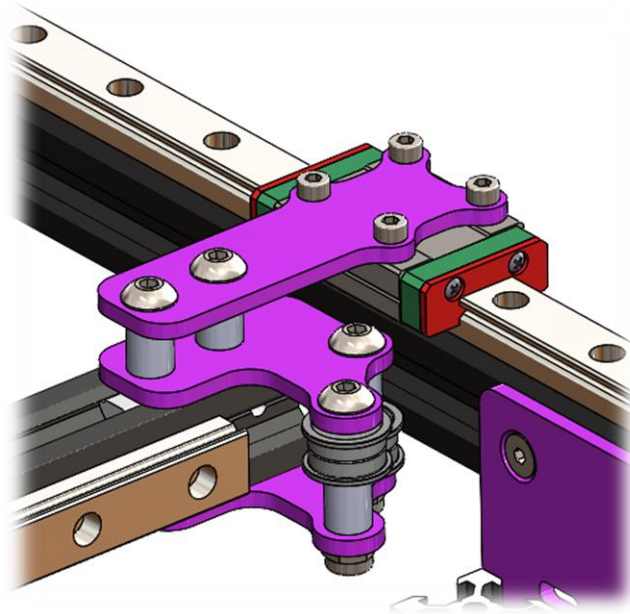

Figure 59 Right side detail of X mounting

- ✓ Install Y endstop bracket using M4x8 Screw and M4 Spring nut on the front left side of the top frame, also mount Y endstop, fixed with M3x6 screws:

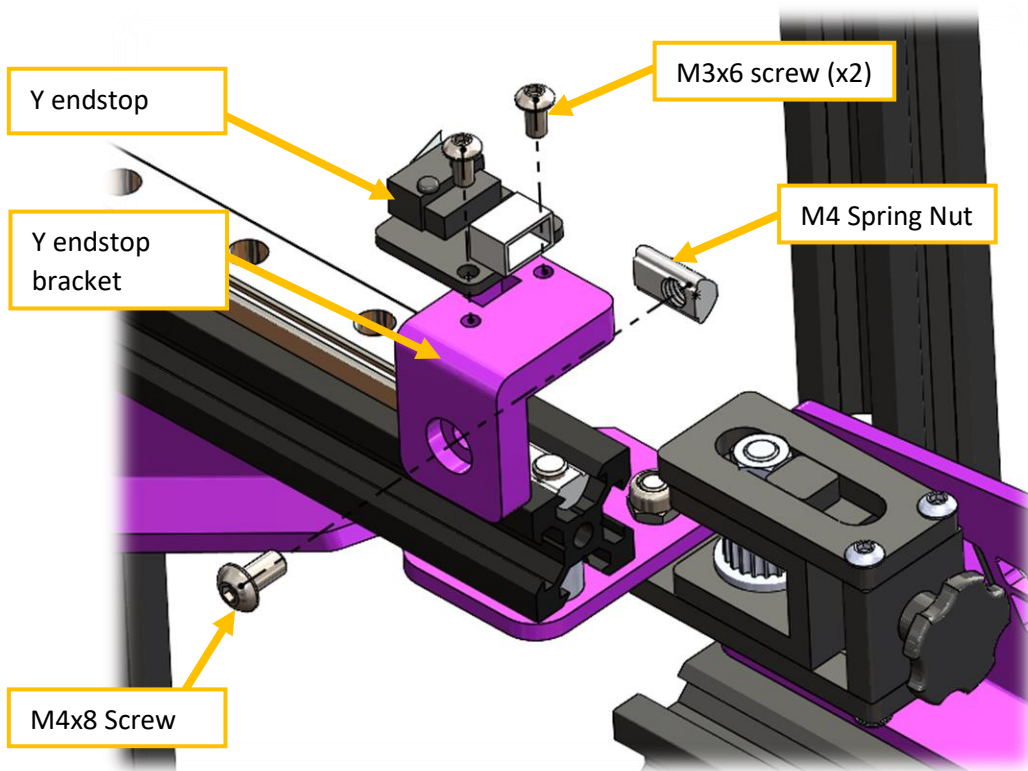

Figure 60 Y endstop mounting scheme

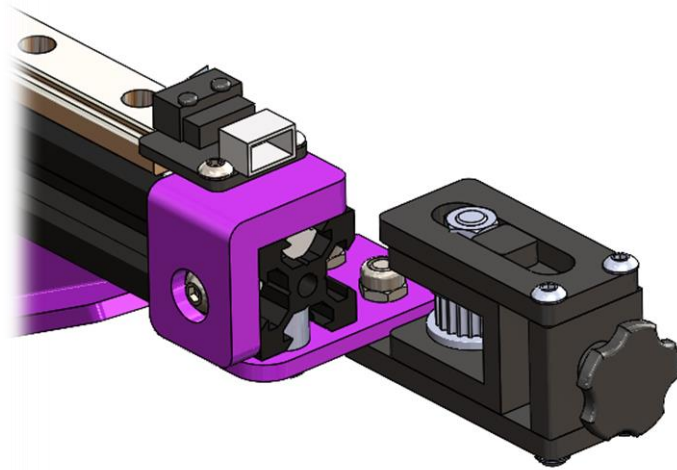

Figure 61 Y endstop mounting detail

- ✓ Install Gt2 Belt for the CoreXY system:

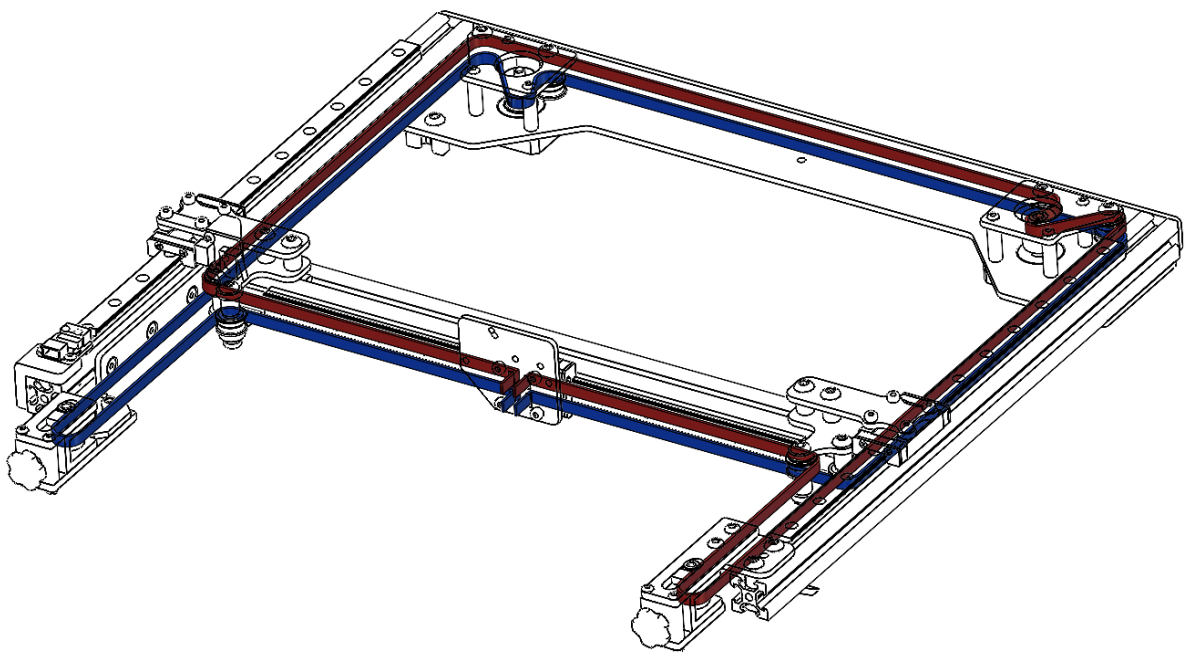

Figure 62 Belt Scheme, Blue: motor A, Red: motor B

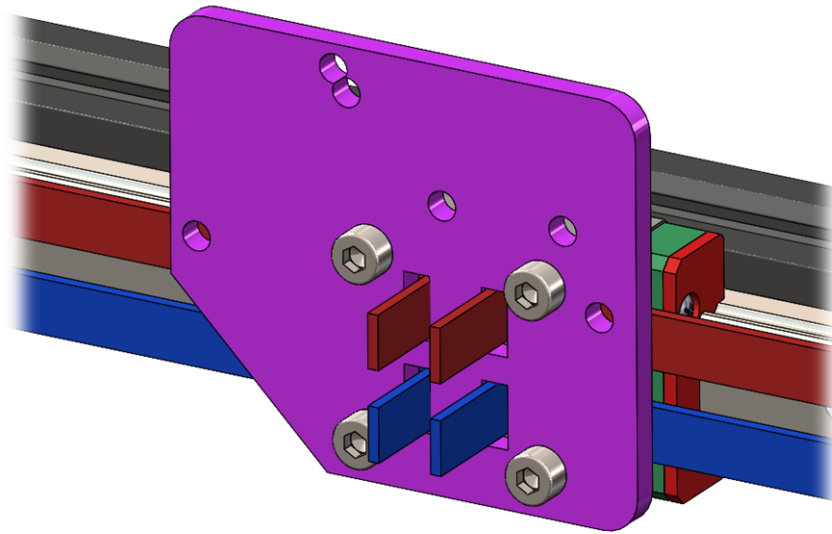

Figure 63 Secure belts using P10 bracket, adjust M3x8 Screws

- ✓ Using both belt tensioners, properly tension belts evenly:

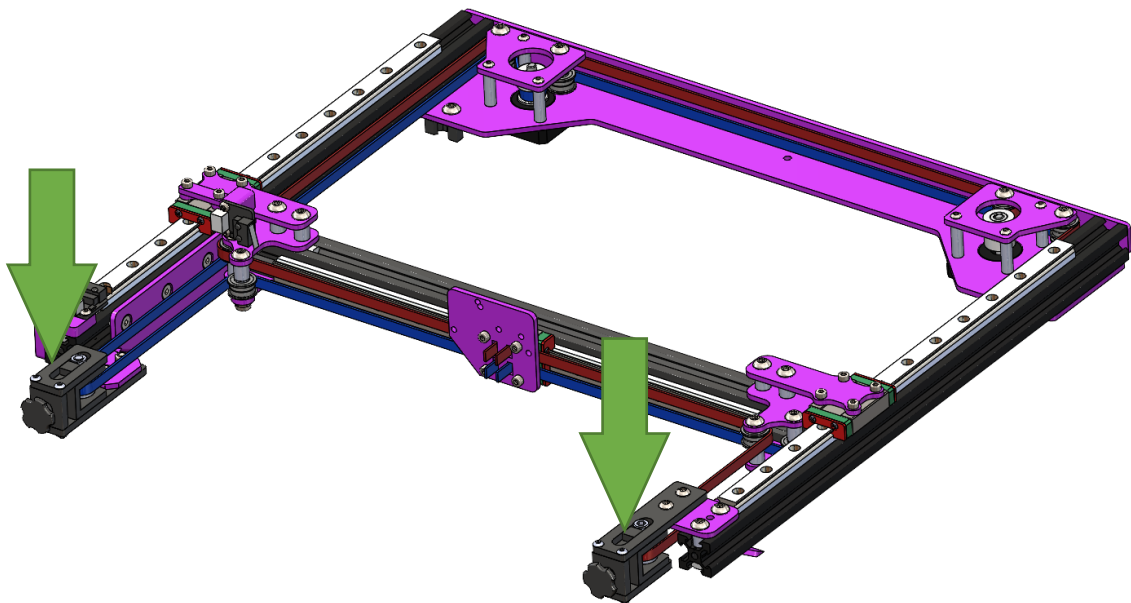

Figure 64 Using belt tensioners

Step 4.3 Hotend mount

This step depends on the actual Hotend / extruder setup you're using, we will cover the stock Hotend/extruder of Cr-10/ V2 and V3.

- ✓ Cr-10 versions:

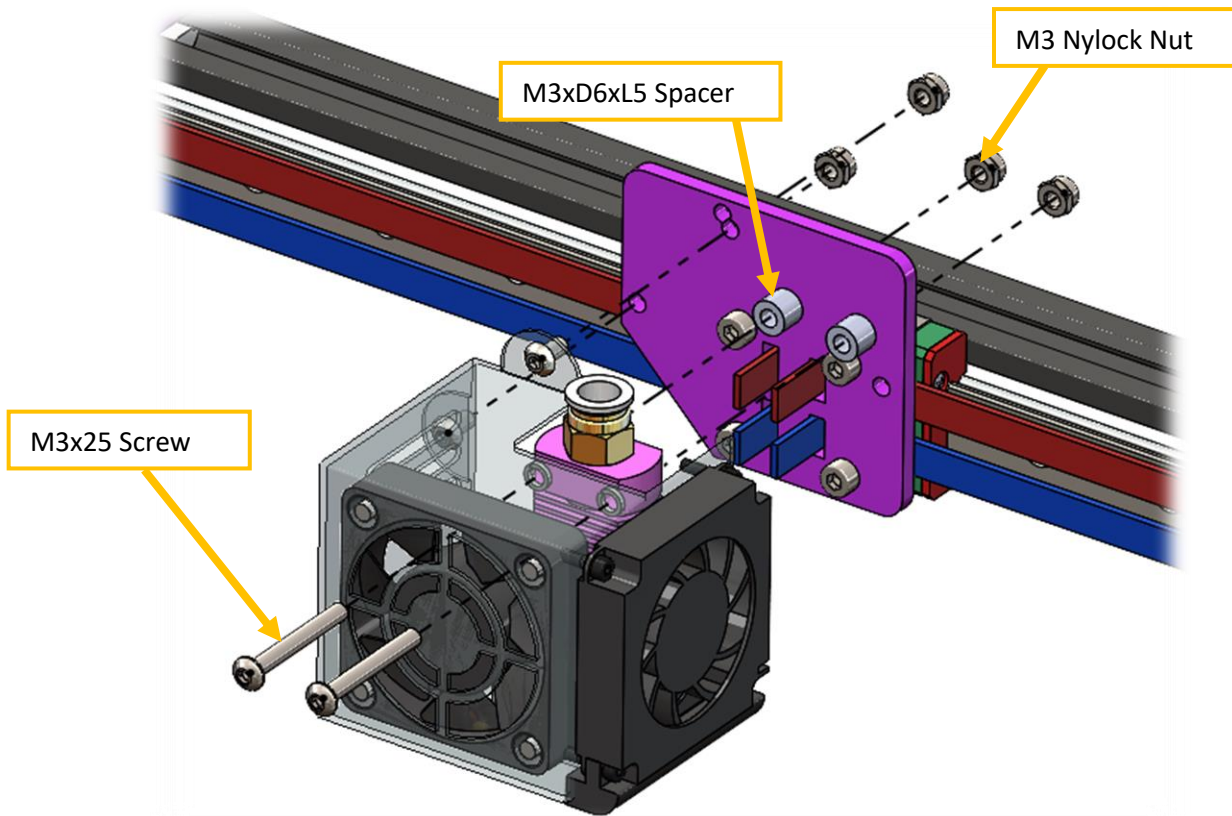

Figure 65 Stock Hotend Cr-10/PRO mounting scheme

- ✓ Stock extruder mount, using supplied Nema17 metal bracket, and 2 units M5x8 Screws + M5 Spring nut:

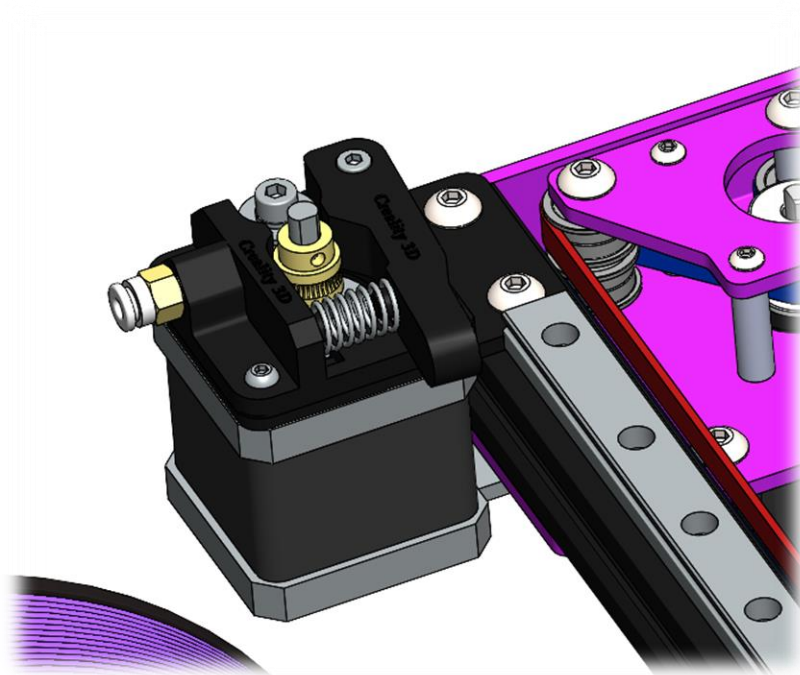

Figure 66 Suggested extruder position

Chapter 5 Installing Heatbed and Z axis

Step 5.1 Heatbed bracket

- ✓ Next items from the KIT will be used:

ITEM	ITEM DESCRIPTION	Quantity	Type
1	Flat corner bracket	4	Kit
2	1020 ALU PROFILE 350mm	1	Kit
3	1020 ALU PROFILE 220mm	2	Kit
4	1020 ALU PROFILE 280mm	1	Kit
5	M5x8 mm SCREW	16	Kit
6	M5 Spring nut	16	Kit

- ✓ Preparing Heatbed base plate:

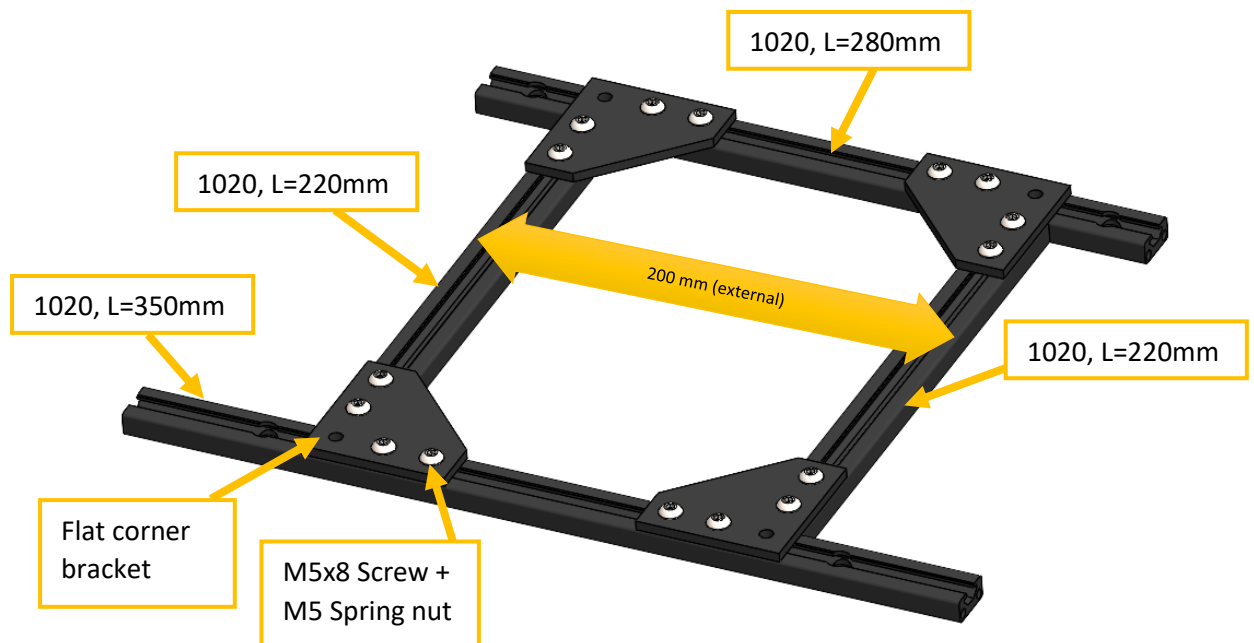

Figure 67 Heatbed base plate.

Step 5.2 Installing Z axis elements + Heatbed

- ✓ Next items from the KIT will be used:

ITEM	ITEM DESCRIPTION	Quantity	Type
1	Heatbed Assembly	1	-
2	Z motor Mount block	3	Kit
3	Nema 17 motor L=34mm	3	1 from Kit, 1 from Original parts
4	Z motor coupler	3	1 from Kit, 2 from Original parts
5	450 mm Linear rail with slider	3	Kit
6	T8 Leadscrew, L=460mm	3	Kit

7	M3x8 mm Socket screw	16	Kit
8	M5x8 mm SCREW	2	Kit
9	M3 Spring nut	10	Kit
10	M5 Spring nut	2	Kit
11	T8 Brass nut	2	1 from Kit, 1 from Original parts
12	M3x6 Screw	2	Kit
13	M3x10 Socket Screw	2	Kit
14	M3x25 Socket Screw	1	Kit
15	M4x16 Flat Screw	4	Kit
16	M4 Spring Nut	4	Kit
17	Z axis endstop bracket	1	Printed part
18	Z Limit bracket	1	Printed part
19	Endstop PCB (Z)	1	Original

- ✓ Mount the 450 mm Linear rail with slider for the Z axis, using 05 units M3x8 Socket Screws and M3 Spring Nuts for each side, Linear rail must be centered with the X aluminum extrusion:
NOTE: Be very careful when installing slider part of the rail, don't drop any ball, it might result in a damaged rail if 1 or 2 balls were dropped, temporarily secure sliders with blue tape or similar:

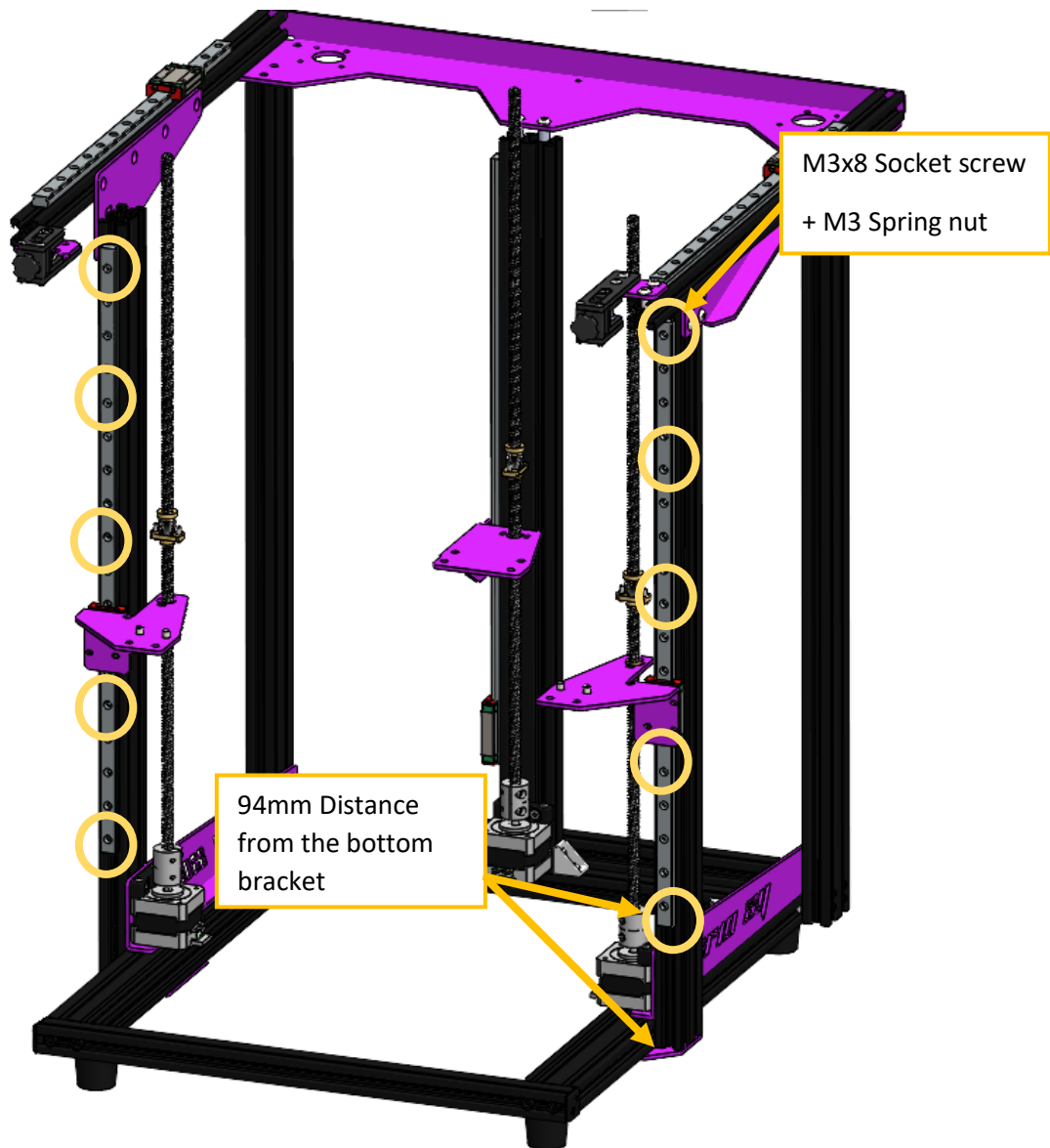

Figure 68 Z rails mounting

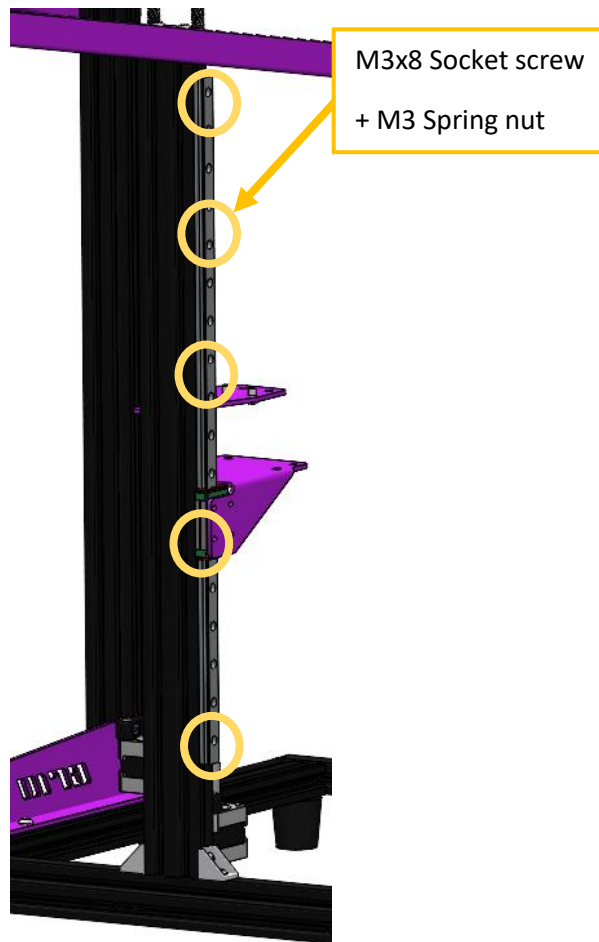

Figure 69 Z rails mounting, 3rd rail is mounted at the left side of the 2040 extrusion

- ✓ Mount Z motors as shown, repeat process on both sides and to the back:

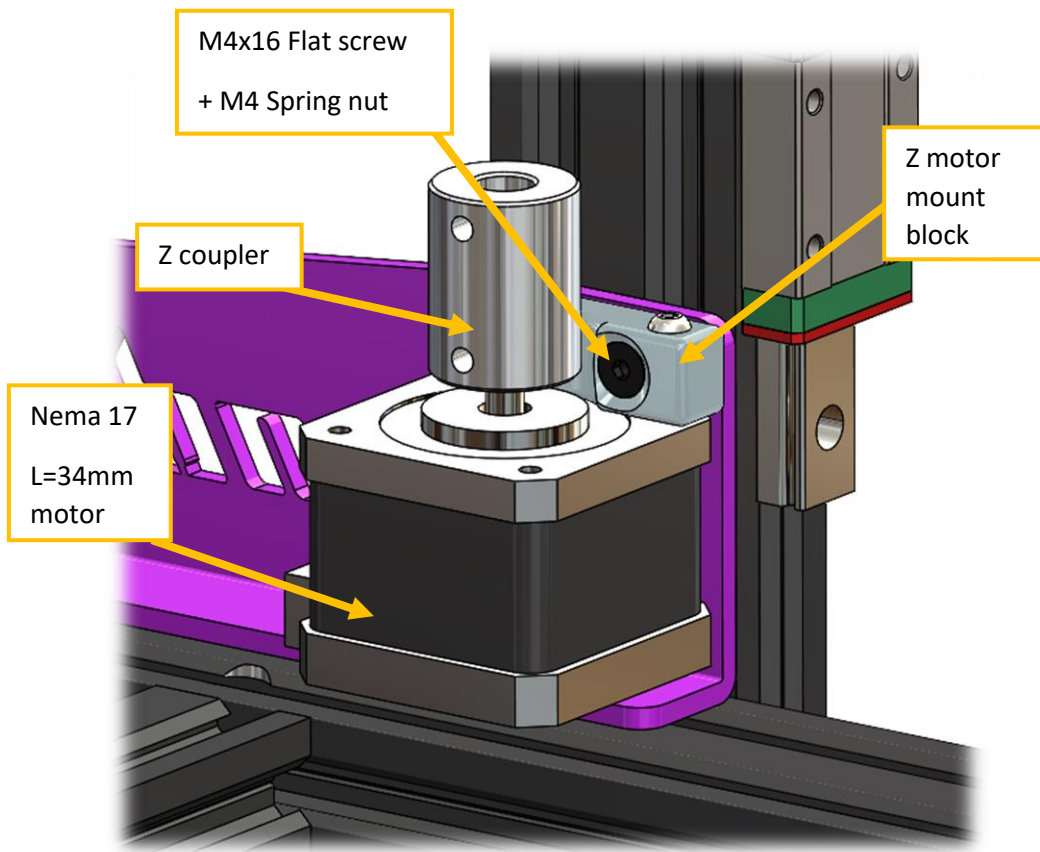

Figure 70 Z motor mount detail

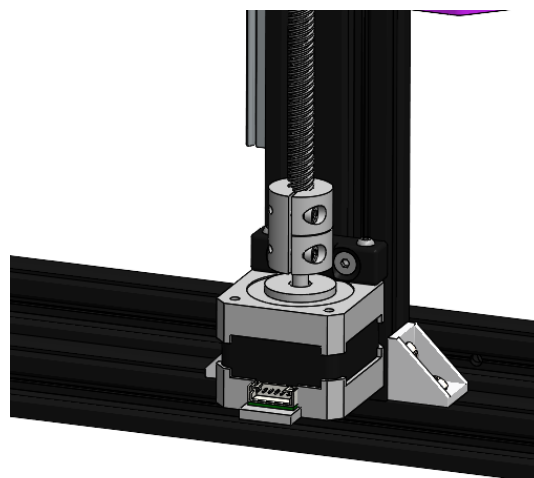
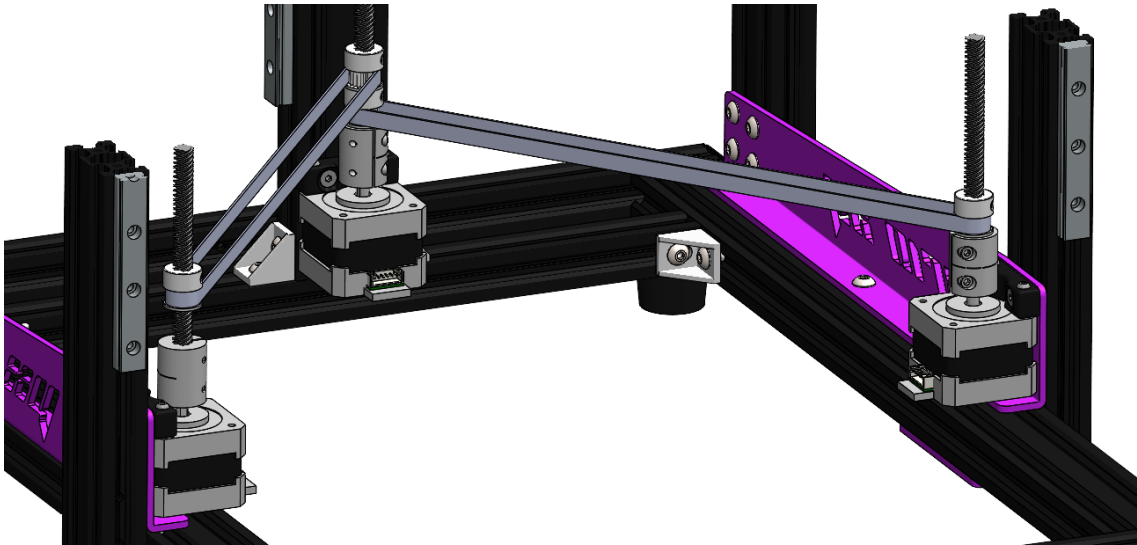

Figure 71 Z motor mount detail (3rd Z leadscrew)

- ✓ Install Gt2 20T bore 8mm pulleys as shown, and closed belts:



- ✓ Install heated bed brackets supports and fix to linear rails sliders on both sides, also install Z limit bracket as shown, then install supplied T8 Leadscrews L=460mm on both sides and one in the back:

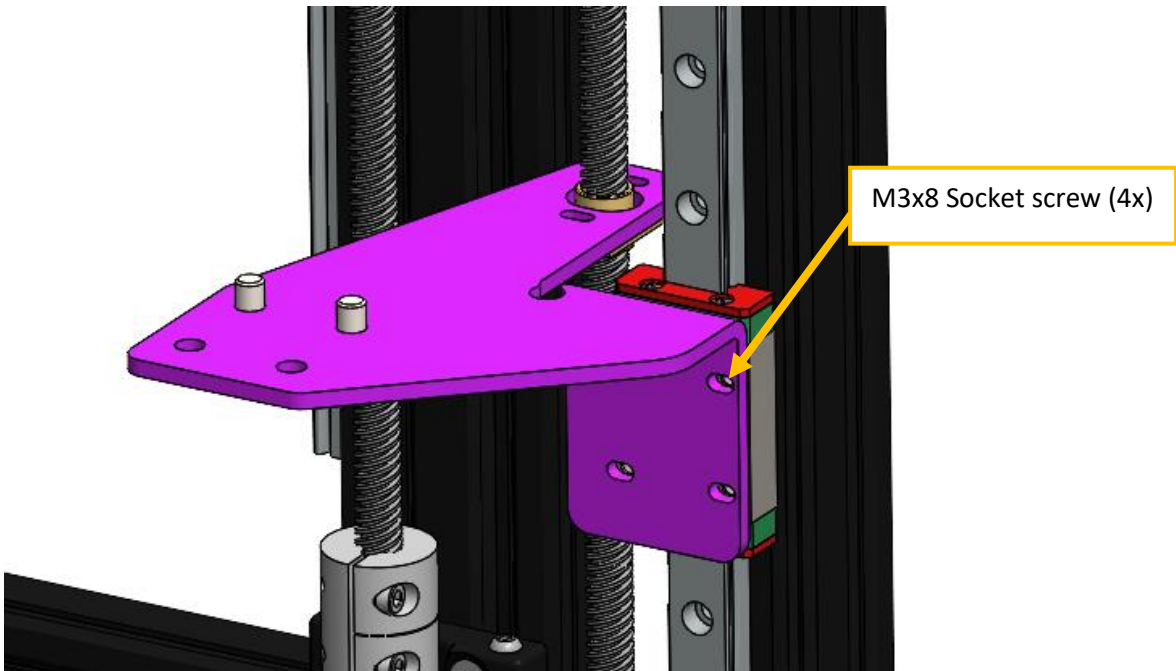

Figure 72 Right side detail

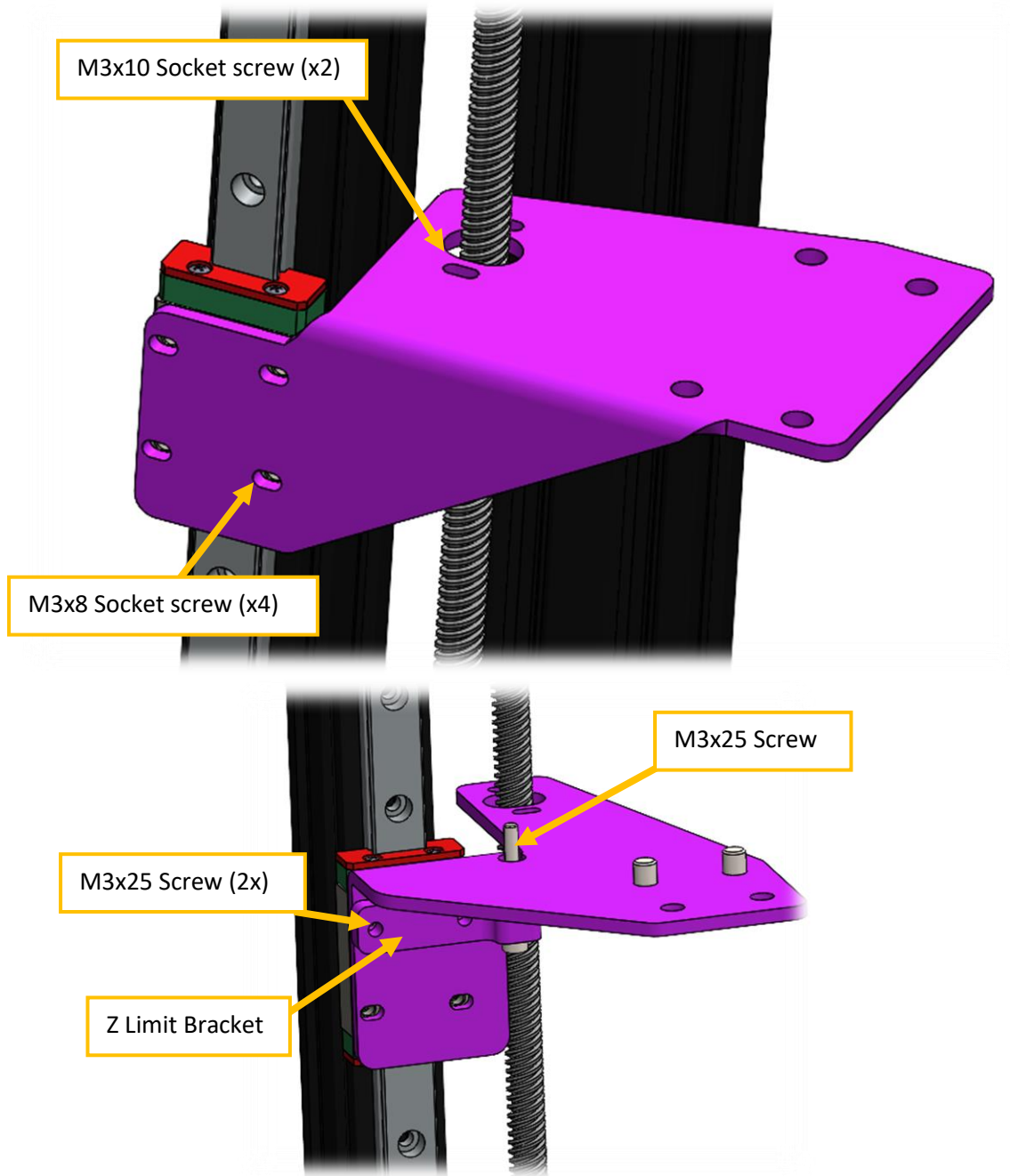

Figure 73 Left side detail

- ✓ Install heatedbed frame over the brackets as shown, notice it will be installed upside down and fixed from the underside, :

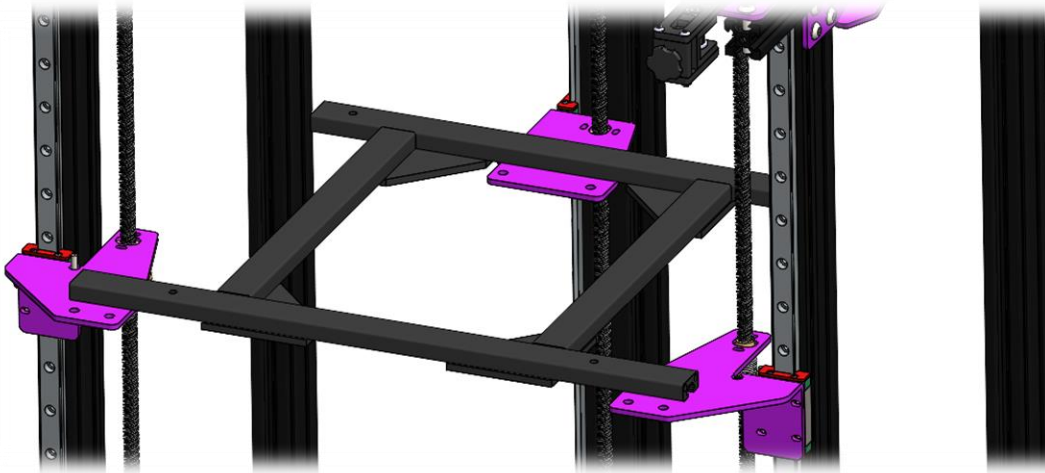

Figure 74 Top view for the bed bracket assembly



Figure 75 Underside view for the heatbed frame assembly

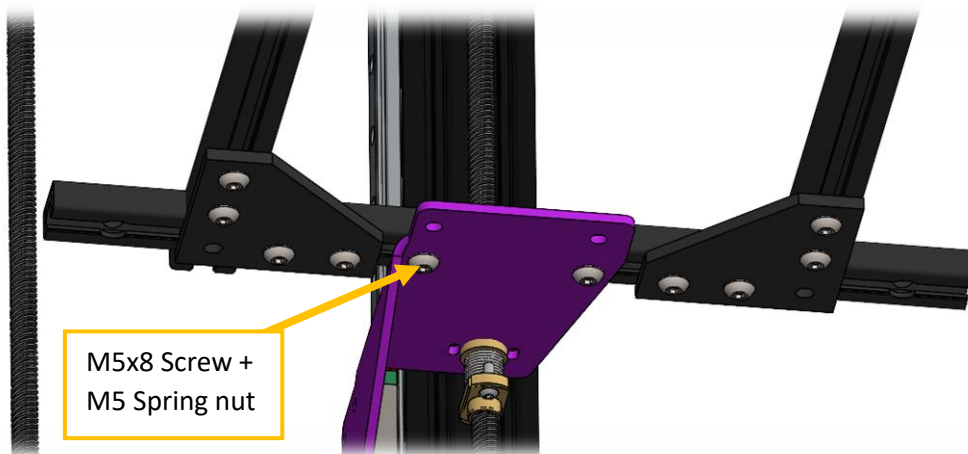
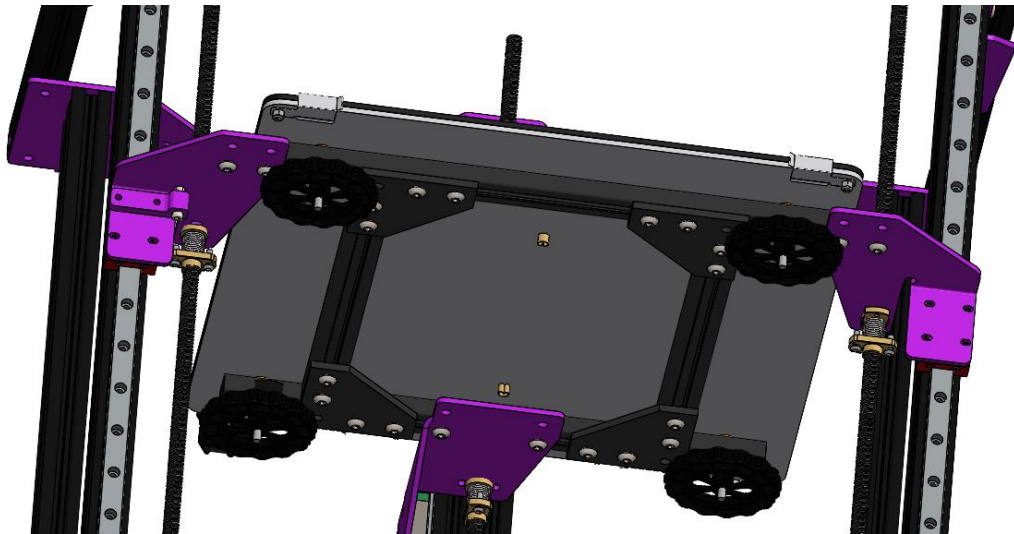

Figure 76 Underside view for the heatbed frame assembly



Figure 77 Underside view for the heatbed frame assembly

- ✓ Install heatbed assembly over the heatbed frame, leveling screws and springs must fit with the 4 holes, then install the plastic leveling nuts as shown:



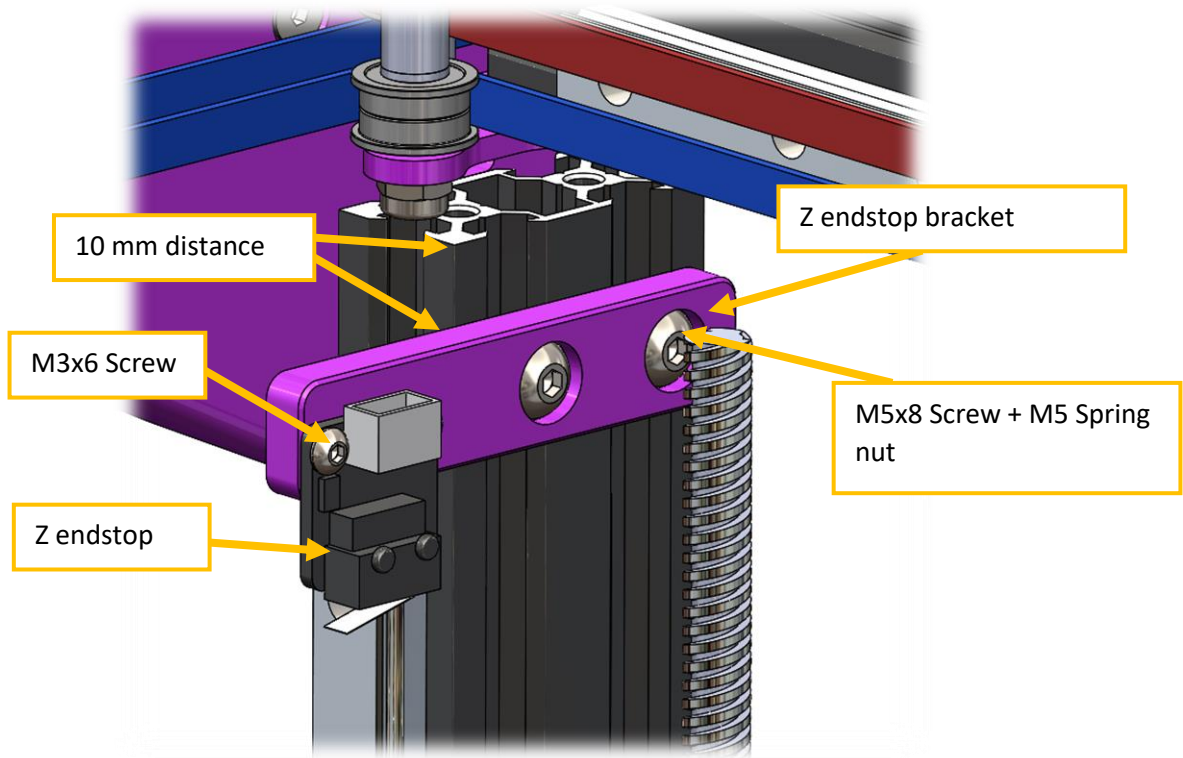

Chapter 6 Electronics and firmware

Step 6.1 Electronics

Wiring Scheme:

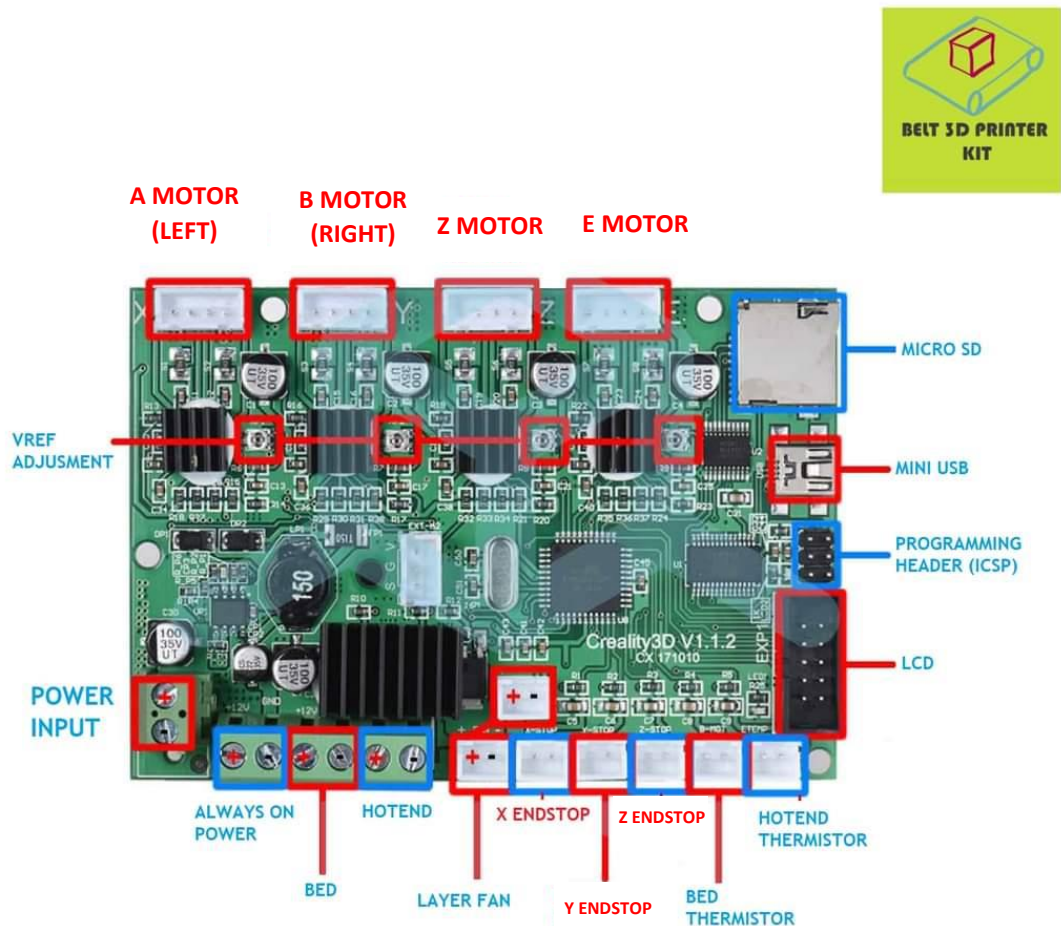

Figure 78 Wiring scheme for each component

- ✓ Connect all cables back to the motherboard, for stepper motors, use supplied 1-meter cable motors, instead of original ones:



- ✓ For X and Y axis endstops use supplied custom cable, since original one will be too short.



- ✓ Use supplied Zip ties for cable management

Step 6.2 Firmware

- ✓ Firmware will be provided for updating, there are a few methods out there to upgrade your Cr-10 firmware, but we recommend checking out Teaching Tech method:
<https://youtu.be/fil5X2ffdyo>