



GOTRAX

GKS Plus

KIDS ELECTRIC SCOOTER

USER MANUAL

Congratulations on your purchase!



GOTRAX

This user manual will help you assemble and operate your new Electric Scooter. Be sure to read **ALL OF THE INFORMATION** in this manual before riding.

NOTE TO ALL RIDERS UNDER 12 YEARS OR AGE:

It's very important that you get parental permission before riding your electric scooter. Electric scooter for kids age of 6-12.





Don't ride until you read this



ALWAYS wear a helmet when riding your Electric Scooter.



Make sure your scooter has a **full battery** before taking it out to ride.



Always be aware of local road laws, and follow them.



Do not ride the scooter under the influence of drugs or alcohol.



Always respect pedestrians.



Do not ride under wet conditions. The scooter may slide from under your feet causing injury. Wet conditions may damage the electronics and void the warranty.



Warning Message

1. **Avoid water** - The scooter is not waterproof. The electronics may be damaged due to water and water damage is not covered by our warranty. Riding in wet conditions is also very dangerous and may result in injury.
2. **Abuse** - We do not cover physical damage due to negligent care and extreme riding.
3. **Whenever you ride the GOTRAX scooter**, you risk severe injury or even death from loss of control, collisions, and falls. Use caution and ride at your own risk.
4. **Do not** modify the product from the manufacturer's original design.
5. **Keep** hands and all body parts away from moving parts while operating the scooter.
6. **Before riding** - be sure to check the scooter over and make sure the scooter is operating correctly before each use.
7. **Before riding** - be sure to check that the braking system is functioning properly; also be sure to check that all safety labels are in place and you understand the safety warnings.
8. **Before riding** - be sure that any and all axle guards, chain guards, or other covers or guards supplied by the manufacturer are in place and in serviceable condition.
9. **Before riding** - be sure to check that the tires are in good condition, inflated properly, and have sufficient tread remaining.
10. The electric scooter should be used by children between the age of 6-12.
11. **Maximum Speed** - Your electric scooter goes the maximum speed of 7.5 mph.



Unpack

You should find each of these items in your box:

1. Scooter Front & Rear Wheel Compartment & Screws cover
2. Handlebar
3. Approved Power Adapter/ Charging Unit
4. 4mm Allen wrench
5. 6mm Allen wrench
6. 4 Screws

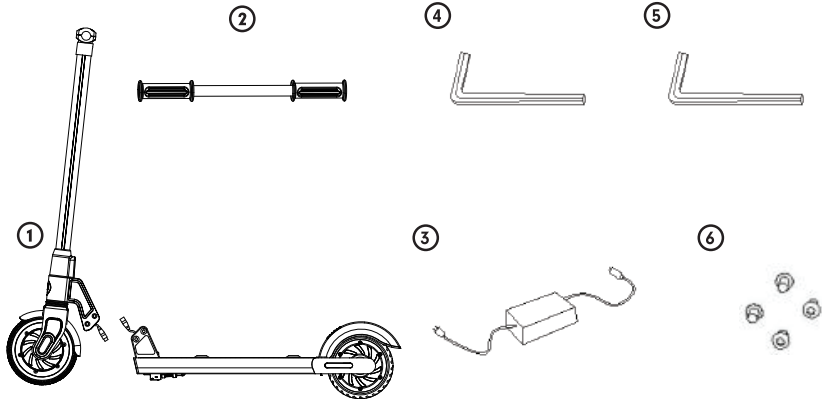

Remove all packaging material, then inspect each item for any accidental damage that may have occurred during shipping.



Get To Know Your Scooter

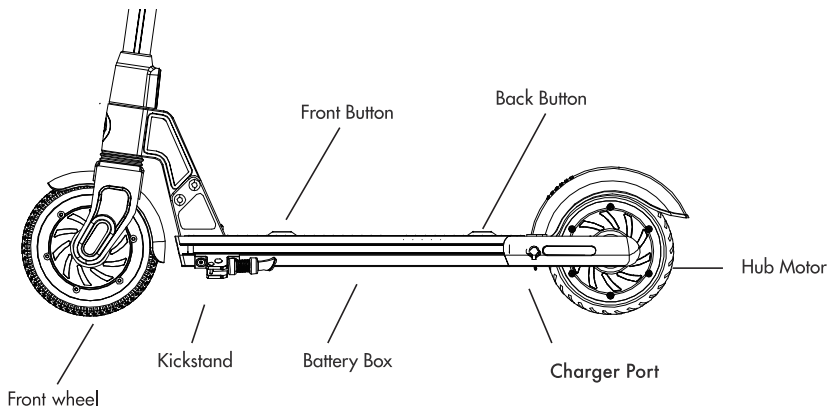

The electric scooter comes partially assembled.

Specifications

Top Speed:	7.5 mph
Distance per Charge:	7 miles
Max Weight:	154 lbs
Battery Type:	25.2V 2.6Ah
Battery Input:	DC 29.4V 0.6A
Charging Time:	5 hours
Motor Power:	150W
Power Requirements:	AC100V ~ 240V 50/60Hz



Assemble Your Scooter

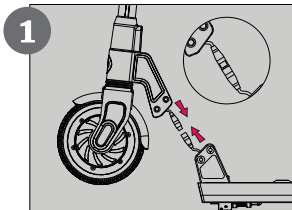

CONNECT THE POWER CORDS

Connect the power supply cords of the front luminous wheel together.

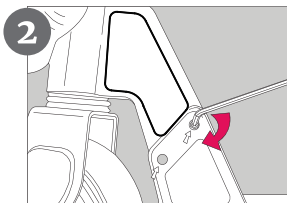

ASSEMBLE FRONT AND REAR WHEEL COMPARTMENTS

Assemble the front wheel compartment and rear wheel compartment together, Take the 4 screws and use the 6mm Allen Wrench to tighten the screws. Once the screws are tightened, open the kickstand and straighten the scooter out.

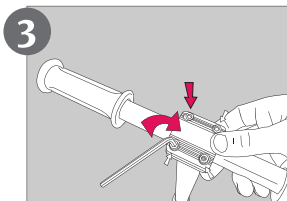

REMOVE SCREW FROM BLOCK ON TOP OF THE TILLER

Use 4mm Allen wrench to remove the screws from the block on the top of the tiller, put the handlebar on and cover with the top of the block. Tighten the screws. Test the scooter after you've finished assembling.



Charge Your Scooter

Before using the scooter, you must fully charge the battery.

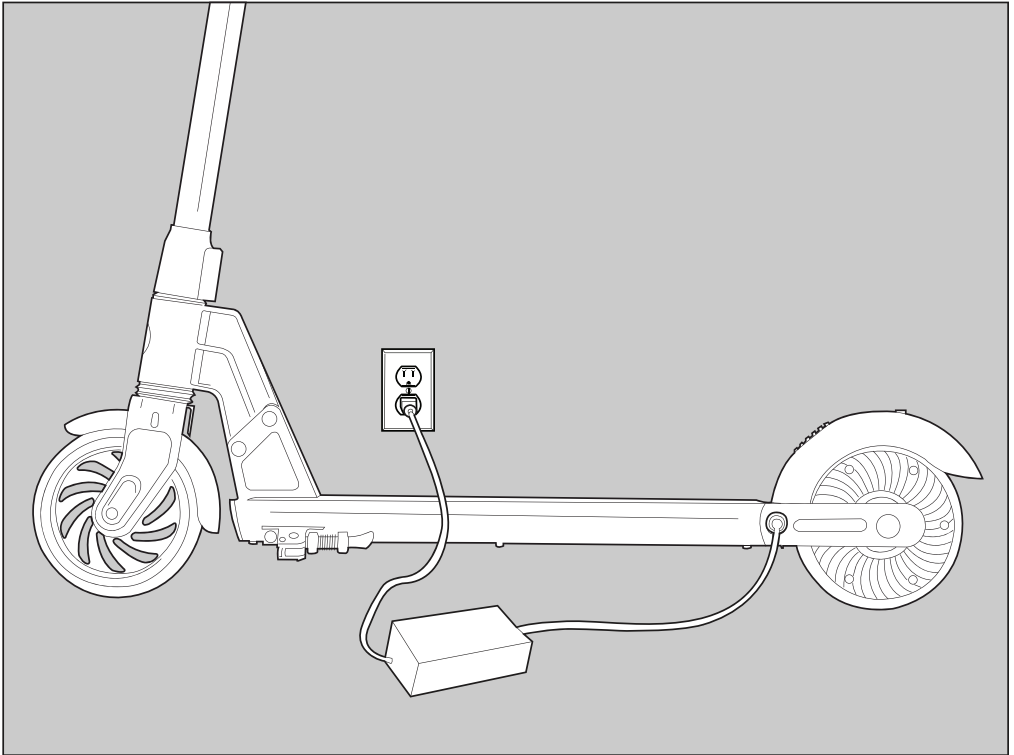

1. Open the rubber charging port cover.
2. Insert the charging plug into the port.
3. The charger box will have a green light when fully charged and a red light when charging.
4. When you are done charging be sure to cover the charging port to keep it clear of dust and debris.
5. Charging Time: 5 hours

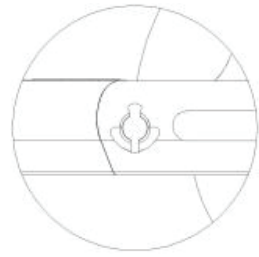
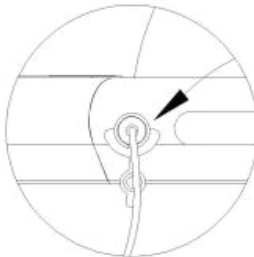
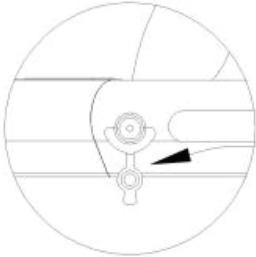



Scooter Console Functions

To power the scooter on , you must place your foot on the front button and kick to start.

To accelerate the scooter , you must place your first foot on the front button and kick to start. Once you have the scooter moving then place your second foot on the back button to engage the electric motor to accelerate. (Caution: While riding the scooter if you don't wish to accelerate any more remove your foot from the back button and the motor will turn off).

To brake , remove your back foot from the back button and place your foot on the rear fender brake to slow down or stop.

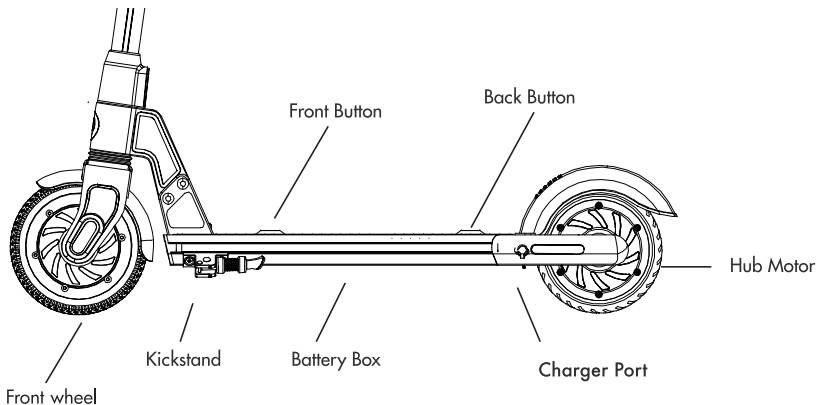



Riding Tips

1. You will want to start riding your scooter with one foot on the front button and one foot on the ground. Use your foot on the ground to push off.
2. Press the rear fender foot brake with your foot to slow down or stop.
3. The scooter performs best when on a smooth surface e.g. carparks, smooth roads, footpaths, & bike lanes.
4. Always clean your scooter (wheels, platform, etc.), it's a machine and it needs to be maintained.
5. Be aware of the terrain you are riding on, watch out for curbs and obstacles!

How to turn on/off the lights?

1. When you step on the front button, the lights will turn on.
2. When the scooter is not in the usage, you can turn the lights off by pressing any of these 2 sensor buttons.
3. Lights will automatically turn off after 1 minute of none operations.

Maintenance & Repair

If you regularly clean and maintain your electric scooter, it will extend its life.

Cleaning and storage: If the scooter is dirty, wipe it clean with a soft damp cloth.

DO NOT use alcohol, gasoline, kerosene, or other corrosive chemical solvents to clean the scooter. It can severely damage the appearance and structure of the scooter. Please do not use a pressure washer as it may also cause damage to the electronics.

Storage: When you're not using your scooter store in a dry and cool location. Avoid storing your scooter outdoors because sun exposure can damage its appearance and may cause wear on the life of the battery and tires.



Battery Information

Only use the approved GOTRAX power adapter to charge your scooter, others may cause risk of fire & equipment may be damaged.

Improper disposal of used batteries may seriously pollute the environment. Please comply with local disposal regulations.

Make sure to store your scooter and power adapter in conditions that do not exceed 122 degrees Fahrenheit or below -4 degrees Fahrenheit.

Warning - Risk of Fire - No User Serviceable Parts, The prolonged exposure to UV Rays, Rain and the Elements may damage the enclosed materials, store indoors when not in use.

Troubleshooting

We frequently update our user manuals at **GOTRAX.com**, and reserve the rights to update and change manuals online.

Please contact our customer service team if you are experiencing problems or need more detailed information. They can be reached at GOTRAX.com

Warranty

For warranty information, please visit **GOTRAX.com**.



WWW.GOTRAX.COM

#RideGOTRAX





GOLABS, INC

GOTRAX.com
2201 Luna Rd.
Carrollton, TX 75006