

KAIA

LIA

INSTALLATION MANUAL

LIA

Suspension
Wall 100

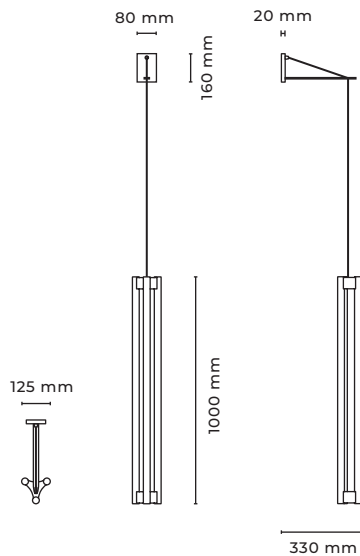

Type
Material
Environment
Dimensions
Cable Length
Weight
Certification
EU/UK
Lamps

Suspension light
Brass
Indoors
1000 mm
Standard mounting 1500 mm
2.1 kg
IP20 CE
230 V
max. 3 x 120W, S14s
our suggestion:
3 x linear opal LED, 2700 K, 1055 lm,
Mains (Phase) dimmable,
EPREL-ID: 566195;

LIA

Suspension
Wall 50

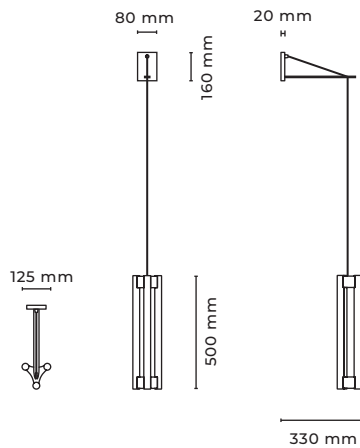

Type
Material
Environment
Dimensions
Cable Length
Weight
Certification
EU/UK
Lamps

Suspension light
Brass
Indoors
500 mm
Standard mounting 1500 mm
1,9 kg
IP20 CE
230 V
max. 3 x 60W, S14s
our suggestion:
3x linear opal LED, 2700 K, 470 lm,
Mains (Phase) dimmable,
EPREL-ID: 566200;

LIA

Suspension
Wall 30

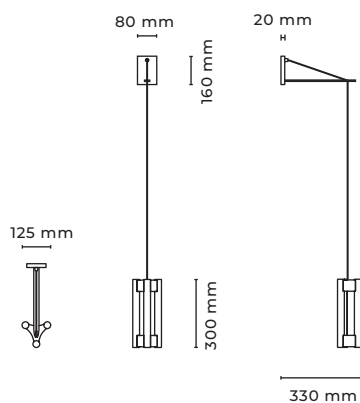

Type
Material
Environment
Dimensions
Cable Length
Weight
Certification
EU/UK
Lamps

Suspension light
Brass
Indoors
300 mm
Standard mounting 1500 mm
1,8 kg
IP20 CE
230 V
max. 3 x 35W, S14s
our suggestion:
ex linear opal LED, 2700 K, 275 lm,
Mains (Phase) dimmable,
EPREL ID 566198;

INSTALLATION

Before commencing installation ensure the relevant mains supply has been safely isolated/disconnected. Installation should be carried out by a qualified electrician. Ensure all electrical connections are tight with no loose strands, including factory made connections. The Mains power must only be switched on once the fitting has been electrically connected to the driver.

Fit the 3 lamps before starting the installation (see next page).

1. Remove the base from the installation bracket.
2. Affix the bracket to the ceiling with 2 screws (hole size max. 4,5 mm) . Distance between the holes : 90 mm.
3. Connect the unit to the mains.
4. Fix the unit back on its base and re-tighten 2 screws on the side.

STEP 1

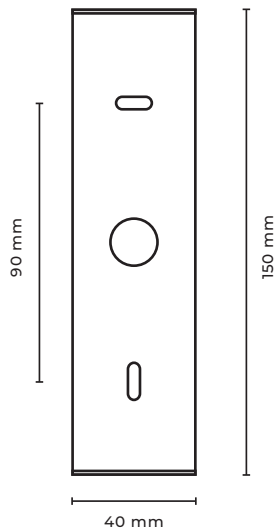

STEP 2

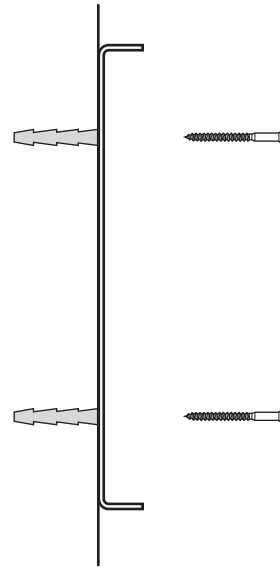

STEP 3

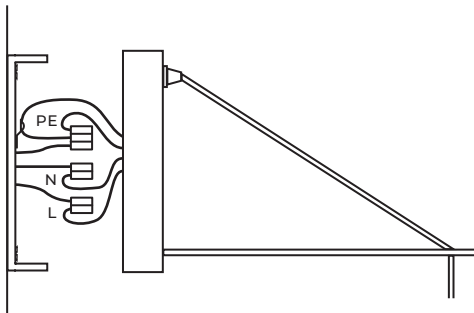

STEP 4

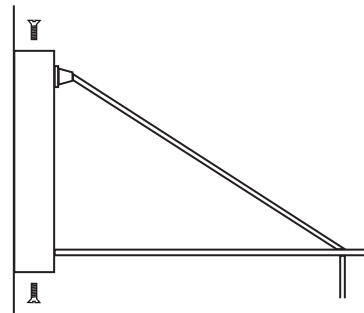

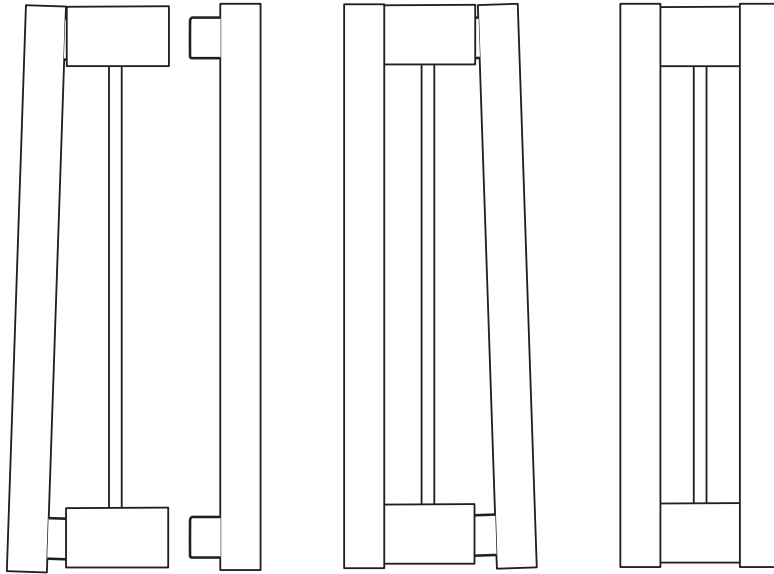

LAMP INSTALLATION

- Before commencing installation ensure the relevant mains supply has been switched off.
- Use supplied fabric gloves to prevent any stains on the surface of the lamp.
- Due to risk of glass fracture handle the lamp with care!
- Whilst applying pressure push the socket into the lamp holder in the marked place. Remove the lamp from the lamp holder carefully with both hands.

CARE INSTRUCTIONS

* On very rare occasions, these lamps may appear to have a slight buzzing or flickering. As is the case with all retro LED lamps, this is likely caused by a number of outside influences such as incorrect installation, wiring, dimming or transformers and in some instances low electrical resistance.

** Please contact sales@kaialighting.com for further information on dimmers etc. Please note KAIA Ltd cannot take any responsibility for the connection with your dimming or central control system. It is the customer's responsibility to ensure the compatibility with their systems.