

CEDARAPIDS[®]
A TEREX BRAND

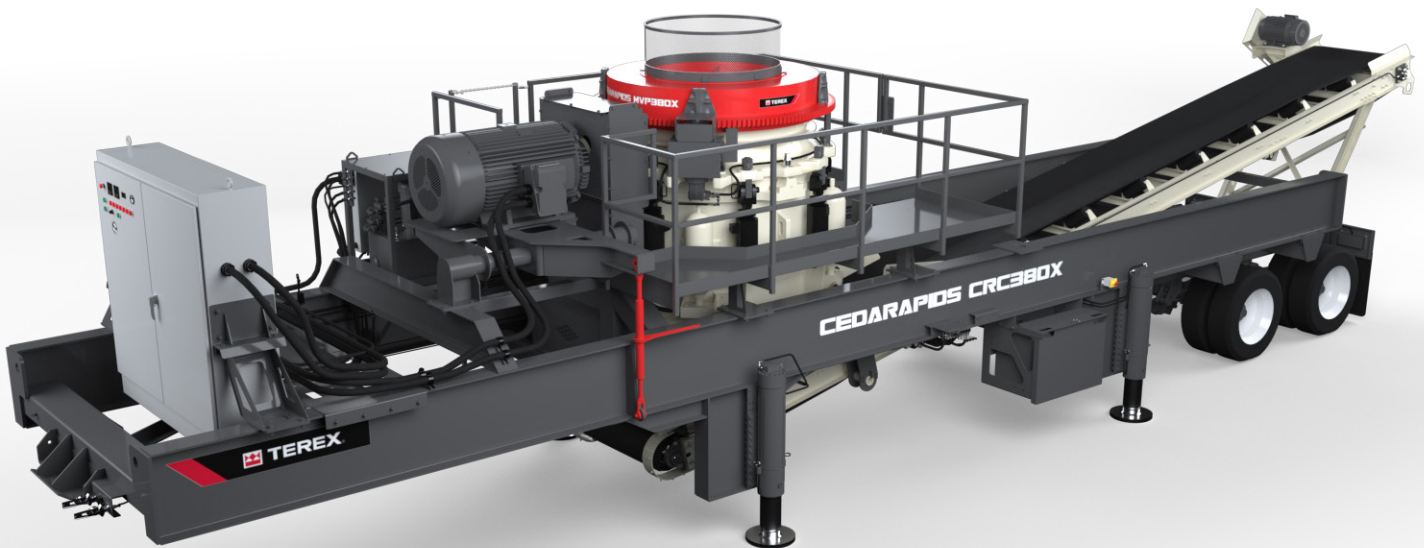

Portable Plants

CRC380X
Cone Plant



A world working better™

Cedarapids® Portable Plants

CRC380X Cone Plant

The Cedarapids® CRC380X cone plant is built for portability, especially for applications involving hard abrasive materials. This open circuit all electric plant can be tied in with any portable crushing operation and is commonly set up in secondary, tertiary, and quaternary crushing positions. The CRC380X is available with a variety of options including feed conveyors and extra length under crusher conveyors.

Standard Features

- High efficiency MVP380X cone crusher with roller bearing construction
- Single 300 hp (224 kW) crusher motor with easy adjust cone crusher drive
- Mesh cone hopper extension
- "Straight-line" undercrusher conveyor; 42" x 34'6" (1067 x 10,515 mm); 15 hp (11 kW)
- 3-ply conveyor belt with vulcanized belt splice
- Service platforms around crusher with guard rails and access ladder
- Easy maintenance features
 - Ratchet cone drive belt tensioning
 - Conveniently located grease banks
 - Ground access cone lubrication module
 - Large undercrusher hinged access panel
- Emergency stop buttons on both sides of frame
- Tandem axle spring suspension
- Eight 295/75 R22.5 tires
- Lockable 4' (102 mm) long side-mounted storage box

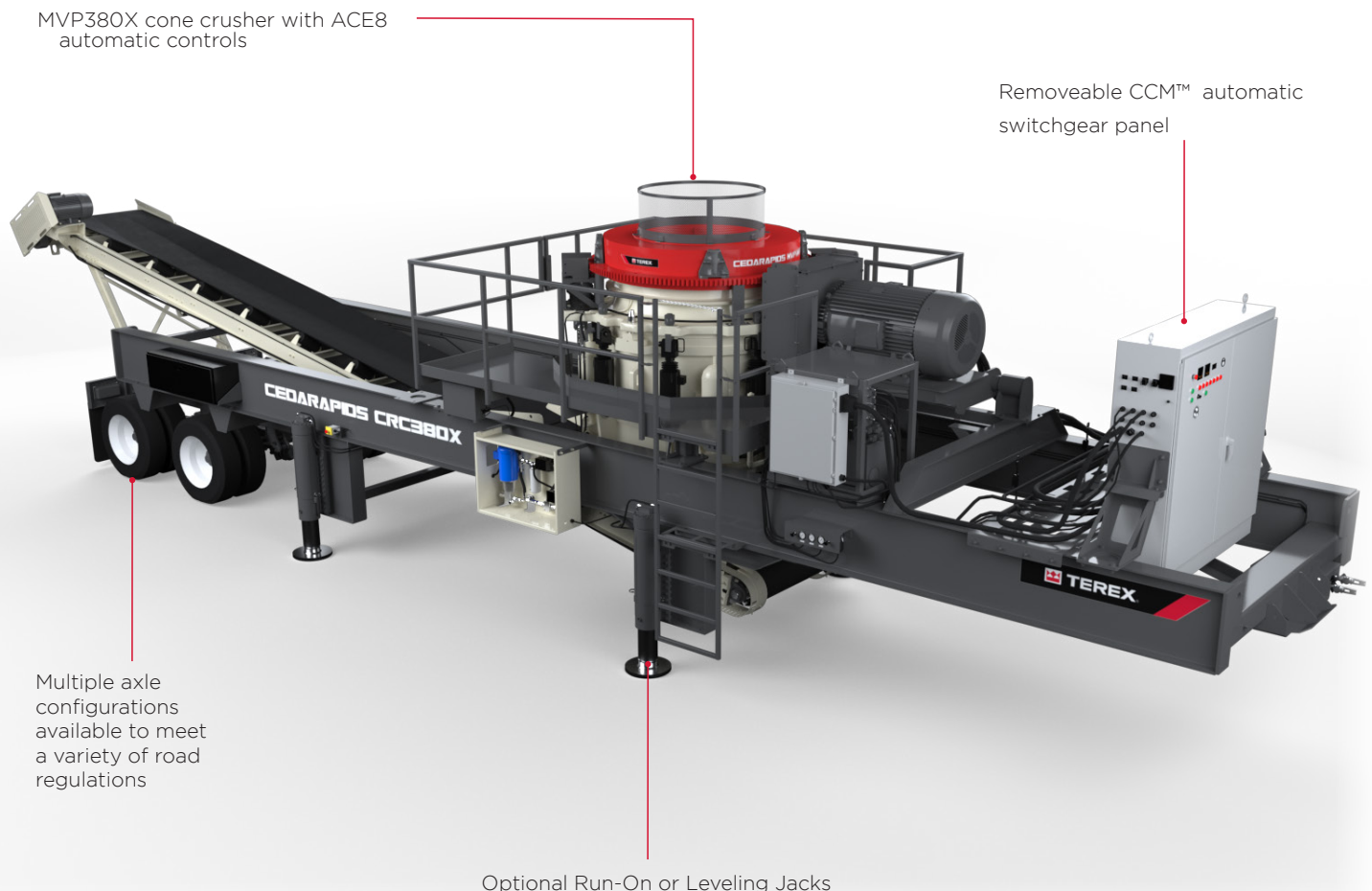

Optional Equipment

- Oversized quick release cone surge hopper
- Crusher overflow chute to undercrusher conveyor
- Extended undercrusher conveyor with hydraulic adjust discharge; 42" x 45" (1067 x 13,716 mm); 15 hp (11 kW)*
- Feed conveyor with hydraulic positioning (LH or RH); 36" x 36" (914 x 10,973 mm); 15 hp (11 kW)*
- Triple axle spring suspension with drop-down rear stabilizing legs
- Conveyor skirt boards
- CCM™ automatic switchgear panel
- Hydraulic leveling or run-on jacks (gas, 12V or 24V powered)
- Power cables and quick disconnects
- Oversize 315/80 R22.5 tires
- Dust suppression water spray system
- Belt wiper

*Requires triple axle option and hydraulic leveling or run-on jacks option

Estimated Weights*	Axles	Kingpin	Total
Plant with standard discharge conveyor (tandem axle)	37,907	43,646	81,553

Plant with in/out conveyors (triple axle)	52,212	41,079	93,291
---	--------	--------	--------

*Weights above include optional overflow chute, switchgear, and 4 run-on jacks

Power Requirements	hp	Kw
Cone crusher	300	224

Cone hydraulic pump	15	11
---------------------	----	----

Cone lube pump	2	1.5
----------------	---	-----

Undercrusher conveyor	15	11
-----------------------	----	----

Extended undercrusher conveyor (optional)	15	11
---	----	----

Feed conveyor (optional)	15	11
--------------------------	----	----

Transport Dimensions

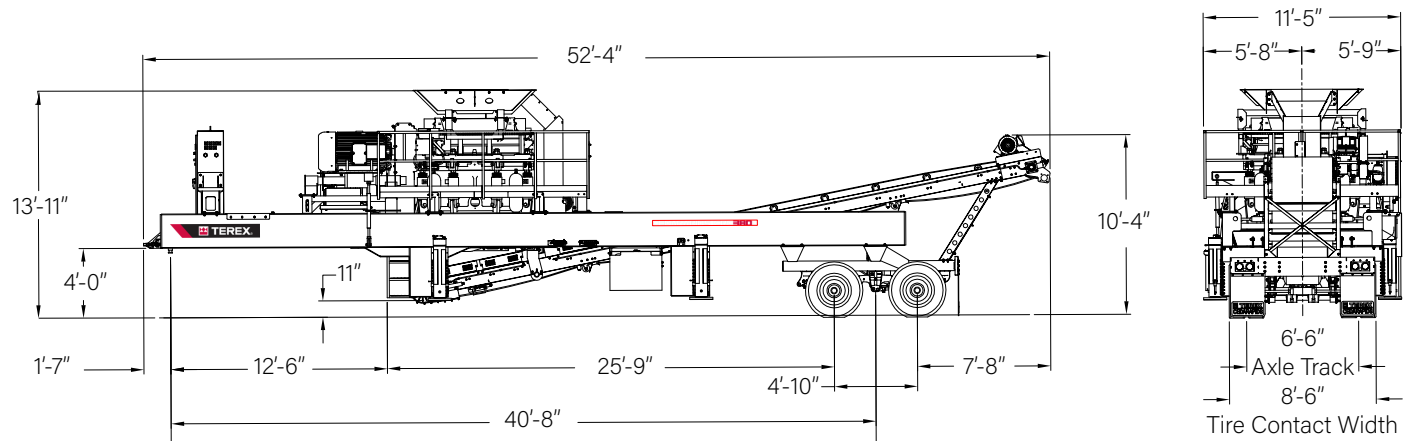

Working Dimensions

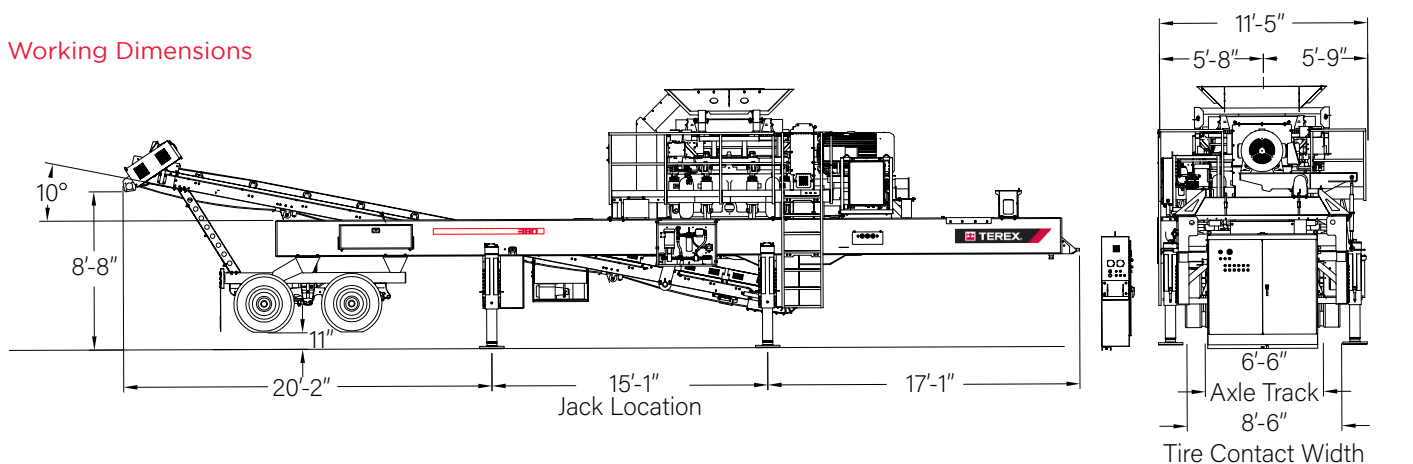

Working Dimensions - Optional

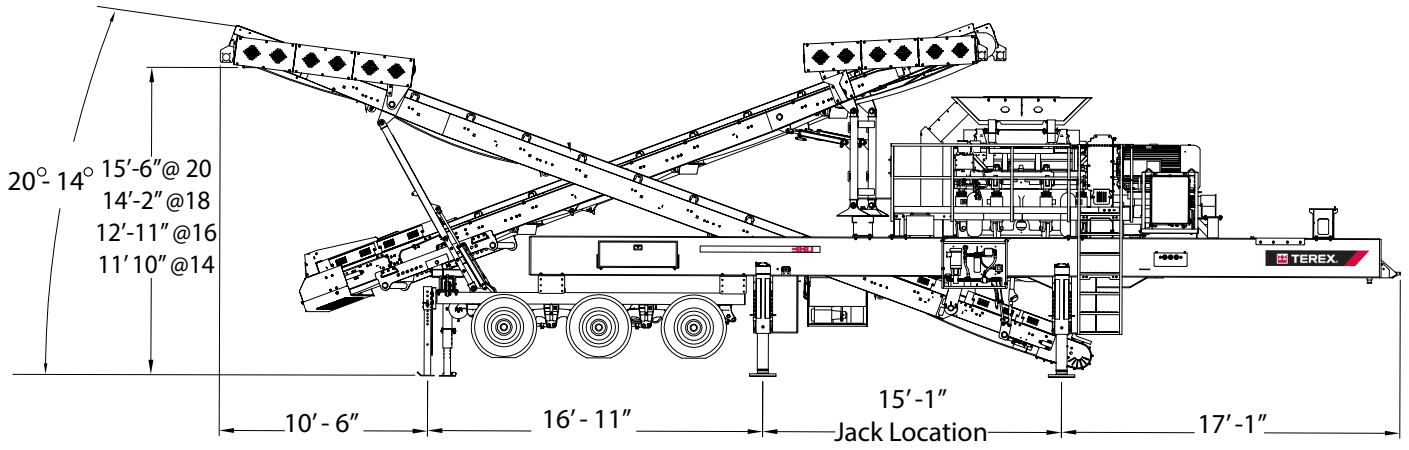

Note: All drawings shown with optional overflow chute, switchgear and run-on jacks