

CEDARAPIDS[®]
A TEREX BRAND

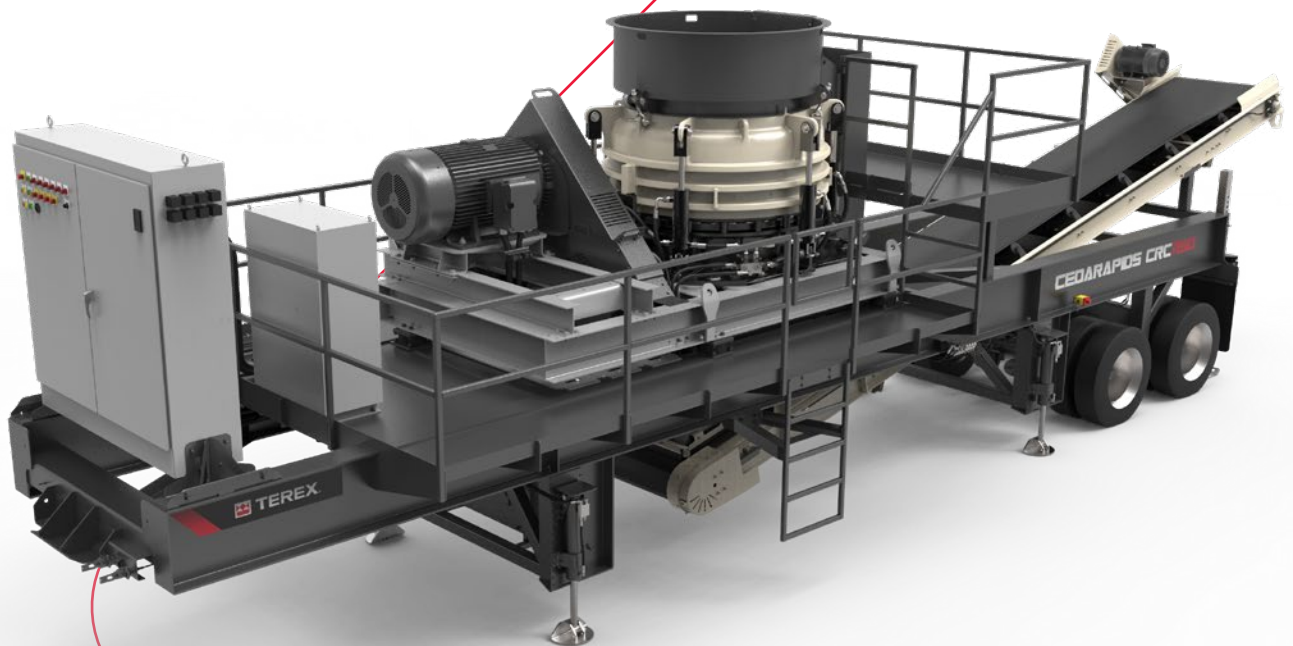

Portable Plants

CRC1150
Cone Plant



A world working better™

 **TEREX**.MPS

Cedarapids® Portable Plants

CRC1150 Cone Plant

The Cedarapids® CRC1150 cone plant delivers big production at an affordable price. The highly mobile plant features the TC1150 cone crusher that utilizes high efficiency roller bearings and boasts several notable advancements that enhance performance and functionality. Key features include automated cone controls and larger closed side settings. The crusher is powered by a 300 hp (225 kW) motor and drive, all mounted on a rubber isolated frame. The plant includes an oversize cone feed hopper extension with overflow chute, "straight-line" undercrusher conveyor, metal detector, and service platforms. Easy maintenance features include conveniently located grease banks and a ground access cone lubrication module.

Standard Features

- TC1150 cone crusher: standard mantle and medium coarse concave poured, oil lubrication tank with air blast cooler with piping, standard crusher tool kit and ACE 6 automated cone controls
- 300 hp (225 kW) 1800 rpm crusher motor and drive mounted with crusher on rubber isolated frame
- Oversize quick-release cone feed hopper with gated overflow chute
- 42" x 34'-6" (1067 x 10515 mm) "straight-line" undercrusher conveyor with 15 hp (11 kW) electric motor and shaft mount gearbox
- 3-ply conveyor belt with vulcanized belt splice and primary style belt wiper
- Metal detector for off-plant feed conveyor (interlocked with off-plant feed conveyor if plant is outfitted with the optional switchgear panel); lockable stowage box for metal detector
- Service platforms around crusher, elevated observation platform, guard rails and access ladders

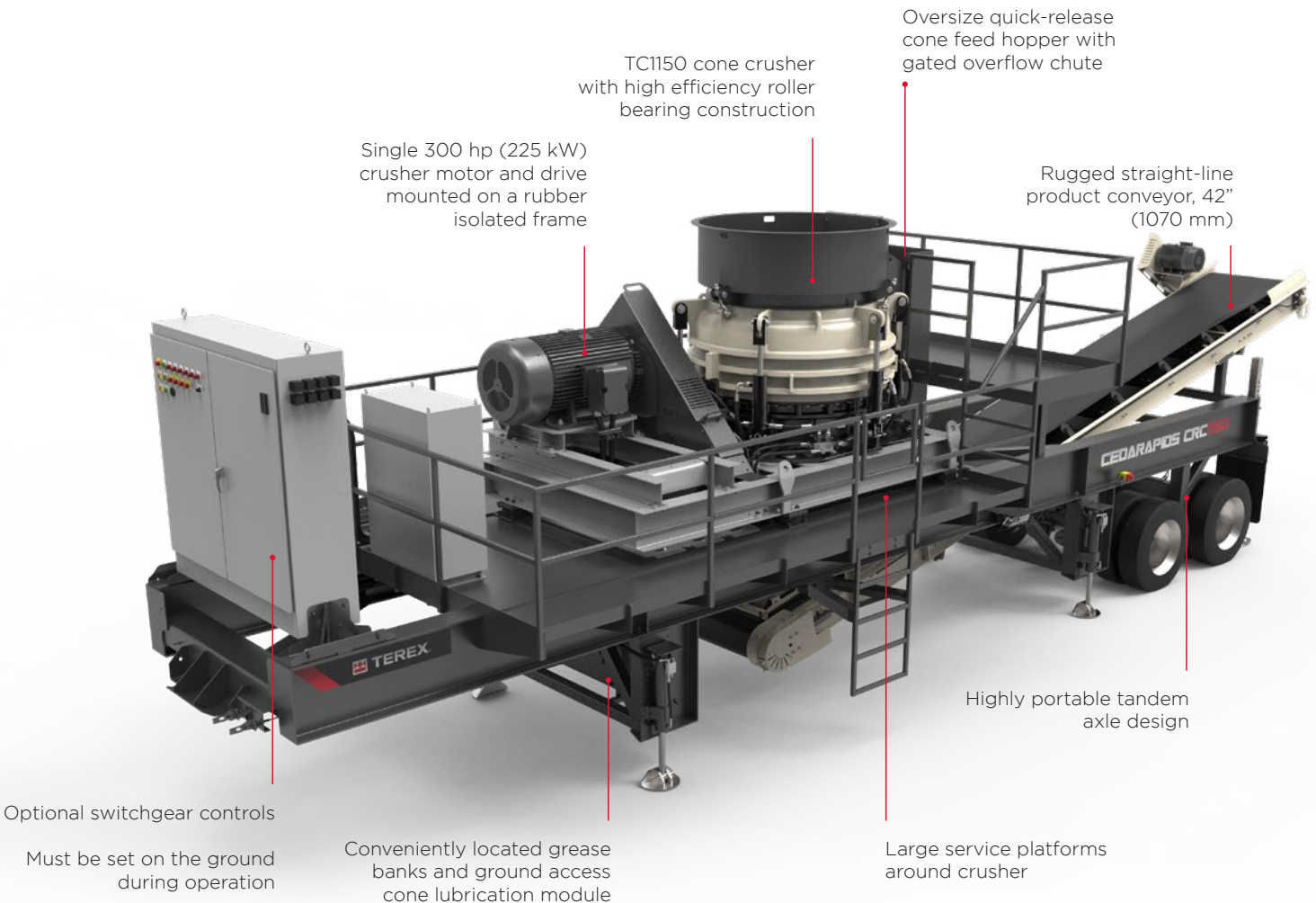

- Easy maintenance features
 - Conveniently located grease banks
 - Ground access cone lubrication module
- Emergency stop stations on both sides of frame
- Tandem axle spring suspension
- Eight 295/75 R22.5 tires
- Side-mounted lockable storage box
- Manual crank-style landing jacks

Options

- Removable electrical switchgear panel with crusher soft start and door-mounted controls, two 25 hp (20 kW) off-plant conveyor controls
- Hydraulic leveling or run-on jacks (gas, 12V powered)
- Power cables and quick disconnects
- Oversize 315/80 R22.5 tires

Cone Specifications

	Metric	Imperial
Motor Size	225 kW	300 hp
Cone Head Diameter (nominal)	1150 mm	45"
Maximum Feed Size	220 mm	8.5"
Maximum Closed Side Setting	45 mm	1.75"
Capacity @ 1" (25 mm) CSS	220 - 260 MTPH	240 - 285 STPH
Basic Crusher Weight	14,225 kg	31,360 lb
Bearing Type Thrust	Taper Roller	
Bearing Type Radial	Roller	
Adjustment	Hydraulic Cylinder	

Note: Listed throughput capacity, maximum feed size and motor requirements are approximate and will vary depending on material properties, feed gradation, moisture content, chamber selection, feed method and other site specific operating conditions



TC1150 Cone

Transport Dimensions

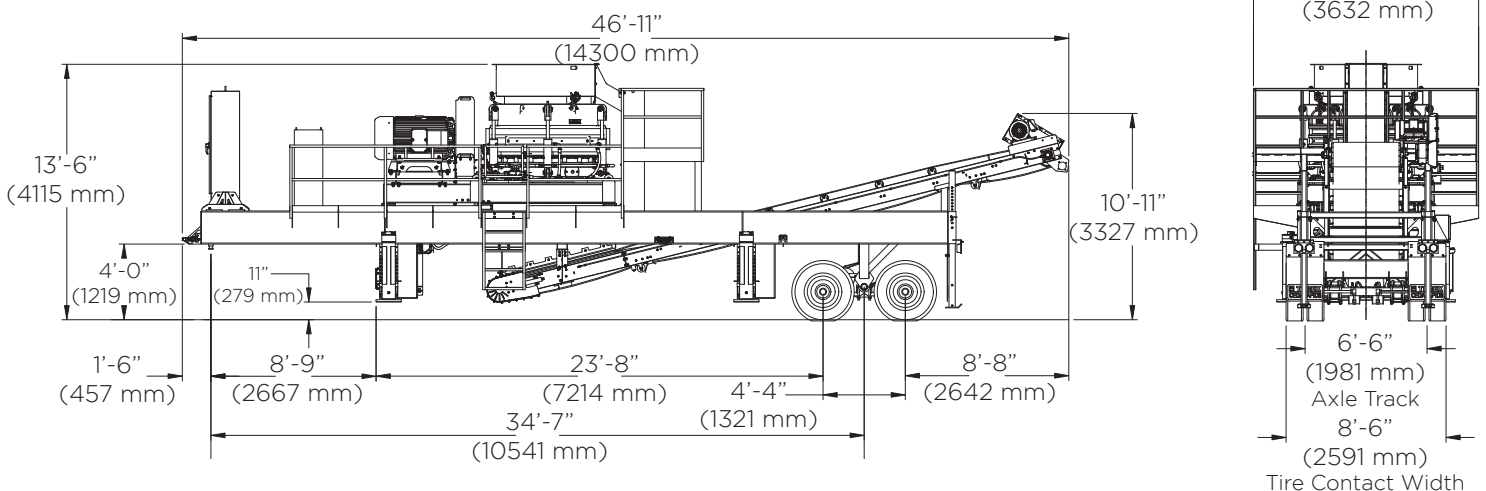

Shown with optional run-on jacks and switch gear controls.

Estimated Weights	Kingpin	Axle	Total
Base plant with optional run-on jacks and electric power panel	33,900 lb (15,380 kg)	35,200 lb (15,970 kg)	69,100 lb (31,350 kg)

Operation Dimensions

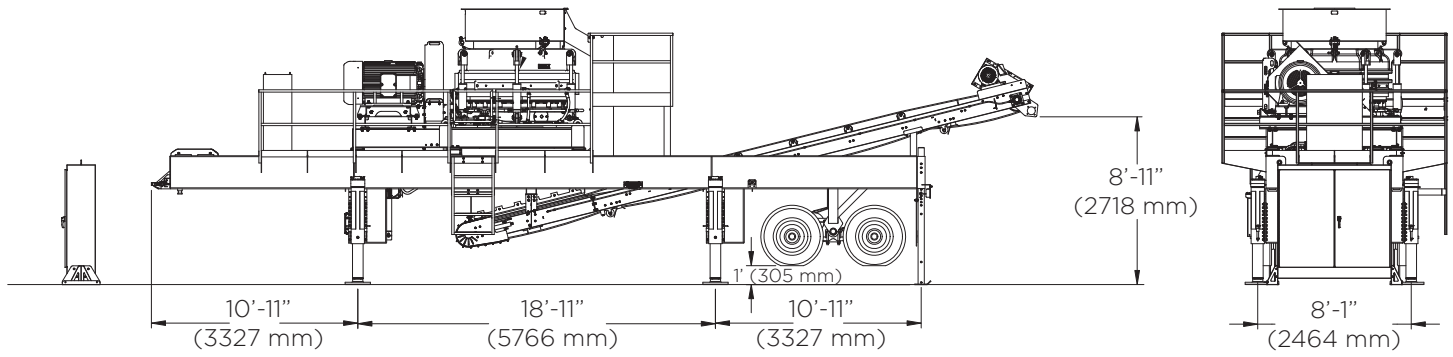

Power Requirements	hp	kW
Cone crusher	300	225
Undercrusher conveyor	15	11