



A TEREX BRAND



**EMERALD**  
EQUIPMENT SYSTEMS INC.

# CHIPMAX 484

WHOLE TREE  
CHIPPER



AVAILABLE AS TRACKED, PORTABLE, AND TRUCK-MOUNTED



This compact and reliable chipper consistently out-produces the competition by up to 50 percent on a daily basis and has a high-production capability of up to 120 tons per hour. Compact yet enormously productive, the CBI ChipMax 484 whole tree chipper hit the market with an eye on productivity and customer flexibility. The rotor, chipper box, and feed system are the strongest in its class as this drum chipper provides owners with years of trouble free service. No other drum chipper currently on the market challenges machine operators to keep up as much as this extreme-duty biomass production workhorse.

# PRODUCTION RATES UP TO 120 TONS AN HOUR.

## REDESIGNED INFEED



Larger feed opening, lower winged side walls, sloped deck, and reverse pivoting feed yoke make feeding brush and tops easy.

FUEL CHIPS



MICRO CHIPS



484BT Tracked



484VT Tracked

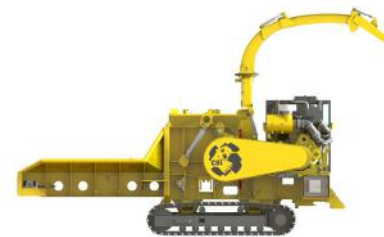

484BP Portable



484VR Truck-Mounted



Rotating discharge chute for top loading of trailers and 290° rotation for broadcast chip spreading minimize truck relocation during loading. Available in straight, flexible, or vertical configurations. \*Pictured in vertical.

Infeed accepts logs up to 24" in diameter. Option of apron-style conveyor to prevent material spillage or four strand, heavy-duty drag chain to screen abrasive material.



Standard, pivoting, or rotating chip deflector options to ensure smooth and precise discharge.

CAT, C-18, 755 HP Tier 4 final engine.



500 mm triple grouser tracks on tracked models.

IQAN control system with radio remote control.

## Rotor options

Featuring two rotor options, the CBI 484 makes high-quality fuel chips custom sized from 12–25 mm or “micro-chips” from 2–12 mm from logs up to 24” in diameter. These wood micro-chips produce a consistent fiber length that dramatically reduces the overall cost of producing pellets and improves the function of small boilers.

Two pocket rotor



Four pocket rotor



Easy access for knife changes

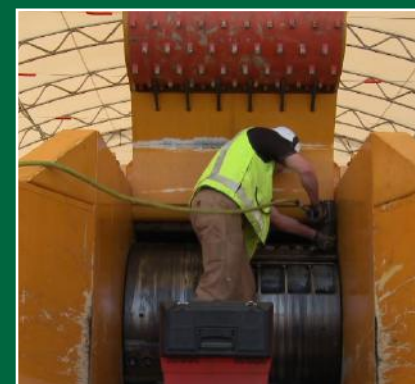

Dynamic chip deflector options



Quickly adjusts to loading angle





### ChipMax 484BT

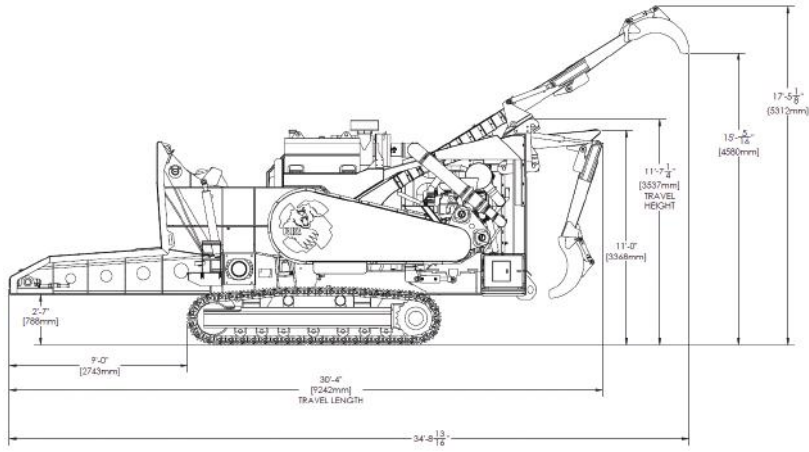

### ChipMax 484BP

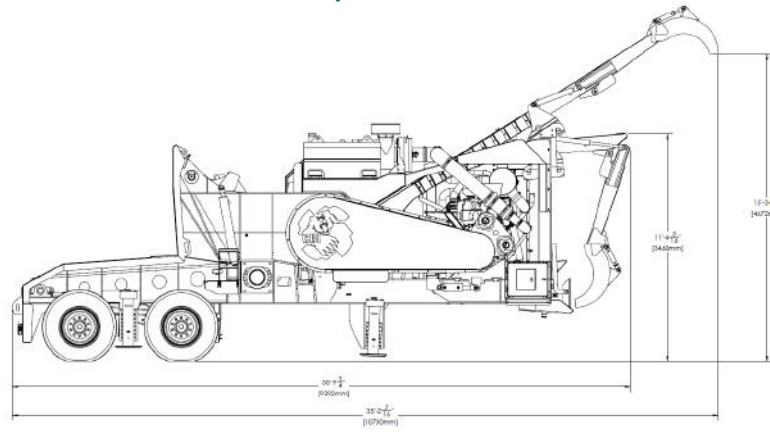

### ChipMax 484VT

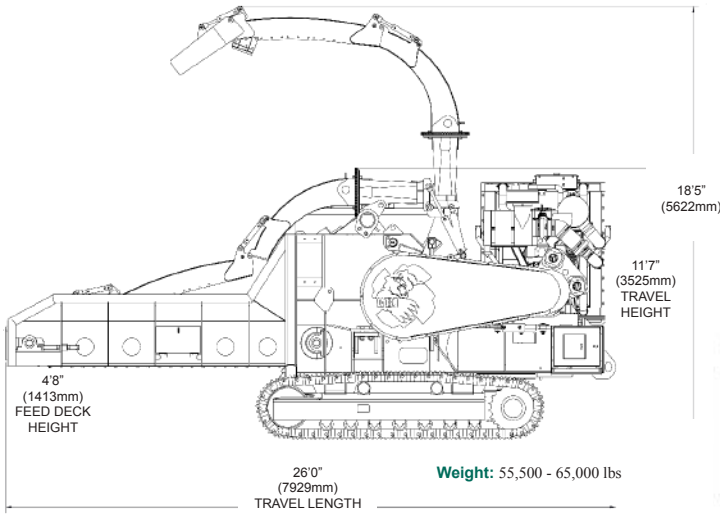

### ChipMax 484VR

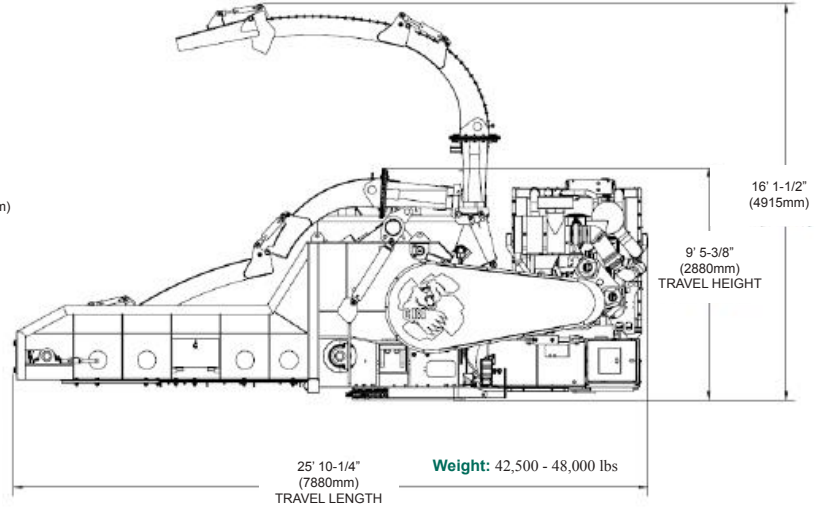

MODEL	WEIGHT	TRAVEL HEIGHT	TRAVEL LENGTH	WIDTH	ENGINE	INFEED	ROTOR
484BT	56,000 lbs.	11'- 7" (3525 mm)	30'- 4" (9200 mm)	8'- 4" (2.5 m)	CAT C-18, 765 HP	48" W	48" W, 40" D
484BP	55,000 lbs.	13'- 6" (4100 mm)	30'- 2" (9100 mm)	8'- 4" (2.5 m)	CAT C-18, 765 HP	48" W	48" W, 40" D
484VR	42,500 - 48,000 lbs.	9' 5" - 5.375" (2880 mm)	25'- 10.25" (7880 mm)	8'- 4" (2.5 m)	CAT C-18, 765 HP	48" W	48" W, 40" D
484VT	55,500 - 65,000 lbs.	11'- 7" (3525 mm)	26' 0" (7929 mm)	8'- 4" (2.5 m)	CAT C-18, 765 HP	48" W	48" W, 40" D



**Continental Biomass Industries**  
World's best stationary and portable material recovery systems.

Distributed by:

