

HAKKO 153 LEAD FORMER 154

Instruction Manual 153 [Standard]
154 [5 mm (0.2 in.) Pitch]

Thank you for purchasing the HAKKO 153/154 Lead Former. This manual contains a simple explanation of the use of the unit. Be sure to read it before using the HAKKO 153/154 and keep the manual handy for easy reference.

Package Contents

Main Unit.....	1	Hexagon Wrench/2mm (0.08 in.).....	1
Parts Tray.....	1	Hexagon Wrench/2.5mm (0.1 in.).....	1
Clamp.....	1	Hexagon Wrench/3mm (0.12 in.).....	1
Handle.....	1	Hexagon Wrench/4mm (0.16 in.).....	1

Specifications

Name	HAKKO 153	HAKKO 154
Forming Size	5.6 mm (0.22 in.) Pitch	5 mm (0.2 in.) Pitch
External Dimensions	125(W) x 130(H) x 110(D) mm [4.9(W) x 5.1(H) x 4.3(D) in.]	
Approximate Weight	2 kg (4.4 lbs.) including handle and clamp	

Compatible Taping Dimension

Outer width of tape	Max. 85 mm (3.3 in.)
Pitch	5 mm (0.2 in.)

•Cutting & Forming HAKKO 153

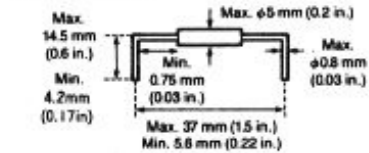

HAKKO 154

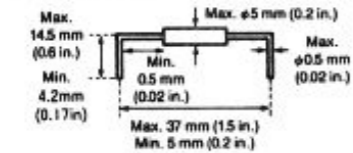

•Forming only HAKKO 153

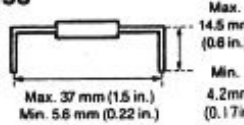

HAKKO 154

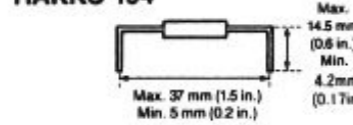

•Cutting only HAKKO 153-154

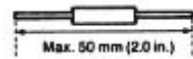

Related Products

HAKKO 152 MOTOR DRIVE

Motor drive for Lead Formers and Lead Cutters. Ensures accurate, high-speed processing at stable torque.

Specifications

Name	HAKKO 152
Motor Speed (rpm.)	40 rpm. (50Hz) 48 rpm. (60Hz)
External Dimensions	360(W) x 150(H) x 140(D) mm [14.2(W) x 5.9(H) x 5.5(D) in.]
Approximate Weight	5.1 kg (11.2 lbs.)
Processing Capacity	Max. 60,000 leads per hour when combined with the HAKKO 153/154

HAKKO 156 PARTS FEEDER

Used for cutting and forming of individual parts. A variety of parts can be processed without changing the drum.

Specifications

Name	HAKKO 156
External Dimensions	136(W) x 49(H) x 131(D) mm [5.4(W) x 1.9(H) x 5.2(D) in.]
Approximate Weight	0.4 kg (0.9 lbs.)

HAKKO

HAKKO CORPORATION
HEAD OFFICE
TEL: +81-6-6561-3225 FAX: +81-6-6561-8466
http://www.hakko.com E-mail: sales@hakko.com
OVERSEAS AFFILIATES
U.S.A.: AMERICAN HAKKO PRODUCTS, INC.
TEL: (661) 294-0090 FAX: (661) 294-0096
Toll Free (800)88-HAKKO
http://www.hakkousa.com

HONG KONG: HAKKO DEVELOPMENT CO., LTD.
TEL: 2811-5588 FAX: 2590-0217
http://www.hakko.com.hk
E-mail: info@hakko.com.hk
SINGAPORE: HAKKO PRODUCTS PTE. LTD.
TEL: 6748-2277 FAX: 6744-0033
http://www.hakko.com.sg
E-mail: sales@hakko.com.sg

Please access to the following address for the other Sales affiliates.
http://www.hakko.com/address

Part Names

(P) = Pulley side
(H) = Handle side

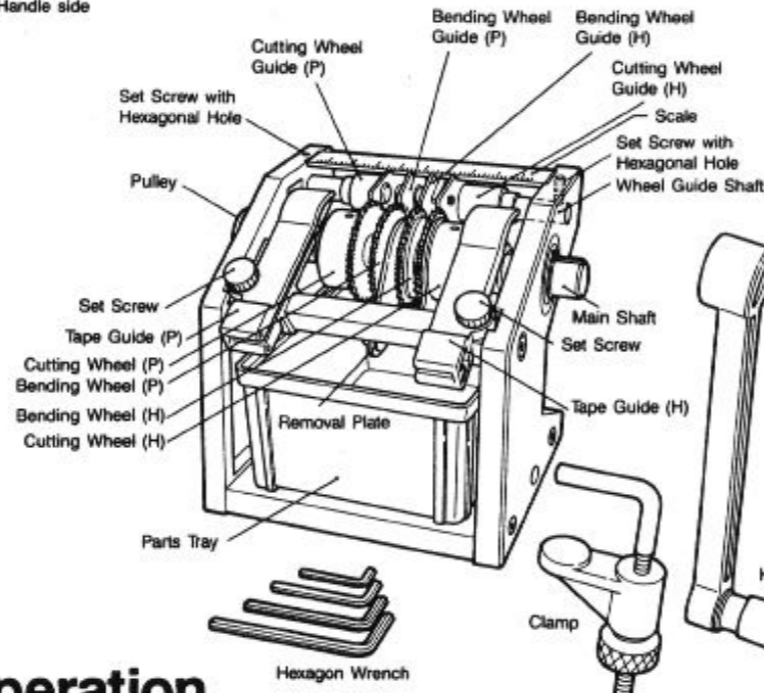

Parts List

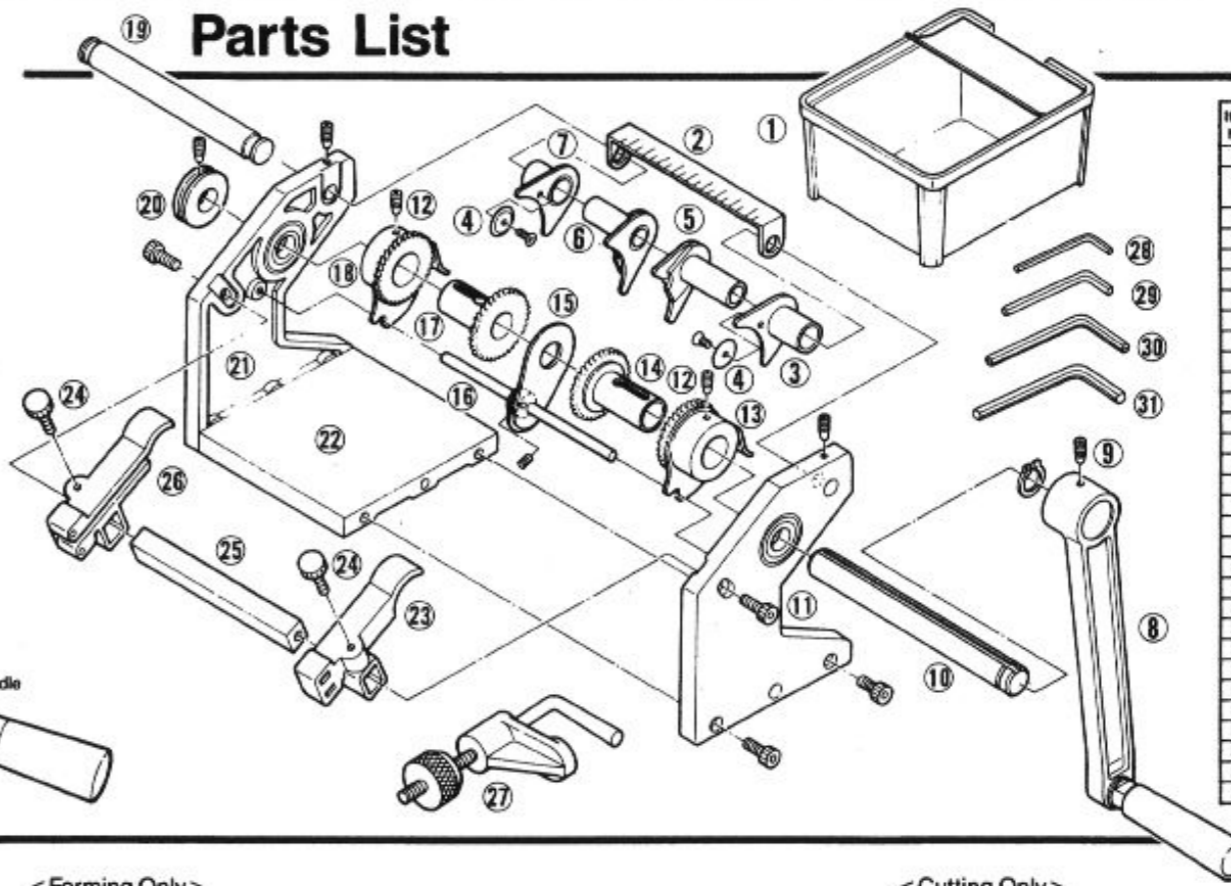

Item No.	Part No.	Part Name	Description	
1	B1397	Parts Tray	with cover	
2	B1385	Scale		
3	B1546	Scale (inch)		
4	A1095	Cutting Wheel Guide (H)		
4	A1106	Cutting Wheel Guide (P)		
5	A1099	A1103	Bending Wheel Guide (H)	
5	A1098	A1102	Bending Wheel Guide (P)	
7	A1094	Cutting Wheel (P)		
8	B1398	Handle	with screw	
9	B1415	Adjustment Screw (C)		
10	B1387	Main Shaft		
11	B1384	Side Plate (H)	with screws	
12	B1413	Adjustment Screw (A)		
13	A1097	Cutting Wheel (H)		
14	A1101	A1105	Bending Wheel (H)	
15	B1395	Removal Plate	with screw	
16	B1393	Plate Shaft		
17	A1000	A1104	Bending Wheel (P)	
18	A1096	Cutting Wheel (P)		
19	B1386	Wheel Guide Shaft		
20	B1391	Pulley	with screw	
21	B1383	B1399	Side Plate (P)	with screws
22	B1394	Base Plate		
23	B1388	Tape Guide (H)	with set screw	
24	B1390	Set Screw		
25	B1392	Tape Guide Shaft		
26	B1389	Tape Guide (P)	with set screw	
27	B1396	Clamp		
28	B1416	Hexagon Wrench 2 mm		
29	B1417	Hexagon Wrench 2.5 mm		
30	B1117	Hexagon Wrench 3 mm		
31	B1418	Hexagon Wrench 4 mm		

Operation

< Preparations for Use >

- Fasten unit in place.**
 - Use the Clamp to mount the unit to the workbench.
- Attach Handle.**
 - Insert the Handle so the end of the Adjustment Screw (C) fits into the groove on the Main Shaft, then tighten the screw with the 3mm (0.12 in.) Hexagonal Wrench.

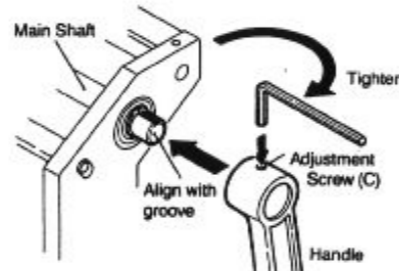

< Cutting and Forming >

- Set the forming size.**
 - Using the 3mm (0.12 in.) Hexagonal Wrench, loosen the two Adjustment Screws (A) on the Cutting Wheel.
 - Adjust the position of the Bending Wheel Guide to the desired forming size.

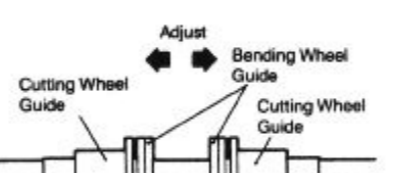

The outer edge of the Bending Wheel Guide is the forming point. The lead wires will be bent along the outside of the Bending Wheel Guide.

- Set the cutting size.**
 - Adjust the position of the Cutting Wheel Guide to the desired cutting size.

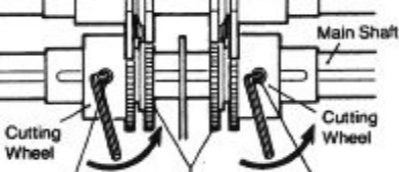

Remember that the inside of the Cutting Wheel Guide will be the cutting size.

- After the desired settings have been made, tighten the Adjustment Screw on the Cutting Wheel.

The screws should fit perfectly into the grooves on the Main Shaft or the Bending Wheel and tighten.

- Set the parts tray in place.**
 - The cover should go on the side with the Scale.

- Set the Tape Guide in place.**
 - Loosen the Set Screw on the Tape Guide.
 - Adjust the Tape Guide to the width of the part to be taped, then fasten it in place by tightening the Set Screw.

In order to make sure that the tape does not get caught, the Tape Guide should be set to slightly wider than the width of the taped part. Be careful not to set it too wide, since this may result in misalignment.

- Place the taped parts in position.**
 - Place the parts so they catch on the gears of the Bending and Cutting Wheels, then turn the Handle slowly, while holding the first row of parts, until they catch on the Wheel Guides.

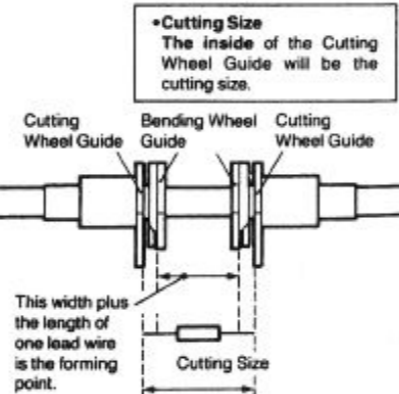

< Forming Only >

When only forming parts, the maximum size that can be processed is shown in the diagram below:



Note With sizes over 14.5mm (0.6 in.), forming accuracy cannot be guaranteed.

- Remove the Cutting Wheel Guide.**
 - Using the 2mm (0.08 in.) Hexagonal Wrench, loosen the two Set Screws with Hexagonal Holes holding on the Wheel Guide Shaft.
 - Pull out the Wheel Guide Shaft and remove the Cutting Wheel Guide.

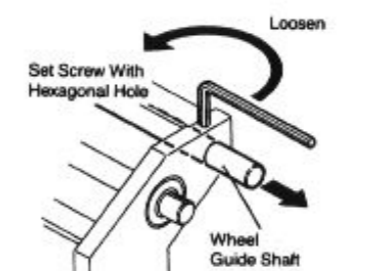

- Set the Bending Wheel Guide in place.**
 - Insert the Wheel Guide Shaft and attach the Bending Wheel Guide.

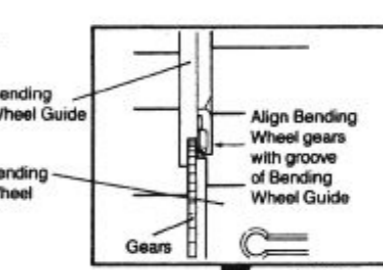

When mounting, align the groove on the Bending Wheel Guide with the Bending Wheel gears, as shown in the figure at left.

- Fasten the two Set Screws with Hexagonal Holes as before.

- Set the forming size.**
 - To set the forming size, use the same procedure as described in "1 Set the forming size" in the "Cutting and Forming" section.

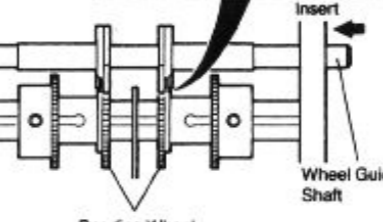

Direction of Cutting/Bending Wheel Guides

The figures below show the (P) (pulley) sides of the guides. Be careful to mount them in their proper directions.



•Cutting Wheel Guide •Bending Wheel Guide

< Cutting Only >

When only cutting parts, the maximum size that can be processed is shown in the figure below:

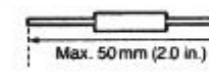

- Switch the Cutting Wheel Guide and the Bending Wheel Guide.**
 - Using the 2mm (0.08 in.) Hexagonal Wrench, loosen the two hexagonal-hole Set Screws with securing the Wheel Guide Shaft, then remove the Wheel Guide Shaft.
 - Switch the positions of the Cutting Wheel Guide (P) and the Bending Wheel Guide (H).
 - In the same manner, switch the positions of the Cutting Wheel Guide (H) and the Bending Wheel Guide (P).

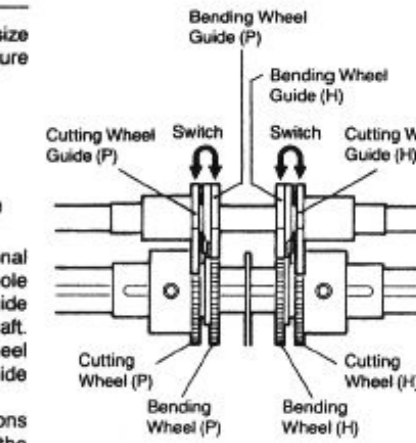

- Assemble the mechanism.**
 - Insert the Wheel Guide Shaft and mount the Cutting Wheel Guide and Bending Wheel Guide.

When mounting, align the groove on the Cutting Wheel Guide with the Cutting Wheel gears, as shown in the figure at left. There is no need to align the Bending Wheel and the Bending Wheel Guide.

- Set the cutting size.**
 - To set the cutting size, use the same procedure as described in "2 Set the cutting size" in the "Cutting and Forming" section of this manual.

