



Nectre N60

Operating Instructions



Keep these instructions for future reference



Glen Dimplex Australia proudly supports the activities of Landcare Australia through its membership of the AHHA

CONTENTS

1. OPERATING	1
1.1. IMPORTANT INFORMATION	1
1.2. GENERAL OPERATION	2
1.3. USING THE APPLIANCE FOR THE FIRST TIME	2
1.4. RECOMMENDED FUELS	2
1.5. LIGHTING THE FIRE	2
1.6. RUNNING THE APPLIANCE	3
1.7. BURNING TIPS	3
1.8. ASH REMOVAL	4
1.9. FLUE/CHIMNEY FIRE	4
1.10. CLEANING PAINT WORK AND GLASS	4
1.11. CLEANING THE FLUE	4
1.12. TROUBLESHOOTING TIPS	4
2. MAINTENANCE AND SERVICING	5
2.1. REPLACING THE FIRE BRICKS	5
2.2. REPLACING THE BRICK RETAINER	5
2.3. REPLACING THE BAFFLE PLATES	5
2.4. ADJUSTING THE DOOR	6
2.5. REPLACING DOOR GLASS	6
2.6. REPLACING THE DOOR SEAL	6
2.7. REPLACEMENT SPARE PARTS LIST	6
3. WARRANTY	1

1. OPERATING

THE OPERATING INSTRUCTIONS IN THIS MANUAL APPLY TO THE NECTRE N60 WOOD HEATER MODEL.

IT HAS BEEN TESTED FOR EMISSIONS AND EFFICIENCY AND COMPLY ACCORDING TO AS/NZS 4012 & AS/NZS 4013.

1.1. IMPORTANT INFORMATION

Before use of this appliance please read these instructions fully.

WARNING: ANY MODIFICATION OF THE APPLIANCE THAT HAS NOT BEEN APPROVED IN WRITING BY THE TESTING AUTHORITY IS CONSIDERED AS BREACHING AS/NZS 4013.

WARNING: DO NOT USE FLAMMABLE LIQUIDS OR AEROSOLS TO START OR REKINDLE THE FIRE.

WARNING: DO NOT USE FLAMMABLE LIQUIDS OR AEROSOLS IN THE VICINITY OF THIS APPLIANCE WHEN IT IS OPERATING.

WARNING: DO NOT STORE FUEL WITHIN HEATER INSTALLATION CLEARANCES.

WARNING: WHEN OPERATING THIS APPLIANCE AS AN OPEN FIRE USE A FIRE SCREEN.

WARNING: OPEN AIR CONTROL (AND DAMPER WHEN FITTED) BEFORE OPENING FIRING DOOR.

WARNING: DO NOT BURN WOOD THAT IS PAINTED; OR IS COATED WITH PLASTIC; OR HAS BEEN TREATED WITH ANY CHEMICAL.

CAUTION: THIS APPLIANCE SHOULD NOT BE OPERATED WITH A CRACKED GLASS.

CAUTION: THIS APPLIANCE SHOULD BE MAINTAINED AND OPERATED AT ALL TIMES IN ACCORDANCE WITH THESE INSTRUCTIONS.

The appliance or flue system should not be modified in any way without the written approval of the manufacturer.

Extractor fans or cooker hoods must not be placed in the same room or space as this can cause appliance to emit smoke into the room.

1.2. GENERAL OPERATION

AIR CONTROLS

The Nectre N60 has a single top air control for controlling the fire.

This air control allows air to enter the firebox from above the door where it is then drawn down into the base of the fire while keeping the glass clean.

Top air slide handle



DOOR HANDLE

Warning: door handle may get hot if appliance has been left in High burn setting for an extended periods.

The N60 is supplied with a stainless steel handle extension which can be inserted into the end of the door handle. This extension allows the door to be opened and closed without the risk of burning ones hand.

Open the top air control before opening the door to eliminate the chance of backdraft and/or smoke entering the room.

1.3. USING THE APPLIANCE FOR THE FIRST TIME

For the first few times the appliance is lit, odorous fumes will be given off as the paint cures.

Do not touch the paint work while it is curing otherwise it can leave a permanent mark on the appliance.

Keep the room well ventilated until these fumes have cleared.

Once the paint has cured, this will not re-occur.

1.4. RECOMMENDED FUELS

Burn only seasoned hardwood timber with a moisture content of less than 20%.

Newly cut wood should be split and allowed to dry/season for 12 to 18 months before use.

Wood should be stored in an environment protected from the weather to minimise any potential moisture content.

For best results, wood should not exceed $\frac{3}{4}$ of the firebox front to back dimension in length and 150mm in diameter. Any larger and appliance will not operate at its optimum. It is better to burn several smaller pieces of wood than one large piece at a time.

Poor quality timber:

- Causes low combustion efficiency.
- Produces poor emissions (smoky).
- Results in additional build-up of creosote (soot) in the flue which will then require regular cleaning and may result in a flue fire.

Do not burn painted, impregnated/treated wood, manufactured board products or pallet wood.

1.5. LIGHTING THE FIRE

- 1) Place firelighters or paper and dry kindling wood in the base of the firebox.
- 2) Fully open air control (slide top air slide to the left).
- 3) Light the paper or firelighters.
- 4) Once the fire has taken hold add larger pieces of wood. For optimal burn conditions, place the logs in a front to back orientation (right angles to the door opening). Too many logs may smother the fire.

Do not leave the appliance unattended while the door is open.

1.6. RUNNING THE APPLIANCE

High Heat Output

- After establishing the fire and loading it with larger pieces of wood, leave it running with the air control fully open.
- Note that this setting is not the most energy efficient as some heat is lost up the flue instead of being transferred into the room.
- Running the appliance with the door open will not produce maximum heating in the room as it will draw a lot of already warmed air out of the room.
- Do not overload firebox with fuel.

Low Heat Output

- The heat output of the heater can be reduced by closing the air control (slide handle to the right) which will restrict the oxygen supplied to the fire thereby slowing down the rate at which the wood burns.
- This setting will provide the best energy efficiency as the wood burns for longer. However, if not operated correctly may result in higher particulate emissions.
- **Prior to closing the air control** ensure that the fire is burning briskly. This may require leaving the air control fully open for 10-15mins before shutting down.
- For the optimum between clean burning, and getting the best in efficiency from the heater, from the fully closed position, open the air control a couple of millimetres.

The air control can be adjusted to any position so desired depending on wanted heat output versus burn time.

Reload with more wood

- 1) Open the air slide before opening the door.
- 2) Rake / break up any existing coals.
- 3) Load wood with the length orientated front to back. Better results will be achieved by loading several smaller pieces of wood rather than one large piece.
- 4) Close the door with the air slide fully open and leave for a minimum of 10 minutes to allow the fresh wood to catch.
- 5) After 10 or more minutes, the air slide can be adjusted to the desired heat output setting.

1.7. BURNING TIPS

Fuel Quality

Use wood with a moisture content of less than 20%. Logs should not feel moist or have moss and fungal growths.

Symptoms of burning wet wood:

- Difficulty starting and keeping a fire burning well
- Smoke and only small flames
- Dirty glass and/or fire bricks
- Rapid creosote build-up in the flue/chimney
- Low heat output
- Short burn times, and blue/grey smoke from the flue/chimney outlet

Run appliance at high heat output for a short period each day to avoid large build-up of tars and creosote within the appliance and flue.

Flue Draught

The flue has two main functions:

- 1) To safely remove smoke, gases and fumes from the appliance.
- 2) To provide sufficient draught (suction) in the appliance to ensure the fire keeps burning.

Draught is caused by the rising hot air in the flue when the fire has been lit.

The position, height and size of the flue can affect the performance of the flue draught. Refer to installation guide for details on flue installation.

Factors affecting the flue draught include:

- Insufficient flue height
- Trees or other buildings nearby causing turbulence
- High and gusty winds
- Outside temperature and weather conditions
- Blocked flue

For advice on the correction of persistent flue problems consult your supplier/installer for more detail.

1.8. ASH REMOVAL

Depending on the type of wood burnt and frequency, the ashes will need removing every 2 to 6 weeks.

Excess ashes should be removed when necessary, placed in a non-combustible container such as the ash pan beneath and moved outdoors immediately to a location clear of combustible materials.

Leave a small amount of ash, approximately 10mm thick, in the bottom of the firebox. This helps to insulate the base of the firebox.

1.9. FLUE/CHIMNEY FIRE

If a flue/chimney fire occurs:

- Shut air slide fully to smother the fire.
- Do not use the appliance after a flue fire until an accredited installer has assessed the cause and any resultant damage.

1.10. CLEANING PAINT WORK AND GLASS

- The appliance, when cool, can be cleaned with a damp cloth.
- Over the years, the black paint will fade and can be touched up with Stove Bright metallic black paint.
- To clean the glass, we recommend using a household window cleaner or general purpose cleaner with a soft cloth.

Do not use abrasive cleaner or scourer pads.

1.11. CLEANING THE FLUE

Check inside of flue prior to each season for any build-up of creosote (wood tar).

To check the flue:

- 1) Remove the baffle plates (refer to 'Replacing the Baffle Plates' under Maintenance & Servicing).
- 2) Hold a small mirror on an angle below the flue, with a torch shining towards it, and look for black creosote build-up. It is normal to see a fine black powdery layer, but if built up layers of creosote can be seen, the flue requires cleaning.
- 3) If no cleaning is required, re-fit the baffle plate.

To clean the flue:

- 1) A flue cleaning brush can be purchased from most wood heater retail outlets or large hardware stores. Alternatively, hire a flue cleaning service to do the job for you (it's a dirty job).
- 2) With the baffle plates removed, tie a rope to one end of the brush, and drop the rope down the flue (from outside on top of the roof).
- 3) Grab the end of the rope from inside the firebox and pull the brush down through the flue.
- 4) Check the inside of the flue with the mirror and torch.
- 5) Repeat cleaning process if necessary.
- 6) Once the flue is clean, remove any excess creosote from the firebox.
- 7) Replace the baffle plate.

Only pull brush downwards through flue, as pulling upwards may separate the flue sections at their joins.

1.12. TROUBLESHOOTING TIPS

1. Glass in door blackening

This can have several possible causes:

- i) **Burning unseasoned wood** — if the wood is too wet, it will cause the glass to blacken.
- ii) **Appliance operated at low temperature** — after an overnight burn where the air slide control has been fully closed, the glass may have blackened. When the fire is re-stoked and burning on the high heat setting, the blackened glass should self-clean.
- iii) **Problems with the flue** — insufficient flue draught can cause the glass to blacken. If the flue is too short, not properly insulated, or in a position that results in a downdraught, then there will be insufficient flue draught. Contact the installer should this happen.

2. **Trouble starting the fire** — if all ash has been removed from the firebox, then it can upset the supply of air to the base of the fire. It can aid the fire by retaining some ash when cleaning out the firebox.

3. **Glass cracking** — Do not over tighten the screws on the retainer that holds the door glass in place. Otherwise, expansion of the door may cause the glass to crack.

2. MAINTENANCE AND SERVICING

2.1. REPLACING THE FIRE BRICKS

The purpose of the firebricks in the heater is to increase thermal mass and to guarantee the longevity of the steel firebox. Over time the firebricks may become cracked and crumble away. If so, then they should be replaced soon after.

To replace the firebricks:

- i) Move any ash away from the base of the bricks.
- ii) Raise the brick retainer so that the bricks can be removed.
- iii) Replace with new bricks, and refit brick retainer.

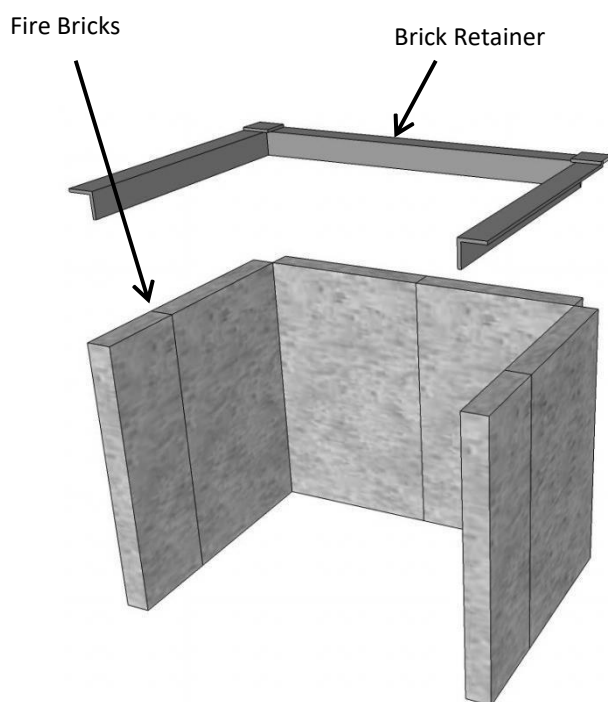

2.2. REPLACING THE BRICK RETAINER

1. Over time the original brick retainer may burn out, in which case it can be replaced with a new one.
2. Raise the old brick retainer and remove the firebricks. Remove the old retainer.
3. Rotate the new brick retainer on a slight angle to get it through the door and into the firebox. While holding it up, refit the firebricks and then fit the retainer over the top locking them into position.

2.3. REPLACING THE BAFFLE PLATES

The Nectre N60 is fitted with two 6mm thick steel baffle plates which help to retain the heat in the firebox by lengthening the path of the flame as well as protect the top of the heater.

Over time, the baffle plates may begin to sag a little due to the excessive heat. This will not affect the way the fire burns.

Eventually the baffle plates may burn through (5+ years) and if so will need to be replaced.

Before the baffle plates can be removed, the firebricks need to be removed.

To remove the baffle plates:

- i) Lower baffle plate (360(w) x 260(d) x 6(h)) :- raise the rear of the baffle plate until it clears the rear support lugs, slide it forward and up so that the rear of the baffle plate can be brought down into the firebox. Lower the baffle plate until the front edge clears the front support lugs, then bring it out through the door opening.
- ii) Upper baffle plate (300(w) x 200(d) x 6(h) mm) :- slide baffle plate forward, free from the rear support lug, then down until it clears the front support lugs, and out through the door opening.
- iii) Repeat steps i) to ii) in reverse to replace with the new baffle plates.

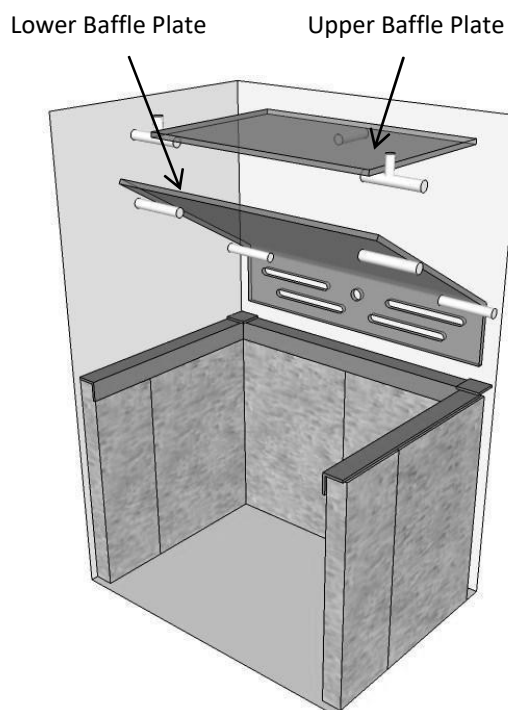

2.4. ADJUSTING THE DOOR

If the door does not close firmly, then the door latch can be adjusted.

With the 4mm Allen key supplied, slightly loosen the two screws fastening the latch to the side of the firebox body. Gently tap the latch only a millimetre to start with.

Retighten the screws and test for any improvement. If no improvement, repeat process until door can be closed firmly.

2.5. REPLACING DOOR GLASS

This task may be easier with the door removed from the appliance and laid horizontally on a work-bench.

To remove the door:

- i) With the Allen key supplied, remove the top air control handle from the air slide.
- ii) Open the door 90°.
- iii) With one hand on top of the door and the other supporting it underneath, raise it on the hinge pin until the top door hinge clears the top of the hinge pin.
- iv) Lower the door until the lower door hinge clears the bottom of the pin.

To replace the door glass:

- i) The door glass is held in position by the rectangular glass retainer fixed by four M6 screws, two at the top and two at the bottom.
- ii) With 4mm Allen key supplied, remove the four screws and the glass retainer.
- iii) Take out the glass and any old door seal rope.
- iv) The new glass will have been supplied with a length of grey door seal attached to the outer edge of the glass.
- v) Refit the new glass with door seal into position in the door. Place the glass retainer over the top and fasten with the four M6 screws.
- vi) Take extra care not to over-tighten the screws, otherwise the glass will crack when the heater gets hot and the door expands.

2.6. REPLACING THE DOOR SEAL

This task may be easier with the door removed from the heater and laid horizontally on a work-bench (refer to Section 2.5. on how to remove the door).

- i) Remove any old seal from the door.
- ii) Clean out the groove in the door that the seal was bedded in using a flat-end screw driver or equivalent.
- iii) Run a thin bead of clear roof and gutter silicone along the groove.
- iv) Starting with the end that has the silver tape around it, press the new door seal rope into the groove on the door.
- v) When get to the end there will be a small amount of excess rope. Trim this to the right length, remove the backing from the adhesive silver tape supplied with the rope and wrap the tape around the end that has been trimmed. Fit the end of the rope into the groove.
- vi) Refit the door if it has been removed and close.

2.7. REPLACEMENT SPARE PARTS LIST

Firebricks:	4 x full bricks – 270(h) x 175(w) x 25(d)mm 2 x half bricks – 270(h) x 85(w) x 25(d)mm
Brick Retainer:	395mm x 290mm
Upper Baffle Plate:	300(w) x 200(d) in 6mm steel
Lower Baffle Plate:	360(w) x 260(d) in 6mm steel
Glass seal:	1550mm x 8mm x 4mm flat adhesive back
Glass:	431mm x 325mm x 5mm
Door rope:	1500mm x 13mm round braided ceramic rope
Glass Base:	500mm x 430mm x 5mm Black or Clear Toughened Glass

3. WARRANTY

Glen Dimplex Australia Pty. Ltd. warrants this stove to be able to operate under normal use and service and within 10 years from the date of the original purchase on the terms herein shall repair or replace without cost to the original customer any part thereof which shall be returned to our factory, transportation charges prepaid and which our inspection shows would prevent operation.

This warranty does not apply to firebricks, brick retainer, baffle, door seal, glass, nor discolouration of the surface or tarnishing of chrome fittings all of which require normal service to maintain them.

Under the terms of this warranty, Glen Dimplex Australia Pty. Ltd. assumes no responsibility for the labour costs involved in removing or replacing the stove. Nor shall Glen Dimplex Australia Pty. Ltd. be liable for any injury, loss, or damage (direct, indirect or consequential) arising out of the use or inability to use the product, or its removal and replacement. All other stove warranties, expressed or implied are excluded to the extent possible to law. Any claims against Glen Dimplex Australia Pty. Ltd. must be brought within Australian Jurisdiction.

Electric fans and any remote sender or transmitter are warranted against failure to operate for a period of 1 (one) year from original purchase date.

The Retailer does not have the authority to alter this warranty.



Glen Dimplex Australia Pty Ltd

8 Lakeview Drive,
Scoresby Victoria 3179
Australia

T: 1300 556 816 | F: 1800 058 900

General and Sales Enquiries: flame@glendimplex.com.au

Technical Service: service@glendimplex.com.au

www.glendimplex.com.au