



3 Garden Street, Morwell Vic 3840  
ABN: 46 610 154 768

**PREPARED FOR**

# SCHOTS HOME EMPORIUM



## **THERMAL CLEARANCE TESTING OF THE DOMINA SW-1120 FREE-STANDING APPLIANCE**

Report Number: ASFT21055-PRELIMINARY REPORT  
Issue date: 25 June 2021

By:  
Garry Wayne Mooney

## Report Distribution

### Schots Home Emporium

400 Hoddle Street  
Clifton Hill VIC 3068

Mr Don Savige

ASFT Report Archive

## Revision Details

Revision	Date	Comments
0	25/06/2021	Preliminary report – awaiting payment and engineering drawings of appliance

### Disclaimer

This Report is intended only for the use of the individual or entity named above (Intended Recipient). ASFT is not liable to the Intended Recipient in respect of any loss, damage, cost or expense suffered as a result of reliance on the information contained in this Report or any actions taken or not taken on the basis of this Report. In particular, results presented in this Report relate exclusively to the samples selected by the Intended Recipient and no responsibility is taken for the representativeness of these samples.

This report shall not be reproduced except in full, without written approval of ASFT.

QD-001R1

Copyright © 2021 ASFT

## THERMAL CLEARANCE TESTING OF THE DOMINA SW-1120 FREE-STANDING APPLIANCE

### Report

The Domina SW-1120 Free-standing appliance installed with a Flo-met SG-FLKIT 200-FS-B Flue Kit was tested in two positions in a manner conforming to joint Australian/New Zealand Standard 2918:2018, Appendix B.

A minimum 1,400mm deep x 1,175mm wide x 50mm thick floor protector (Skamol board) should be used under and in front of the appliance base when installing the appliance (see joint AS/NZS 2918:2018 3.3.2). The floor protector should extend 850mm in front of the appliance door and be placed centrally in the 1,175mm width. The Thermal resistivity of the floor protector is 0.74m<sup>2</sup>.K/W for 50mm thick skamol board sheets. Minimum air gap of 25mm must be maintained under the appliance base to the Skamol floor protector.

The flue system must incorporate an additional 900mm long, 13" galvanized piece flue casing above the ceiling from the ceiling ring and a minimum 25mm clearance around the flue outer casing to any combustible material at the ceiling penetration.

The Domina SW-1120 Free-Standing solid fuel appliance installed with a Flo-met SG-FLKIT 200-FS-B Flue Kit conforms to the requirements of the joint AS/NZS 2918:2018 Standard, Appendix B.

The appliance and flue system were tested at the following clearances:

Position A – Parallel position

Position B – Corner position

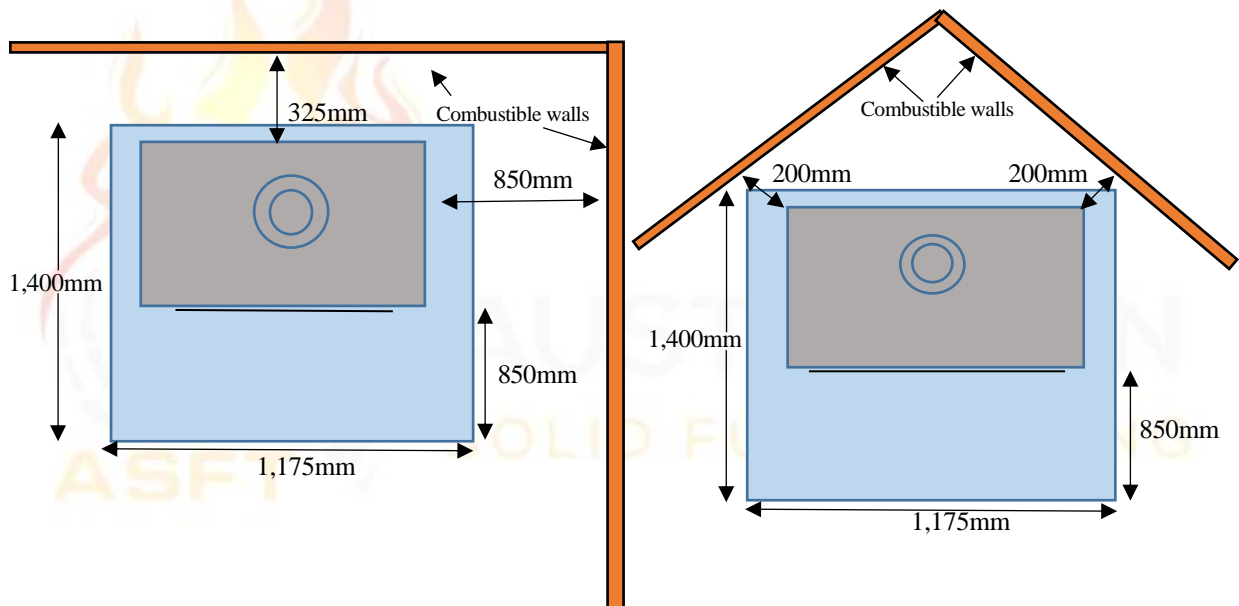



Figure 1 – Clearance Diagram

<b>Signed</b>		<b>Approved</b>	
<b>Name</b>	Garry W. Mooney	<b>Name</b>	Steve Marland
<b>Title</b>	Technical Officer	<b>Title</b>	Managing Director – Australian Solid Fuel Testing
<b>Date</b>	25/06/2021	<b>Date</b>	25/06/2021

## 1. INTRODUCTION

Thermal Clearance testing of the Domina SW-1120 appliance and flue system took place on 23 and 24 June 2021 at the Australian Solid Fuel Testing Laboratory located at 3 Garden Street, Morwell, Victoria. The testing was performed by Mr G.W. Mooney and Mr S. Marland.

## 2. PROCEDURE

Testing was conducted as per Appendix B of AS/NZS2918;2018, Hot sites were located with the aid of an infra-red thermometer. Thermocouple tips were stapled onto the test surfaces, with black tape over the first 100 mm to facilitate consistent and accurate recording of temperatures.

Thermocouple positions are shown in the table below:

### Position A – Parallel Position

Thermocouple No.	Position	Thermocouple No.	Position
1	Floor - 1300mm in front of centre	16	Floor – 150mm RHS of centre
2	Floor – 1200mm in front of centre	17	Floor – 300mm RHS of centre
3	Floor - 1050mm in front of centre	18	Floor – 450mm RHS of centre
4	Floor – 900mm in front of centre	19	Ceiling Ring – Inner front
5	Floor – 750mm in front of centre	20	Ceiling Ring – 25mm in front
6	Floor – 600mm in front of centre	21	Ceiling Ring – Inner side
7	Floor – 450mm in front of centre	22	Ceiling Ring – 25mm to side
8	Floor – 300mm in front of centre	23	Rear wall – 1279mm from corner, 2139mm above the floor
9	Floor – 150mm in front of centre	24	Rear wall – 1211mm from corner, 1472mm above the floor
10	Floor – Centre of flue	25	Rear wall – 1233mm from corner, 1007mm above the floor
11	Floor – 150mm behind centre	26	RHS wall, 1590mm from corner, 460mm above the floor
12	Floor – 300mm behind centre	27	RHS wall, 390mm from corner, 1517mm above the floor
13	Floor – 450mm LHS of centre	28	RHS wall, 1393mm from corner, 487mm above the floor
14	Floor – 300mm LHS of centre	29	Rear wall – 1218mm from corner, 1299mm above the floor
15	Floor – 150mm LHS of centre	30	Ambient temperature

### Position B – Corner Position

Thermocouple No.	Position	Thermocouple No.	Position
19	Ceiling Ring – Inner front	25	LHS wall – 890mm from corner, 1254mm above the floor
20	Ceiling Ring – 25mm in front	26	RHS wall, 881mm from corner, 1085mm above the floor
21	Ceiling Ring – Inner side	27	RHS wall, 952mm from corner, 930mm above the floor
22	Ceiling Ring – 25mm to side	28	RHS wall, 728mm from corner, 1338mm above the floor
23	LHS wall – 662mm from corner, 2036mm above the floor	29	LHS wall, 788mm from corner, 1324mm above the floor
24	LHS wall – 997mm from corner, 996mm above the floor	30	Ambient temperature

TABLE 1

### **3. TEST FUEL**

Testing was conducted with Pinus Radiata as the test fuel which had a moisture content of 11.0% moisture. Each firewood piece was 300mm x 100mm x 50mm.

### **4. FLUE SYSTEM**

The flue system used during testing was a Flo-met SG-FLKIT 200-FS-B Flue Kit incorporating a 515mm ceiling ring with a 15mm air gap between the ceiling and the ceiling ring which was manufactured by Floate Metal Fabrications Pty Ltd. This flue kit used a Solid Painted casing above the appliance. This flue system has not been tested to joint AS/NZS 2918:2018, Appendix F. The flue height was  $4.6 \pm 0.1$ m from the floor protector. Appendix 1 shows details of the flue system.

### **5. RESULTS**

#### **5.1 High Fire Test**

The appliance was fired in accordance with Section B9.1 of AS/NZS2918;2018. The level of fuel was maintained between 50-75% of the full volume level of the fuel chamber during the High Fire test.

The average fuel load for initiating the High Fire tests was 12.9kg with an average refuelling rate of 2.7kg/10 minutes.

During High Fire testing it was found that the highest surface temperatures occurred when the primary air control and the damper of the appliance was fully open.

#### **5.2 Flash Fire Test**

Immediately after the High Fire test was completed, sufficient embers were removed to bring the fire bed to a level of 15-25% of the fuel chamber volume. The appliance was then fired in accordance with Section B9.2 of AS/NZS2918;2018.

The average fuel load for initiating the Flash Fire tests was 10.7kg.

The highest temperature rises were achieved by leaving the main door raised open 40mm with the primary air and damper fully open.

### 5.3 Ambient and Test Surface Temperatures

The Tables below show the Ambient temperatures and test surfaces temperatures during testing of the appliance and flue combination:

#### *Ambient Temperature Range °C*

Position	High Fire	Flash Fire
A	10.0 – 27.6	20.8 – 28.8
B	19.2 – 28.1	17.0 – 27.0

#### *Maximum Surface Temperature Rise above Ambient - Position A*

Position	Thermocouple Number	High Fire Test (°C)	Thermocouple Number	Flash Fire Test (°C)
Floor	7	54.9	16	65.7
Ceiling	20	57.8	19	67.2
Rear Wall	29	62.9	29	81.8
Side Wall	26	59.8	26	52.7

#### *Maximum Surface Temperature Rise above Ambient - Position B*

Position	Thermocouple Number	High Fire Test (°C)	Thermocouple Number	Flash Fire Test (°C)
Ceiling	20	55.1	20	63.8
RHS Wall	26	62.8	26	82.4
LHS Wall	29	62.1	29	73.7

### 5.4 Uncertainty of Measurement Statement

5.5.1 The uncertainty of distance measurement for determining clearance distances was not greater than  $\pm 3$ mm.

5.5.2 The uncertainty of temperature measurement during the entire test period was a maximum of  $\pm 2^\circ\text{C}$  at a 95% confidence level.

## 6. APPLIANCE CONSTRUCTION DETAILS

The test results reported directly relate to the appliance/flue system tested. The details of the appliance given in this section include features which may affect safety clearances. Any change in the design/construction of this appliance or flue may invalidate this report. Below are the constructions details of the appliance:

Appliance Model Name: <b>Domina SW-1120</b>		Serial No: <b>N/A</b>
Manufacturer: <b>Schots Home Emporium</b>		
Overall Height: <b>1152mm</b>	Overall Depth: <b>550mm</b>	Overall Width: <b>1072mm</b>
Top Plate Width: <b>1072mm</b>	Top Plate Depth: <b>520mm</b>	Top Plate Thickness: <b>1.2mm</b>
Usable Firebox Height: <b>370mm</b>	Width: <b>820mm</b>	Depth: <b>310mm</b>
Usable Firebox Volume: <b>94.05 Litres</b>		
Firebox Material Type/Seam Fully Welded: <b>Fully welded 3mm steel</b>		
Firebrick Type: <b>40mm Vermiculite sides and rear, 50mm base</b>		
Main Door Opening Height: <b>325mm</b>	Width: <b>774mm</b>	
Door Height: <b>438mm</b>	Width: <b>845mm</b>	Depth: <b>38mm</b>
Door glass Height: <b>418mm</b>	Width: <b>833mm</b>	
Primary Air Location: <b>Below grate</b>		
Dimension of Primary Air: <b>1 slot 400mm wide × 28mm high with 10mm slide travel, zero when closed</b>		
Area of Primary (mm <sup>2</sup> ): <b>8,560mm<sup>2</sup></b>		
Secondary/Tertiary Air Location: <b>Rear of firebox, 75-95mm below baffle</b>		
Dimension of Secondary/Tertiary Air: <b>10 holes @ 15mm</b>		
Area of Secondary/Tertiary Air (mm <sup>2</sup> ): <b>1,767.4mm<sup>2</sup></b>		
Baffle Plate size: <b>800×225×30mm</b>		
Damper: <b>185mm diameter, 2mm thick</b>		
Flue Dimensions: <b>200mm</b>		
Spigot Dimensions:	OD: <b>204mm</b>	ID: <b>200mm</b>
Spigot to Rear of Appliance: <b>145mm</b>		
Rear Internal to External Heat Shield: <b>N/A</b>		
Firebox to Side External Heat Shield: <b>N/A</b>		
Heat Shield Material Type: <b>N/A</b>		
Water Heater Fitted: <b>No</b>		
Fan Location/Speeds: <b>N/A</b>		
Catalytic Combustor fitted: <b>No</b>		
Grate: <b>Yes</b>		
<b>NOTE: Accuracy of measurement is ±5% of the measured value</b>		

## 7. CONCLUSION

The Domina SW-1120 Free-standing appliance installed with a Flo-met SG-FLKIT 200-FS-B Flue Kit, conforms to the requirements of Australian/New Zealand Standard 2918:2018, with respect to floor, ceiling, side wall and rear wall surface temperatures, when tested in the test positions shown in Figure 1 of this report in accordance with Appendix B of AS/NZS2918:2018.





## APPENDIX 1:

**Flue kit – 8" stainless steel active with 10" painted casing below ceiling. 10 & 12" galvanized casings above the ceiling**

