



3 Garden Street, Morwell Vic 3840
ABN: 46 610 154 768

PREPARED FOR

SCHOTS HOME EMPORIUM



THERMAL CLEARANCE TESTING OF THE DOMINA FREE-STANDING APPLIANCE

Report Number: ASFT21010-1
Issue date: 24 March 2021

By:
Garry Wayne Mooney



Accredited for compliance with ISO/IEC 17025 - Testing
The results of the tests, calibrations and/ or measurements included
in this document are traceable to Australian/National Standards

Accreditation # 20042

Report Distribution

Schots Home Emporium

400 Hoddle Street
Clifton Hill VIC 3068

Mr Don Savige

ASFT Report Archive

Revision Details

Revision	Date	Comments
0	4/03/2021	Preliminary report – awaiting payment and engineering drawings of appliance
1	24/03/2021	Issue of NATA endorsed test report

Disclaimer

This Report is intended only for the use of the individual or entity named above (Intended Recipient). ASFT is not liable to the Intended Recipient in respect of any loss, damage, cost or expense suffered as a result of reliance on the information contained in this Report or any actions taken or not taken on the basis of this Report. In particular, results presented in this Report relate exclusively to the samples selected by the Intended Recipient and no responsibility is taken for the representativeness of these samples.

This report shall not be reproduced except in full, without written approval of ASFT.

QD-001R1

Copyright © 2021 ASFT

THERMAL CLEARANCE TESTING OF THE DOMINA FREE-STANDING APPLIANCE

Report

The Domina Free-standing appliance installed with a Flo-met SG-FLKIT 200-FS-B Flue Kit was tested in two positions in a manner conforming to joint Australian/New Zealand Standard 2918:2018, Appendix B.

A minimum 1,400mm deep x 1,090mm wide x 50mm thick floor protector (compressed board) should be used under and in front of the appliance base when installing the appliance (see joint AS/NZS 2918:2018 3.3.2). The floor protector should extend 850mm in front of the appliance door and be placed centrally in the 1,090mm width. The Thermal resistivity of the floor protector is 0.22m².K/W for 50mm thick compressed board sheets.

The flue system must incorporate an additional 900mm long, 13" galvanized piece flue casing above the ceiling from the ceiling ring and a minimum 25mm clearance around the flue outer casing to any combustible material at the ceiling penetration.

The Domina Free-Standing solid fuel appliance installed with a Flo-met SG-FLKIT 200-FS-B Flue Kit conforms to the requirements of the joint AS/NZS 2918:2018 Standard, Appendix B.

The appliance and flue system were tested at the following clearances;

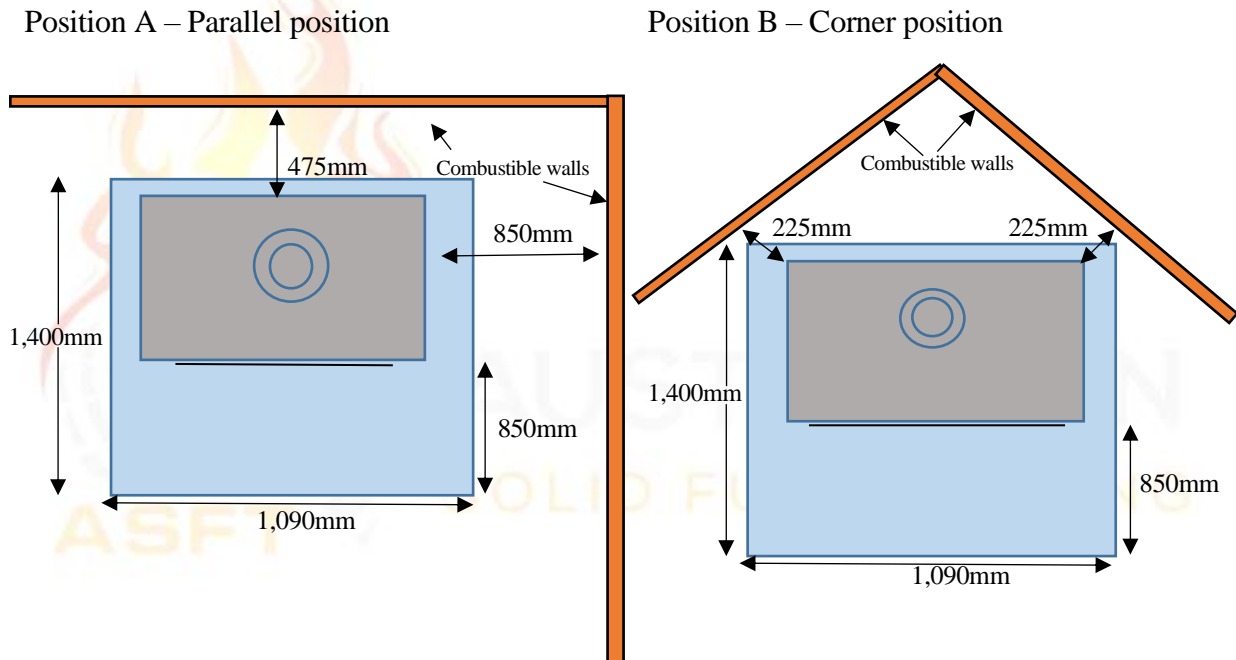

Figure 1 – Clearance Diagram

Signed		Approved	
Name	Garry W. Mooney	Name	Steve Marland
Title	Technical Officer	Title	Managing Director – Australian Solid Fuel Testing
Date	24/03/2021	Date	24/03/2021

1. INTRODUCTION

Thermal Clearance testing of the Domina appliance and flue system took place on 1 and 2 March 2021 at the Australian Solid Fuel Testing Laboratory located at 3 Garden Street, Morwell, Victoria. The testing was performed by Mr G.W. Mooney and Mr S. Marland.

2. PROCEDURE

Testing was conducted as per Appendix B of AS/NZS2918;2018, Hot sites were located with the aid of an infra-red thermometer. Thermocouple tips were stapled onto the test surfaces, with black tape over the first 100 mm to facilitate consistent and accurate recording of temperatures.

Thermocouple positions are shown in the table below:

Position A – Parallel Position

Thermocouple No.	Position	Thermocouple No.	Position
1	Floor - 1300mm in front of centre	16	Floor – 150mm RHS of centre
2	Floor – 1200mm in front of centre	17	Floor – 300mm RHS of centre
3	Floor - 1050mm in front of centre	18	Floor – 450mm RHS of centre
4	Floor – 900mm in front of centre	19	Ceiling Ring – Inner front
5	Floor – 750mm in front of centre	20	Ceiling Ring – 25mm in front
6	Floor – 600mm in front of centre	21	Ceiling Ring – Inner side
7	Floor – 450mm in front of centre	22	Ceiling Ring – 25mm to side
8	Floor – 300mm in front of centre	23	Rear wall – 1322mm from corner, 1864mm above the floor
9	Floor – 150mm in front of centre	24	Rear wall – 1315mm from corner, 1358mm above the floor
10	Floor – Centre of flue	25	Rear wall – 716mm from corner, 513mm above the floor
11	Floor – 150mm behind centre	26	RHS wall, 1372mm from corner, 576mm above the floor
12	Floor – 300mm behind centre	27	RHS wall, 330mm from corner, 1813mm above the floor
13	Floor – 450mm LHS of centre	28	RHS wall, 1493mm from corner, 553mm above the floor
14	Floor – 300mm LHS of centre	29	Rear wall – 1161mm from corner, 1280mm above the floor
15	Floor – 150mm LHS of centre	30	Ambient temperature

Position B – Corner Position

Thermocouple No.	Position	Thermocouple No.	Position
19	Ceiling Ring – Inner front	25	LHS wall – 716mm from corner, 513mm above the floor
20	Ceiling Ring – 25mm in front	26	RHS wall, 794mm from corner, 1468mm above the floor
21	Ceiling Ring – Inner side	27	RHS wall, 762mm from corner, 1818mm above the floor
22	Ceiling Ring – 25mm to side	28	RHS wall, 449mm from corner, 1261mm above the floor
23	LHS wall – 878mm from corner, 1823mm above the floor	29	LHS wall, 1157mm from corner, 1275mm above the floor
24	LHS wall – 718mm from corner, 1478mm above the floor	30	Ambient temperature

TABLE 1

3. TEST FUEL

Testing was conducted with Pinus Radiata as the test fuel which had a moisture content of 11.1% moisture. Each firewood piece was 300mm x 100mm x 40mm.

4. FLUE SYSTEM

The flue system used during testing was a Flo-met SG-FLKIT 200-FS-B Flue Kit incorporating a 515mm ceiling ring with a 15mm air gap between the ceiling and the ceiling ring which was manufactured by Floate Metal Fabrications Pty Ltd. This flue kit used a Solid Painted casing above the appliance. This flue system has not been tested to joint AS/NZS 2918:2018, Appendix F. The flue height was 4.6 ± 0.1 m from the floor protector. Appendix 1 shows details of the flue system.

5. RESULTS

5.1 High Fire Test

The appliance was fired in accordance with Section B9.1 of AS/NZS2918;2018. The level of fuel was maintained between 50-75% of the full volume level of the fuel chamber during the High Fire test.

The average fuel load for initiating the High Fire tests was 16.2kg with an average refuelling rate of 2.4kg/10 minutes.

During High Fire testing it was found that the highest surface temperatures occurred when the primary air control and the damper of the appliance was fully open.

5.2 Flash Fire Test

Immediately after the High Fire test was completed, sufficient embers were removed to bring the fire bed to a level of 15-25% of the fuel chamber volume. The appliance was then fired in accordance with Section B9.2 of AS/NZS2918;2018.

The average fuel load for initiating the Flash Fire tests was 13.4kg.

The highest temperature rises were achieved by leaving the main door raised open 20mm with the primary air and damper fully open.

5.3 Ambient and Test Surface Temperatures

The Tables below show the Ambient temperatures and test surfaces temperatures during testing of the appliance and flue combination:

Ambient Temperature Range °C

Position	High Fire	Flash Fire
A	10.3 – 22.3	17.8 – 26.1
B	16.2 – 23.3	17.9 – 23.4

Maximum Surface Temperature Rise above Ambient - Position A

Position	Thermocouple Number	High Fire Test (°C)	Thermocouple Number	Flash Fire Test (°C)
Floor	5	64.0	1	68.9
Ceiling	20	54.4	19	81.2
Rear Wall	29	60.5	29	82.9
Side Wall	28	58.6	28	59.4

Maximum Surface Temperature Rise above Ambient - Position B

Position	Thermocouple Number	High Fire Test (°C)	Thermocouple Number	Flash Fire Test (°C)
Ceiling	20	60.1	19	83.0
RHS Wall	26	59.7	26	81.3
LHS Wall	29	57.0	29	75.5

5.4 Uncertainty of Measurement Statement

5.5.1 The uncertainty of distance measurement for determining clearance distances was not greater than ± 3 mm.

5.5.2 The uncertainty of temperature measurement during the entire test period was a maximum of $\pm 2^\circ\text{C}$ at a 95% confidence level.

6. APPLIANCE CONSTRUCTION DETAILS

The test results reported directly relate to the appliance/flue system tested. The details of the appliance given in this section include features which may affect safety clearances. Any change in the design/construction of this appliance or flue may invalidate this report. Below are the constructions details of the appliance:

Appliance Model Name: Domina		Serial No: N/A
Manufacturer: Schots Home Emporium		
Overall Height: 1537mm	Overall Depth: 550mm	Overall Width: 990mm
Top Plate Width: 987mm	Top Plate Depth: 518mm	Top Plate Thickness: 1.2mm
Usable Firebox Height: 560mm	Width: 737mm	Depth: 298mm
Usable Firebox Volume: 122.99 Litres		
Firebox Material Type/Seam Fully Welded: Fully welded 3mm steel		
Firebrick Type: 40mm Vermiculite sides and rear, 50mm vermiculite on base		
Main Door Opening Height: 458mm	Width: 690mm	
Door Height: 645mm	Width: 755mm	Depth: 35mm
Door glass Height: 627mm	Width: 750mm	
Primary Air Location: Below grate		
Dimension of Primary Air: 290×15mm, zero when fully closed		
Area of Primary (mm ²): 4,350mm²		
Secondary/Tertiary Air Location: Rear of firebox 225-245mm below baffle		
Dimension of Secondary/Tertiary Air: 8 holes @ 16mm		
Area of Secondary/Tertiary Air (mm ²): 1,608.7mm²		
Baffle Plate size: 715×225×30mm Vermiculite		
Damper: 183mm diameter, 2mm thick		
Flue Dimensions: 200mm		
Spigot Dimensions:	OD: 198mm	ID: 192mm
Spigot to Rear of Appliance: 150mm		
Rear Internal to External Heat Shield: 90mm		
Firebox to Side External Heat Shield: 80mm		
Heat Shield Material Type: 1.2mm		
Water Heater Fitted: No		
Fan Location/Speeds: N/A		
Catalytic Combustor fitted: No		
Grate: Yes		
NOTE: Accuracy of measurement is ±5% of the measured value		

7. CONCLUSION

The Domina Free-standing appliance installed with a Flo-met SG-FLKIT 200-FS-B Flue Kit, conforms to the requirements of Australian/New Zealand Standard 2918:2018, with respect to floor, ceiling, side wall and rear wall surface temperatures, when tested in the test positions shown in Figure 1 of this report in accordance with Appendix B of AS/NZS2918:2018.



APPENDIX 1:

Flue kit – 8" stainless steel active with 10" painted casing below ceiling. 10 & 12" galvanized casings above the ceiling

