



**LINEA 85 / NMV820 INBUILT
ZERO CLEARANCE BOX SUPPLEMENT INSTRUCTIONS**

**Must be used in conjunction with the Installation Manual for the
ADF LINEA 85 (NMV820) MODELS.**

Supplied by:

Castworks Pty Ltd

12a Fiveways Blvd

Keysborough VIC 3173



TESTED IN ACCORDANCE WITH AS/NZS 4013:2014 and AS/NZS 2918.

Please read this manual thoroughly before installing and starting your free-standing appliance.

Keep these instructions for future reference.



Build out dimensions and finishing shown here for builders' preparation. For the ZCB assembly, go to page 8 below.

Heater Cavity MUST BE VENTILATED.

Dimensions for Zero Clearance box:

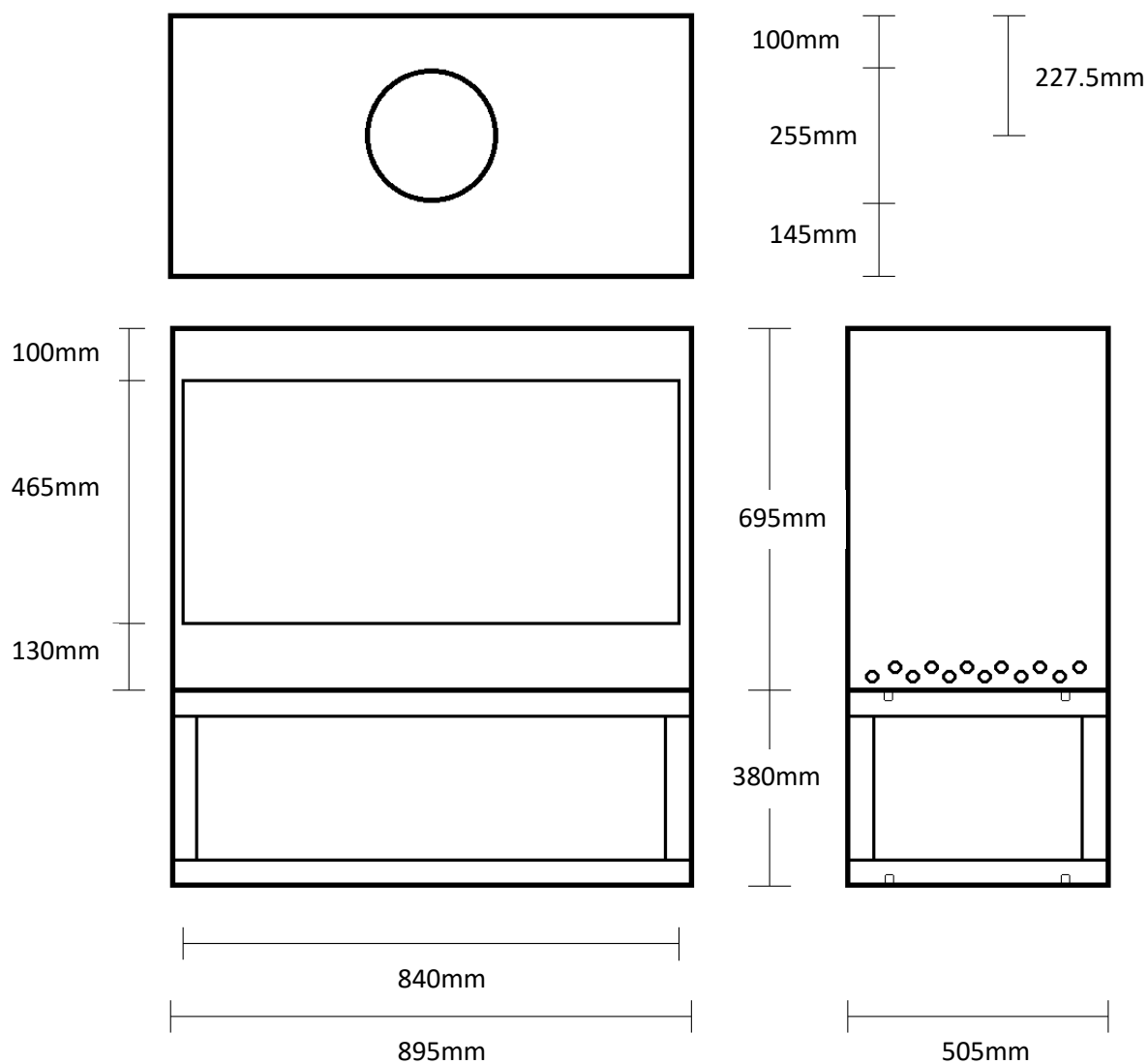

Dimensions for Build out (Front elevation):

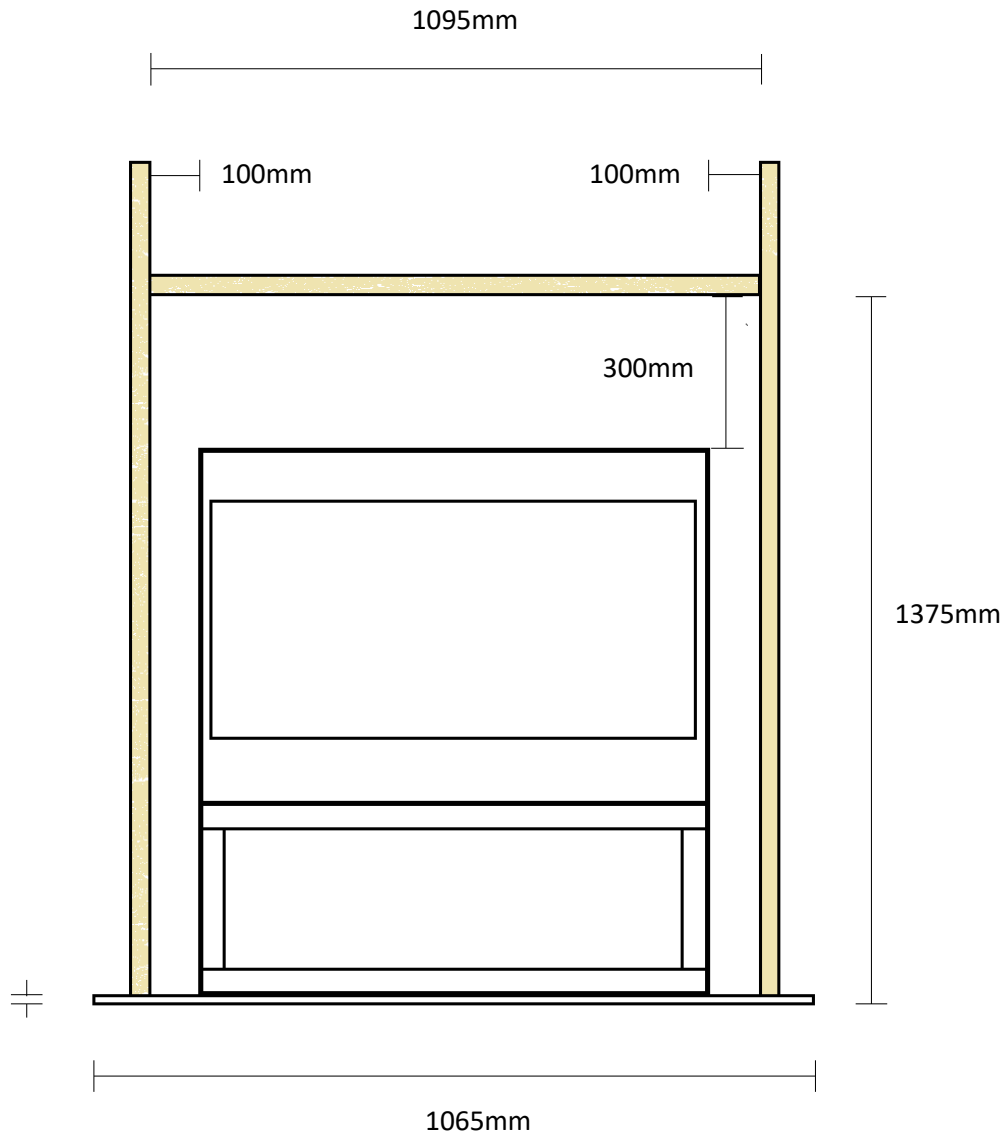

- The hearth beneath the unit must include 6mm cement sheet to 1090mm x 550mm deep. The hearth in front of the unit must include 6mm cement sheet with minimum 1065mm x 300mm deep.
- No combustibles within 300mm from the top of the Zero Clearance box (i.e., to first noggin), 100mm to each side (stud) and 50mm from the rear. No combustible material to be used in construction at all in this cavity space.
- Fan cable must be below the level of the heater base and exit the cavity below the level of the heater.

Dimensions for Build out (side Elevation):

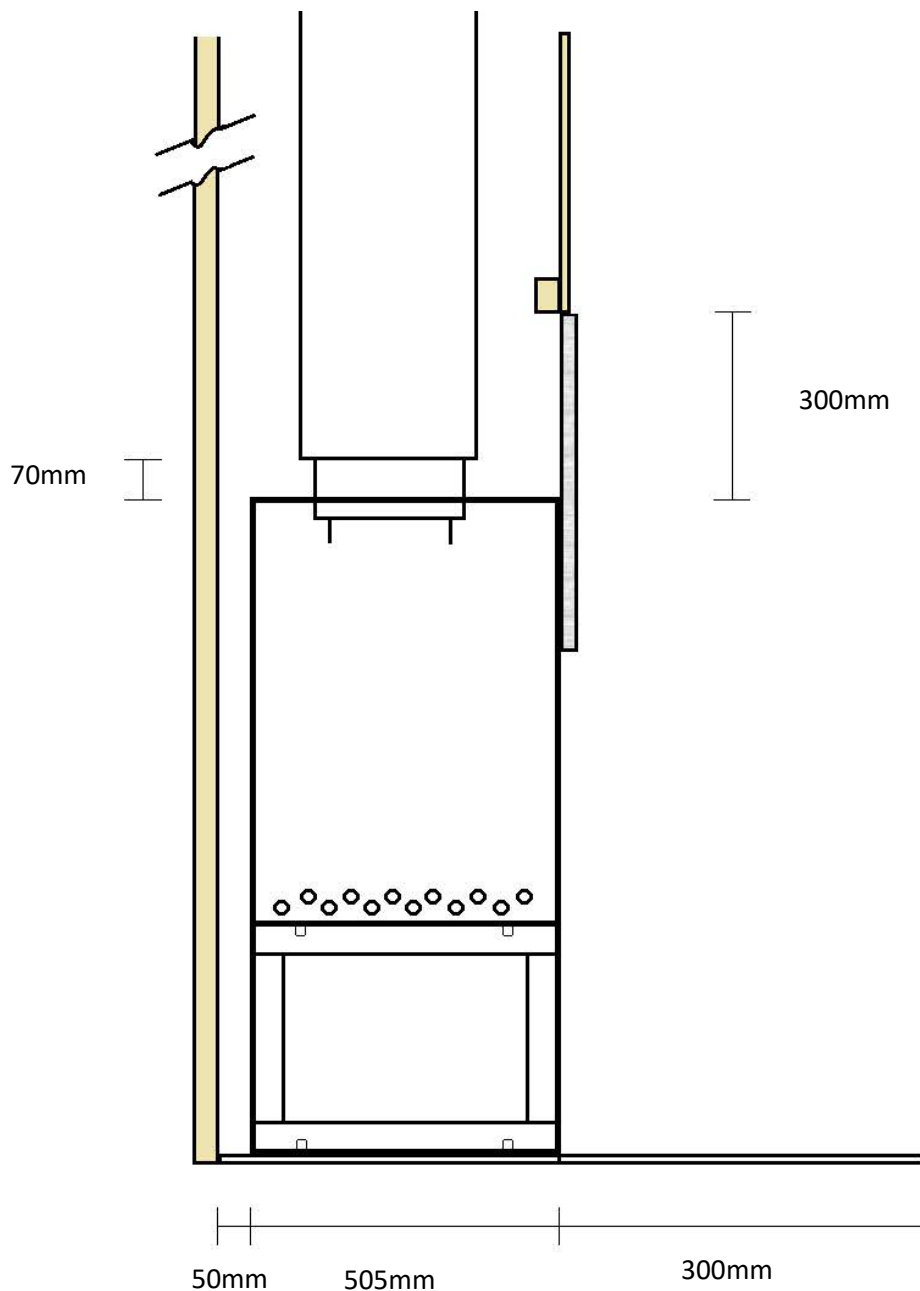

- Note Rear Clearance is 50mm to combustibles.
- 6mm cement sheet is required beneath the heater 550mm deep, and 300mm in front.
- Non-combustible board will sit in front of the Zero Clearance box. Matching to a different material may need to be packed out from the timber studs.

For any Mantle on front wall, must be to the 3.4.1.3(b) of AS/NZS 2918:2018 – ie 1000mm above the heater for combustible material.

Dimensions for Heat Resistant board:

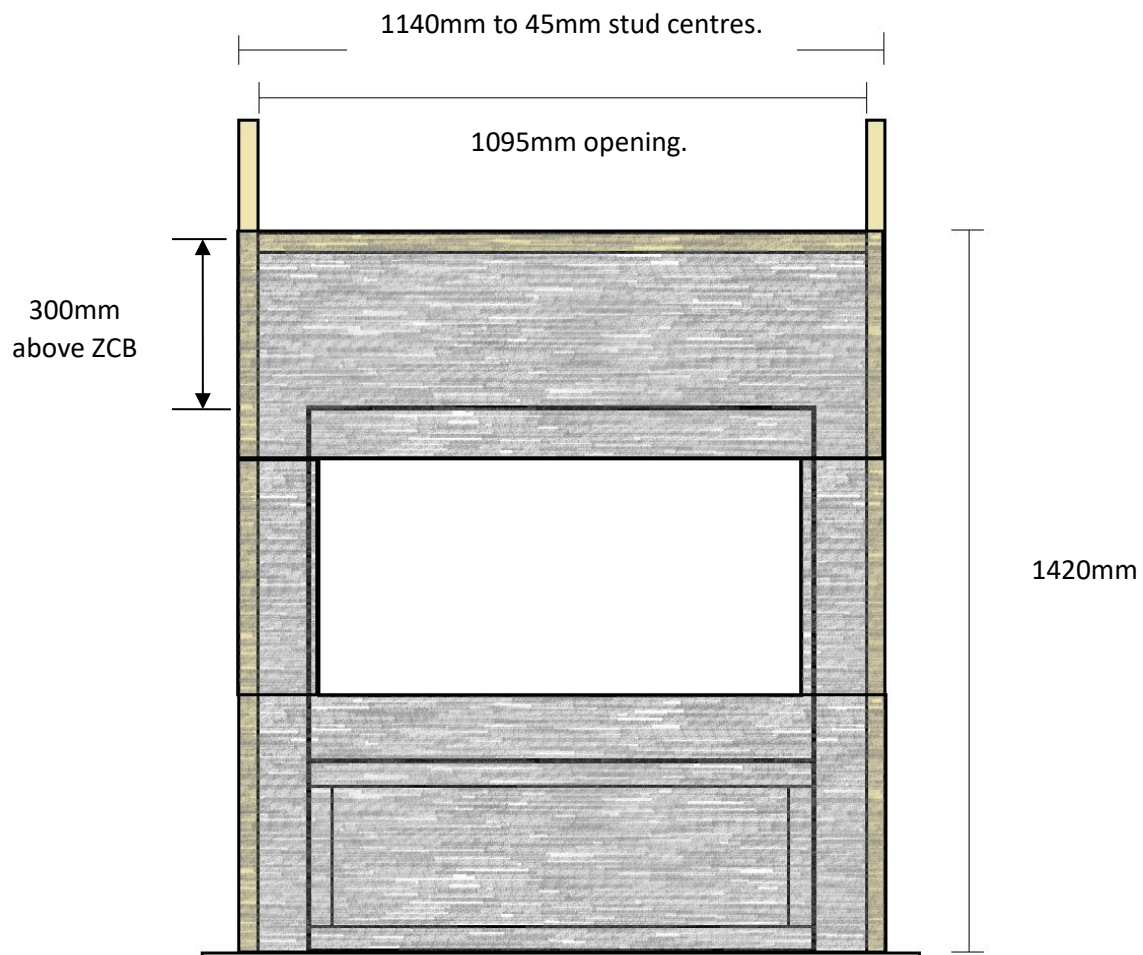

- Non Combustible Board – Fibre Cement Sheet of 18mm thick to prevent cracking, (as used in Test) or Skamol Board 40mm, required to 300mm above and 100mm each side of the heater.
- Fix with separate sheets top and bottom, and separate off cuts on each side. Use the factory cut neat edge to face the heater opening, if not covering with optional frame or tiling.

Must leave a 5mm gap between each edge of the heater and the combustible board to allow for metal expansion.

Ventilation for the Inbuilt Heater Space

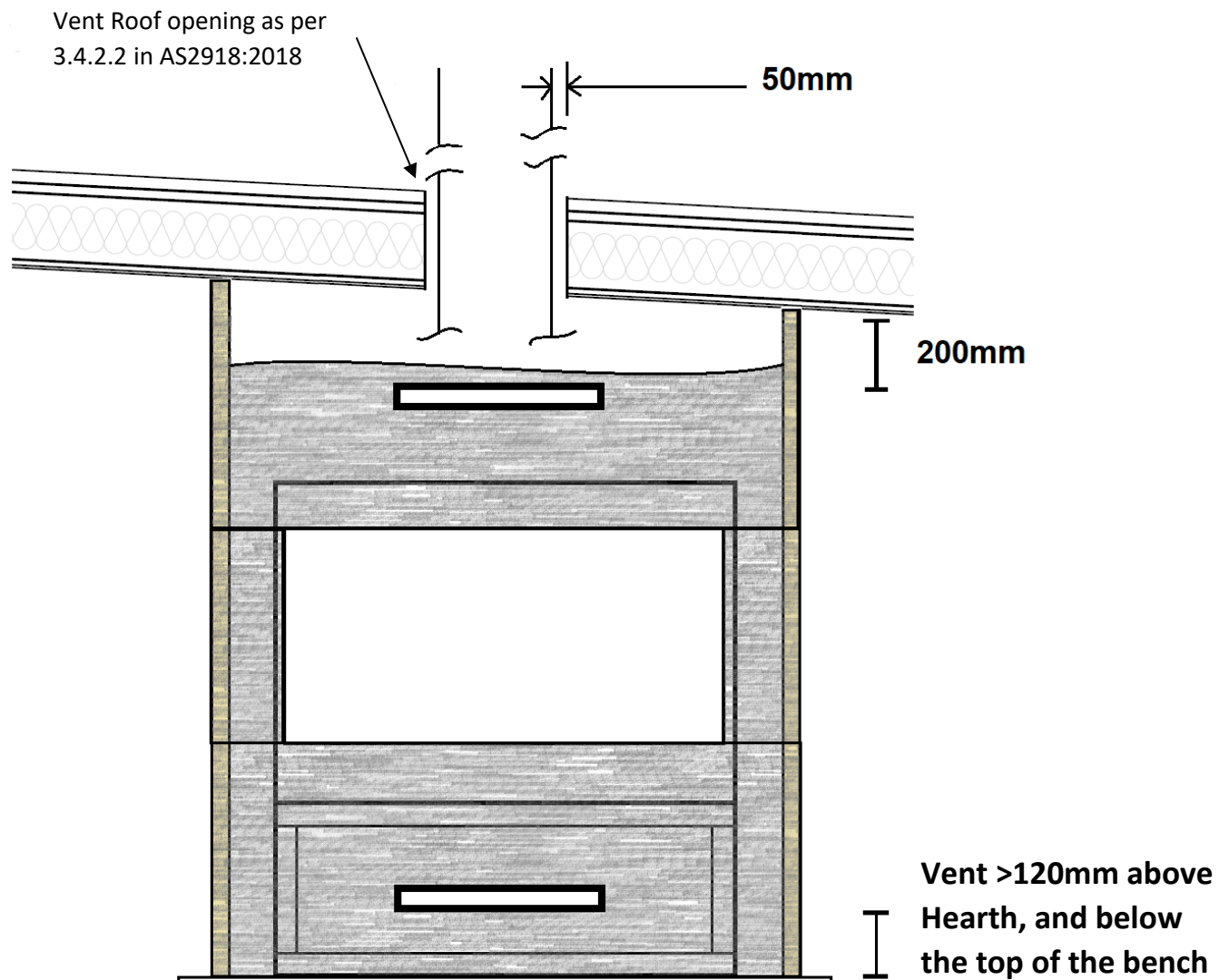

Vents included below Zero Clearance box and below Inbuilt cavity cap

- The cavity must be vented to allow air flow through the Zero Clearance Box, to keep all components and construction cool, and circulate warm air back into the room. If the cavity is capped, the vent must be below the cavity, and no restrictions to air flow.
- Gap around the flue casing and the combustible roof material is minimum 50mm. If there is no roof cavity space between the ceiling and roof, See 3.4.2.2 in AS2918:2018 for venting through roof and weather proofing. Examples shown on page 7.
- Include top and bottom vents, Minimum area 400mm x 50mm open air space vents. One at 120mm above the hearth, but below the ZCB, the second minimum 200mm below the ceiling, but 2135mm above the floor.

Venting through Sandwich Roof With Raked Ceiling When no Roof cavity available.

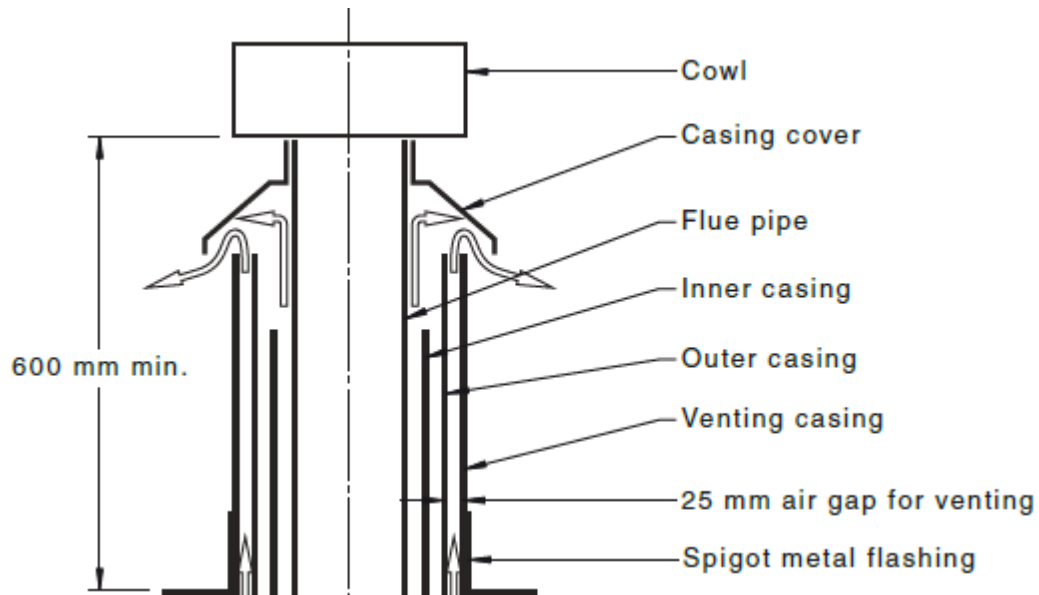

Option 1: Covered Vented Casing

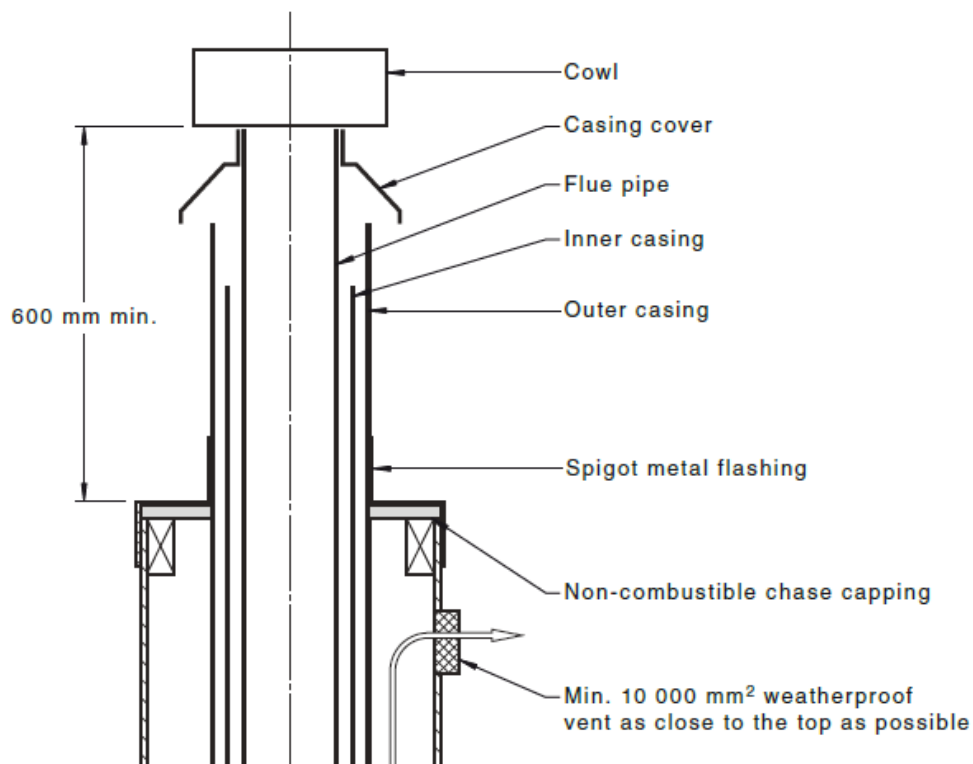

Options 2: Chimney Chase construction and side vent.

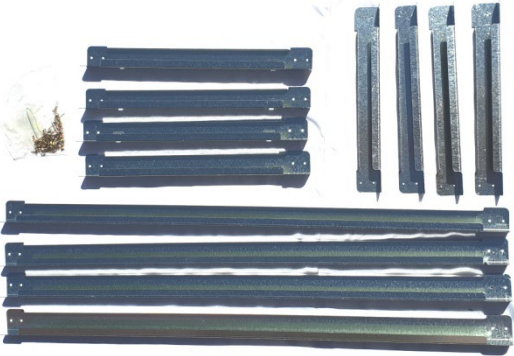
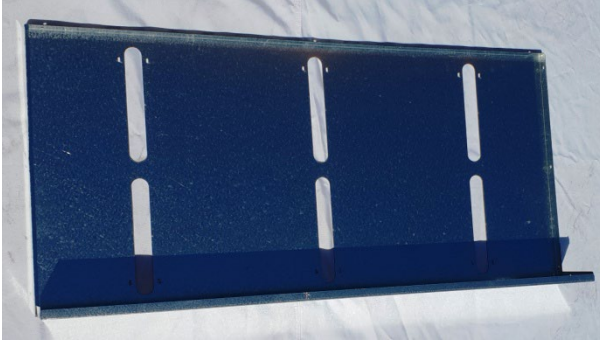

Zero Clearance Box Assembly:

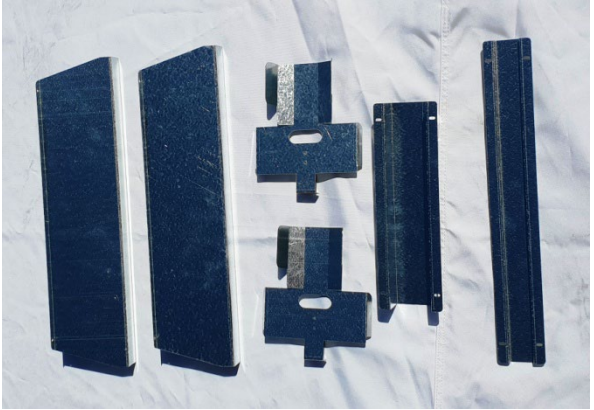
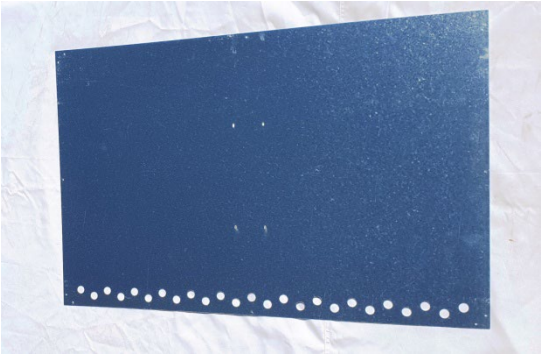
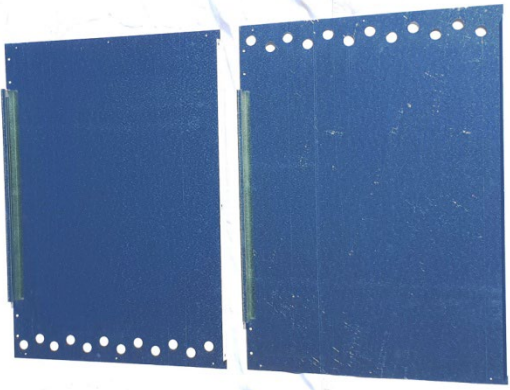
<p>ZERO CLEARANCE BOX Parts Materials list - Check all parts supplied before beginning assembly.</p>	
<p>Stand Base assembly parts, 4 Shorter Uprights, 4 Side bearers with Tabs and 4 Long Rails, Hardware kit for Assy.</p>	<p>1 x Base Panel with 6 ob-round air slots</p>
	
<p>1 x Top panel with Flue hole</p>	<p>Pictured below Left to Right: 2 x Support Rails, 2 x Flue stand off spacers, 1 x Rear spacer and 1 x Deflector for Centre air slots</p>
	
<p>1 x Back panel</p>	<p>2 x Side panels front air</p>
	

STAND ASSEMBLY

Step 1.

Assemble the Stand. Make the 2 side (or end) frames first.

For each end (side) use 2 of the Side Bearers (medium length with the cut out fold out tabs), and 2 of the shorter pieces (upstand legs). The leg has a wide fold and a smaller fold, use the wider fold so the holes align. The rails fix to the outside of the leg, the leg has the smaller holes so the rail goes on top. Fix with the 8 of the self-tapping screws.

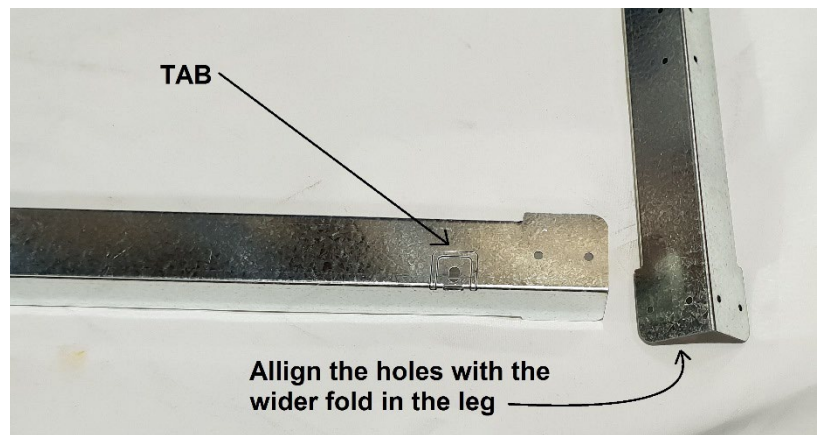
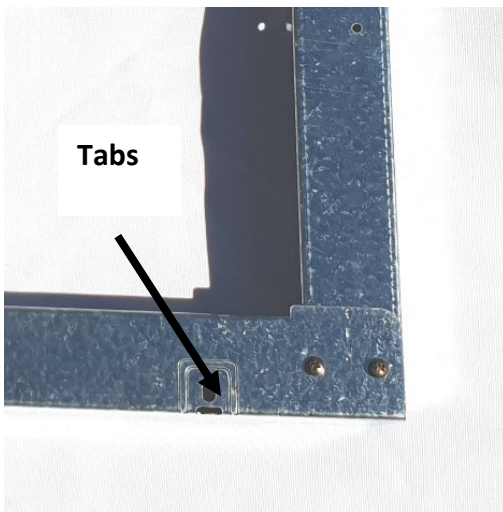

Repeat for the opposite side.

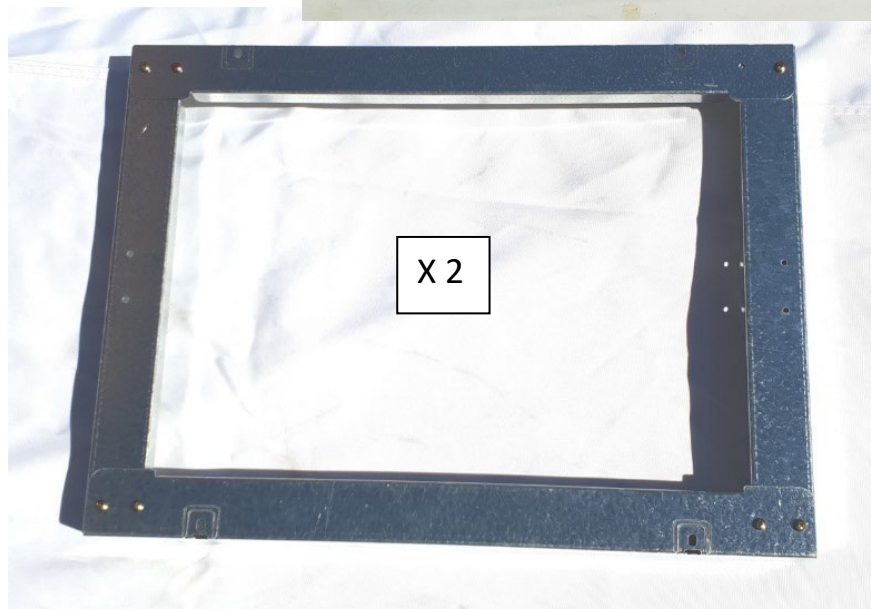

Step 2.

Join the 2 finished Rectangle side frames with the 4 long rails (left to right). Note the long rails go on the outside of the corner.



The completed assembled base, with 4 long rails joining the 2 Rectangle side frames:



Note the tabs in the base side rails can also be used to fix the frame to the floor. Ensure the base is secured to the floor, using fixings appropriate for the flooring structure.

The floor must be able to support the weight of the heater, flue and fuel load approx. 300kg

Step 3.

Screw the base panel of the Zero Clearance box to the stand base, using the self tapping machine thread screws. Then take the ZCB side panel, and put one of the screws through the side and the base panel. The side panel should be inside the base panel fold. Then slide the back panel into the inside of the base panel rear fold, and on the outside of the side panel. Add screws but don't fully tighten until the top panel is on.

Repeat for the other side panel.



NOTE: When screwing 2 panels together through the existing holes, the screw should go through the larger hole first, then through the smaller hole, and cutting the thread in the smaller hole. I.e. some holes may screw from the inside, some from the outside.

Below shows the side panels and back panel in position. Note only fully tighten all screws once the top panel is in position.

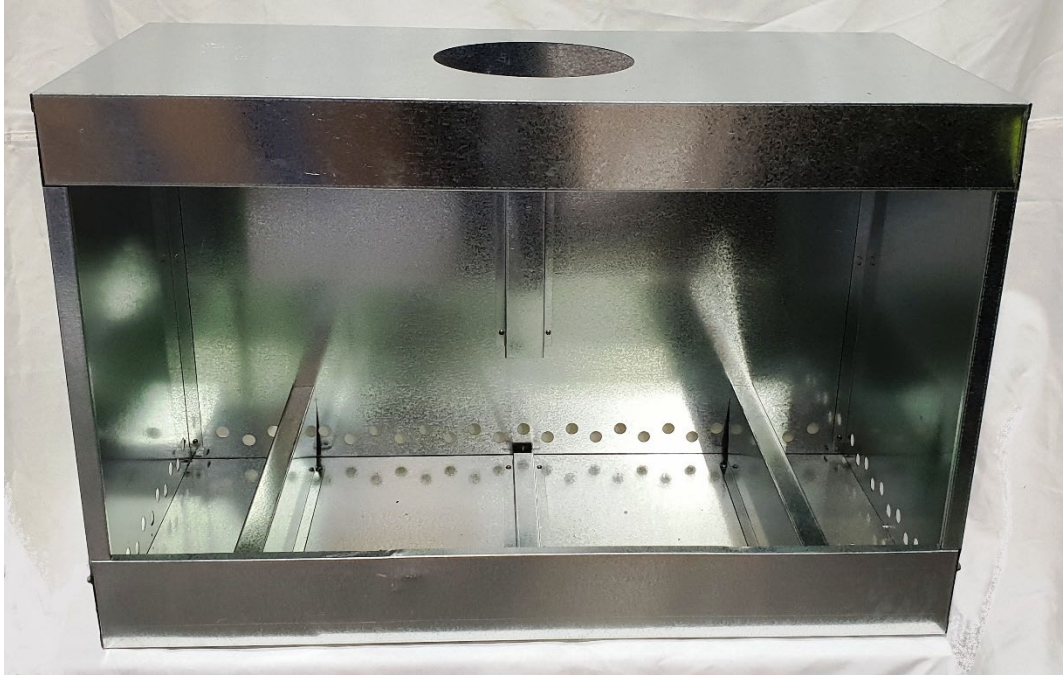

The top panel fits on, with the folds on the outside of all the other panels. Alternatively, it could be fitted on the inside of the side panels, so the holes are the same size.

Use the larger self-tapping screw for the larger holes, or create new holes with the standard screws. Once the top panel is on, tighten all of the screws.

Step 4:

Add the spacer / stopper to the back wall. So that the heater will stop when inserted up to the rear spacer.

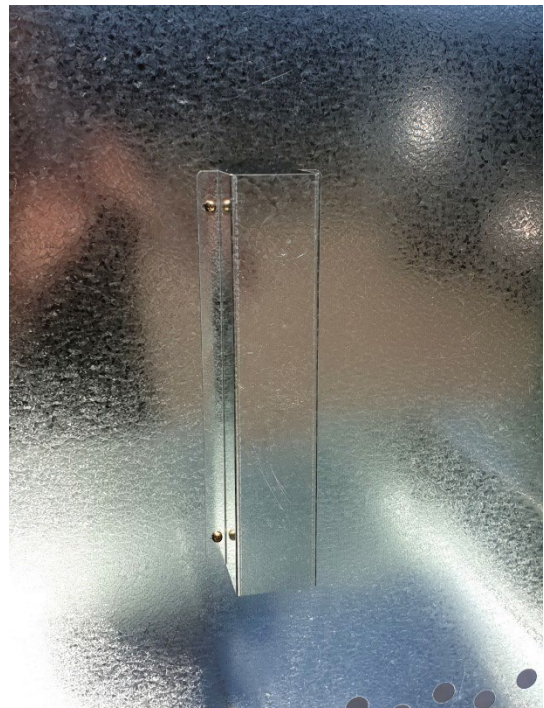

Step 5:

Add the centre deflector to the middle of the base, this allows air flow into the base, but stops radiant heat from directly hitting any combustible material below.

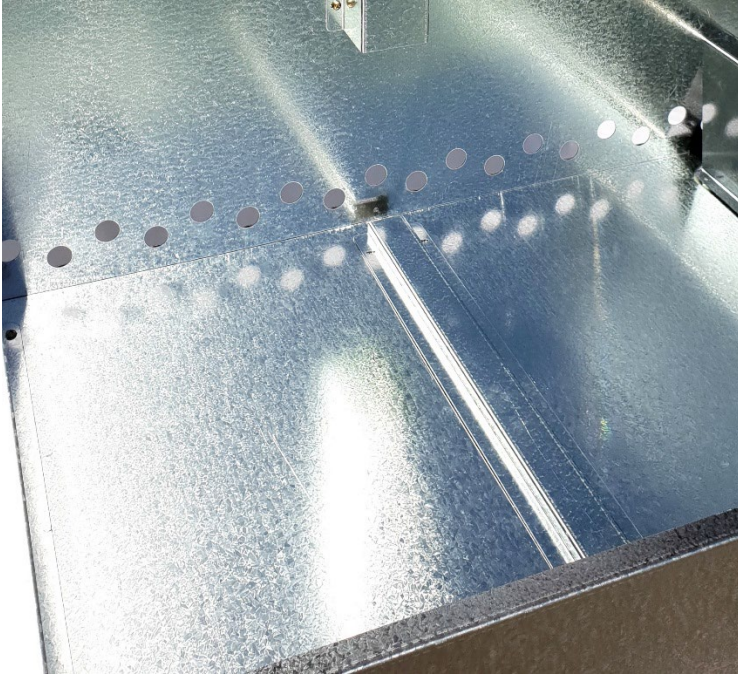
**Step 6:**

Add the Heater support rails to the base. With 4 screws each.

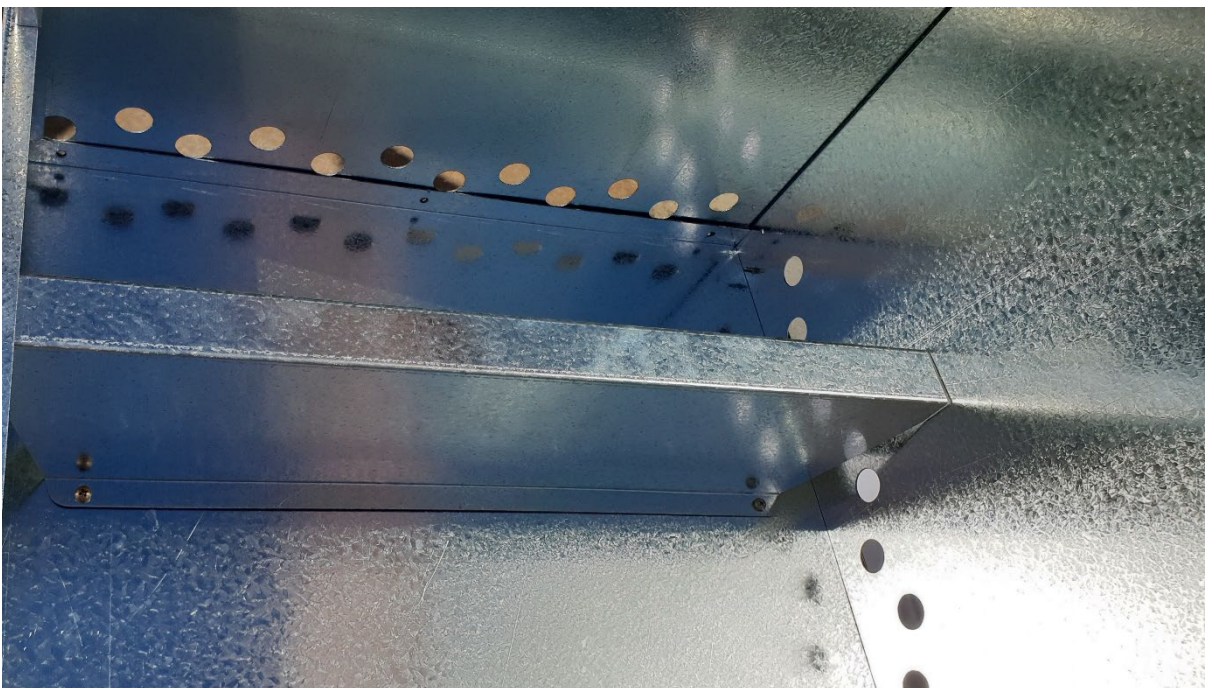

One on the left and one on the right as shown in picture:

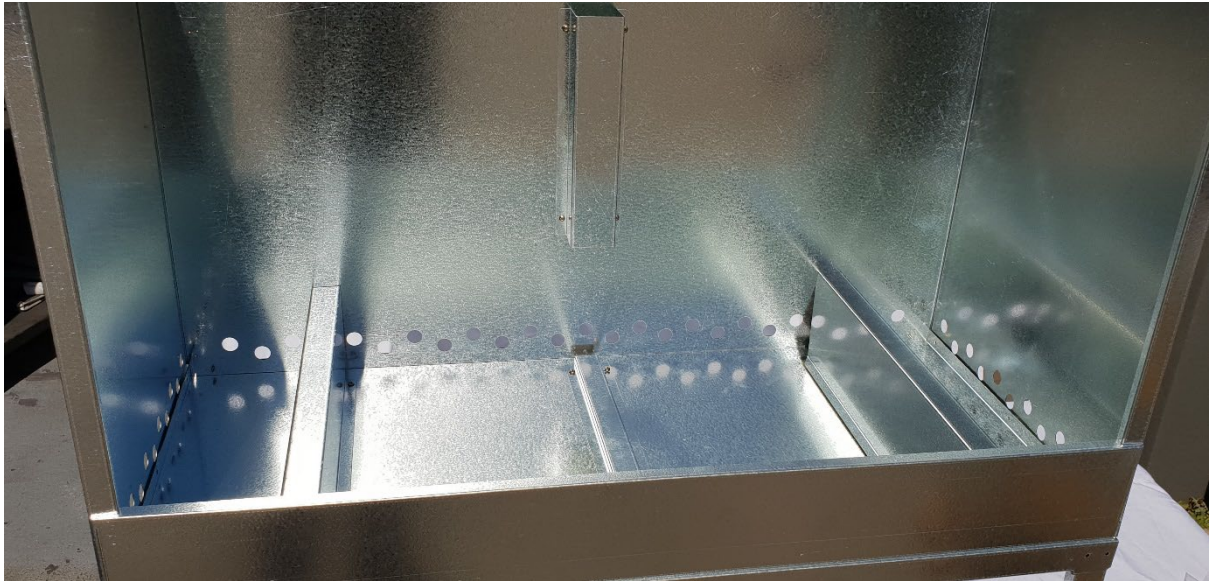

Step 7:

Fold up the tabs in the side rails and add self-tapping screw through the side, to help hold the ZCB to the stand. Use the self-drilling tapping screws to create new holes to fix. Ensure the heater is in correct position to match the build out fascia.

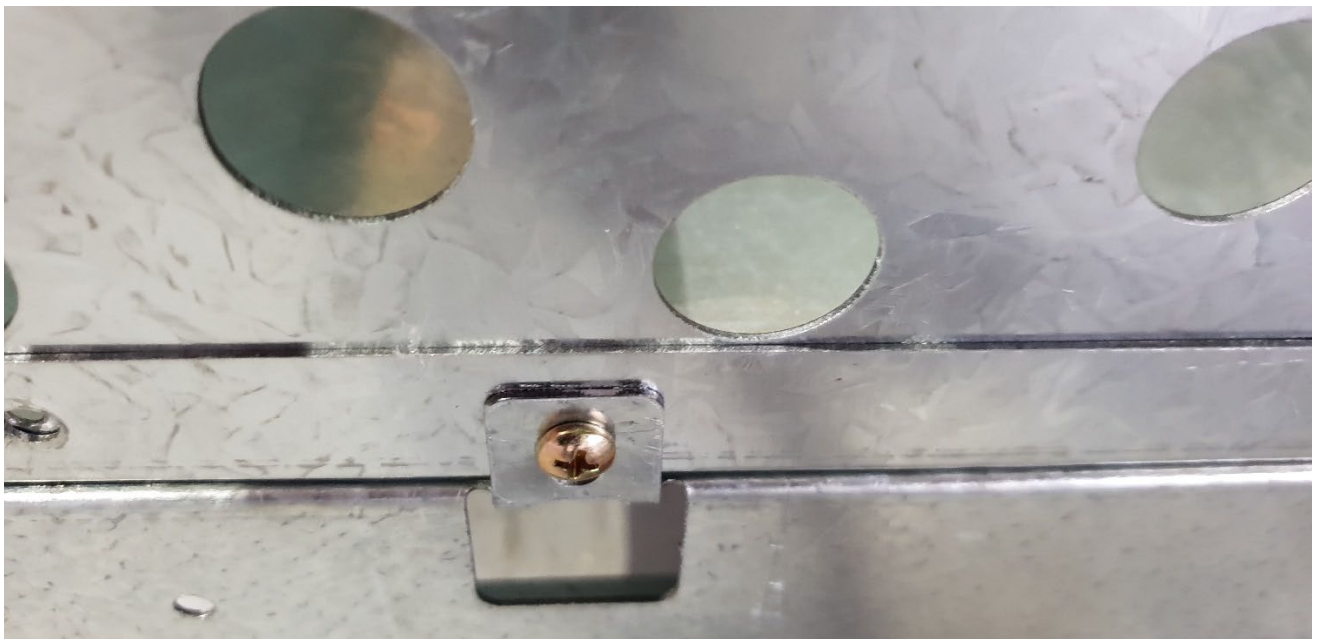

Step 8:

Fitting the Flue

The flue is raised off the top of the ZCB and the heater using these 2 brackets, orientated like below. The bottom of the bracket gets inserted into the ZCB.

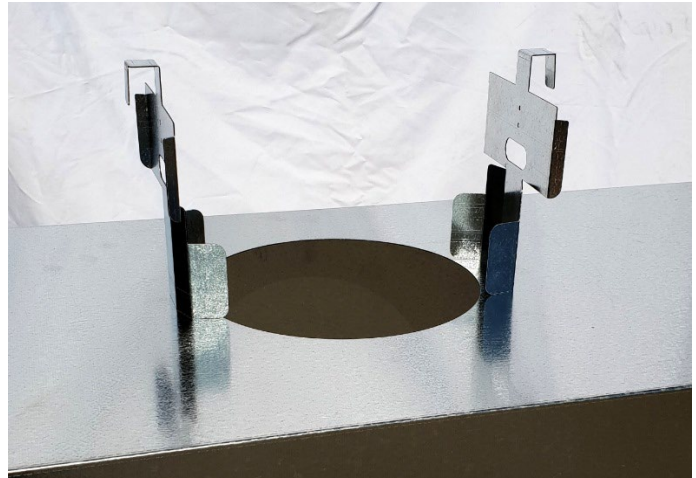

The brackets are fixed to the 10" inner casing and then the upper folded U-shaped hook is fixed to the 12" outer casing. These can be fixed with self-tapping screws or rivets.



The 10" slides through the top of the Zero Clearance Box and sits above the heater resting on the brackets. The 10" MUST be sealed with a flexible heat resistant fire cement sealant around the top of the Zero Clearance box to stop heater air coming into the chimney chase cavity.

12" MUST sit 70mm above the ZCB as shown below.

