

## WALL MOUNTED WORKBENCH STATION

### Installation Guide

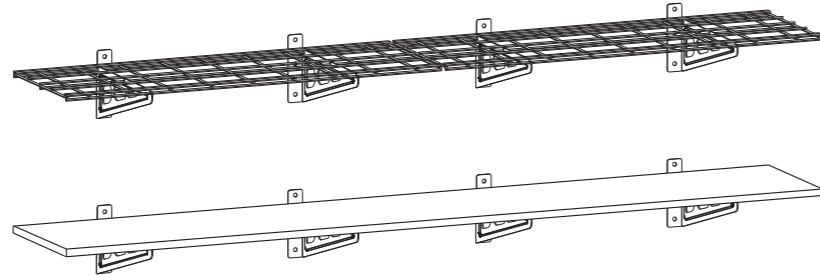

### Package Includes:

#### (A) Parts Included:

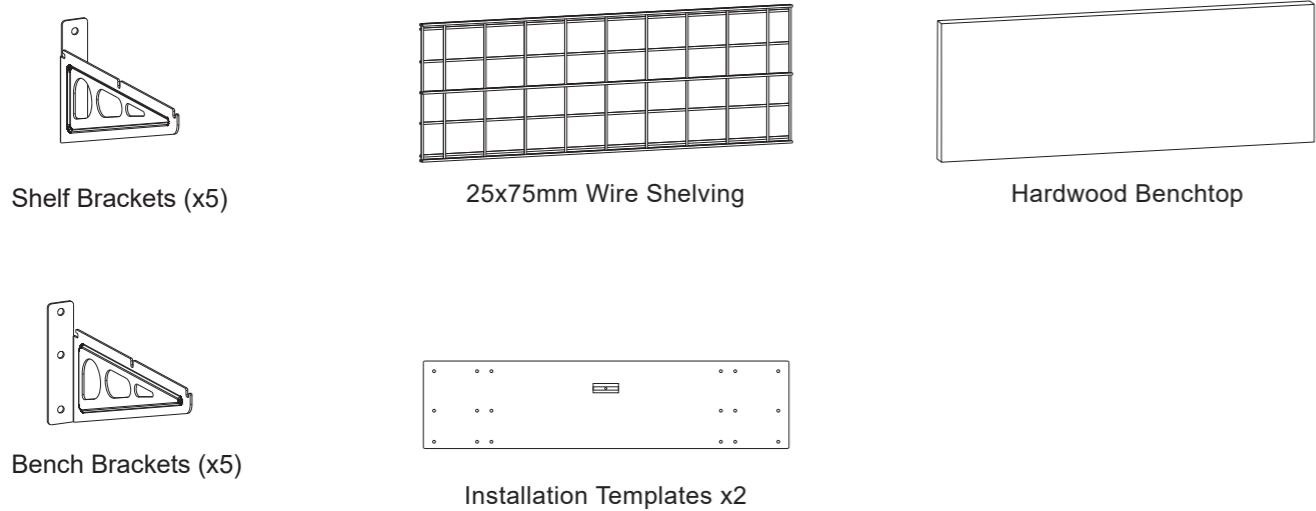

#### (B) Fixings Package



#### (C) Tools Required for Installation:

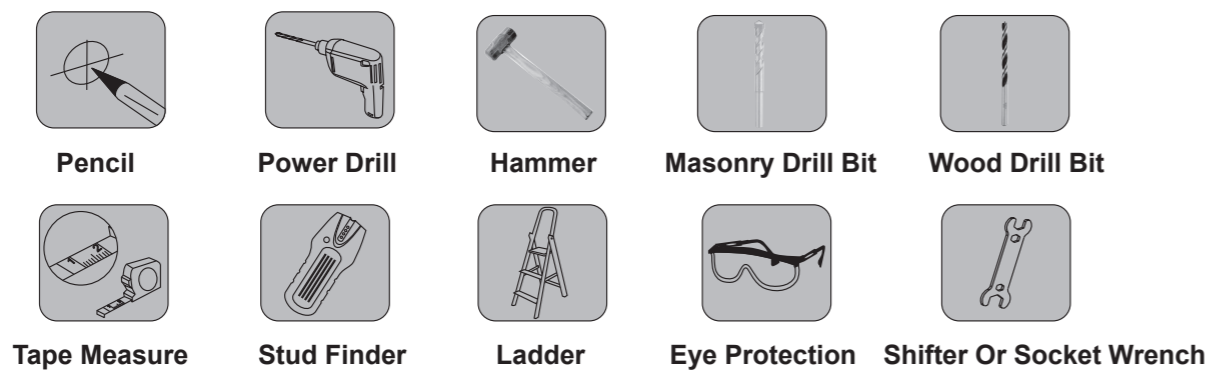

## Installation Steps:

### STEP 1-A: Install Shelf Brackets into Solid Concrete or Masonry Walls

1. Determine the desired height, use template to level and then transfer the template hole guides onto wall.
2. Drill 60mm deep holes with a 10mm masonry drill bit.
3. Hammer in the nylon anchors (B2) firstly and then install the shelf brackets with washers (B3) and coach screws (B1) with shifter or socket wrench.

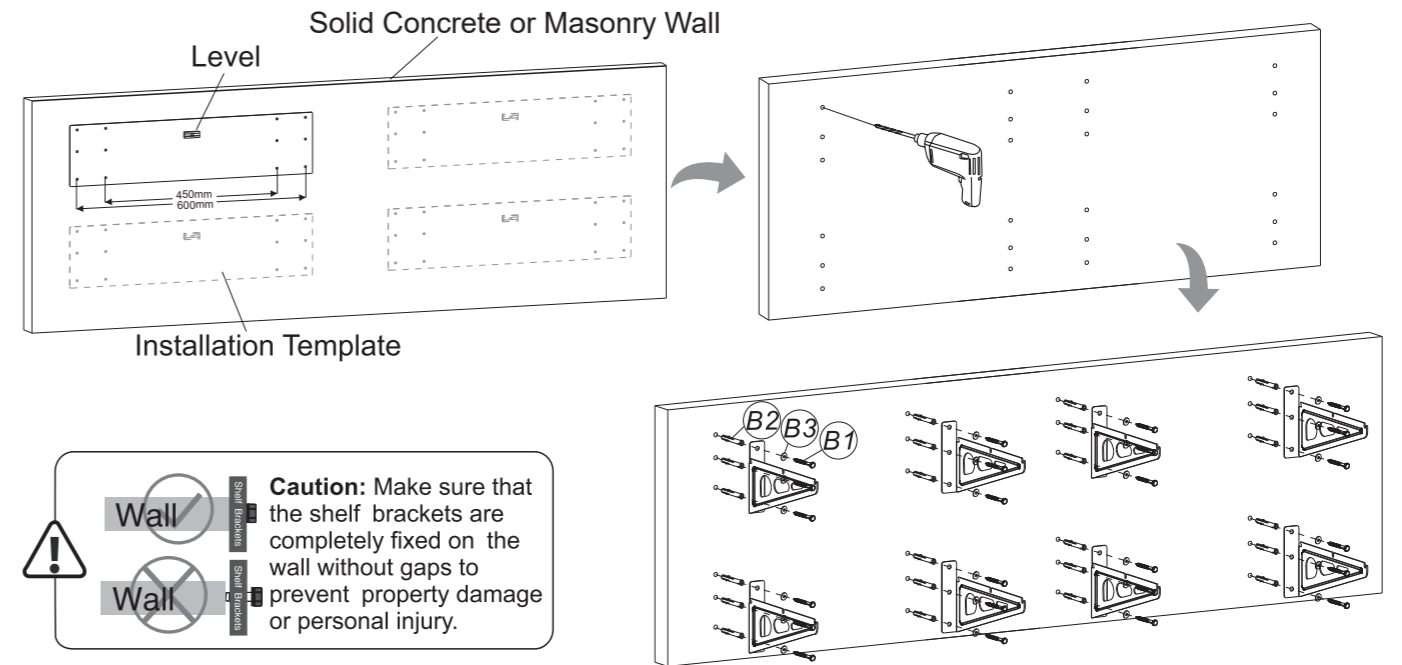
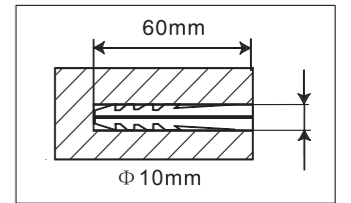

### STEP 1-B: Install Shelf Brackets into Timber Wall Studs

1. Determine the desired height, use a stud finder to ascertain stud centres ( installation template provided suits the two common stud centres being 450mm & 600mm. If for the unusual reason that stud centres are different to template centres, ensure all support brackets provided are installed onto timber wall studs )
2. Drill 60mm deep holes once template has been levelled and into position, using a 5mm wood drill bit and the holes provided on template.
3. Install the shelf brackets with washers ( B3 ) and Coach Screws ( B1 ) with a shifter or socket wrench.
4. Do not install under any circumstances onto metal stud wall frames.

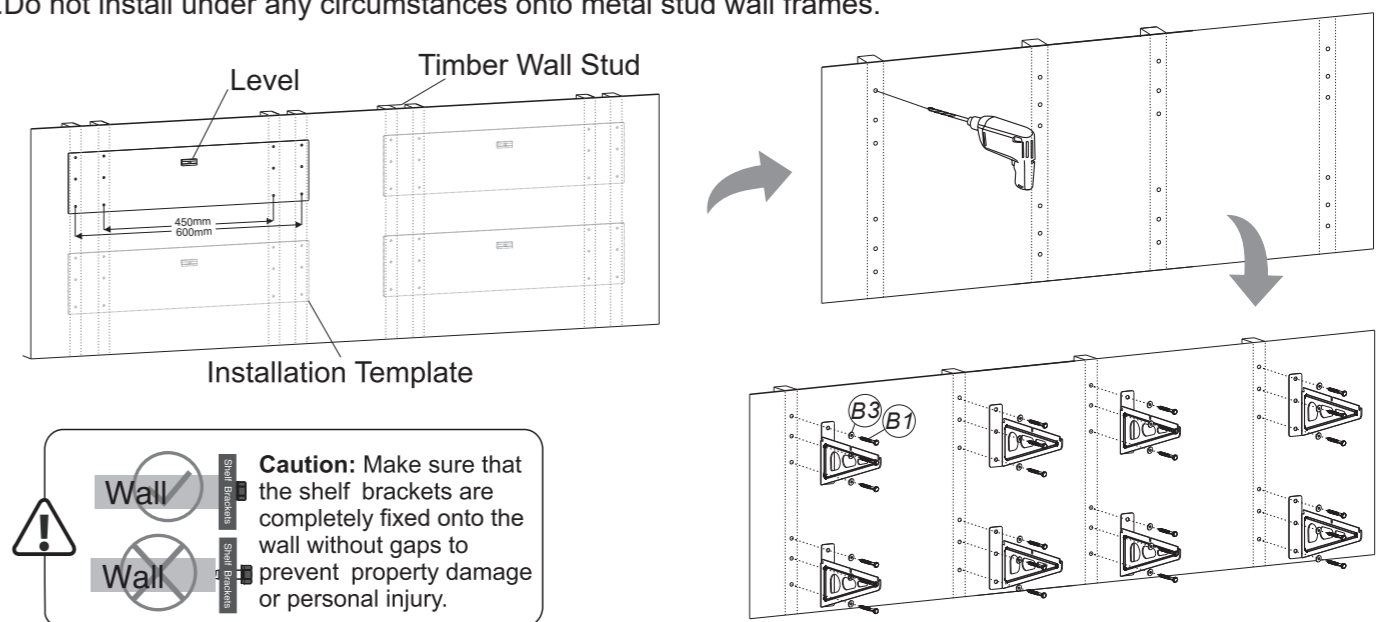
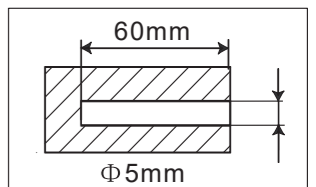

## STEP 2: Place and Attach Wire Grids

As shown in the figure secure the grid into place on the bracket, then tighten the wire and shelf brackets with the velcro at the position shown in the figure.

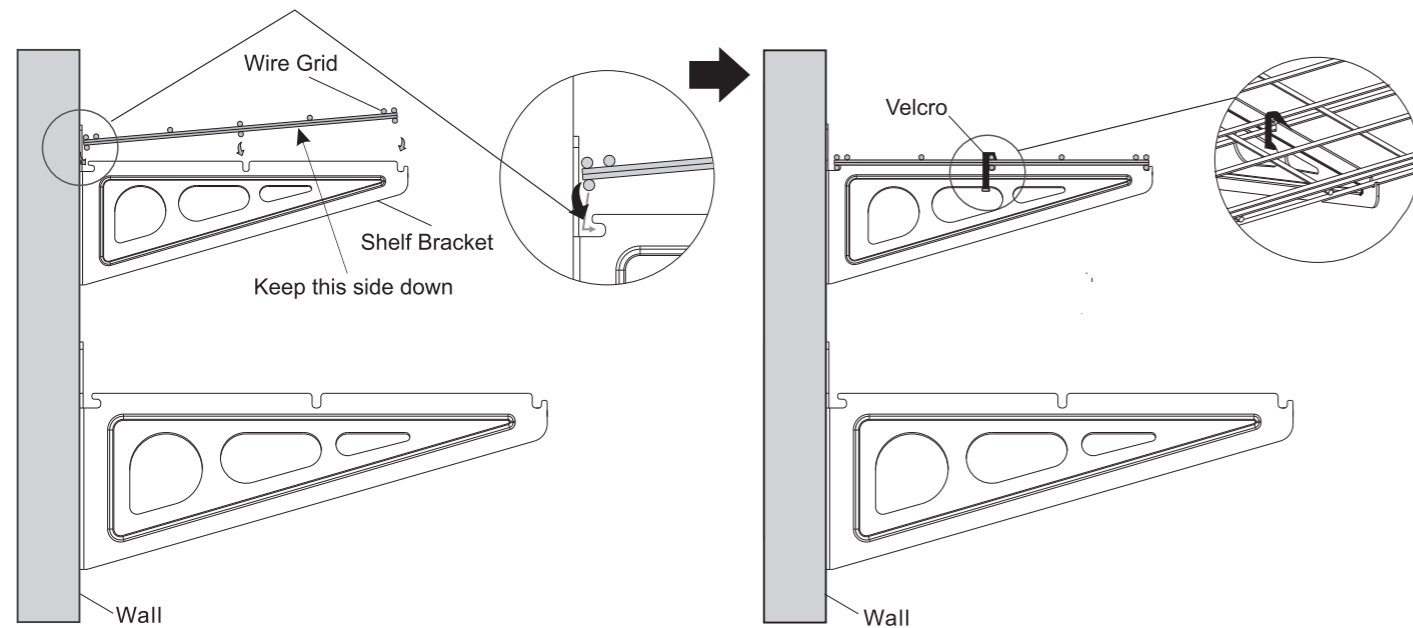

## STEP 3: Secure the Workbench



1. Place workbench onto brackets.



2. Fix the Screws into the workbench, ensuring two 20mm screws are secured per bracket (front & back).



3. Place hooks onto shelving.



4. Place items away and enjoy your new workbench station.

## ⚠ CAUTION

- This product contains small items that could be a choking hazard if swallowed, ensure that these items are kept well away from children at all times.
- Ensure that the enclosed installation manual is thoroughly read and completely understood before undertaking installation. If you are unsure nor confident about installing this product based on the information provided in the installation manual, please contact a qualified tradesperson for assistance.
- Good quality tools and safety equipment are highly recommended when installing this product.
- Prior to installation, confirm that the weight capacity of the walls substrate you are intending to install shelving onto can support the maximum load rating for this product.
- All fixing points available on support brackets must be utilised, ensuring all coach bolts or fixings are firmly secured and tightened post installation.
- Check joint parts on each installed unit every three months, making sure that the coach bolts or fixings have not come loose.
- Never exceed the 250kg weight limit for the shelving section. Never exceed the 250kg weight limit for the workbench. Loading product beyond the load rating could lead to product damage or physical injury.
- Recommended height of the workbench is between 900 -1000mm, with the shelving to be approx 750 -1000mm above the workbench.
- When storing items onto shelving above waist height, ensure care is taken. Take extreme precautions if handling items on a ladder.
- This product is intended for indoor use only. Use of this product outdoors could lead to product damage or physical injury.
- Do not install onto metal stud wall frames under any circumstances using the provided coach bolts and nylon anchors, they are for wooden stud & masonry installations only. If you are wanting to install Fleximounts products onto metal frame studs, we recommend using Hex Head 12g x 40mm Self Drilling Screws, available from any hardware shop.
- It is advised that you view our installation videos on our website prior to installation.
- Please call our office on 1300 794 434 if you have any questions.