



Let us
Perfect
 your water and
Enhance
 your lifestyle.

ERO 385

ECOWATER REVERSE OSMOSIS – DRINKING WATER SYSTEM

The quality of your home's drinking water may meet local standards, but it might not meet your own. Ordinary tap water can contain dissolved metals, including lead and iron. It might contain nitrates, chlorine and mineral salts. Your tap water could also contain other undesirable substances such as sulfates and arsenic. Fortunately, you can get cleaner, clearer drinking water with an EcoWater drinking water system.

Features:

- 50 gallons per day production rate, industry rated, high recovery 42% membrane. (actual production rate will vary depending on water usage and conditions).
- The filters are enclosed for cleanliness and ease of replacement.
- Changing filters does not require turning off the water, a simple 1/4 turn of the filter shuts off the water and the filter is released at the same time.
- Post-filter reduces **PFOA, PFOS** and **VOC's**.
- Additional filter selections are available including alkaline.

Options:

- Unique and elegant chrome or brushed nickel faucet styles.
- Optional electronic faucet indicates when filters and membrane need to be replaced.
- System is expandable if additional filters need to be added.
- 75 gallon per day membrane.
- Adaptor kits are available to easily add a permeate pump system, which provides improved flow rates at the faucet.

PURER WATER IS IDEAL FOR:

- Drinking
- Coffee and tea
- Cooking
- Ice cubes
- Baby formula
- Juice concentrates
- House plants
- Steam irons

Removes
 99.1%
 Lead

BPA-Free
 System



OPTIONAL
 Electronic Monitoring
 Faucet Base

Designed, Engineered &
 Assembled in the U.S.A.

ERO 385

ECOWATER REVERSE OSMOSIS – DRINKING WATER SYSTEM

Here's How an RO Works:

- 1 Household water is directed through a prefilter for filtration to remove sediment, chlorine taste and odor, and particulate matter.
- 2 The water is then forced, by pressure, through a semi-permeable membrane where a high percentage of the dissolved solids, etc. are rejected and flushed to the drain.
- 3 Filtered water is reserved in the storage tank until needed. An activated carbon absorption block filter that removes tastes and odors polishes the water immediately before going to the faucet.

DIMENSIONS

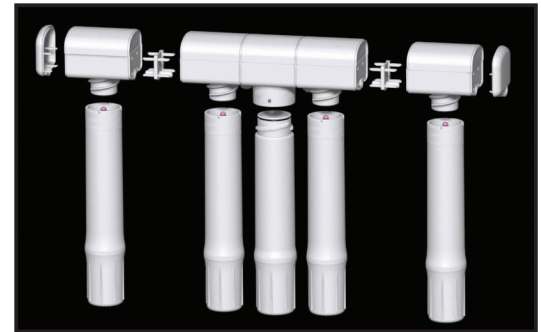
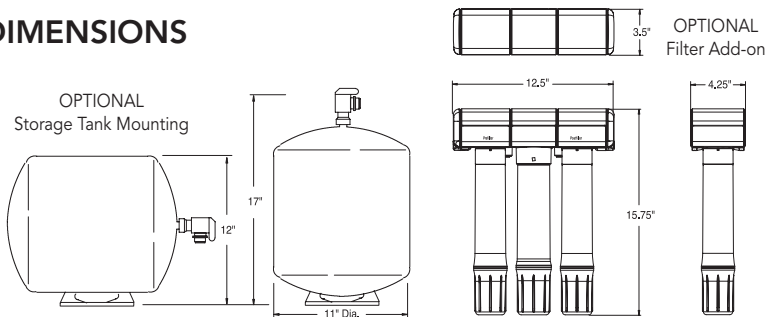

SPECIFICATIONS

ERO 385

Feed water pressure (min.-max.)	40-100 psi
Feed water temperature (min.-max.)	40-100°F/4-38°C
Maximum Total Dissolved Solids (TDS)	2,000 ppm
Membrane percent rejection of TDS	90%
System product water production rate (gal. per day)*	15.75
Feed water pH limits	4-11 pH
Maximum iron	0
Maximum hydrogen sulfide	0
Type of membrane	high recovery, thin film composite
Pre-filter (sediment/chlorine taste & odor)	block carbon
Post-filter (contaminant)	block carbon
Water Recovery	42%
Optional:	
Sediment filter	
High-flow membrane	
Permeate pump adaptor	
Storage tank size	4 gal.
Automatic shut off valve	yes
Shipping weight	16 lbs.

*Tested to NSF/ANSI Standard 58.

ERO 385: For municipal and well water supplies. Chlorine must not exceed 2.0 ppm.

WARRANTY

- Five years on the reverse osmosis drinking water system for defects in material and workmanship, and 10 years on the storage tank.
- Exclusions to five years; one year on reverse osmosis membrane, three years on faucet and seven years on electronics.
- The service life of the membrane and filter cartridges is dependent on the feedwater quality. Filters are not covered by the warranty.

ECOWATER
SYSTEMS®



Your Water. Perfected.

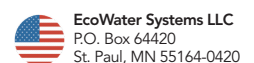

This drawing illustrates some of the customizable filter connection options the ERO 385 has to offer. Additional filter(s) may be added on to either side of standard unit.

- Optional sediment filter available
- Optional NSF Certified VOC* filter available

* VOC = Volatile Organic Compounds, 53 compounds in all, including Atrazine, Benzene, Carbon Tetrachloride, 2,4-D, Toluene, Trihalomethanes, and Xylenes

Typical impurities reduced by an EcoWater Reverse Osmosis Drinking Water System Model ERO 385 TFC System.

- Ammonium¹
- Arsenic²
- Atenolol³
- Barium
- Bicarbonate¹
- Bromide¹
- Bisphenol A³
- Cadmium
- Carbamazepine³
- Chloride¹
- Chromium (Hex)
- Chromium (Tri)
- Chlorine Taste & Odor
- Copper
- Cysts (Giardia/Cryptosporidia)
- DEET³
- Estrone³
- Fluoride
- Ibuprofen³
- Lead
- Linuron³
- Magnesium¹
- Meprobamate³
- Metolachlor
- Naproxen³
- Nitrate/Nitrite
- Nonyl phenol³
- Phenytoin³
- PFOA/PFOS
- Radium 226/228
- Selenium
- Sodium¹
- Sulfate¹
- Tannin¹
- TCEP³
- TCCP³
- TDS
- Trimethoprim³
- VOC
- Turbidity
- Zinc¹

Tested and Certified to NSF/ANSI Standard 58 by NSF International. Rated at 50 psi, 77 F, 750 ppm/TDS, product to storage tank. Product water produced, amount of waste water and percent rejection will vary with changes in pressure, temperature and total dissolved solids.

¹Tested by Spectrum Labs, Inc. a state certified testing laboratory.

²The system reduces pentavalent Arsenic (As V). The system has been validated on a chlorinated water supply. For more information, see the Arsenic Facts located in the back of the owner's manual.

³Tested by IAPMO.