

05-42551

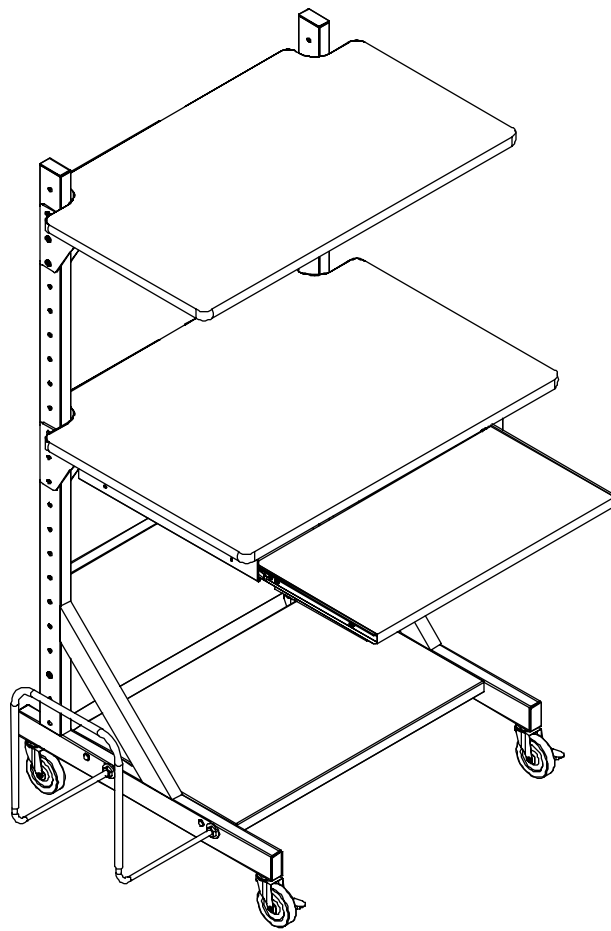









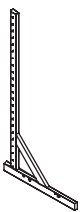
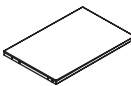

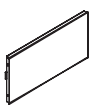

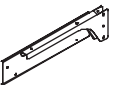

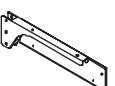



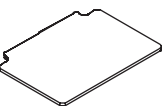

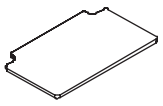
Adjustable Tri-Level Computer Workstation

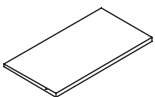

**Assembly Instructions**

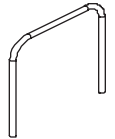
# 05-42551

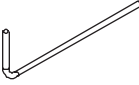
# Computer Workstation

Part	Drawing	Description	Qty	Part	Drawing	Description	Qty
P1		Leg	2 EA	<b>Hardware List</b>			
P2		Bottom Shelf	1 EA	A		Flat Head Screw	28 EA
P3		Stability Panel	1 EA	A2		Long Wood Screw	4 EA
P4		Right Top Support	1 EA	A3		Wood Screw	3 EA
P5		Left Top Support	1 EA	B		Interior Threaded Post	20 EA
P6		Shelf Support	2 EA	D		3" Locking Caster (for Front)	2 EA
P7		Top Panel	1 EA	E		3" Caster (for Back)	2 EA
P8		Shelf Panel	1 EA	F		Allen Wrench	1 EA
P9		Cable Tray	1 EA	G		Caster Wrench	1 EA
P10		Keyboard Shelf	1 EA	M		Slide	2 EA
P11		CPU Sleeve	1 EA	N		Flat Washer	4 EA
P12		CPU Rod	2 EA	P		Black Plastic Spacer	2 EA
				Q		Hex Nut	4 EA
				<p><i>We recommend that you assemble this unit on a table.</i></p> <p>Tools required: Philips Head Screw Driver, Adjustable Crescent Wrench</p>			

# 05-42551 Assembly Diagram

To Assemble:

Illustration # 1

1. Identify and Separate all the Parts and Hardware.
2. Attach Bottom Shelf (P2) and Stability Panel (P3) to 2 Legs (P1) using 8 Flat Head Screws (A) and 8 Interior Threaded Posts (B) as shown in Illustration # 1.

*(Do not tighten screws all the way)*

3. Attach Casters to 2 Legs (P1). 2 Locking casters (D) in the front and 2 Casters (E) in the back. Tighten Casters using Caster Wrench (G).

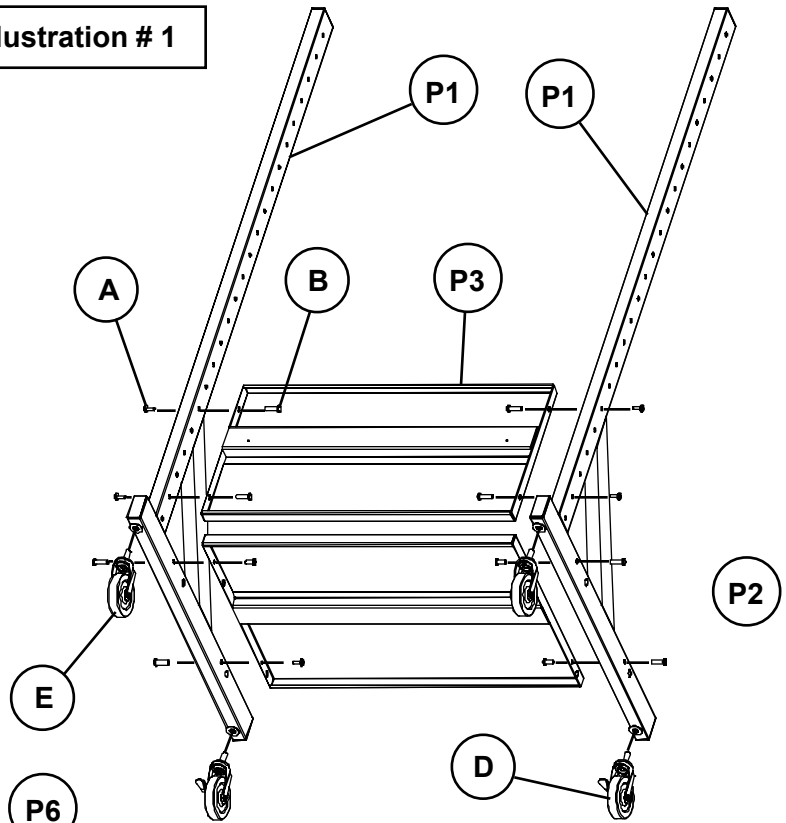
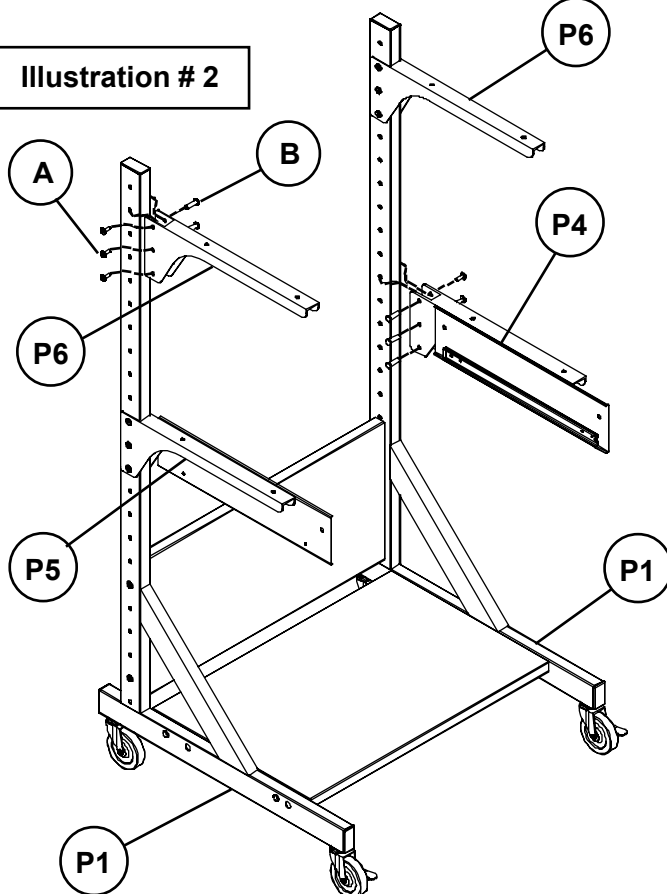
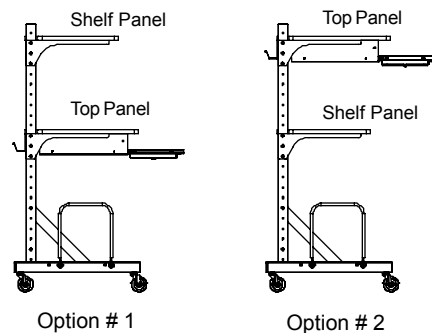

Illustration # 2



4. Attach 1 Right Top Support (P4) and Left Top Support (P5) to 2 Legs (P1) at desired location (see Options below) using 6 Flat Head screws (A) and 6 Interior Threaded Posts (B) as shown in illustration # 2.

5. Attach 2 Shelf Support (P6) to 2 Legs (P1) at desired location using 6 Flat Head screws (A) and 6 Interior Threaded Posts (B) as shown in illustration.



**Illustration # 3**

6. Attach Top Panel (P7) to the Top Supports (P4 & P5), and Shelf Panel (P8) to the Shelf Supports (P6) using 8 Flat Head screws (A) as shown in Illustration # 3.
7. Attach cable Tray (P9) to the Top Panel (P7) using 3 Wood Screws (A3).
8. Attach 2 slides (H) to Keyboard Shelf (P10) using 4 Long Wood Screws (A2) as shown in illustration # 4.

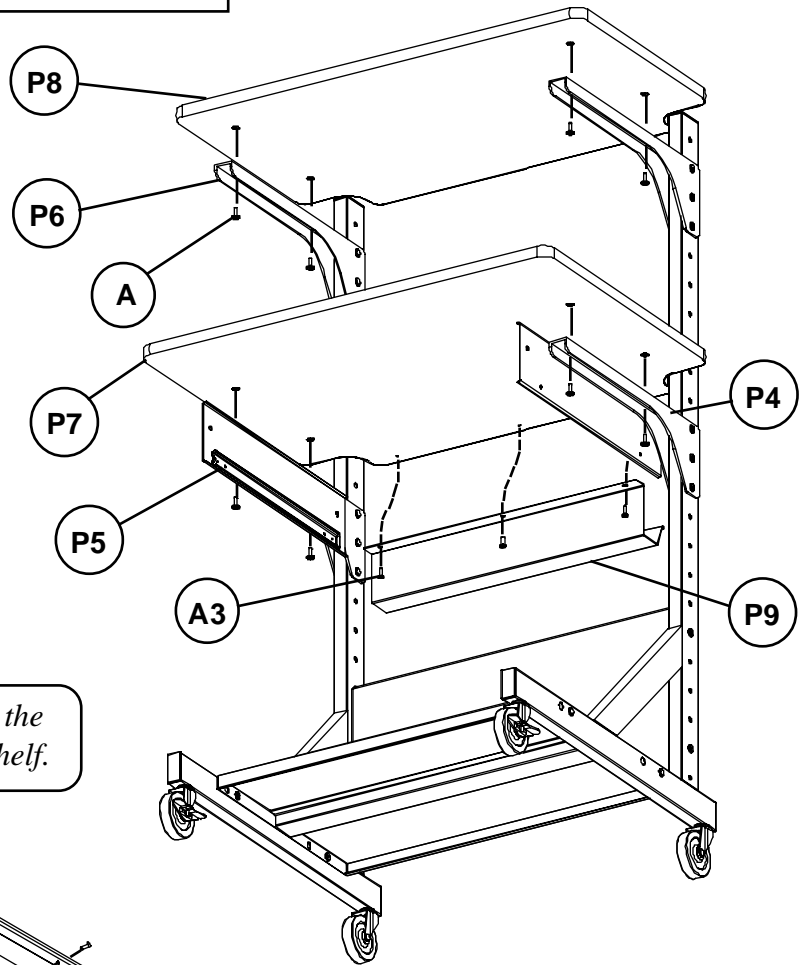

*Spring Clip goes to the back of Keyboard Shelf.*

**Illustration # 4  
Keyboard Shelf**

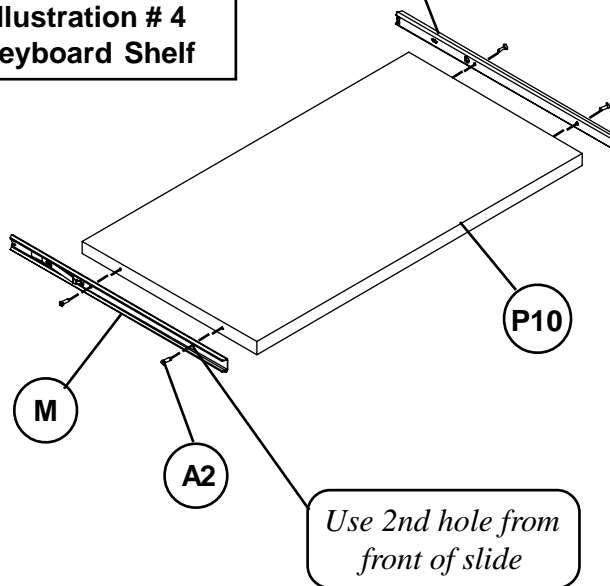

**Illustration # 5**

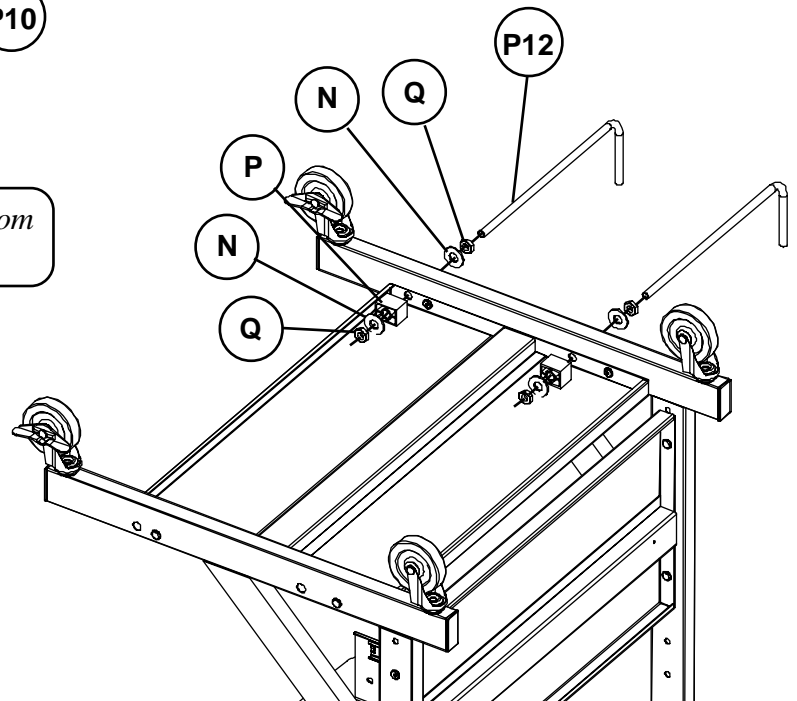

9. Attach 2 CPU Rods (P11) to the Right Leg or Left Leg as shown in illustration #2.

Secure each Rod with 2 Hex Nuts (Q), 2 Flat Washers (N), and 1 Black Plastic Spacer (P).

Illustration # 6

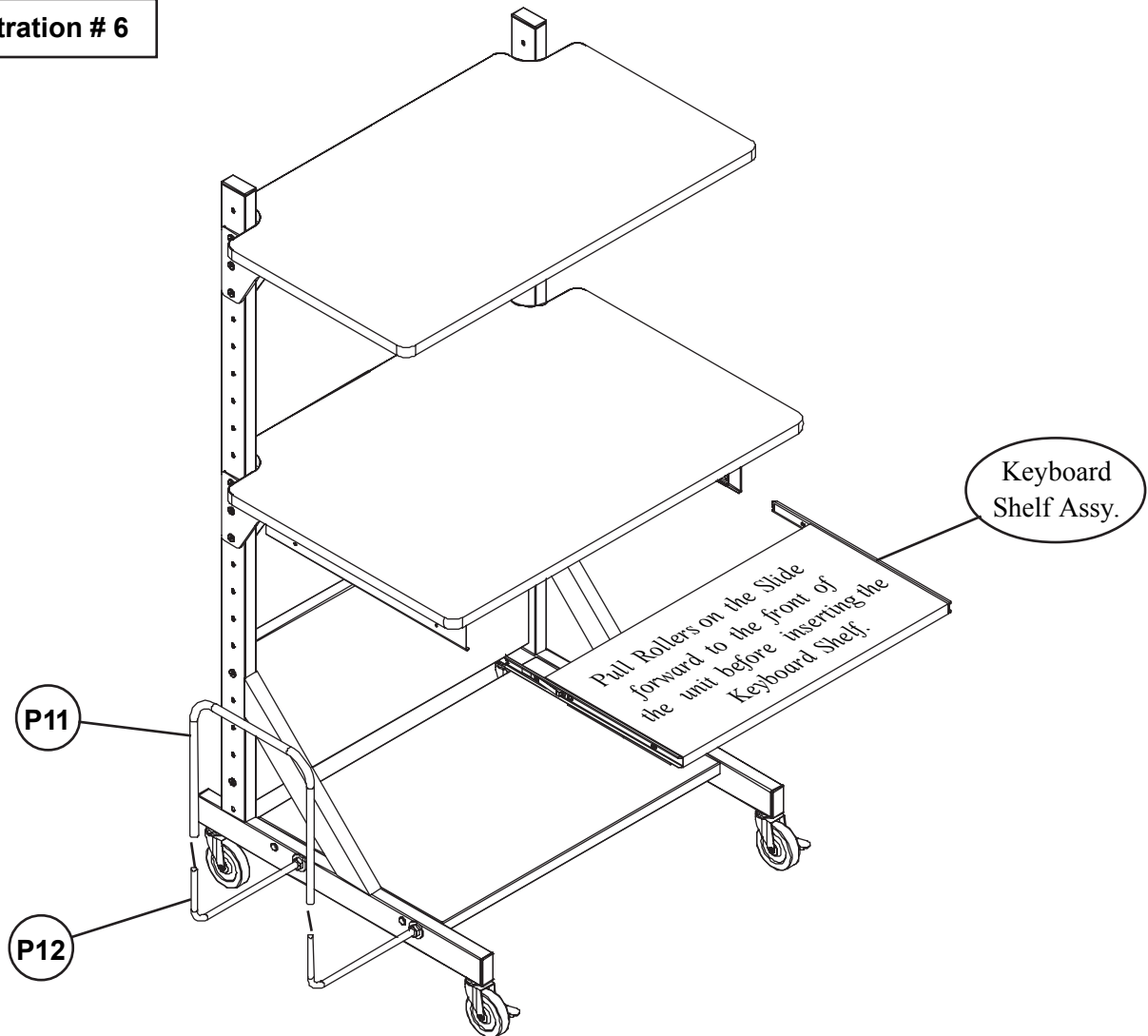

10. Slide CPU Sleeve P11 over ends of CPU Rods (P12) as shown in illustration # 6.
11. Insert Keyboard Shelf Assembly and Pullout Shelf Assembly into the Right and Left Slide Panels as shown in illustration # 6.

*(Note: Pull Rollers on the Slide forward to the front of the unit before inserting the Keyboard and Pullout Shelves).*

12. Tighten all screws securely.

Alekto3\_asm - 03/13/00

Do not use unless all screws are tight. At least every six months, check all screws to be sure they are tight. If parts are missing, broken, damaged, or worn, stop use of the product until repairs are made by your dealer using factory authorized parts.

**Should you require assistance during assembly, please call our Customer Service Department**  
**Monday - Friday 7:30 a.m. - 4:30 p.m. Pacific Standard Time**  
**Toll-Free Customer Service**  
**1-800-888-6024**