



EUROPEAN PLASTICS

PLASTICS FOR THE BUILDING INDUSTRY

CDV

Continuous Dry-Verge



Tile Dry Verge



Slate Dry Verge



Profile Range

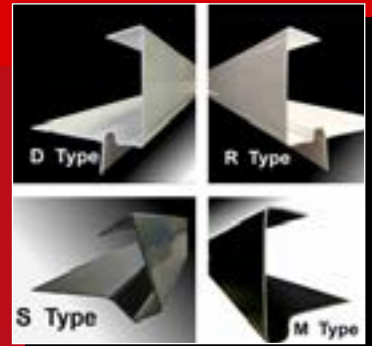

Continuous Dry-Verge, Dry Fix & Roofline Building Plastics

Continuous Dry Verge Introduction

The Continuous Dry Verge System has been specially designed to overcome the problem of water penetration at gable ends. It provides complete and continuous watertight cover for the joint between roof tiles and brickwork or bargeboard, giving greater security to the verge. Continuous Dry Verge is a fast and effective dry fix solution, without the inconvenience of using mortar and clips, providing a maintenance free, clean, attractive finish to gable ends.

Compatible with Flat, High and Low Profiled tiles, including Plain & Rosemary Tiles, manufactured by all major tile suppliers.

The 'S' Profile is compatible with interlocking slates, along with both natural and fibre cement slates.

Composition

The material used is of high quality, external grade, rigid pvc, which is extremely resistant to light degradation and atmospheric pollution.

Information

Manufactured in 5mtr & 6mtr lengths, in a choice of colours. A full range of connectors and ridge end caps to complement the range.

Fitting

The Continuous Verge is quickly and easily fitted. No adhesive or special tools are required. Please refer to our detailed fitting instructions on pages 6 & 7, for both Slate & Tile profiles.

Storage

We recommend the Continuous Dry Verge be stored horizontally, in a cool place, under cover and away from direct sunlight

Advantages

Gives complete continuous cover against water penetration for joint between tiles and brickwork or bargeboard at gable ends. Gives greater security and added strength against wind damage by securing end tiles firmly.

- No undercloak required.
- No mortar joint required.
- No special tools or adhesives.
- Saves time and labour.
- Can be fitted in all weathers.
- Available in 5 metre and 6 metre lengths.
- Connector units available for longer runs.
- Ridge end units complete the apex.
- Gives a neater attractive line and finish to gables ends. No maintenance required
- Gives that added finish when used with uPVC bargeboards fascia and soffits.

Colours

Extruded in **Black, White, Brown, Caramel and Anthracite Grey**.

4 types suitable for use with Slate, and most Concrete Roof Tiles.

Continuous Dry Verge Profile Dimensions

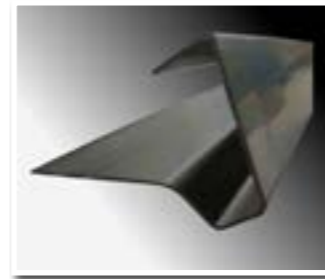

S Type

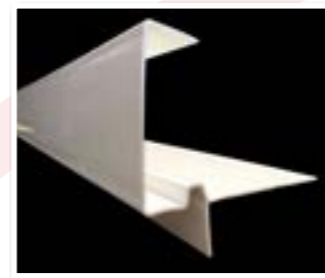

R Type

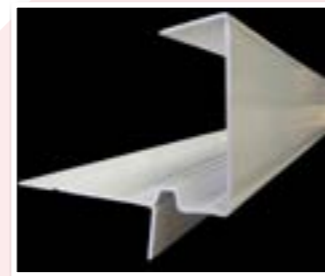

D Type



M Type

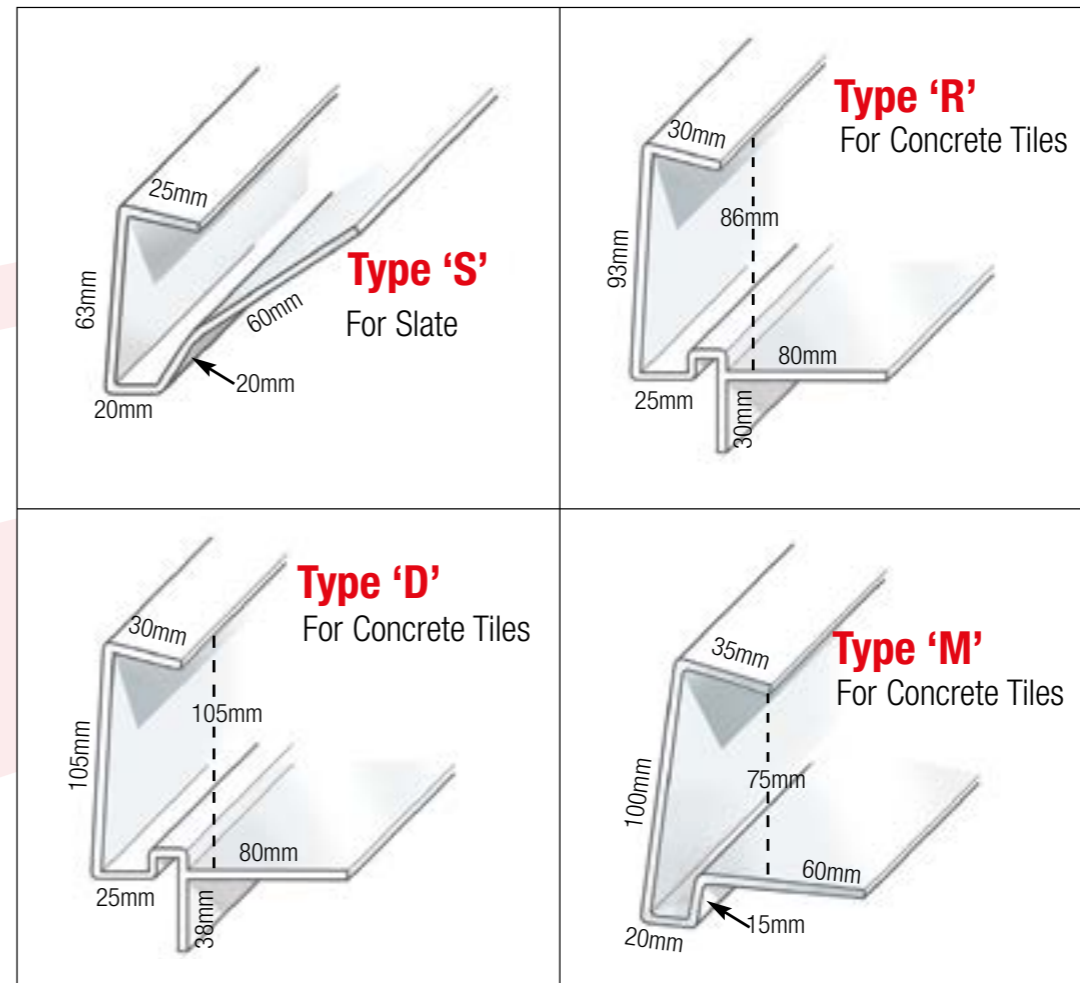

Connectors



S Type



R Type



D Type



M Type

Ridge End Caps



Caramel



Brown



Anthracite Grey

Length	Colour
5m & 6m	Black & White
5m	Brown, Caramel Anthracite Grey
Pack Size	
3 Per Pack	Split packs available



Continuous Dry Verge Tile Profile Fitting

The Continuous Dry Verge should be cut to the required length, allowing for a plumb cut at the ridge, and approximately 150mm longer than the rafter. The horizontal flange is cut away, to allow fitting over the felt support tray at the eaves.

The battens are placed against the lip of the water channel of the dry verge, which are then nailed into position directly through the horizontal fin of the Verge. The nails are fixed through both batten and verge, into the timber rafter. A close-up of the roof battens in place show their position against the lip of the drainage channel.

Once all the battens are fixed in place, and the Dry Verge secure, the roof is ready for tiling. The roof tiles are fitted in the usual manner, ensuring that the verge tiles are fully inserted into the verge, where the top flange will hold them firmly in place.

At the eaves, the verge should be cut square, flush to the lower tile, and notched into the gutter. **Eaves stop ends** are available for closing the eaves on the 'R' and 'D' profiles. The water channel allows any rainwater to run directly into the rainwater gutter.

The fitted Continuous Dry Verge achieves a professional finish. This will be similar for any roof tile or slate being used. The completed roof gives complete continuous cover against water penetration, and added strength from wind damage by securing end tiles firmly.



Continuous Dry Verge Slate Profile Fitting

The roof battens are fixed in place to the required slate gauge, however, the batten ends are not fixed in place as yet, to allow the 60mm flange of the slate verge to be fitted under the batten, which is the easiest way to fit in place.

The roof battens ends are then securely fixed in place, by nailing through both batten and verge, into the timber rafter.

The slate verge profile is then at an angle, which is manufactured in that way, so the top flange clamps down on any thickness of slate, from a 5/6mm general slate to 12/13mm natural slate.

To open the external face of the slate verge, a temporary batten is placed between the batten courses, which is pushed against the inner face of the slate verge, and nailed in place. This opens the profile of the verge to a vertical position.

The slates are fixed in place in the usual manner, with the outer edge of the slate fixed against the internal edge of the verge. This will hold the verge in the vertical position, and continue this procedure in the normal manner up the verge of the roof.

The Continuous Slate Dry Verge achieves a professional finish. This will be similar for any slate being used. The completed roof gives complete continuous cover against water penetration, and added strength from wind damage by securing end slates firmly.



Profile Compatibility Table

Tile & Slate

For use with a 25mm batten	Manufacturer Name	Tile Name
R TYPE	MARLEY	Ludlow Plus; Eco, Std Ludlow Major; Modern; Duo Modern; Plain Tile; Clay Plain Tile Range; Double Roman; Acme Plain Tiles, Hawkins Plain Tiles; Ashmore; Edgemere Range; (See below on Bold products)
	REDLAND	49 Tile; Renown; Landmark Double Roman; 50 Double Roman; Stonewold MK2; Mini Stonewold; Mockbond Mini Stonewold; Rosemary Tiles; Plain Tile; Heathland Plain; Duo Plain; Richmond 10; Mockbond Richmond 10; Landmark 10; Saxon 10; Westminster Slate; (See below on Bold products)
	SANDTOFT	Standard Pattern; Calderdale; Dual Calderdale; Lindum; Plain Tile; 20 20; Actua; Vauban; Rivius; Cassius; TLE (Thin Leading Edge); (See below on Bold products)
	RUSSELL	Grampian; Highland; Plain Tile; Galloway; Lothian; Moray; Polden; Bute; (See below on Bold products)
	FORTICRETE	Centurion; V2; Senator; Hardrow; Plain Tile; Gemini; Mini Slate; (See below on Bold products)
	QUINN	Western Slate; Rathmore; Devenish; (See below on Bold products)
D Type	MARLEY	Double Roman; Mendip; Wessex; Anglia; Clay Pantile; Clay Double Roman
	REDLAND	Regent; Grovebury; Landmark Double Pantile; Clay Pantile Range
	SANDTOFT	Double Pantile; Double Roman; Shire Pantile; Modula Range; Olympus; Arcadia
	RUSSELL	Pennine; Double Roman
	QUINN	Locherne
S Type	MARLEY	Rivendale; Birkdale; Garsdale; Thrutone
	REDLAND	Cambrian
	SANDTOFT	Britlock; Britslate
M type may be used on Bold Items; (based on maximum Batten Gauge & Tile Lap)		

Continuous Dry Verge

In Situ





EUROPEAN PLASTICS

PLASTICS FOR THE BUILDING INDUSTRY

GRP

GRP Roofing Range



Slate Valley



Dry Bonding Gutter



Tile Valley



Eaves Closure

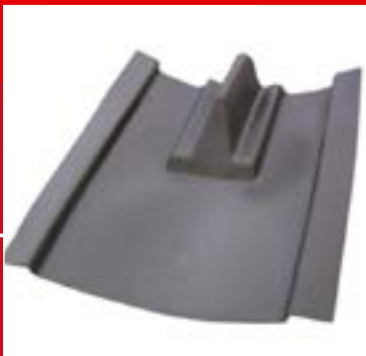

Dry Valley Tile



Top Closure

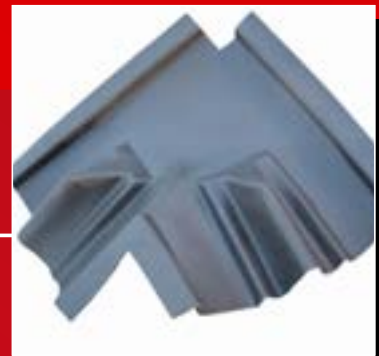

GRP V-Flow Roofing
Dry Fix Valley, Bonding Gutter,
Abutment Soakers

01639 890578
www.europeanplastics.co.uk
info@europeanplastics.co.uk