

A I R M A N A G E M E N T S Y S T E M



INSTALLATION MANUAL



Thank you for choosing the HKI Movee Air Suspension Management.

The Movee manages and controls your air suspension via Bluetooth, works with any air suspension system that uses 8 electric valves, manually and or automatically.

Movee also has a system of height presets that can be programmed upon the reading of height sensors or, in a simpler way, operating based valve timing.

To achieve the maximum level of quality and innovation both the hardware and the software were developed from scratch, and designed to work in perfect harmony with each other.

In order to ensure a great experience with the product, the information in this manual must be followed.



Terms and Conditions

Broken or missing parts? Please contact us at www.hkairsuspension.com

We guarantee our products against manufacturing defects.

HKI AIR SUSPENSION is limited to repair services or replacement of parts and /or kit components, in the terms listed below and upon examination by professionals of the company itself. Finding the existence of defect of material or manufacture, HKI may choose replacing the damaged product with a new one. Depending on the severity and extent of the problem, **HKI AIR SUSPENSION** may choose to replace the damaged product with a new one.

HOW TO CLAIM WARRANTY?

- Presentation of the purchase receipt.
- Conducting a technical analysis of the product to verify the defect claimed. This analysis is carried out presenting the situation directly to the warranty department by filling the form at www.hkairsuspension.com
- This analysis consists on the payment of a postage fee (if there is a need to send the product back to the factory) being returned to the customer if the defect is confirmed under the terms of this Warranty.

Situations not covered by this Warranty.

The warranty does not apply to products that have been improperly installed or set up, or have not been maintained in accordance with the instructions for installation or exposure to adverse and unforeseen conditions.

- Damage caused during the transport of the product, when the service is/was the buyer's choice.
- Misuse, improper efforts, or any type of use other than that proposed by the product manual.
- Problems caused by assembly in disagreement with the instruction manual or related to adaptations and /or changes made to the product.
- Mistreatment, carelessness and / or maintenance in disagreement with the instructions passed by **HKI AIR SUSPENSION**.
- Damages caused by third party services hired by the consumer.
- Damage caused by accidents, abuse, misuse, faulty installation and all external causes.

Legal Notice

- **HKI Movee Air Suspension Management** is a product intended and designed for off-road use. If the **CUSTOMER** chooses to use the product on the streets and roads, he is aware that he is doing so at his own risk.
- **HKI AIR SUSPENSION** products may void or limit any warranty of the vehicle manufacturer; therefore, you will have no liability for any effect that the installation of your products may have on such warranties or service contracts.
- **HKI AIR SUSPENSION** products may drastically alter the handling characteristics of the **CUSTOMER's** vehicle and may cause the vehicle to operate in a manner not intended by the vehicle manufacturer. The installation and operation of the system is at the **CUSTOMER's** own risk.
- The **CUSTOMER** is responsible for periodically inspecting each, and every **HKI AIR SUSPENSION** product or component installed in the vehicle, to ensure that they remain safe and functional. The company will have no responsibility for any problem caused by the lack of inspection by the **CUSTOMER**.
- **HKI AIR SUSPENSION** shall have no liability for damage to property or people caused by its products, components, accessories, installation instructions or otherwise. The **CUSTOMER** alone assumes all these risks and responsibilities.
- **HKI AIR SUSPENSION** is not responsible for systems, products or components supplied by other manufacturers to use in conjunction with the **HKI Movee Air Suspension Management system**. For components other than **HKI AIR SUSPENSION** follow the manufacturer's instructions for installation and operation.
- The liability of **HKI AIR SUSPENSION**, if any, will be limited to the cost of replacing the purchased product or components.

Main functions: HKI Movee Air Suspension Management

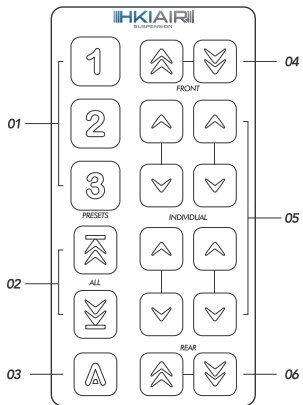

- 01 - Programmable heights
- 02 - Maximum and Minimum Height
- 03 - On/Off Auto Adjustment Function
- 04 - Front Manual Control
- 05 - Individual Manual Controls
- 06 - Rear Manual Control

The Movee controls manually and automatically any air suspension system with 08 electric solenoids, and with the use of position sensors in the suspension monitoring. This system automatically corrects the vehicle's height when the load level changes, when the AUTO ADJUSTMENT function (03) is activated, reducing the need of changing it manually.

On the left side of remote control are the setting height buttons (01), the maximum and minimum height buttons (02) and the button to activate and deactivate the Auto Adjust function (03) if you have the position sensors installed. At the right top, there are the manual drive of the front (04) and at the bottom of the controller the manual drive of the rear of the vehicle (06).

In the the middle section, are the individual controls, responsible for each bag on each wheel of the vehicle. (05).

By default, when calibrating the position sensor, the three heights are pre-programmed to:

- Level 1 - 10% of the total height of the vehicle as standard.
- Level 2 - 50% of the total height of the vehicle as standard.
- Level 3 - 90% of the total height of the vehicle as standard.

If the system does not have the height sensors installed/connected, the three height levels must be configured manually via the application and will work by lifting the entire



We do NOT indicate pressing the function button all low with the vehicle in motion, since this function can release all the air from the bags.

Electrical and Pneumatic Connection for Valve Manifold

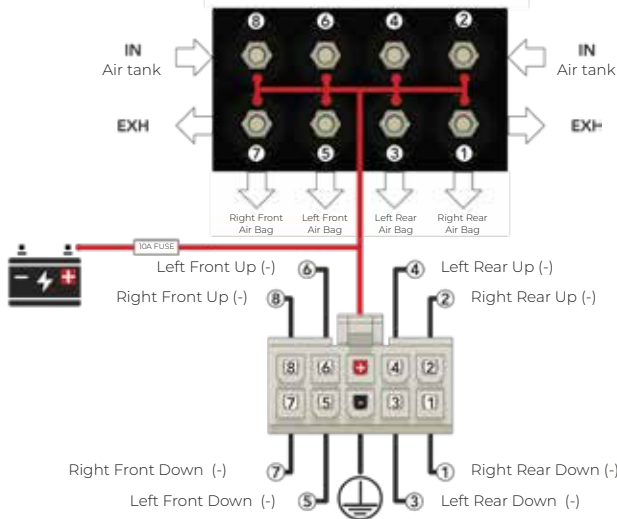

IN SUMMARY:

The electric harness of the Movee system has 10 pins: 1 constant 12v POSITIVE pin (using 10A fuse), 1 NEGATIVE pin and 8 pins to connect to the valves (NEGATIVES – negative switching).

That said, consider:

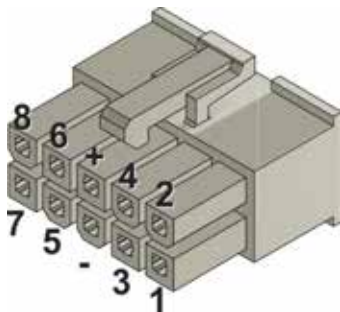

- 1 - Right Rear Valve Down
- 2 - Right Rear Valve Up
- 3 - Left Rear Valve Down
- 4 - Left Rear Valve Up
- 5 - Left Front Valve Down
- 6 - Left Front Valve Up
- 7 - Right Front Valve Down
- 8 - Right Front Valve Up
- + - Constant Positive (12v)
- Negative

ATTENTION:

The Movee Air Suspension Management uses 12v as the common connection between the ECU electronics and the valves, so ONE wire from each valve must connect to the positive wire of the harness. This 12v source should be constant and not post-key.

The triggering of the valves is done by negative pulses, so no power source should be connected to the wiring harness except for the single positive pin (+).

Installing The Movee Air Suspension Management

Once installing the air suspension system is done you can proceed to install the Movee in the following order:

- 1 - Disconnect the positive from the battery;
- 2 - Make the passage of the positive (with fuse of 10A) and negative of the central by the vehicle.
- 3 - Set the electrical connection of the valves according to the electrical scheme provided;
- 4 - Connect the positive of the battery and make sure that the internal lights of the Movee ECU have lit.
- 5 - Open the Movee app and connect your device's bluetooth to the ECU.

Extra steps for the system with height sensors

- 6 - Pass the wiring harness from the height sensors and plug into the module;
- 7 - Install the position sensors in the vehicle*

* The height sensors must be previously installed to choose between the height sensor or the time based mode within the APP. This way, you can follow the reading displayed by them and calibrate the vehicle, appropriately.



To ensure safety, there can NOT be any type of air leakage in the pneumatic system.

Bluetooth connection

The connection between ECU and mobile device it's only necessary the first time. To enable the bluetooth go to settings and select the first option, "bluetooth connection".

In this option it will be possible to make the Bluetooth pairing and nce this first connection is stablished, we recommend setting a new password according to your preferences. If requested, the standard password : 8888 (four times number eight).

Installation of the Electrical Harness of the Sensors

The Movee Air Suspension Management is prepared to identify the reading position of the height sensors by performing the complete calibration system. But, we advise considering the following information, so the order of the harness installation of the sensors is:

- Tag 1 - Right Front Sensor
- Tag 2 - Left Front Sensor
- Tag 3 - Right rear sensor
- Tag 4 - Left rear sensor



The harness of the sensors is waterproof, so, if necessary, it can be installed inside or outside the vehicle (following the rail, for example). Do not forget, the wiring must stay away from friction, heat or twist for full operation.

Installation of Position Sensors

- The Movee Air Suspension Management uses 4 position sensors (one for each wheel/corner) to monitor the height of the vehicle, they are waterproof and there is no difference between sensors on the right to sensors on the left.
- **They must be installed on the body/chassis (part of the vehicle that does not vary in position with the suspension working) with the harness plug facing the rear of the vehicle and the sensor arm facing the front of the vehicle. ***
- A rod connects the sensor arm to the suspension attachment point (part of the vehicle that varies in position with the suspension working). In most front suspensions this part is the tray (top or bottom) or control arms.
- When installing sensors, the goal is to achieve the highest of their rotation, without exceeding their limits (100 ~ 120°).
- It may be necessary to shorten the sensor rods and make new attachments to the vehicle. This way, ensure that the arms are rotating enough during suspension operation to precisely determine the height of the vehicle.
- The sensor should be fixed to the body/chassis using the self-drilling screws thus eliminating the need to use washers.
- Once installed, make sure the sensor does not touch any suspension component while the suspension goes up and down. It is very important to always check the steering movement in front of the vehicle.

Visualizing and understanding the whole suspension movement is the key when installing the sensors. The term 'vertical stroke', is the travel value of the suspension when the whole vehicle is down the height is measured by a point of the suspension that at one end is fixed, and on the other end moves up and down. Keep in mind that the fixed end only rotates, but there is no vertical movement. If you install the position sensors too close to the fixed end, while suspension works, the vertical stroke will be small to almost none. If you install the sensors on the other end, where the vertical stroke is extreme, you will compromise the reading and operation of the system and may cause damage to the sensor.

See the illustration below:

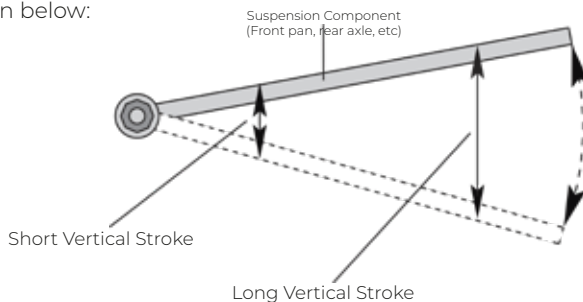

*We indicate this installation pattern of the sensors so it is possible to perform the **SIMPLE CALIBRATION** of the system through the app.

But if there is a need, for whatever reason, to mount in the opposite direction (reading arm facing the rear and harness plug facing the front of the vehicle), the system will initially make an opposite reading, showing the inverted variation in the application. If this happens, performing a **COMPLETE CALIBRATION** so the system recognizes this new installation standard of the sensor(s)

Installation of Position Sensors



To install the sensors correctly it is necessary to simulate the suspension and steering movement. It is very important for your safety, that this process is done on an elevator, ramps, trestles or jack, DO NOT get under the vehicle during this process!

Set an ideal position on the vehicle to fix the position sensors, respecting every information described in the manual to have a measurement consistency within the next steps. After this, it is necessary to simulate the total course of the suspension. This step will determine if the position chosen for the sensors will work, and if the reading will be within the 100° limit the sensor has.

With the bag completely out of air, simulate the suspension movements with the jack at the lowest limit (car completely down). Check that the sensor mounted with the rod is within the reading margin according to the **template** (provided at the end of this manual). Repeat this same process, but now with the simulation of the suspension at the highest limit (simulating full bags/vehicle off the ground in an elevator preferably).



During the suspension movement, there must not be any kind of twist or lateral angle movement in the assembly of the rod that connects the sensor reading arm to the moving part of the suspension. The rod must be 100% parallel to the sensor reading arm throughout the suspension movement.

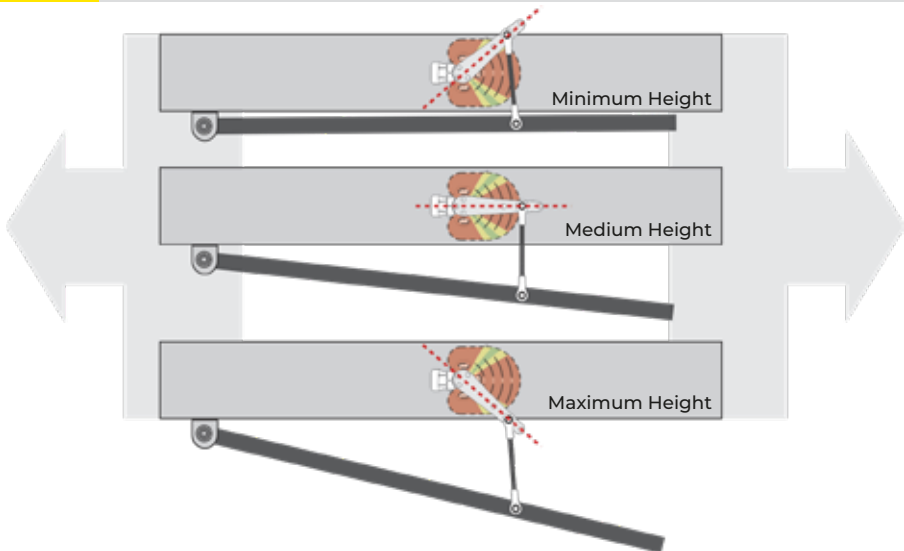

During the simulation of the suspension total movement, it is important to verify that the wheel/tire assembly will not under any circumstances touch any part of the sensor and its components make sure to always check the steering system (steering angles) in the front system.

Turning on the complete system for the first time

Once installing the position sensors (testing the suspension and steering stroke) and the manifold harness (or the valve manifold with the wiring harness), passing through the vehicle the appropriately, it is time to **calibrate the sensors**.

This process must be done with the vehicle in a 100% leveled location, free of objects or any variable that may interfere with the movement of the vehicle's suspension.

Movee Air Suspension Management has two kinds of calibration.

- **Simple Calibration:** The vehicle will rise entirely for 10s and lower entirely for 10s - This calibration should be chosen if when manually controlling the vehicle's suspension via the app the sensor reading is corresponding exactly the same as the vehicle within the four corners. That means, if when triggering to lower the right front suspension - the main reader of the upper right sensor goes down and this happens with every manual drive (if the sensor harness order is in accordance as the informed, and the 4 height sensors are with the reading arm to the front of the car and the electric harness to the rear choose this option).

- **Full Calibration:** The vehicle will perform a series of torsion tests* to identify and correct via software any inverted or out-of-position reading of the sensors.

- This calibration should be chosen if when manually controlling the vehicle's suspension through main reader, one or more sensors are NOT responding correctly in the four corners. That is, if when triggering to lower one of the corners - the main sensor reader displays a reading in a different place or different direction.

***Please note that these tests will require more air volume in the pneumatic system to fill and empty the vehicle bags.**

DO IT WITH THE AIR TANK FULL.

CAUTION TIPS:

- Under no circumstances press the All-Low Function button (2) while the vehicle is running, this way the system will completely release the air from the bags.

- We suggest disabling the Auto Adjust function for extreme driving or on roads.

- Make sure the air tank is full before proceeding to the next tip.

- The vehicle must climb rise entirely at least once without the compressor(s) being activated if this does not occur the pneumatic system must be modified, increasing the pressure and size of the air tank, or adding another compressor.

Movee HKI App

Navigating the app, it's possible to identify several options in the settings tab. We will detail all the functions of the system next.

Interface Configuration - Some features of the application can be adjusted in this tab.

App interface color selection - Choose the color of your preference to be presented in the app.

You can leave your screen lights ON while using the app.

Hide the preset heights bar.

You can choose the language of your preference.



Bluetooth connection - Here it is possible to make the connection via Bluetooth between the device and the ECU Movee. This manual connection is required only once, after pairing and setting the access password the connection becomes automatic.

You can also disconnect manually by pressing the **Remove Device** button and change the connection password by pressing the **Change Password** button.

Movee HKI App



Timer Configuration - If the system does not have the presence of height sensors, it is still possible to configure three heights for the vehicle in a timed way.

It is necessary to select which height will be made the configuration, after that configure what the value in seconds for the total ascent of the vehicle.

To finish, simply select the descent time in percentage of each corner of the vehicle (this value in percentage is based ALWAYS on the ascent time previously selected)

You can also test this setting in real time by pressing the **Test Fit button**.

Safety Configuration - Safety system specific to the Australian market, which disables manual interactions with the moving vehicle*.

Valet Mode - By activating this mode, the system stops responding to all commands (manual and/or automatic) coming from the wireless control.

General Reset - Use this option to go back all factory defaults of the system.

*Based on a negative pulse coming from the handbrake. This system, after being properly installed, can be enabled or disabled by the application.



Movee HKI App

Height Limitation - Safety system based on the use of position sensors.

When active it is possible to adjust the maximum height and minimum height that the vehicle can reach walking or parked, these values are presented in percentage, always consider 100% as the highest height of the vehicle read by the sensors and 0% as the lowest height of the vehicle turned on by the sensors during calibration.

This system is a master rule when active - so the vehicle will never exceed these pre-established limits even by pressing the function all low or one of the programmable heights.



Compressor Configuration - It is also possible to control the compressors operating by adjusting with which air cylinder pressure the compressor should turn on and with which pressures should turn off.

It is necessary that the system has the digital pressure sensor installed and the electrical wiring of this system is in accordance with the scheme presented at the end of this document.



Movee HKI App

Controls Configuration - In this option you can configure and adjust the operating mode and characteristics of the wireless control and the wired control of the system.

Pairing - To pair the wireless controller to the system, use this option. Once this is done, the lighting options of the control will be available, these changes are in real time.

Functions of the Wired Control - It is also possible to change the functions of the 4 buttons of the control wired by the application by choosing between Manual Drive (manual drive up/down front and rear) or Preset Height (activation of position 1, 2 and 3 + function all low).



Valve Control - It is possible to activate the Pulse function in the manual activation of the air suspension. When the field is at 100% the Pulse function of the valves will be disabled, when choosing any value less than 100% the Pulse function of the valves will be active for the manual actuations of the valves.

There is also a valve protection system, adjust this time according to your need.

Valve cleaning - It can be done periodically or when there is any indication of dirt in the valve system. (The vehicle must be parked to use this function, the vehicle may lower unexpectedly during this cleaning)

Installation Pressure Sensor with 1 Electric Compressor

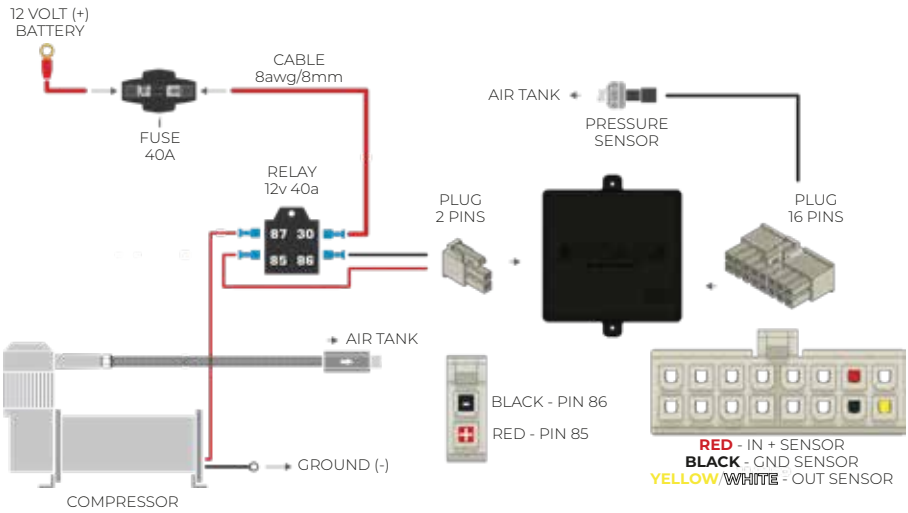

Installation Pressure Sensor with 2 Electric Compressors

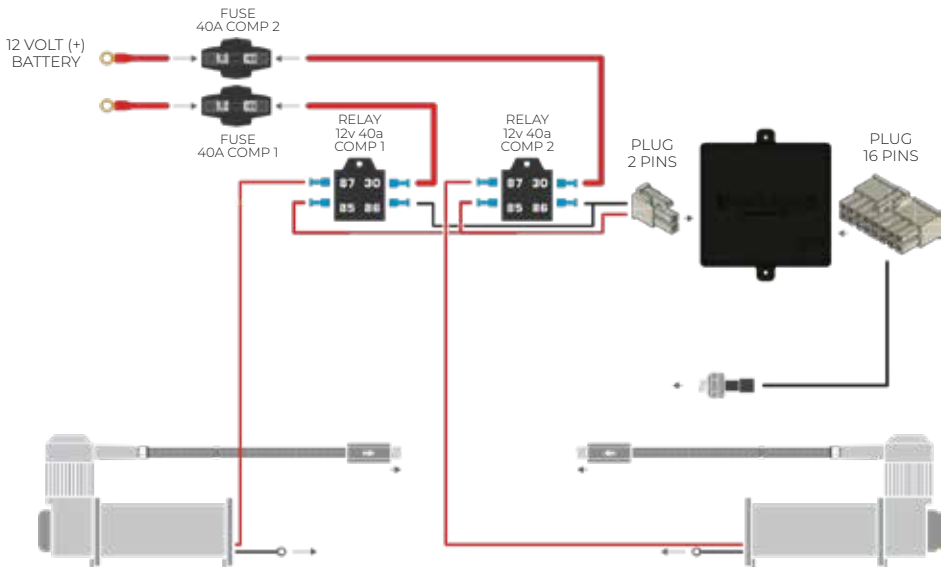

Installation of Safe Mode AUSTRALIA

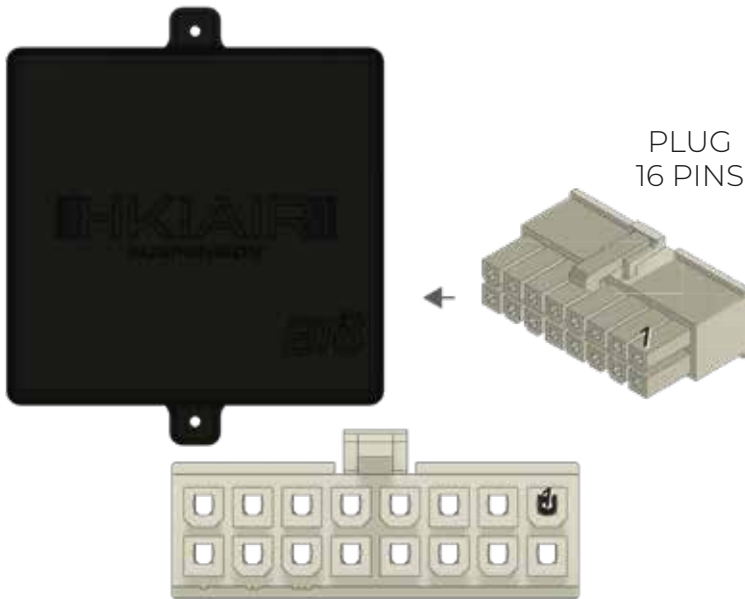

The parking brake safety system uses only a single pin on the 16-pin connector, as indicated in the above image. By connecting that pin to your parking brake warning light (ground), it will let the system know when the parking brake is engaged.

After installing that pin, open the Movee app and then go to Settings > Security in order to enable or disable that function.

When enabled, if the parking brake is disengaged, the system will not accept any commands.

Cut this template and use it as a reference for measuring the total reading range of the sensors during the component fixation tests in the suspension. Remember to base your measurements on the center of the sensor arm, as indicated by the red line shown on the side.

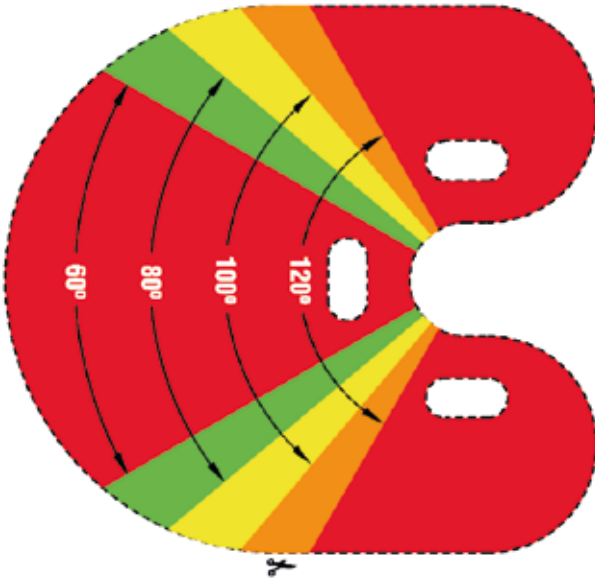
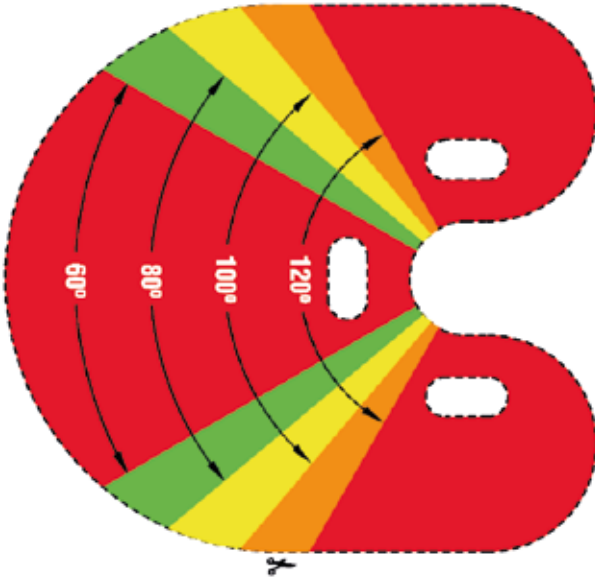
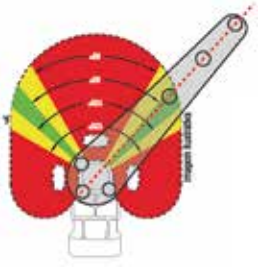

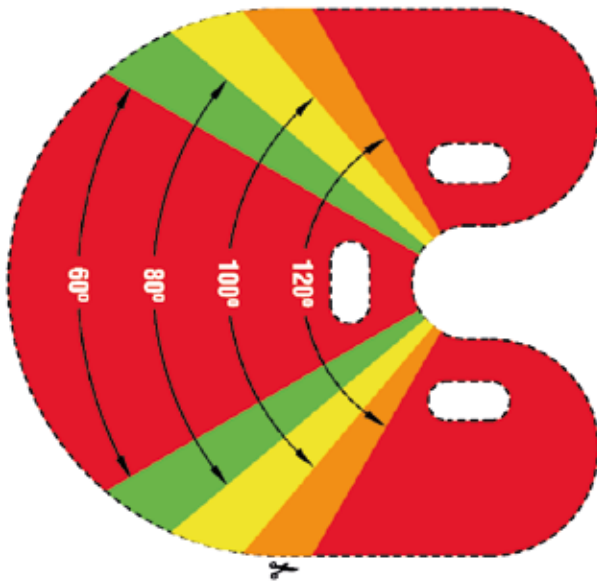
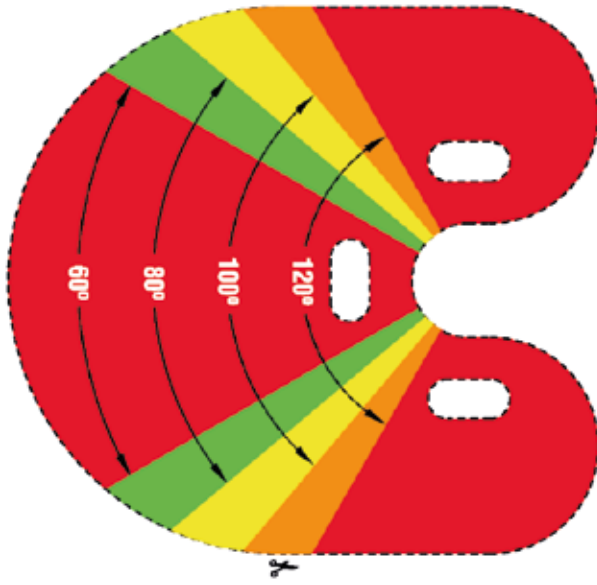

HKIAIR

SUSPENSION

HKI AIR SUSPENSION™
Air Suspension Technology and Performance.

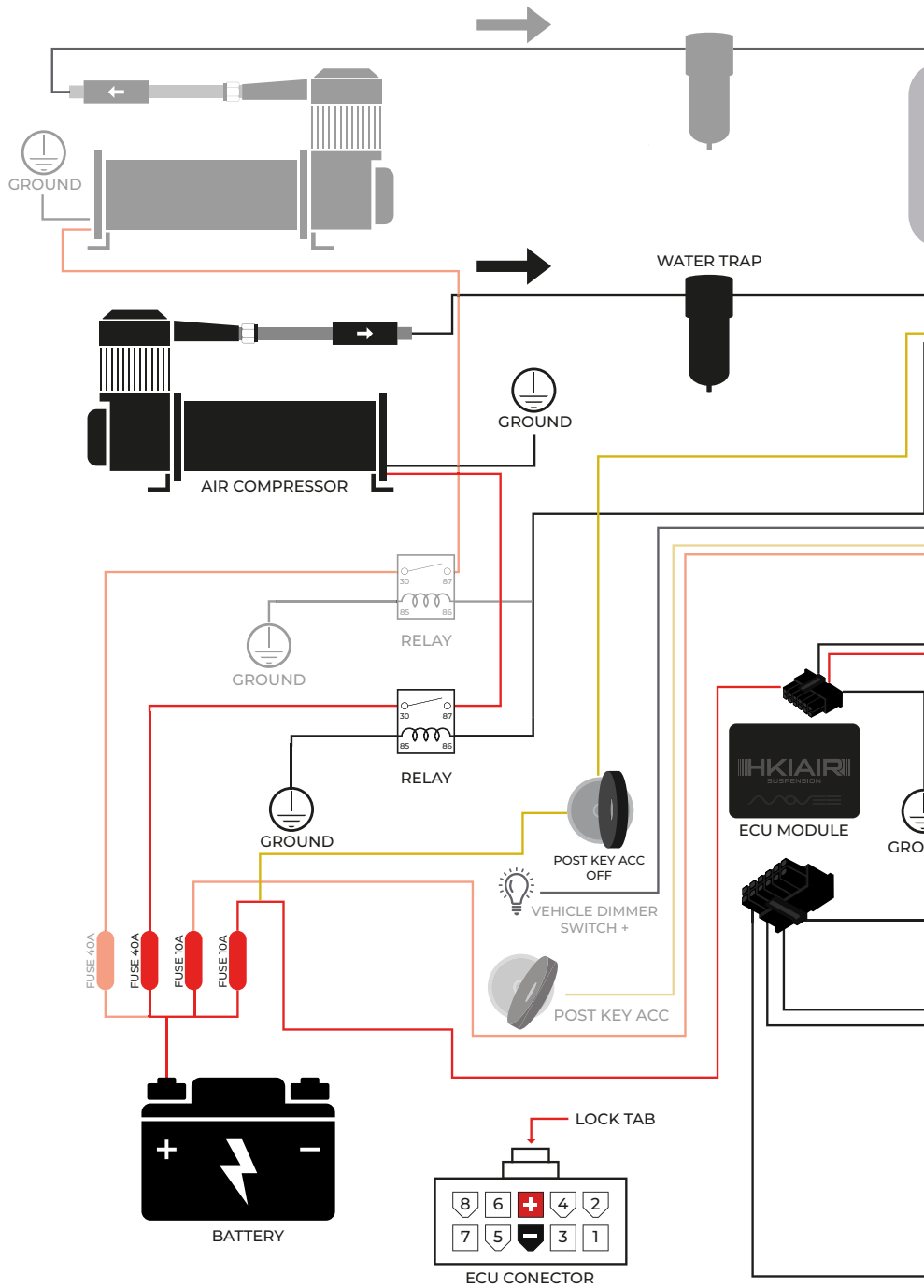

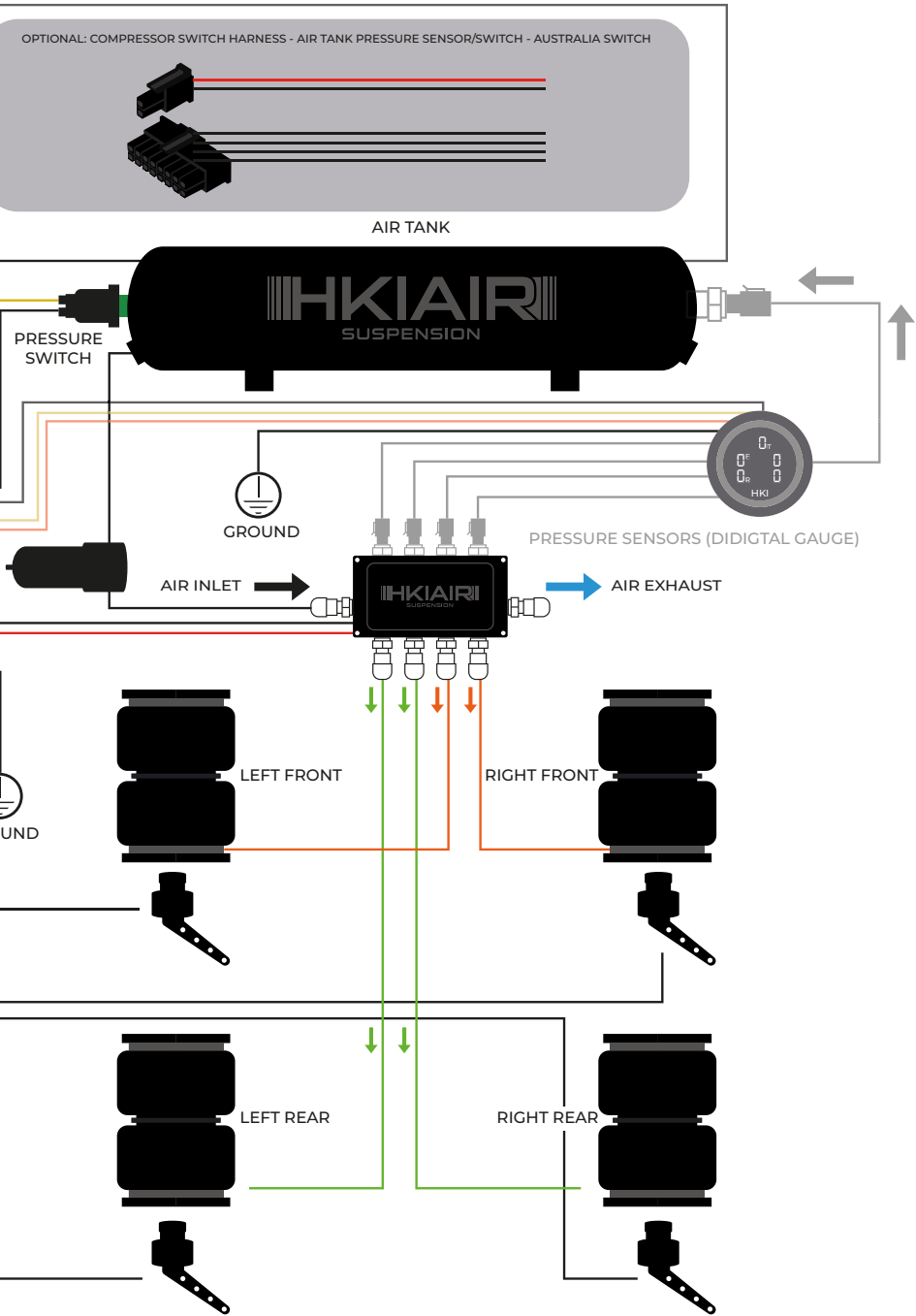



COMPRESSOR DIAGRAM



AVAILABLE ON

