

ASSEMBLY INSTRUCTIONS

INSTRUCCIONES DE ENSAMBLE

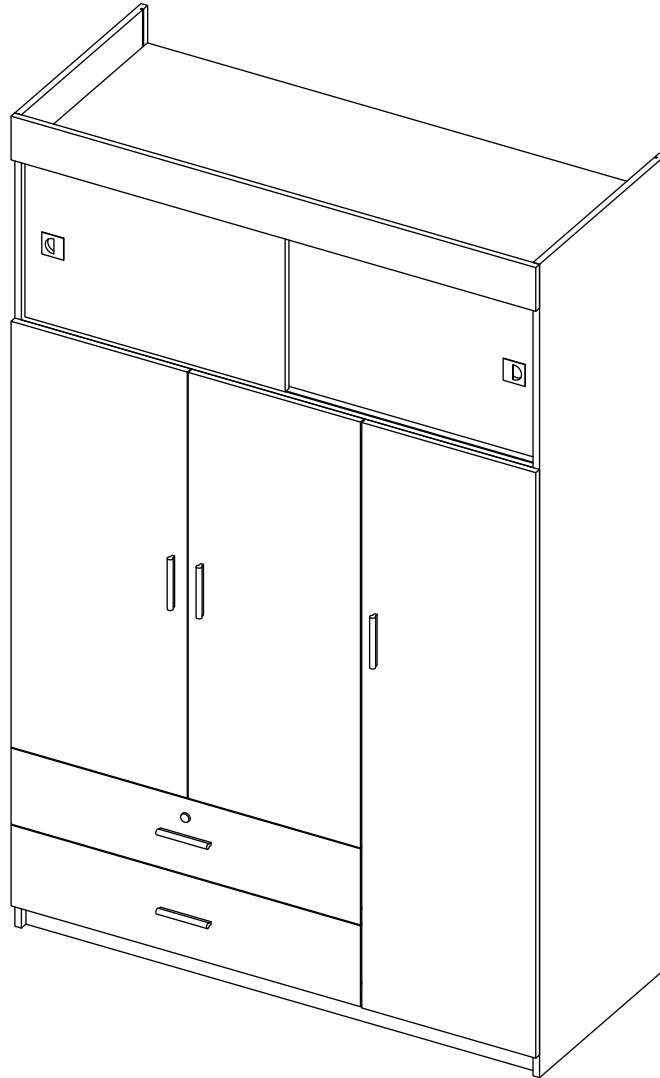

Height: 73,82 in

Alto: 187,5 cm

Width: 47,24 in

Ancho: 120 cm

Depth: 20,28 in

Fondo: 51,5 cm

LOT N°

**IF ANY PARTS ARE BROKEN OR
MISSING PLEASE CONTACT US**

AT: 1-888-391-01-66 /

customerservicetuhome@rta.com.co

**OUR CUSTOMER SERVICE TEAM WILL PROVIDE
YOU HELP TO RESOLVE ANY ISSUES IMMEDIATELY**

**CHILE MOBILE ARMOIRE
ARMARIO MÓVIL CHILE**



IMPORTANT RECOMMENDATIONS

Do not paint the cabinet.

The cabinet **MUST** be used exclusively indoors, do not expose to direct sun.

Clean metallic hardware with a dry cloth.

Do **NOT** overload the cabinet (see suggested loads).

Do not hit or hammer the cabinet (just when indicated).

Clean with a slightly damp cloth, use gentle soaps.

Do not drag, lift and move between two people.

Avoid direct contact with water, fire or exposure to heat sources.

RECOMENDACIONES IMPORTANTES

No pintar el mueble.

El mueble debe ser usado únicamente en interiores, no exponer al sol directo.

Limpiar los herrajes metálicos con un paño seco.

NO sobrecargar el mueble (ver las cargas sugeridas).

No golpear ni martillar el mueble (solo cuando se indique).

Limpiar con un paño ligeramente húmedo, usar jabones suaves.

No arrastre el mueble, levántelo entre dos personas.

Evite el contacto directo con el agua, el fuego o la exposición a fuentes de calor.



WARNING

Never allow children to climb or manipulate the cabinet, furniture tip over can cause serious injuries or death.



ADVERTENCIA

Nunca permita que los niños escalen o manipulen el mueble, la caída de este puede provocar lesiones graves o la muerte.

INDEX

ÍNDICE

Assembly Hardware	4-5	Herrajes para Armado.....	4-5
Assembly Parts	6	Piezas de Armado.....	6
Suggested Loads.....	7	Cargas Sugeridas.....	7
Assembly Recommendations.....	7	Recomendaciones de Ensamble.....	7
Assembly Steps	8-29	Pasos de Armado.....	8-29
Warranty.....	30	Garantía	30

REQUIRED TOOLS*

HERRAMIENTAS NECESARIAS*

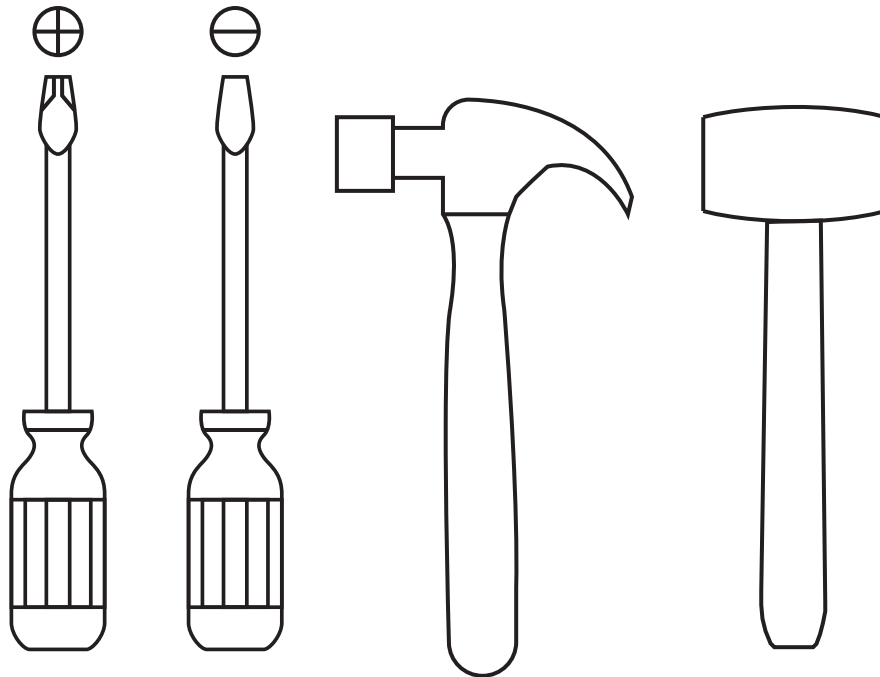

*Not included, and not shown actual size.

*No incluidas y no se muestran en tamaño real.

ASSEMBLY HARDWARE

HERRAJES PARA ARMADO

Please check that the hardware content is correct. If any item is missing, please call to our customer service line.

Compruebe que el contenido de los herrajes sea el correcto. En caso de que falte alguna pieza, por favor llame a nuestra línea de atención al cliente.

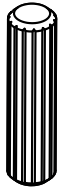

x74

Wood Dowel
Tarugo

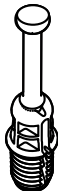

x50

Spreading Bolt
Perno Minifix



x50

Minifix Cams
Minifix



x54

Cover Caps
Tapa Adhesiva
Minifix

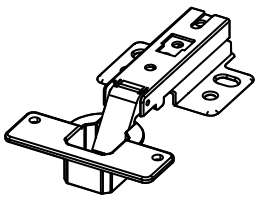

x5

Full Overlay Hinge
(Screws Included)
Bisagra Parche
(Incluye tornillos)

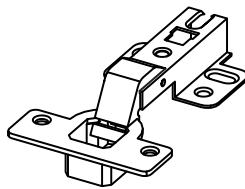

x2

Half Overlay Hinge
(Screws Included)
Bisagra Semi Parche
(Incluye tornillos)

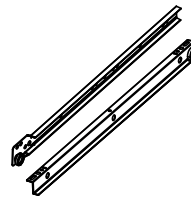

x2

Drawer Slides
(Screws Included)
Riel
(Incluye tornillos)



x38

Flat Head Screw
Tornillo Lámina

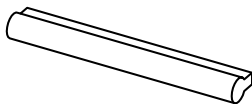

x5

Handle
(Screws Included)
Manija
(Incluye tornillos)



x12

2" Drywall Screw
Tornillo de
Ensamble 2"



x2

Handle
Manija de incrustar

Hardware items are NOT shown actual size.

Los herrajes no se muestran en el tamaño real.

ASSEMBLY HARDWARE

Please check that the hardware content is correct. If any item is missing, please call to our customer service line.

HERRAJES PARA ARMADO

Compruebe que el contenido de los herrajes sea el correcto. En caso de que falte alguna pieza, por favor llame a nuestra línea de atención al cliente.

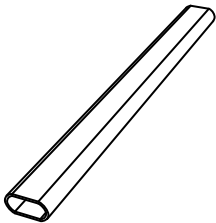

x1

Closet Rod
Tubo Ovalado

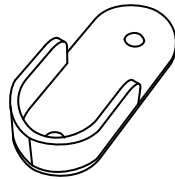

x2

Rod Support
Soporte Tubo

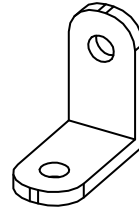

x3

Wide Brace
Cantонера

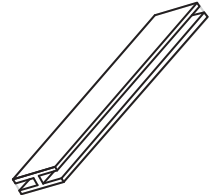

x1

Guide Profile
Perfil H

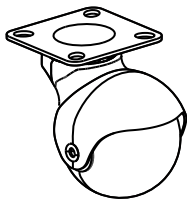

x6

Wheel Castors
Rodachina Bola
Maciza

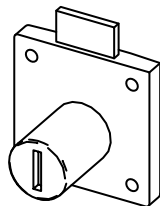

x1

Lock With Key
(Screws Included)
Cerradura de Incrustar
(Incluye tornillos)

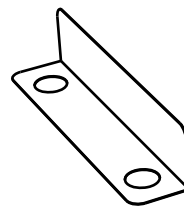

x1

Lock Brace
Platina Cerradura

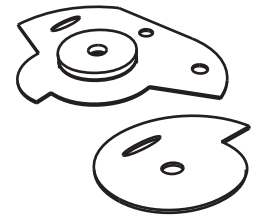

x1

Sliding Door
(Screws Included)
Corredera D-25
Ducasse
(Incluye tornillos)



x4

Door bumpers
Tope puerta

Hardware items are NOT shown actual size.

Los herrajes no se muestran en el tamaño real.

ASSEMBLY PARTS

PIEZAS DE ARMADO

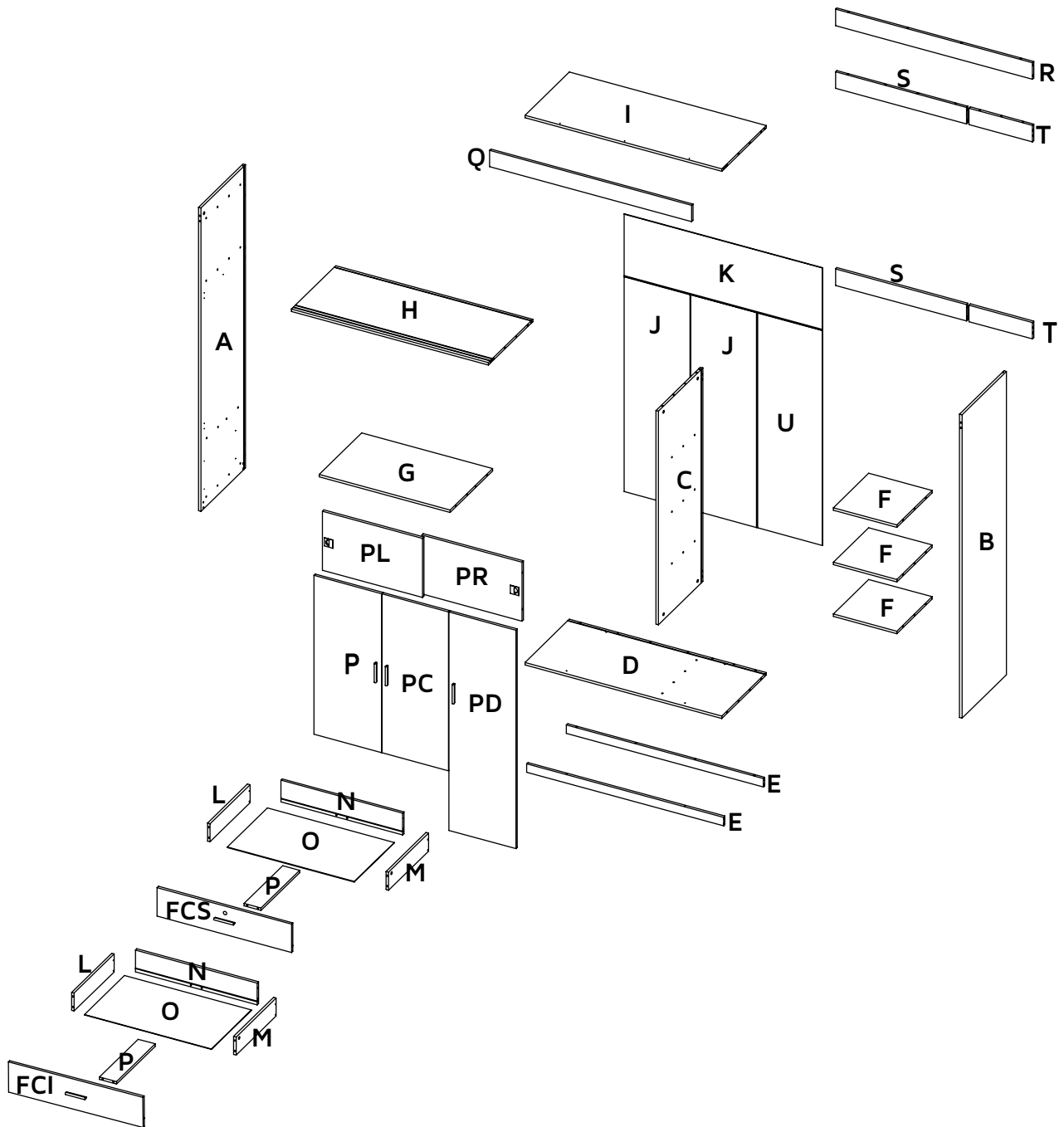

A - x1	F - x3	I - x1	N - x2	PD - x1	S - x2
B - x1	FCS - x1	J - x2	O - x2	PC - x1	T - x2
C - x1	FCI - x1	K - x1	P - x2	PI - x1	U - x1
D - x1	G - x1	L - x2	PR - x1	Q - x1	
E - x2	H - x1	M - x2	PL - x1	R - x1	

MAX SUGGESTED LOADS

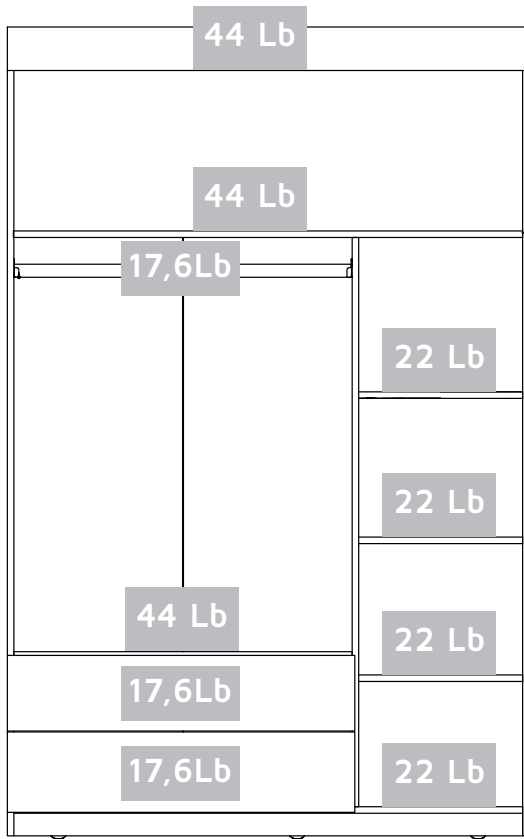

CARGAS MÁXIMAS SUGERIDAS

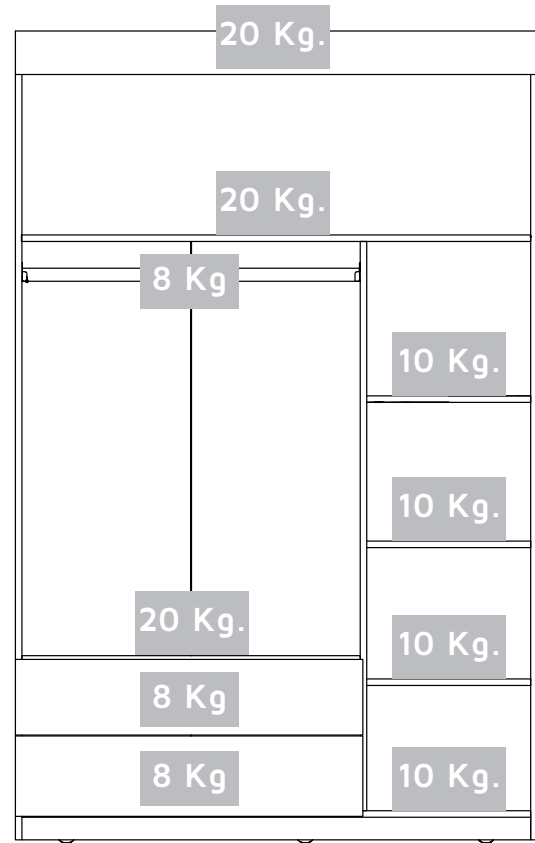

ASSEMBLY RECOMMENDATIONS

Two people are recommended to assemble the product.

Assemble the cabinet on a flat, smooth surface, preferably on a carpeted floor or the carton box of the product.

Carefully read the assembly instructions and identify every wood and hardware part before start assembling the cabinet.

RECOMENDACIONES DE ENSAMBLE

Ensamble el mueble entre dos personas.

Ensamble el mueble sobre una superficie plana y lisa, preferiblemente sobre un tapete o el cartón de la caja

Lea cuidadosamente las instrucciones e identifique todas las piezas y herrajes antes de empezar a armar el mueble.

1

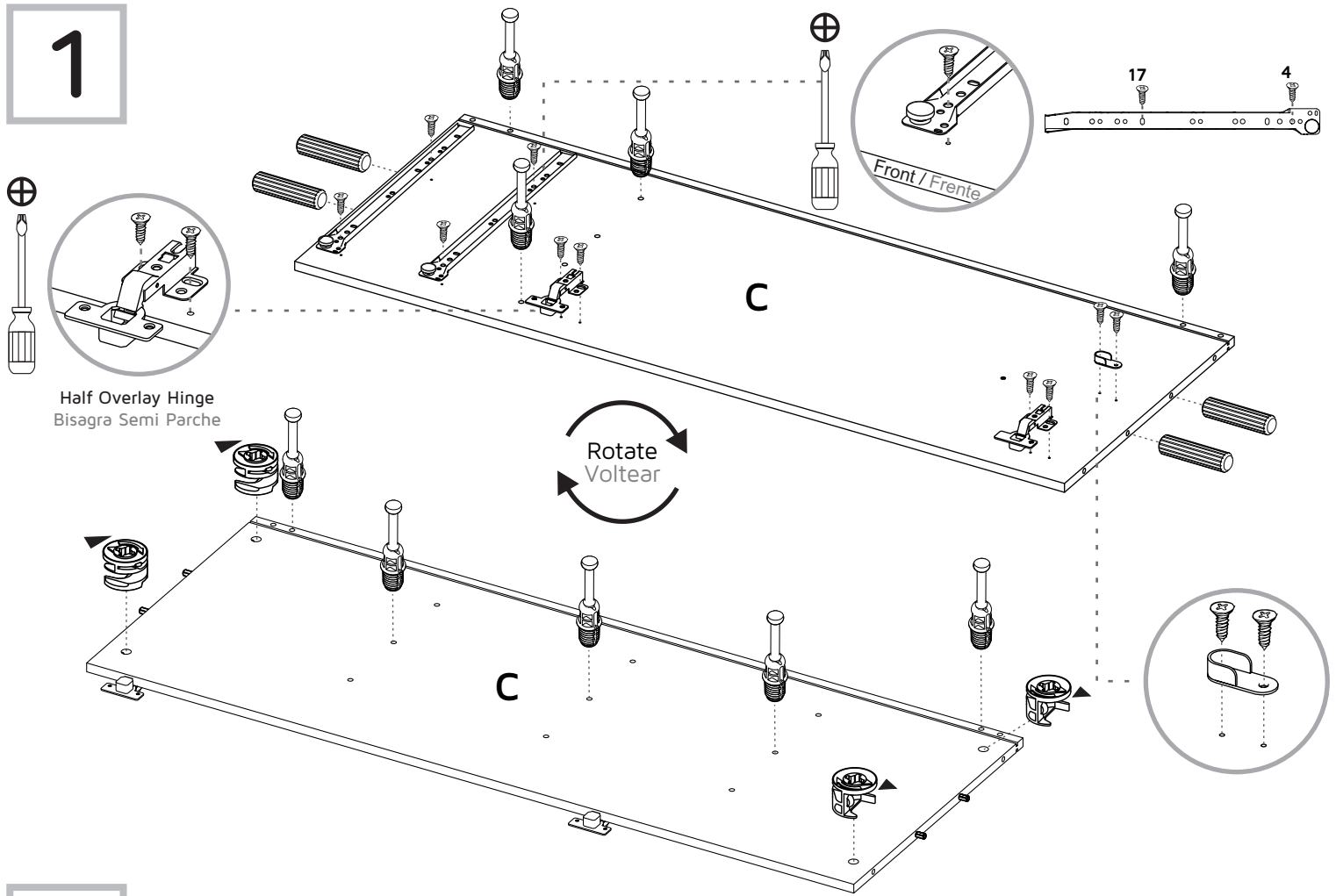

2

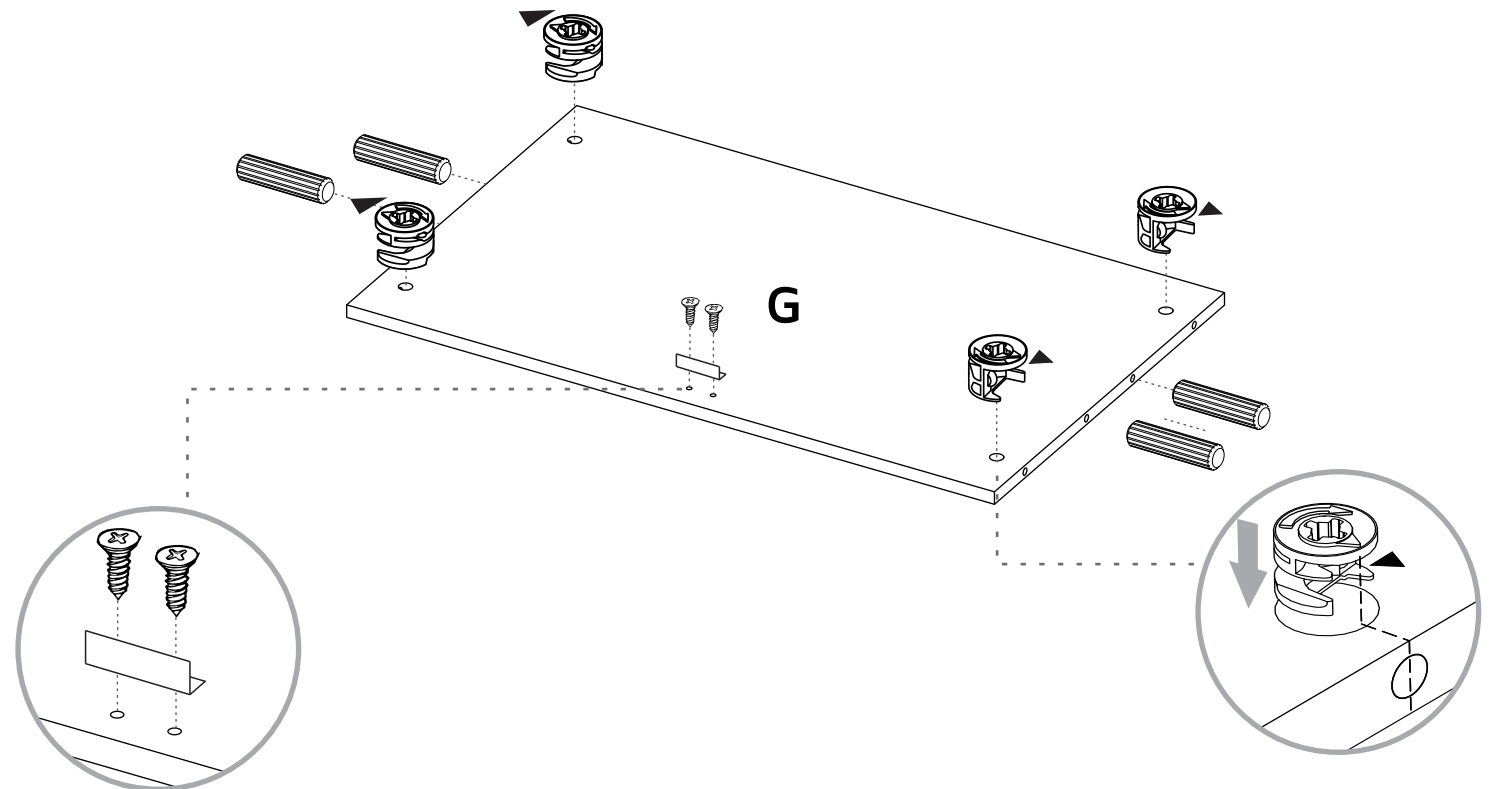

3

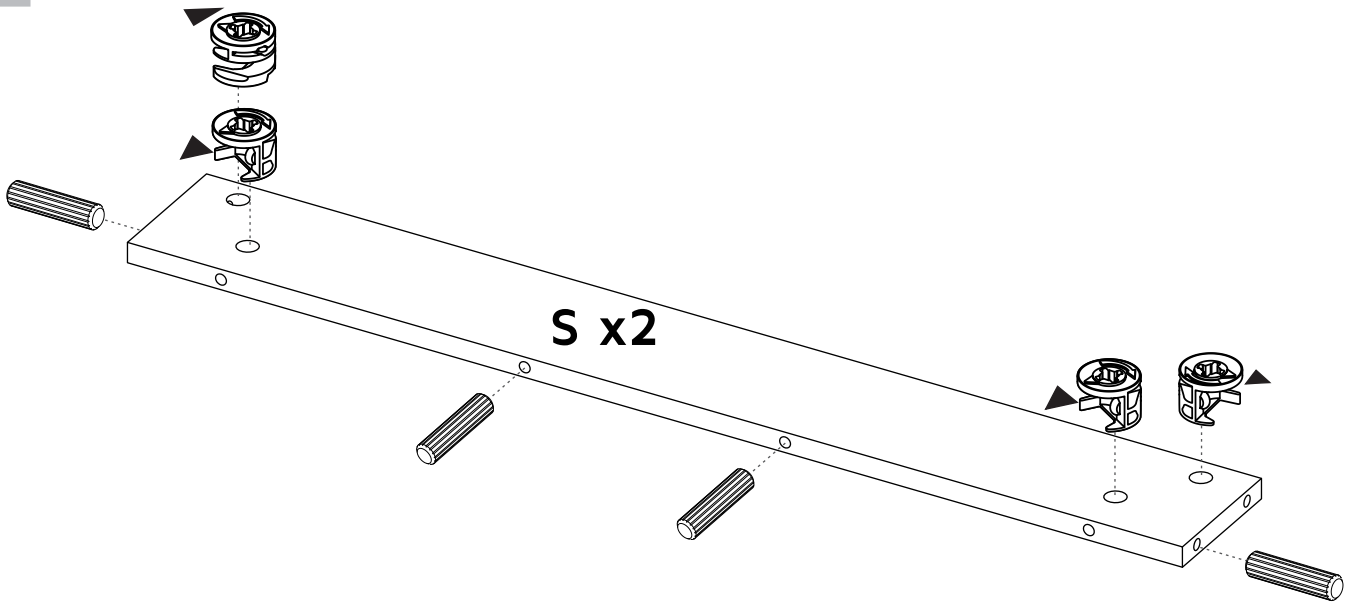

4

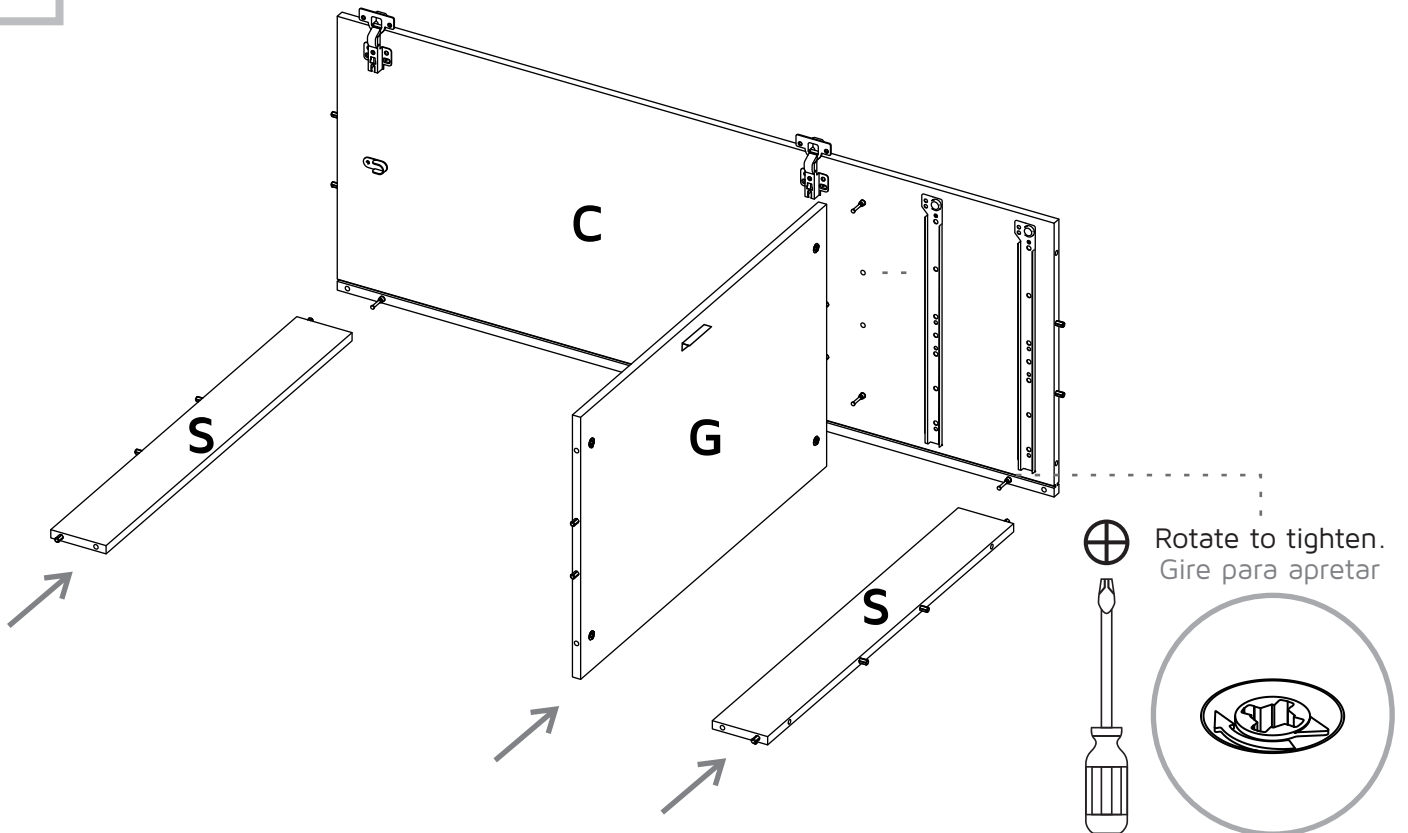

5

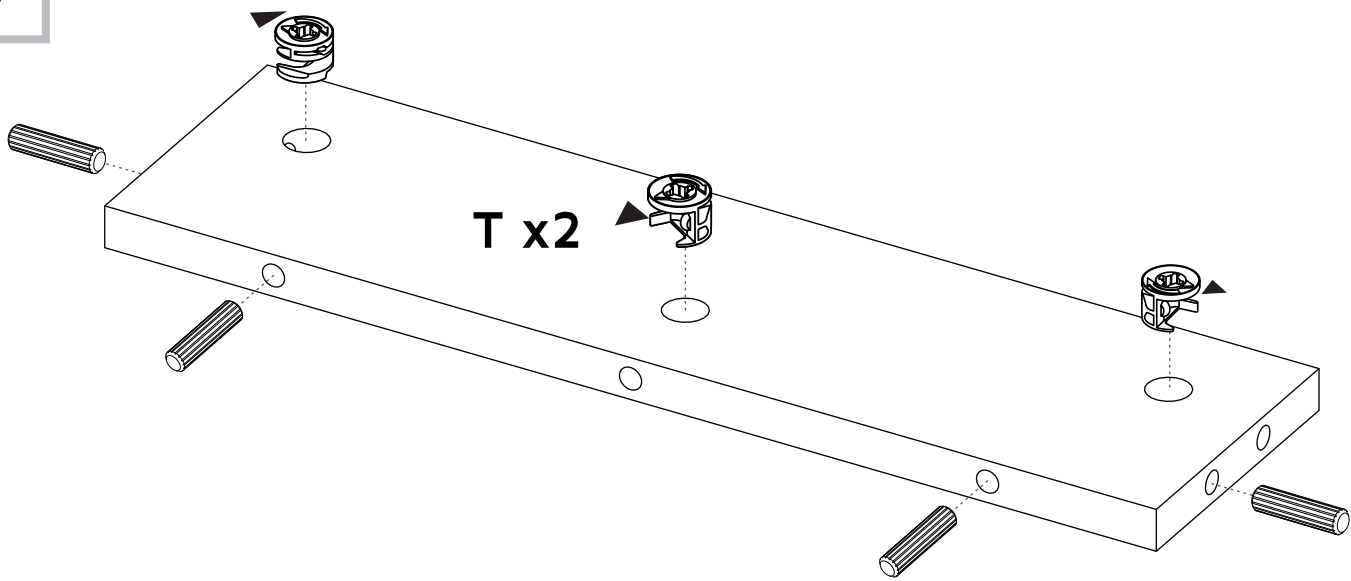

6

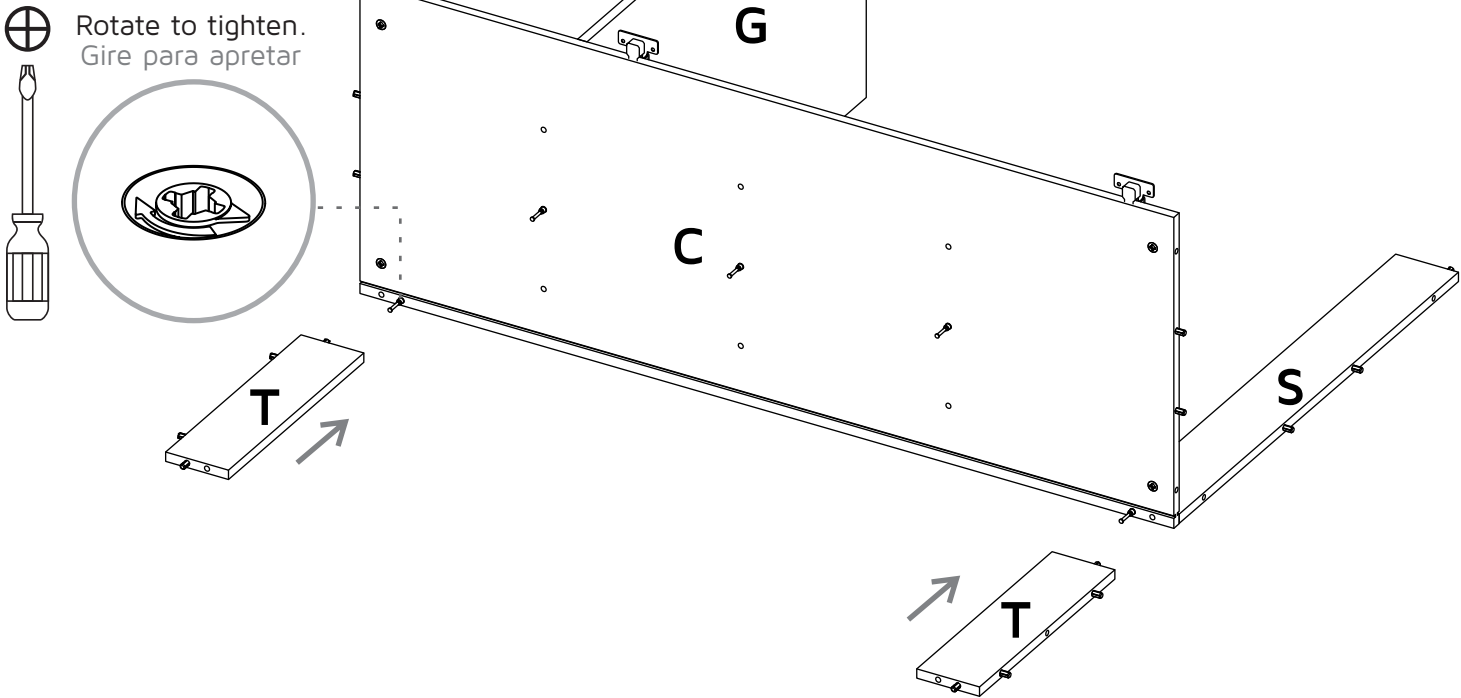

7

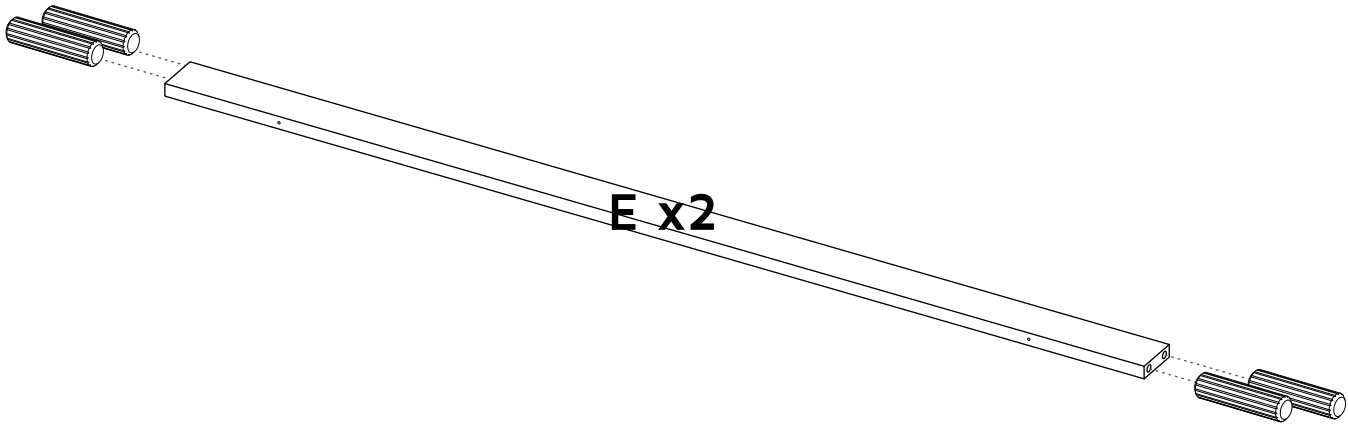

8

Consider the perforations in part "A" to install the wheel castors and choose the correct wheel hole to put them into place/ Considere las perforaciones en la pieza "A" para la instalación de las rodachinas y elija el orificio correcto de la rodachina para colocarlas en su lugar.

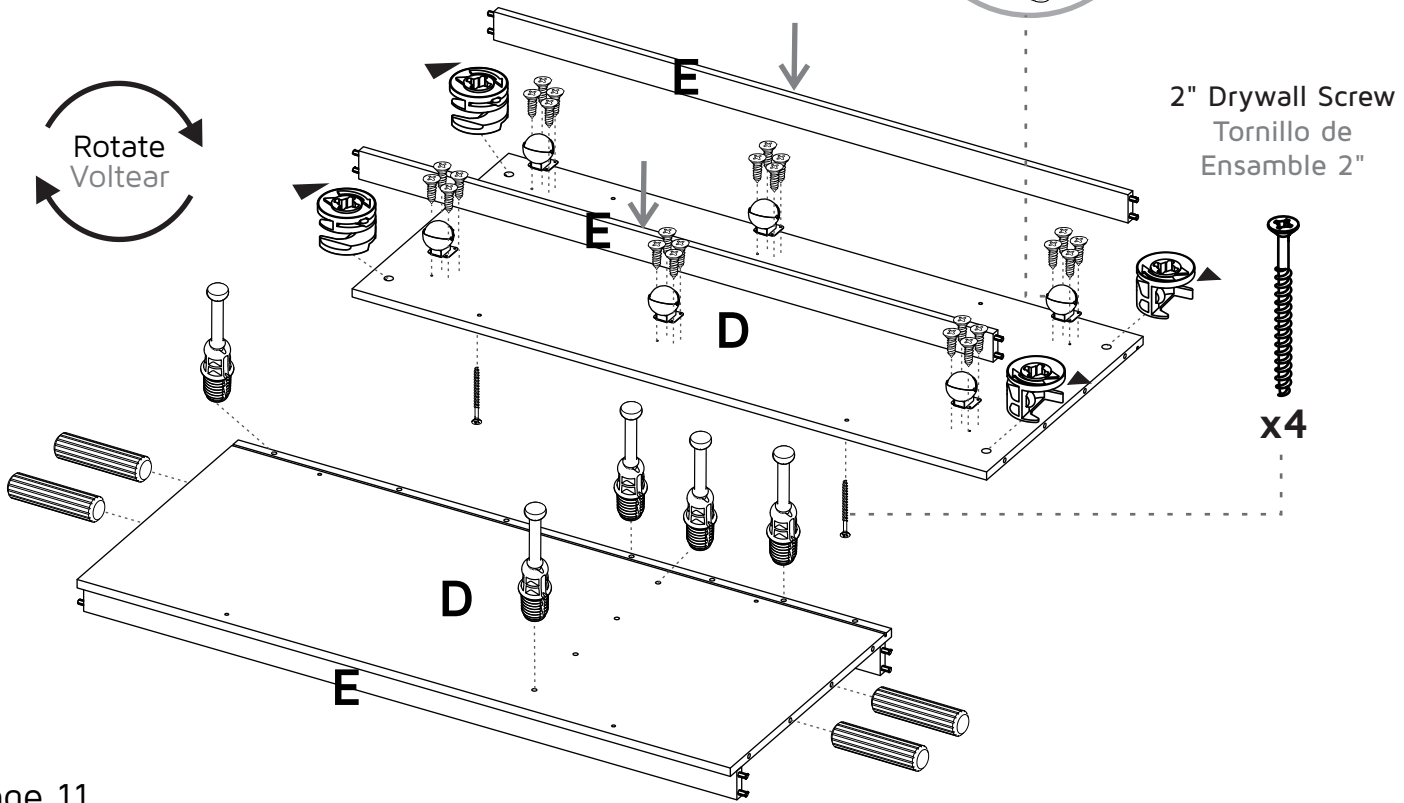
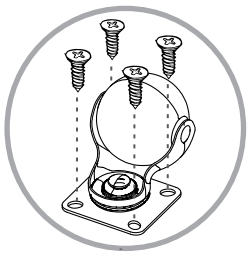

9

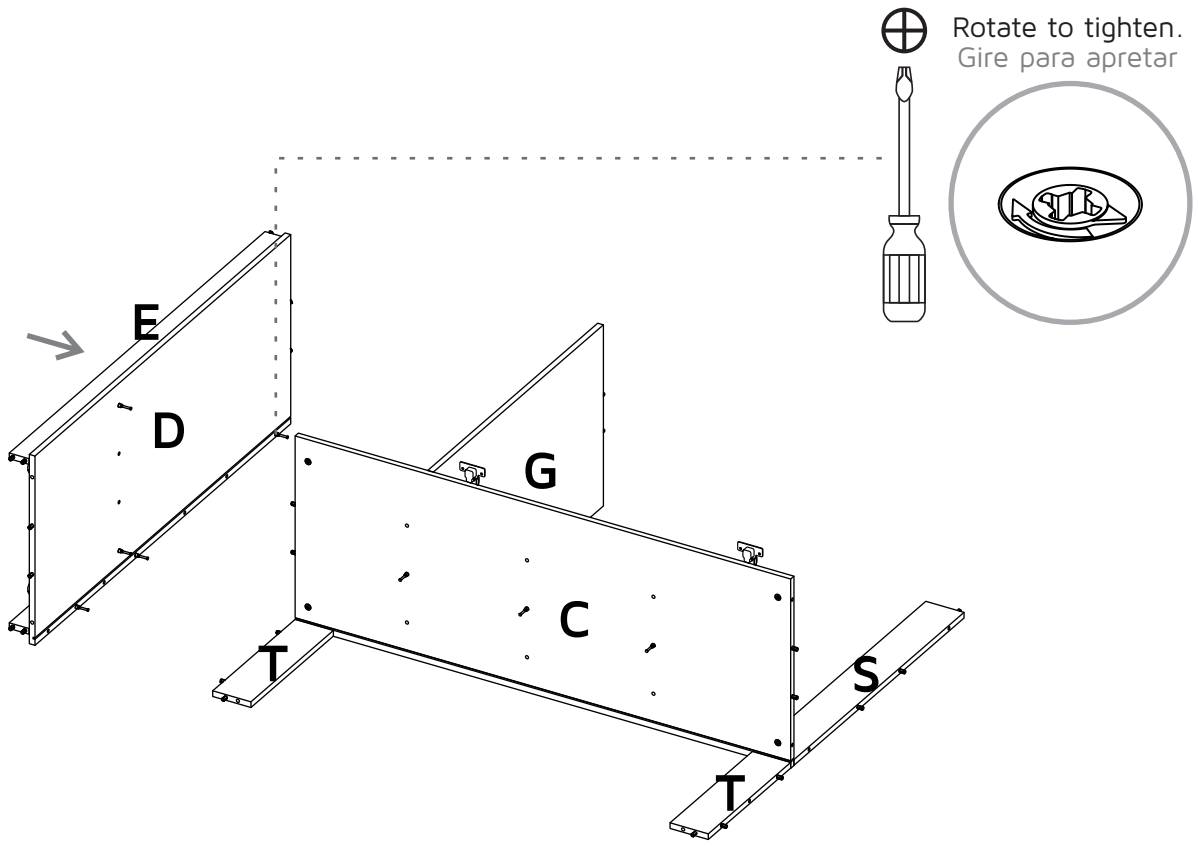

10

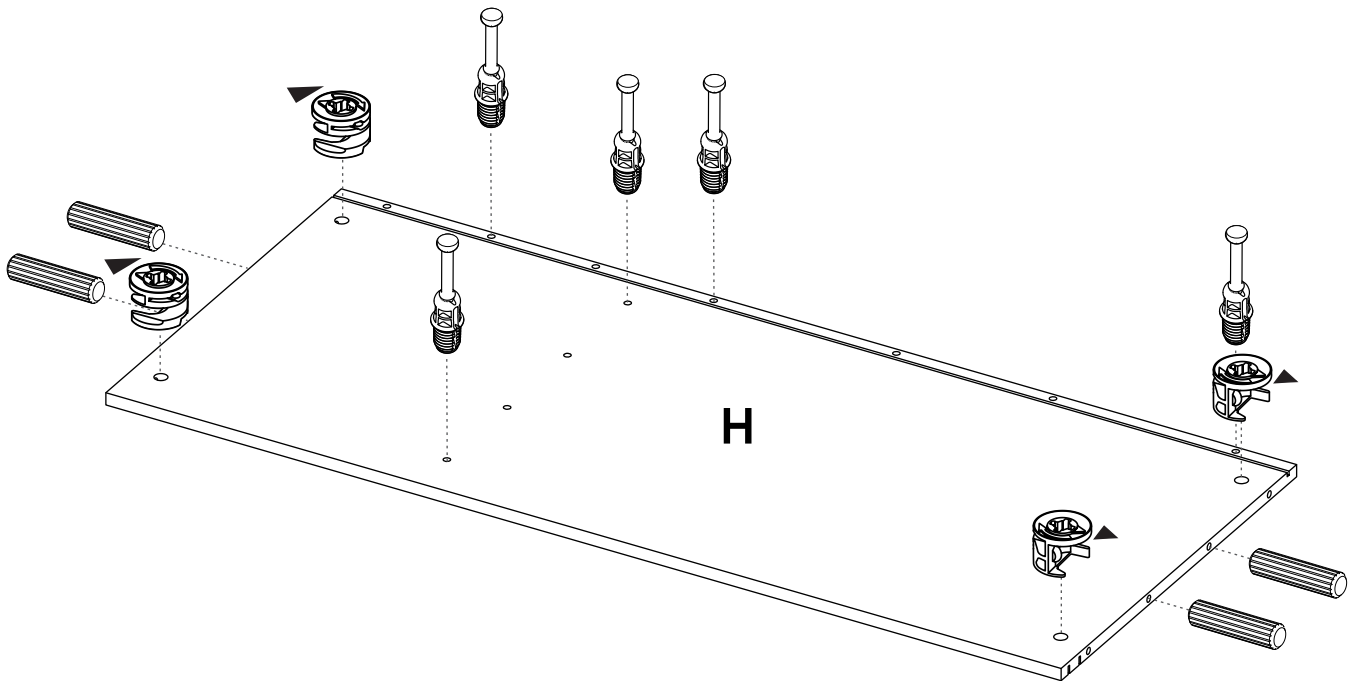

11

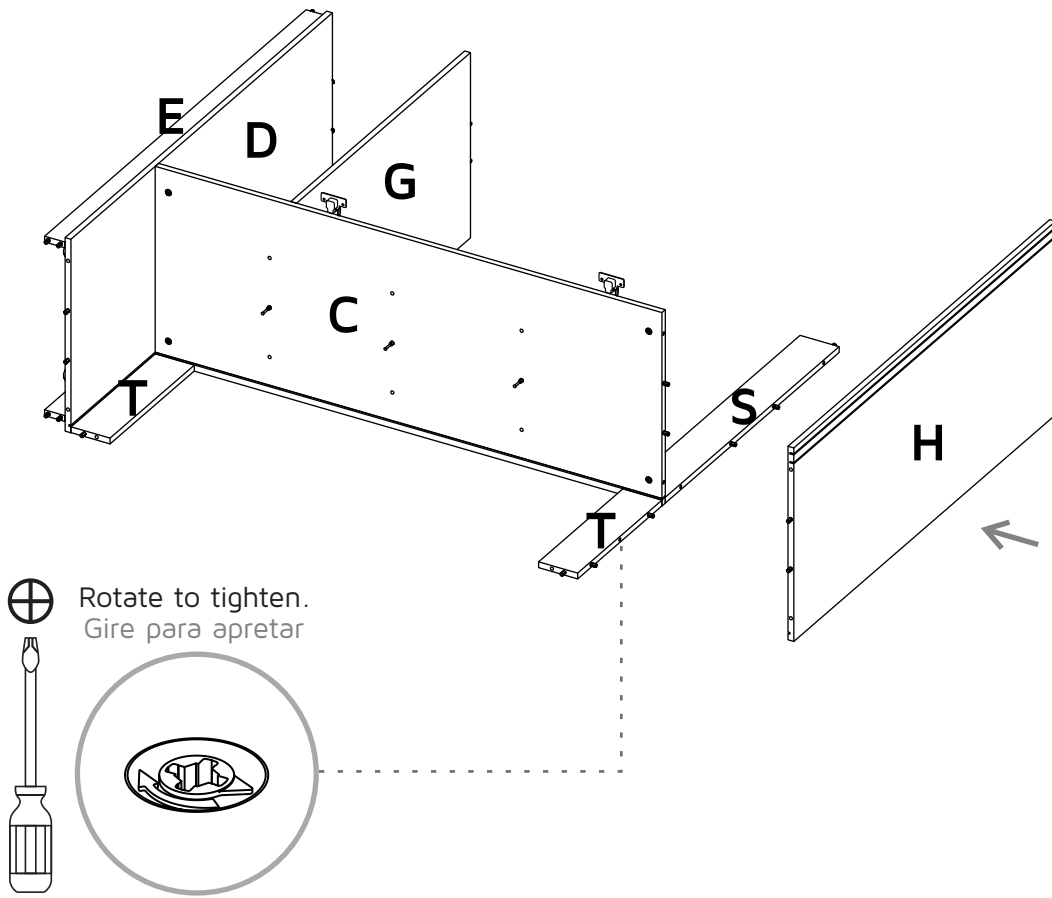

12

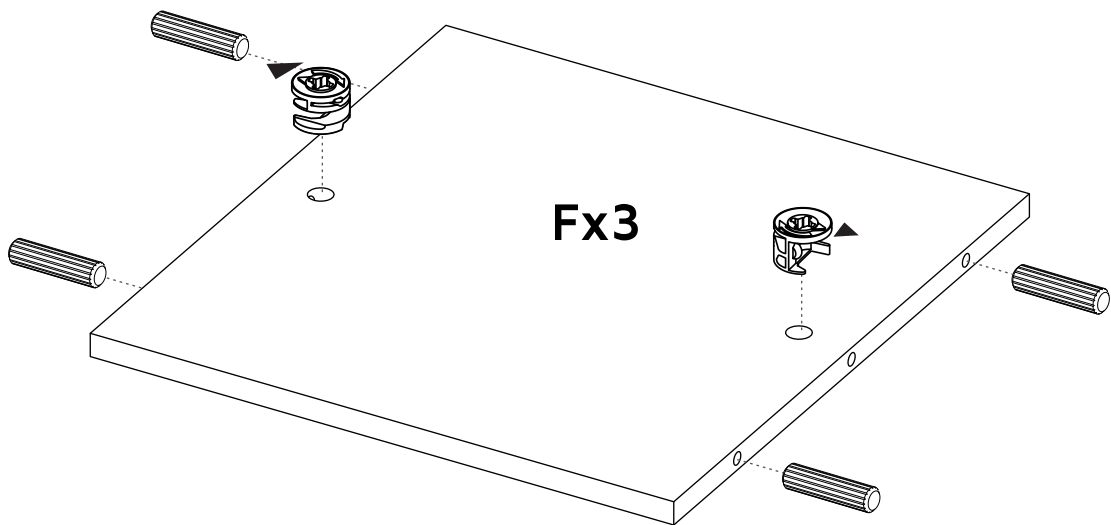

13

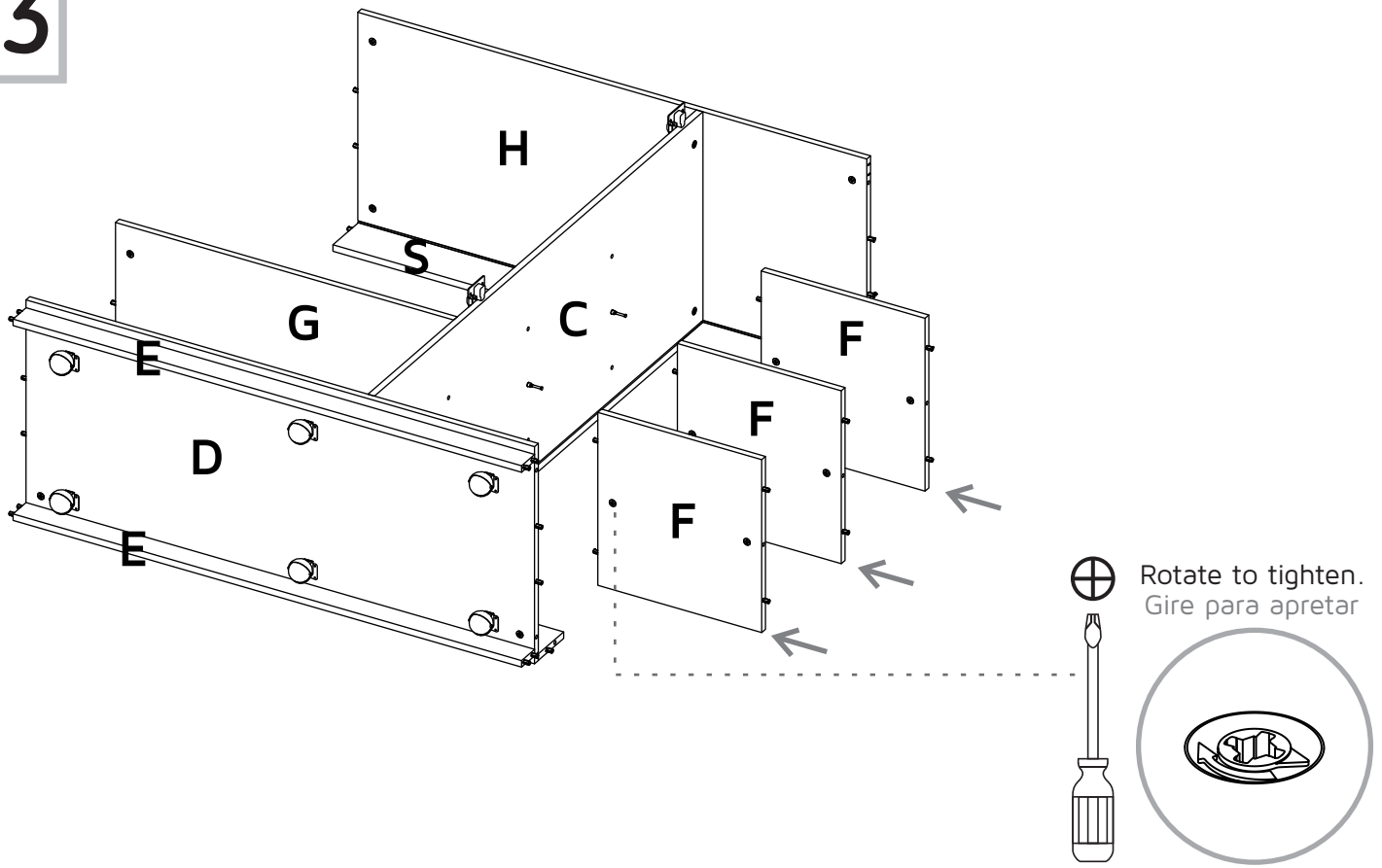

14

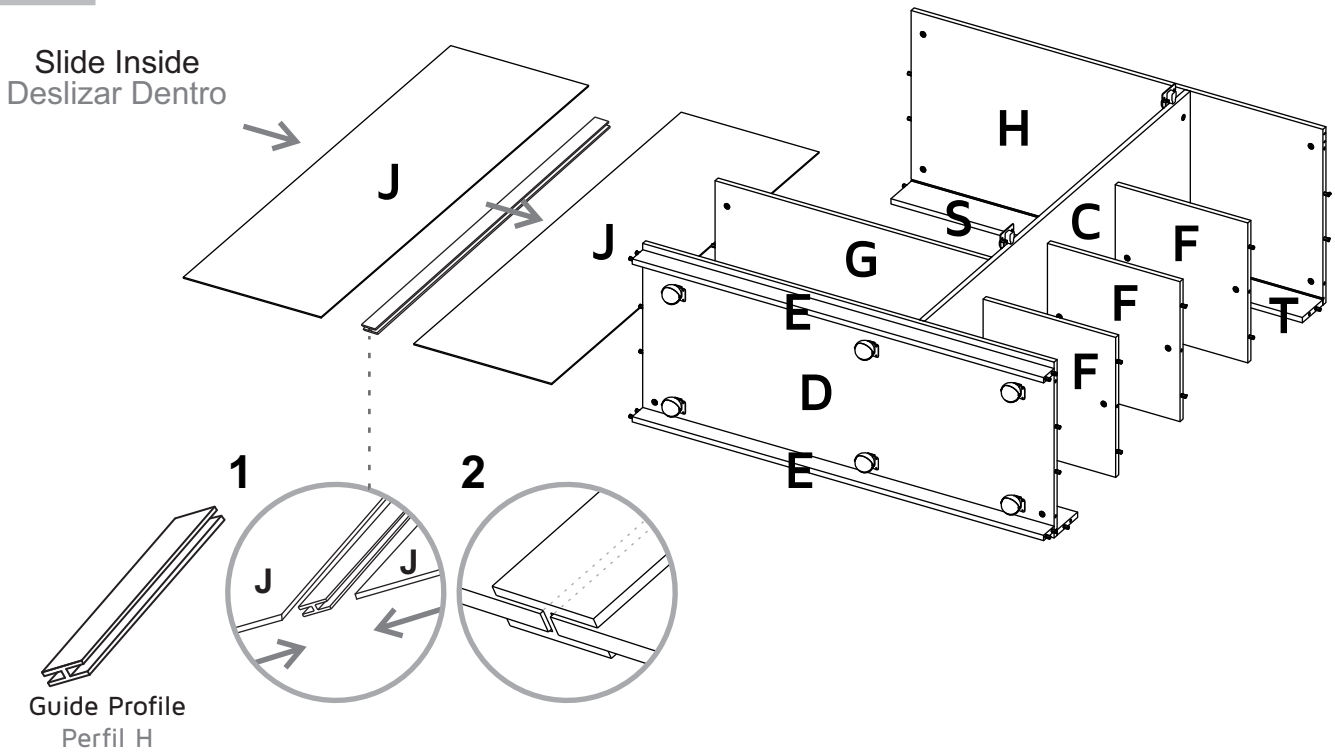

15

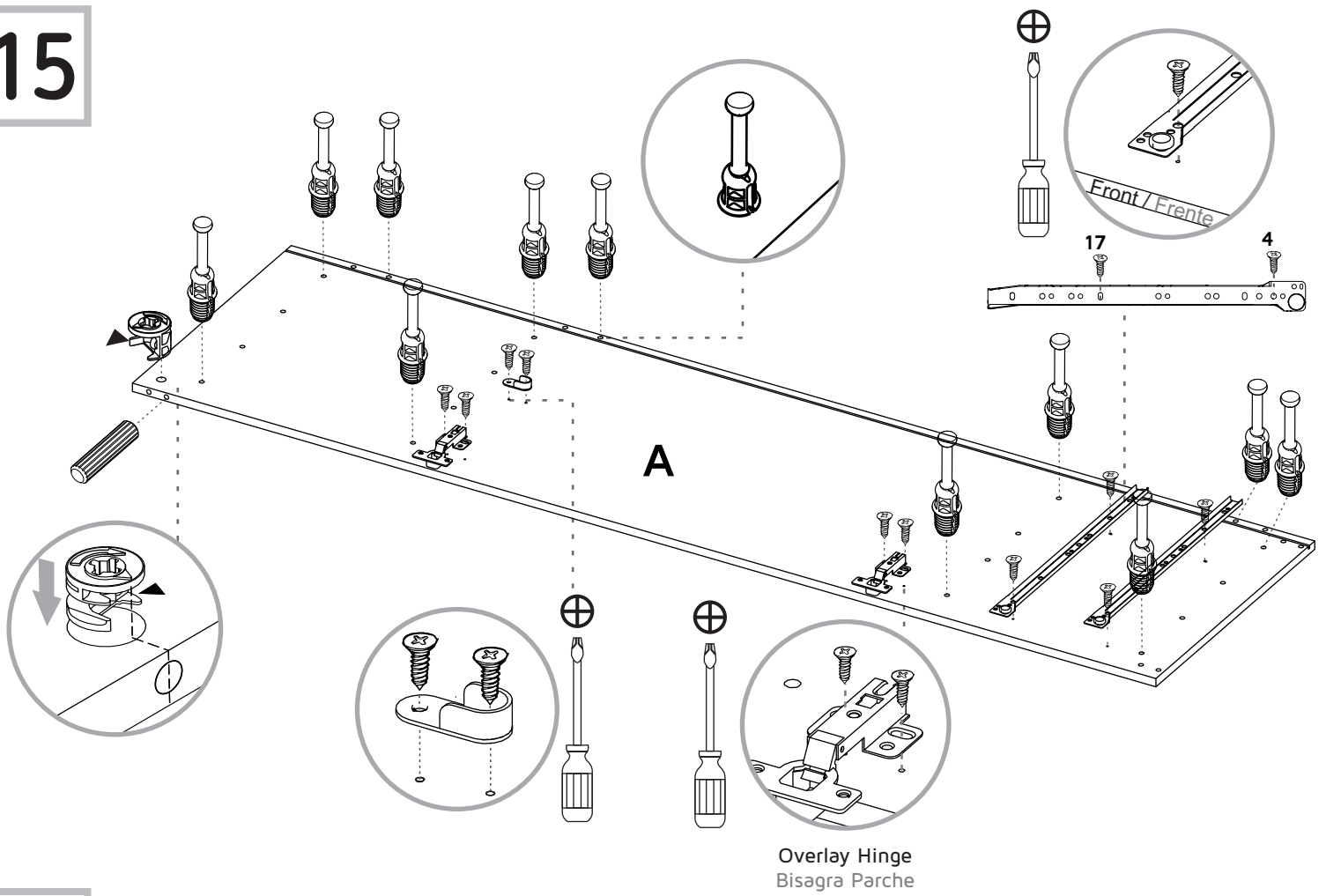

16

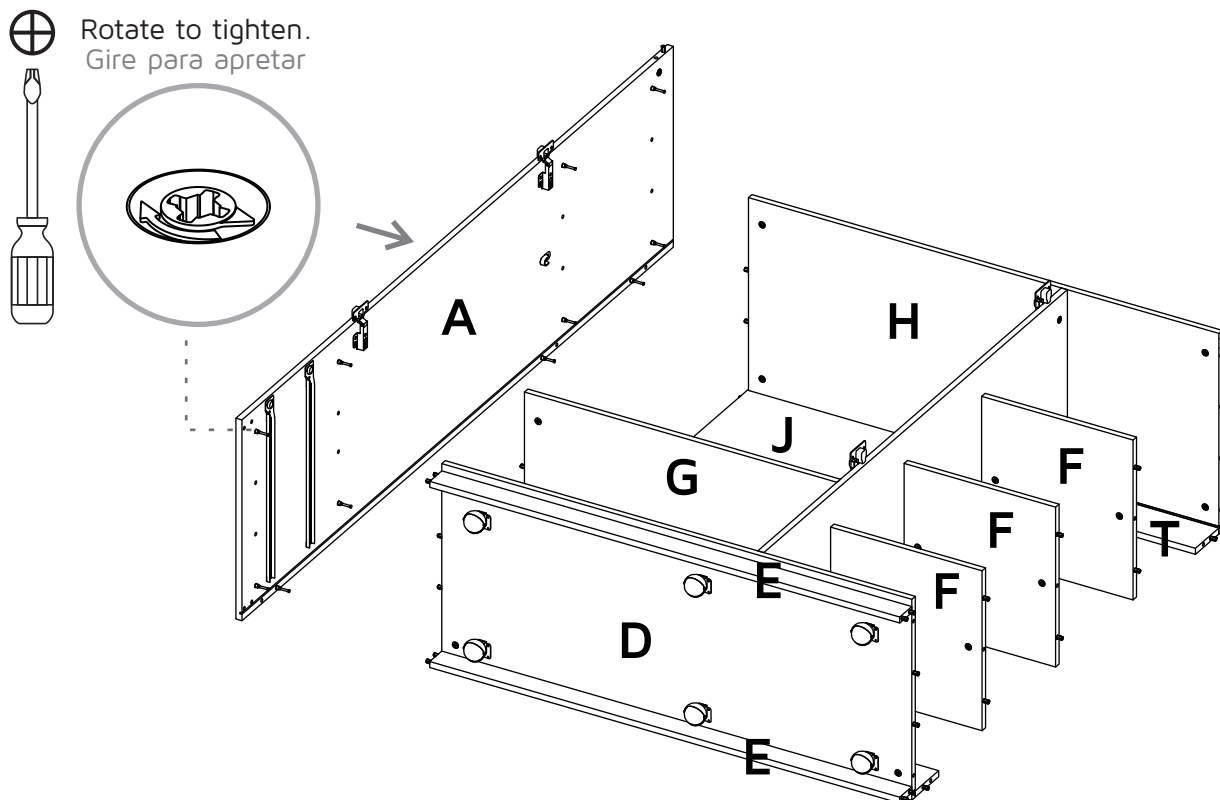

17

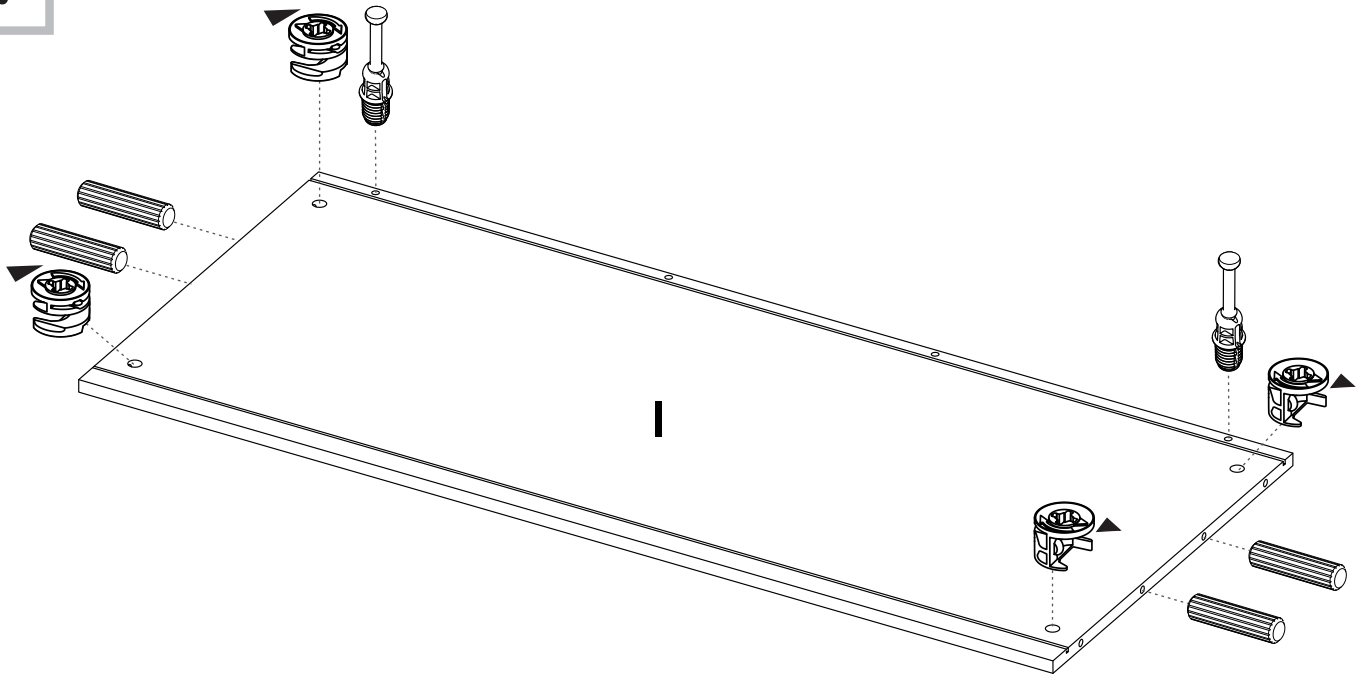

18

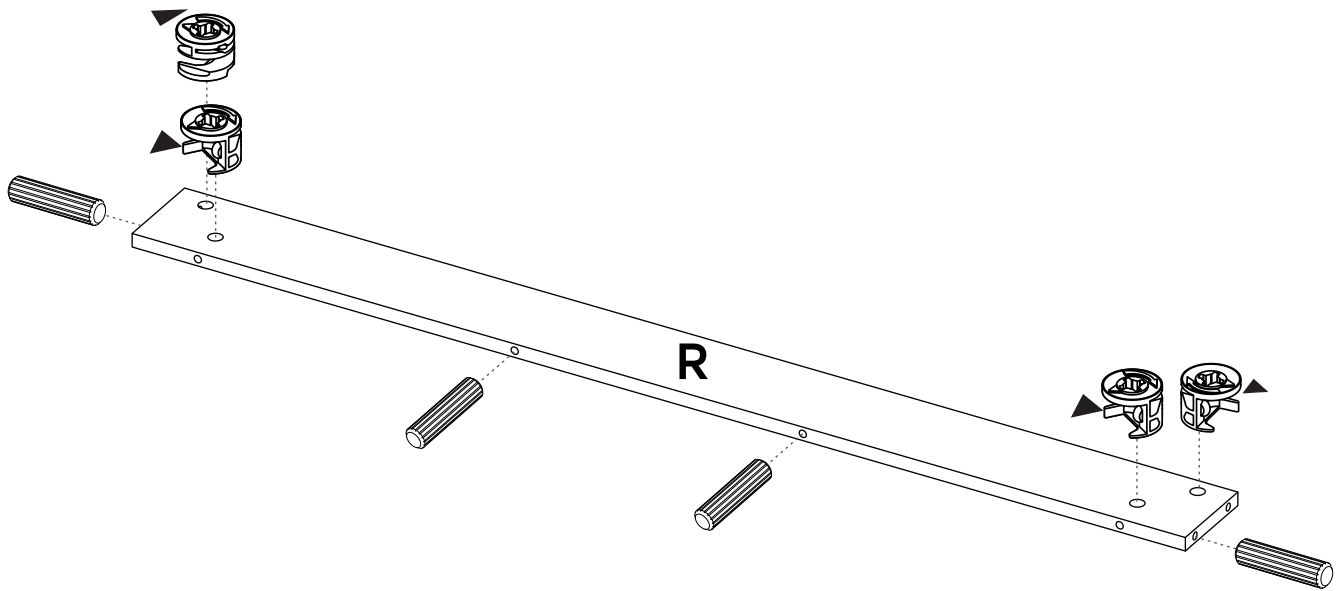

19

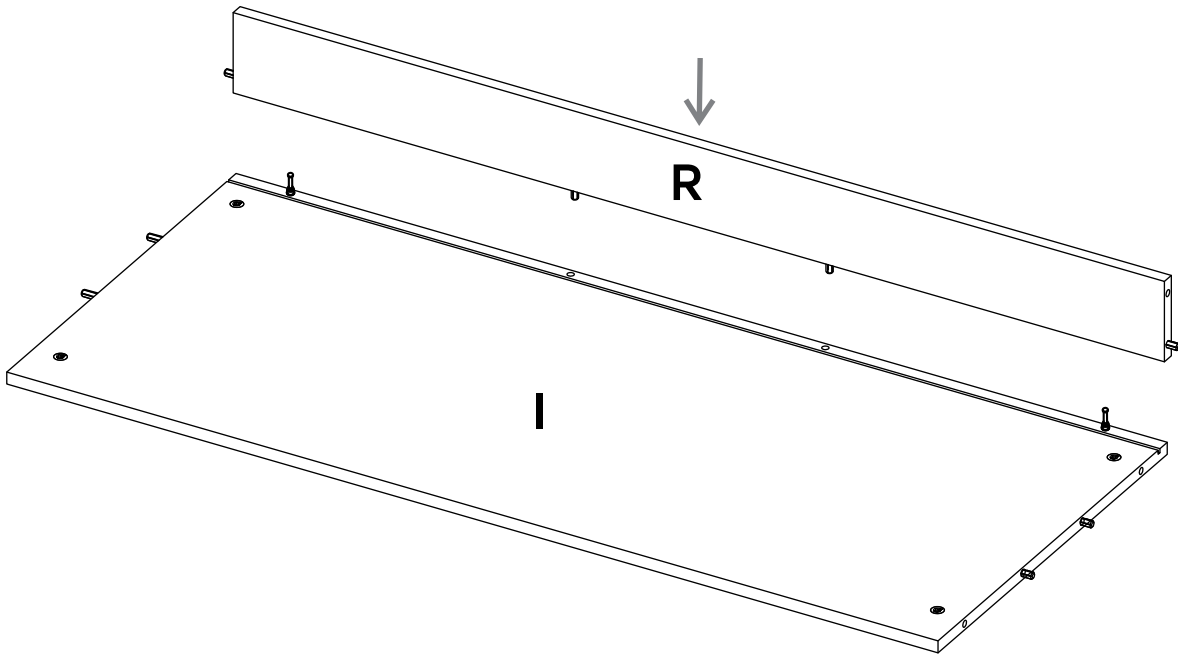

20

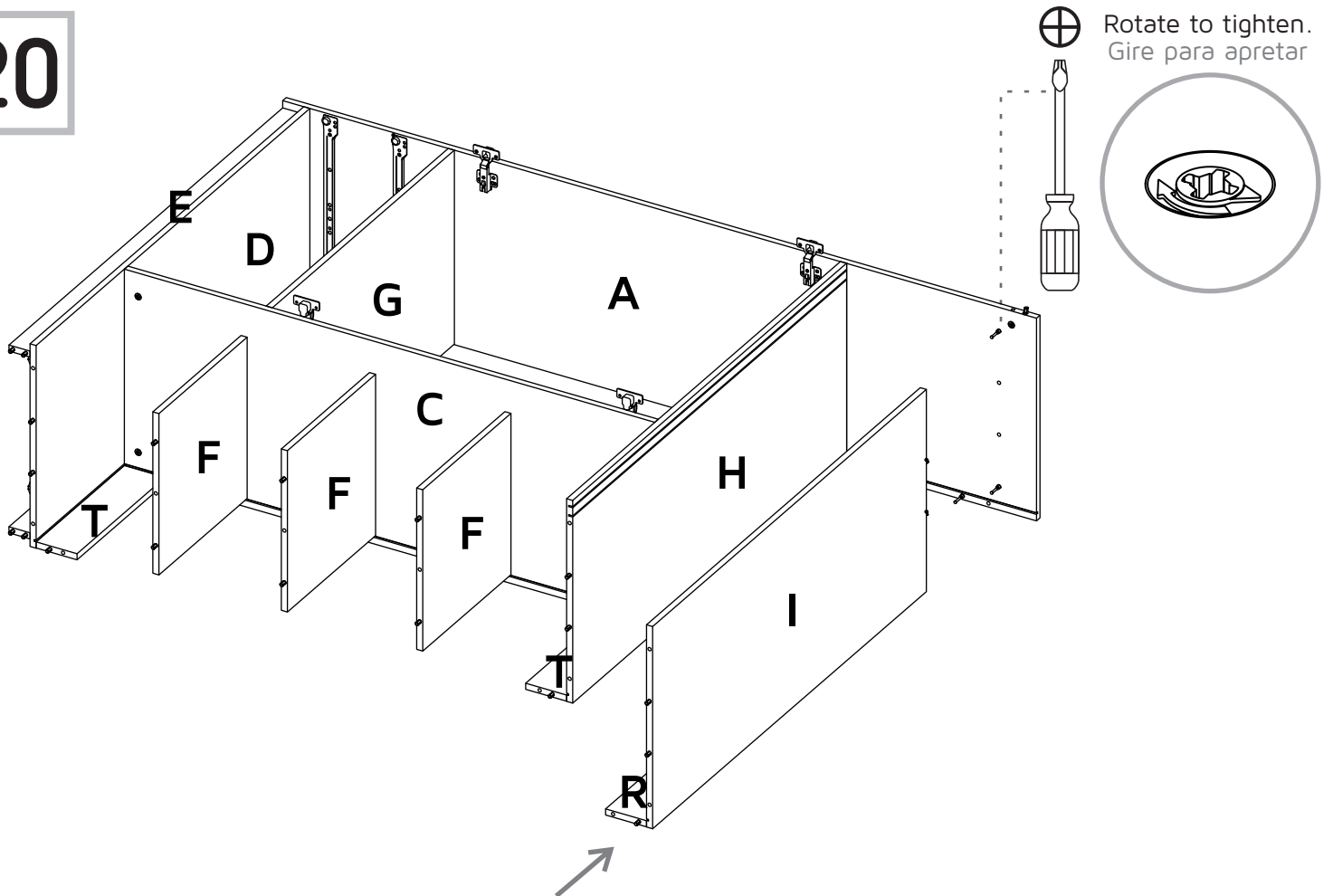

21

Slide Inside
Deslizar Dentro

Carefully Flip
The Furniture
Voltear el mueble
cuidadosamente

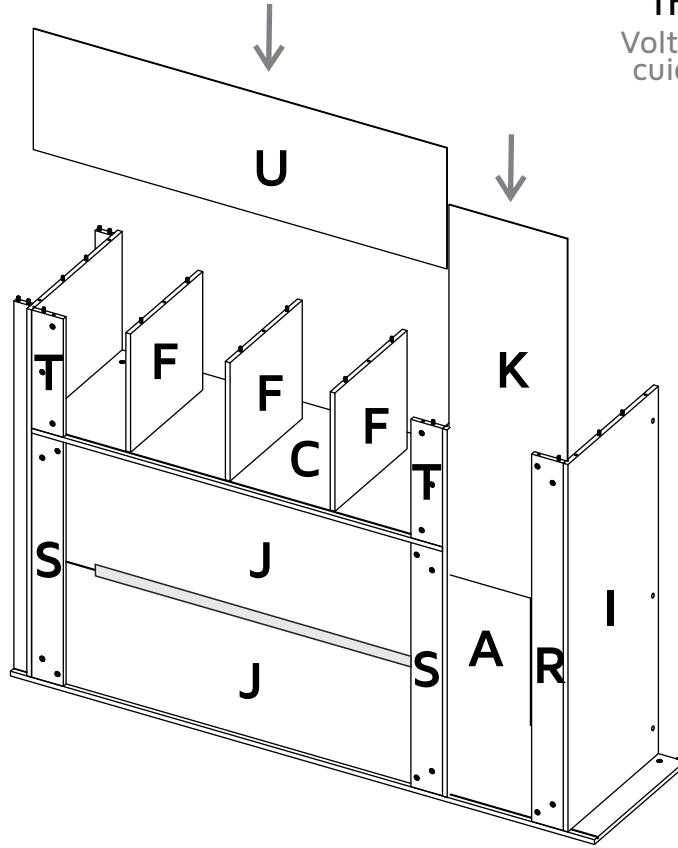

22

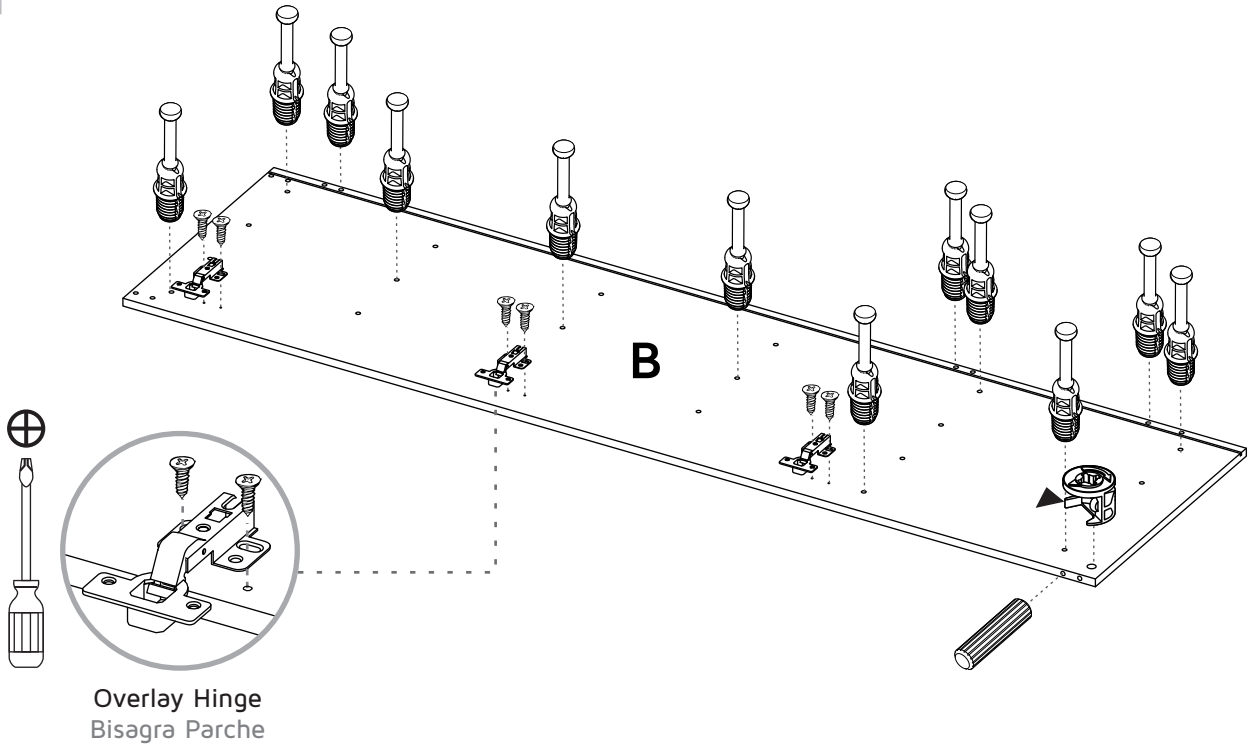

Overlay Hinge
Bisagra Parche

23

It is recommended to put the piece in place with the help of another person.

Se recomienda poner la pieza en su lugar con la ayuda de otra persona

Rotate to tighten.
Gire para apretar

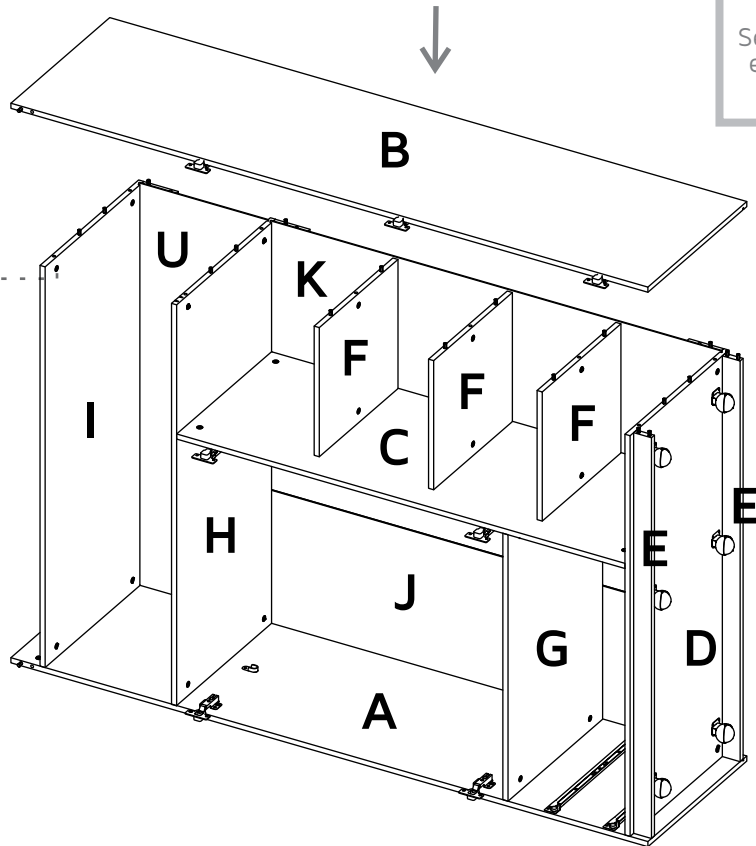
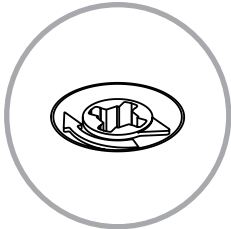

24

Door bumpers/
Tope Puertas

Rotate
Voltrear

Rotate
Voltrear

Lower slider/
Deslizador parte inferior /

Top slider/
Deslizador parte superior /

Lower slider/
Deslizador parte inferior /

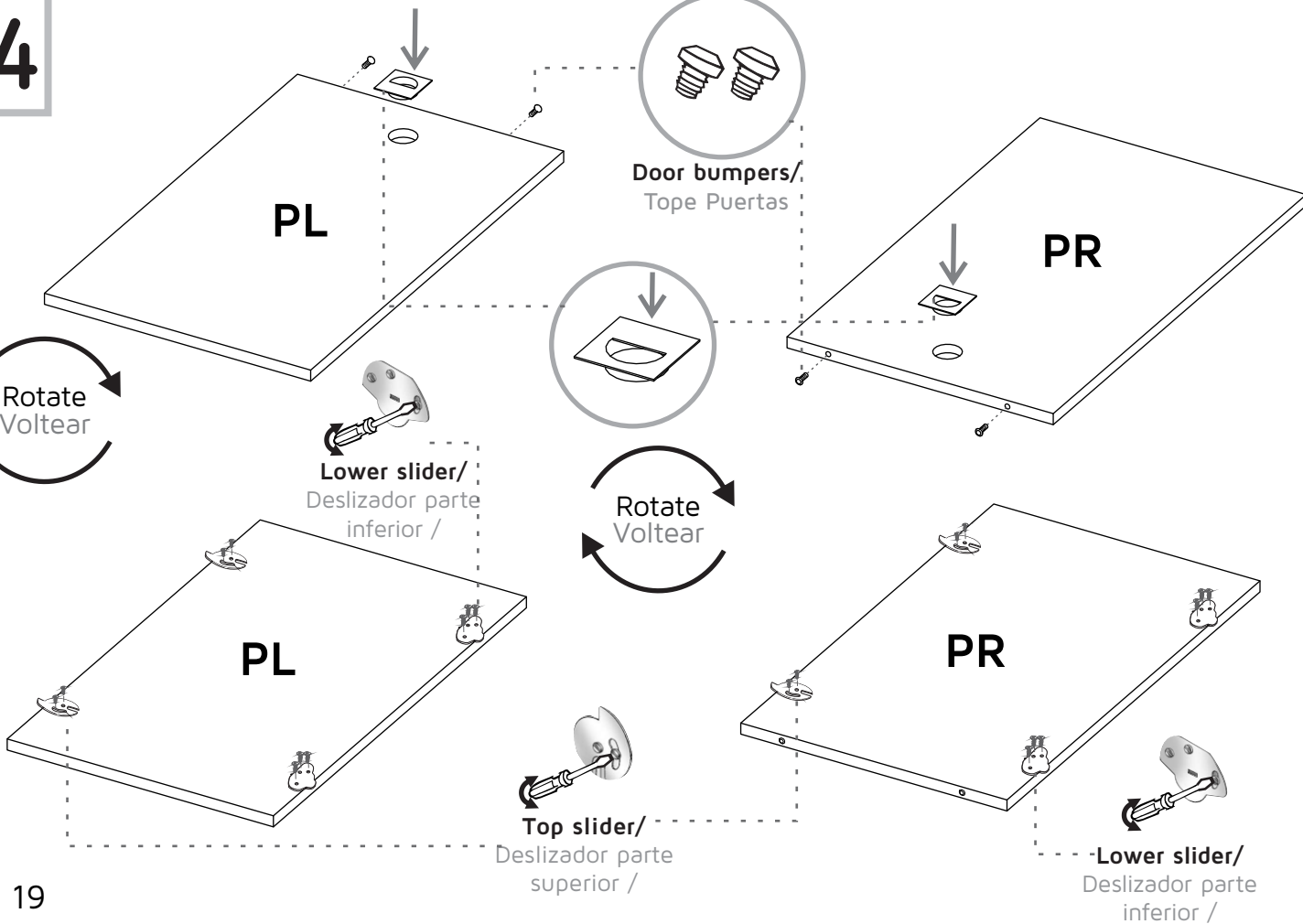

25

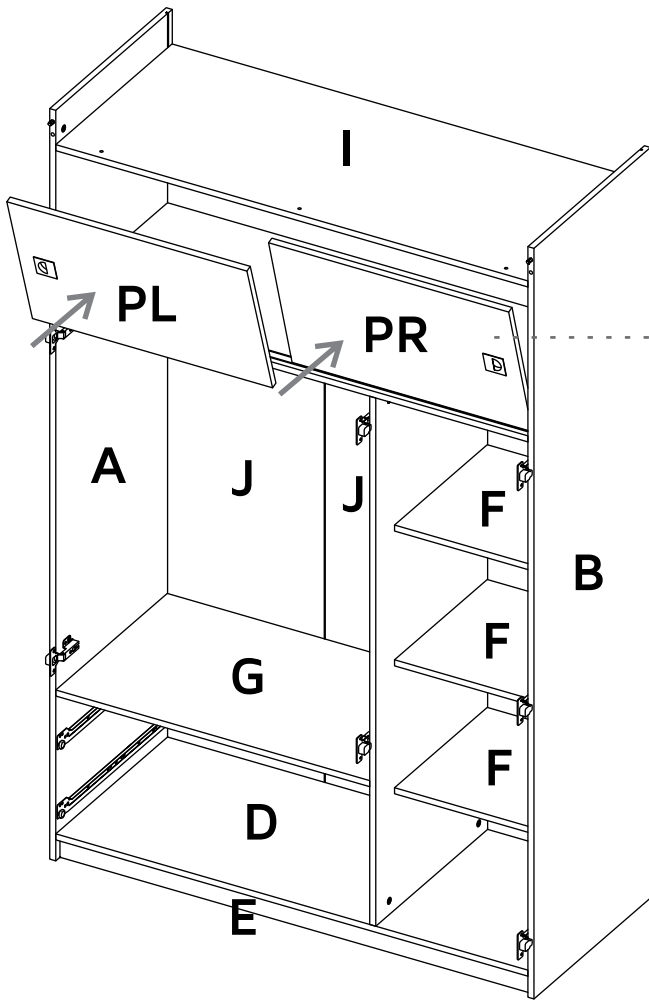

Carefully Flip
The Furniture
Voltar el mueble
cuidadosamente

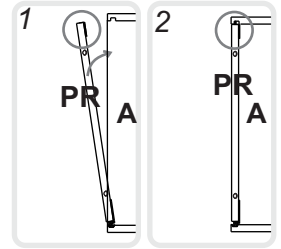

Enter the edges of the
plate in the slots, turn
and tighten the screw
Introduzca los bordes de
la placa en las ranuras,
gire y apriete el tornillo



Locate the PR door first and
then the PL door/
Ubicar primero la puerta PR
y a continuación la puerta PL

26

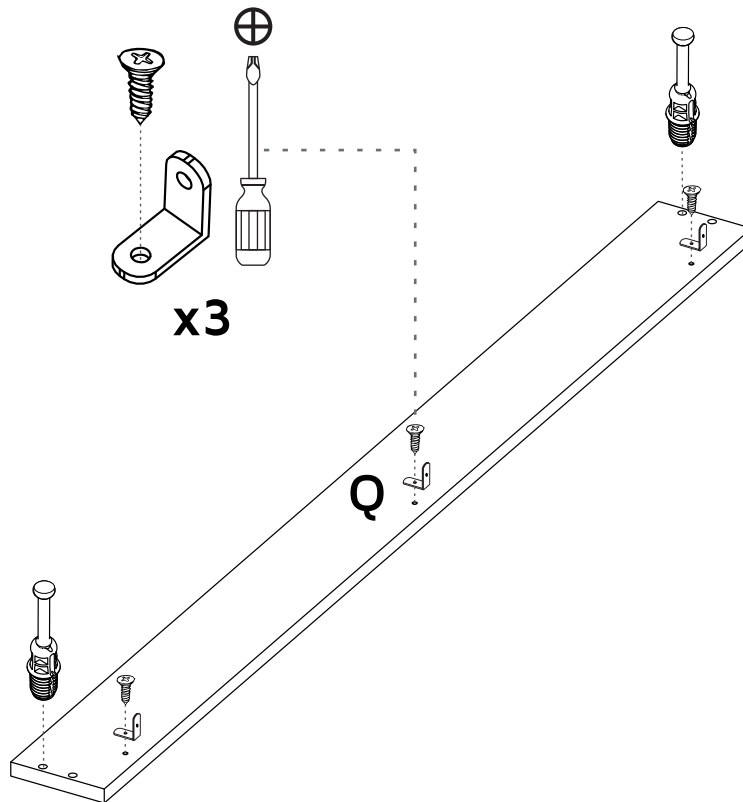

27

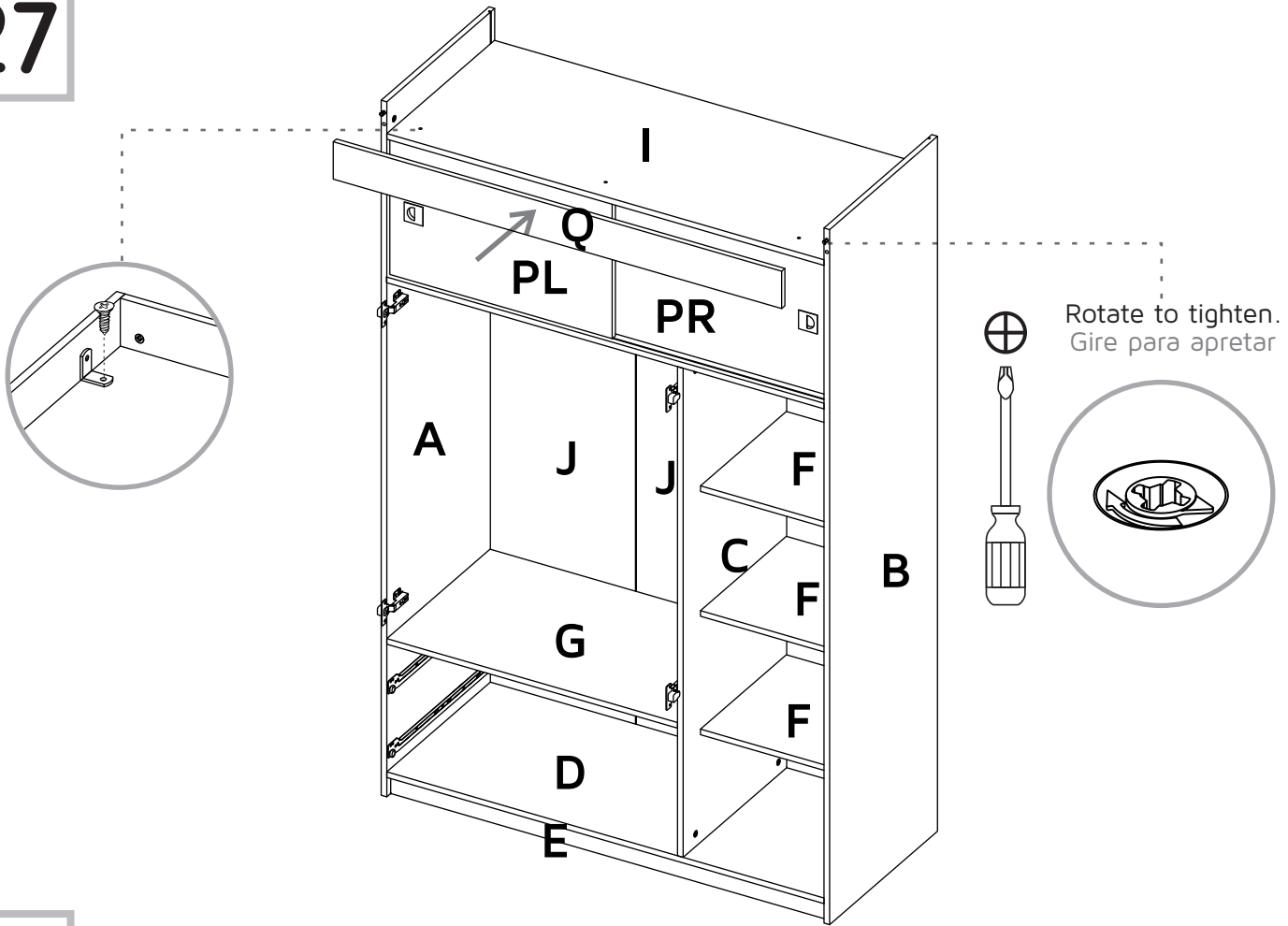

28

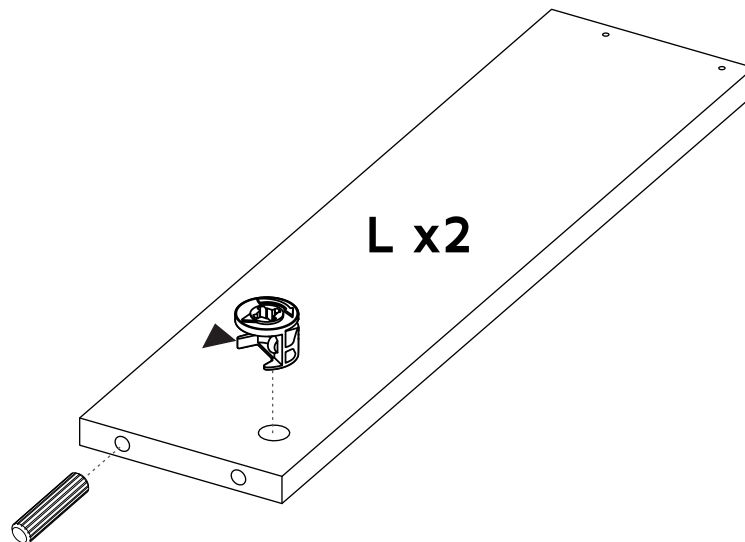

29

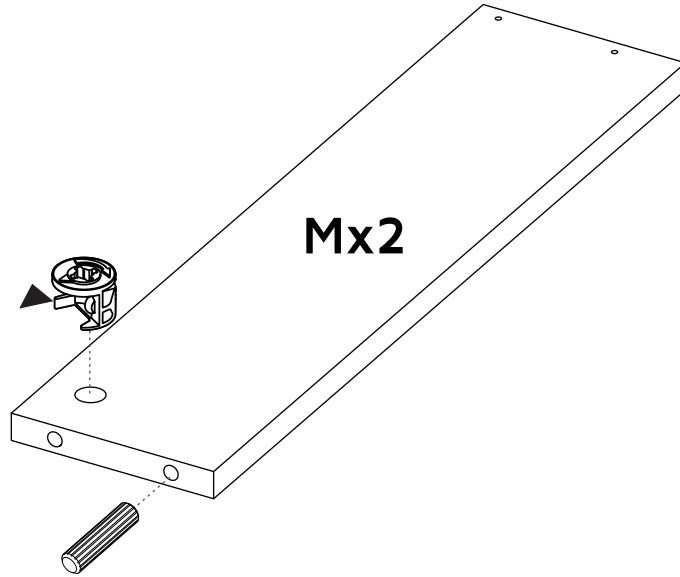

30 x2

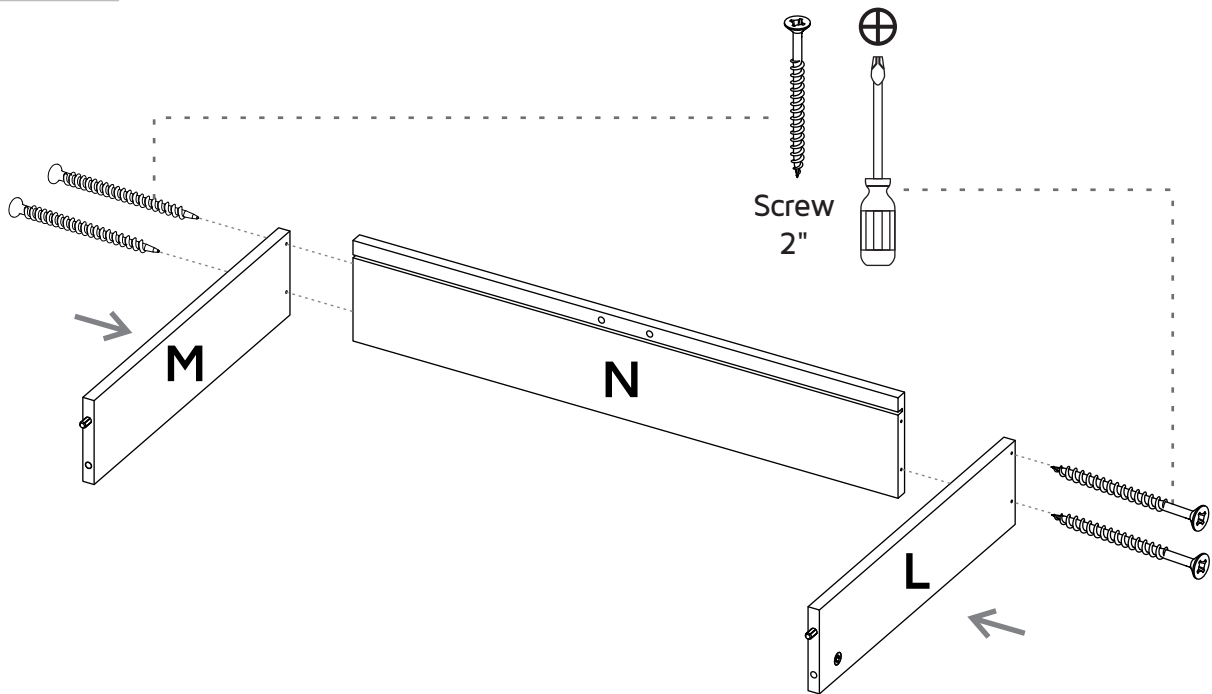

31 **x2**

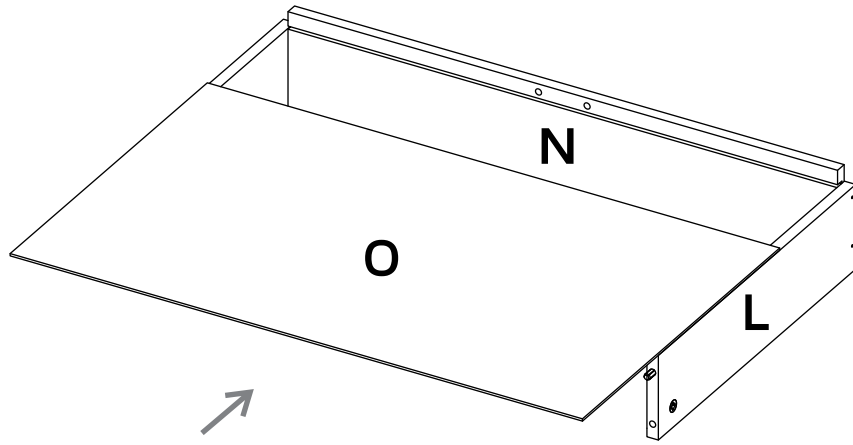

Slide Inside
Deslizar Dentro

32

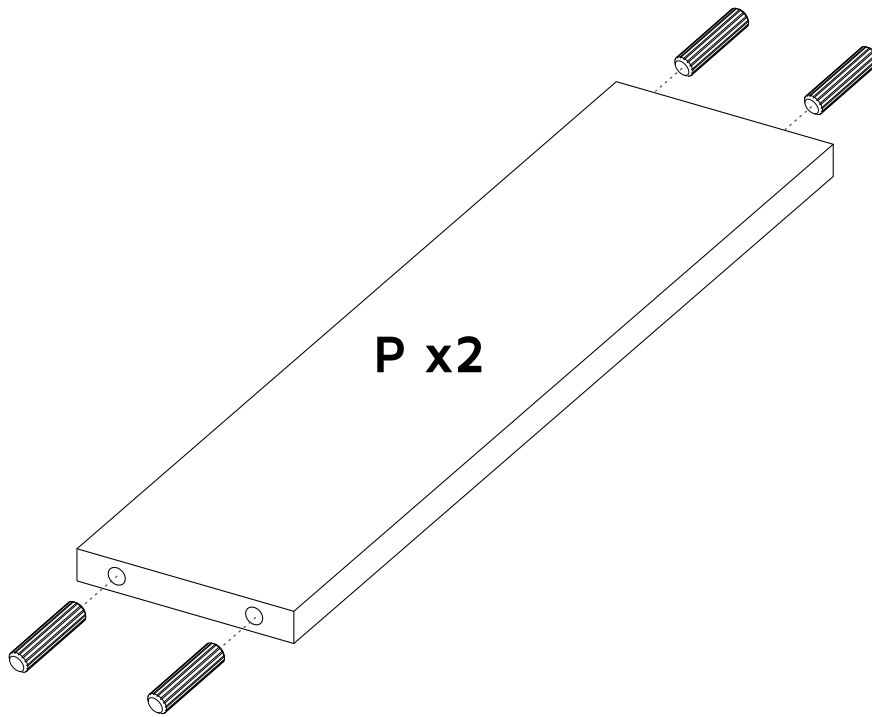

33

x2

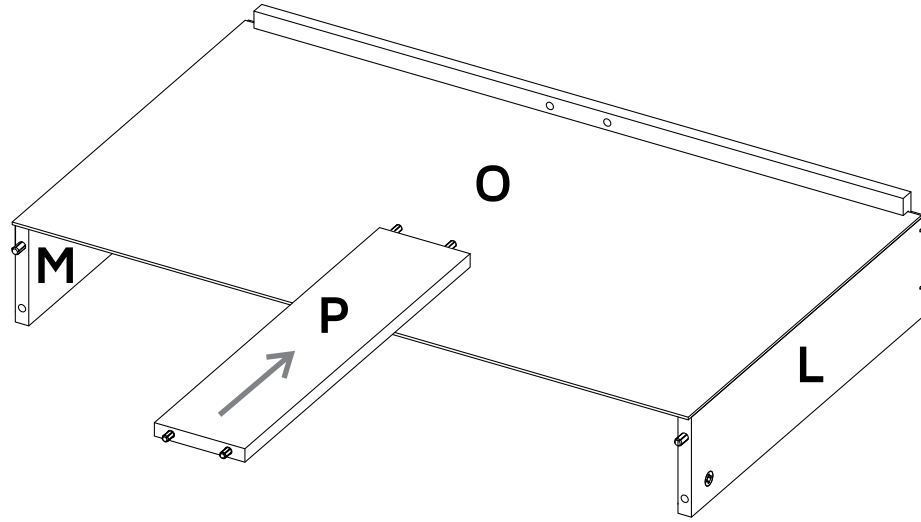

34

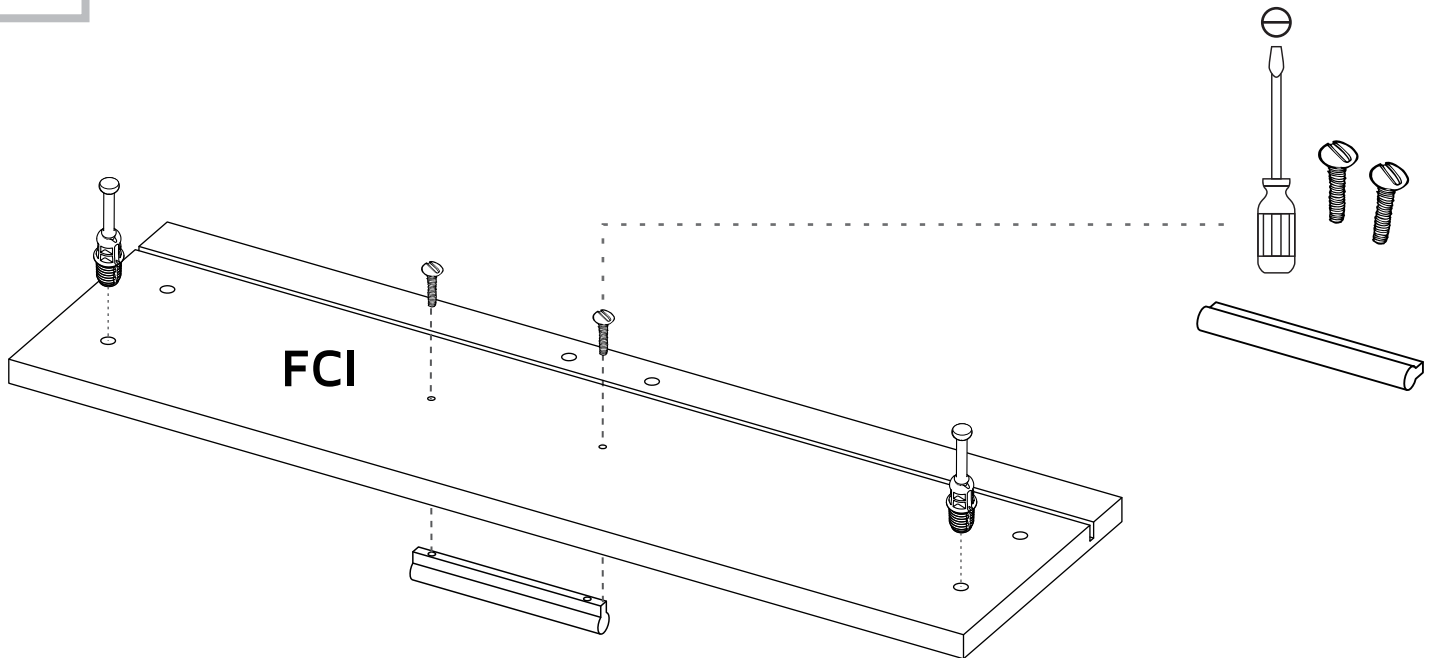

35

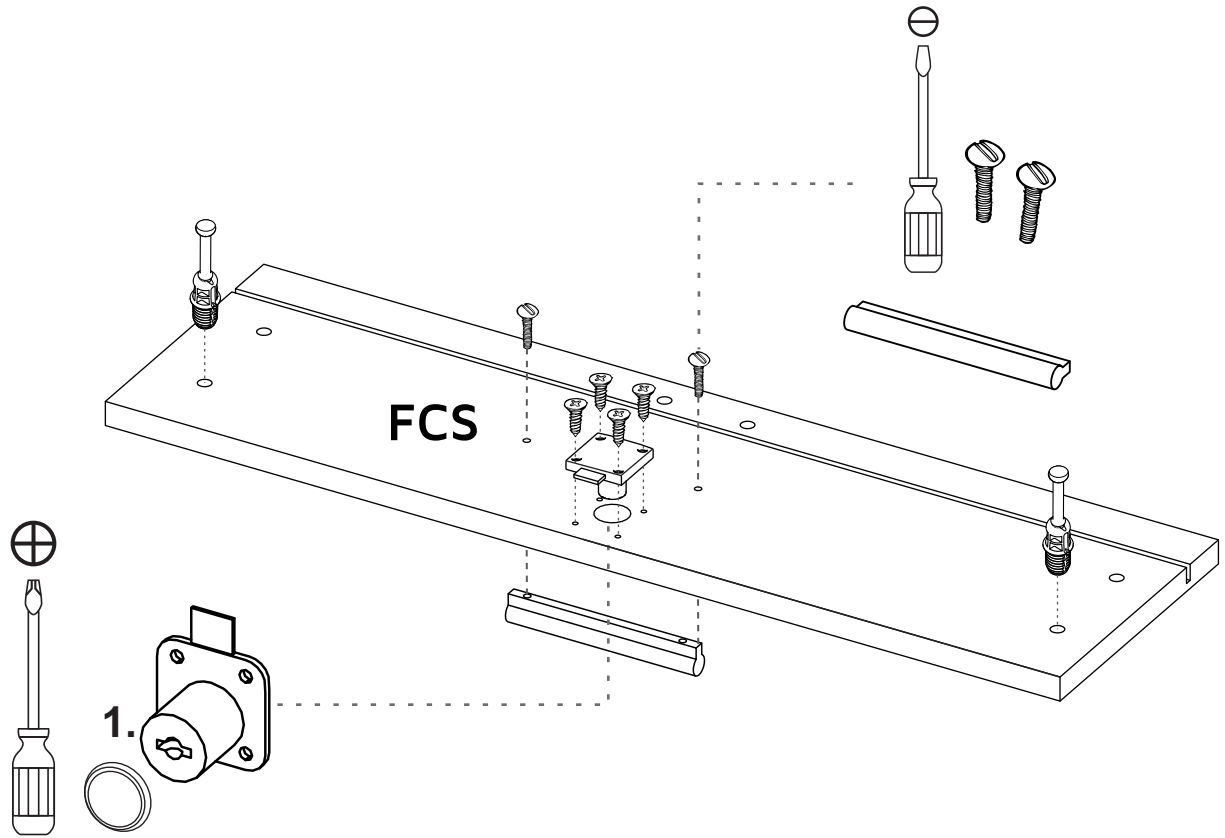

36

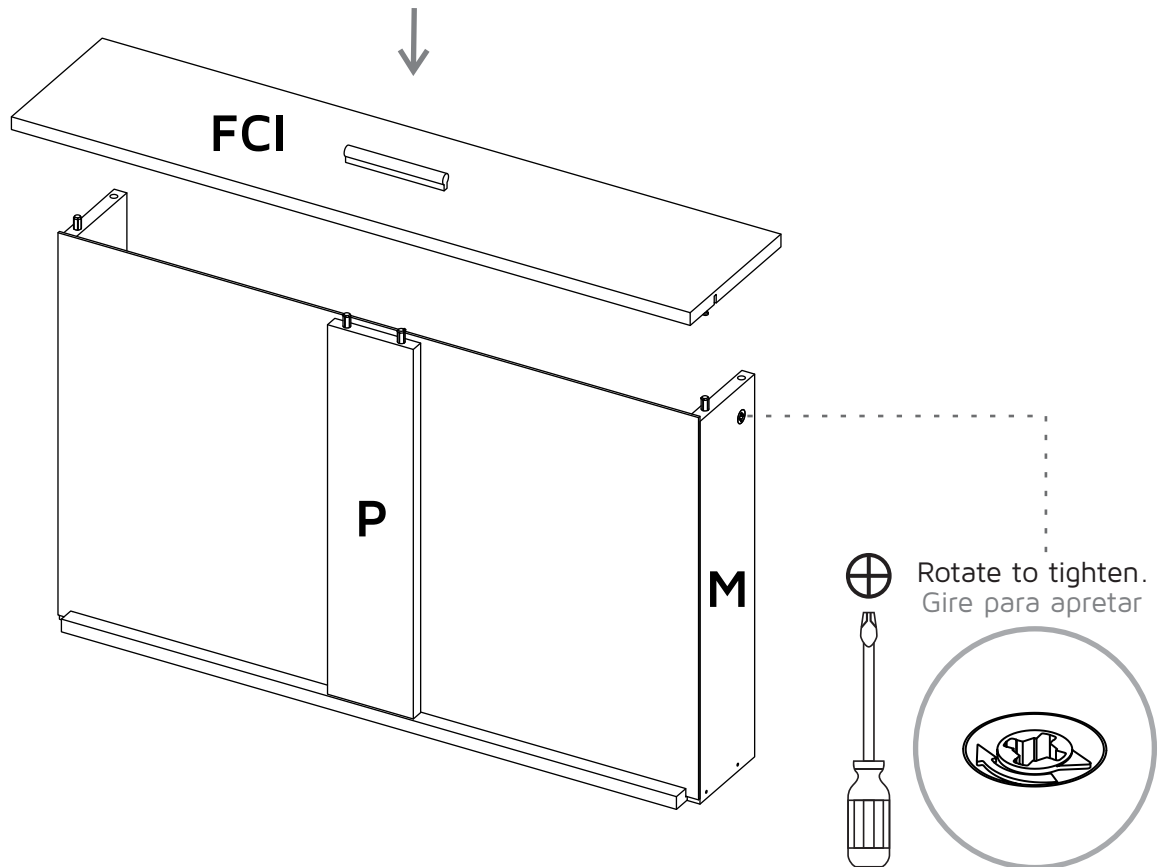

37

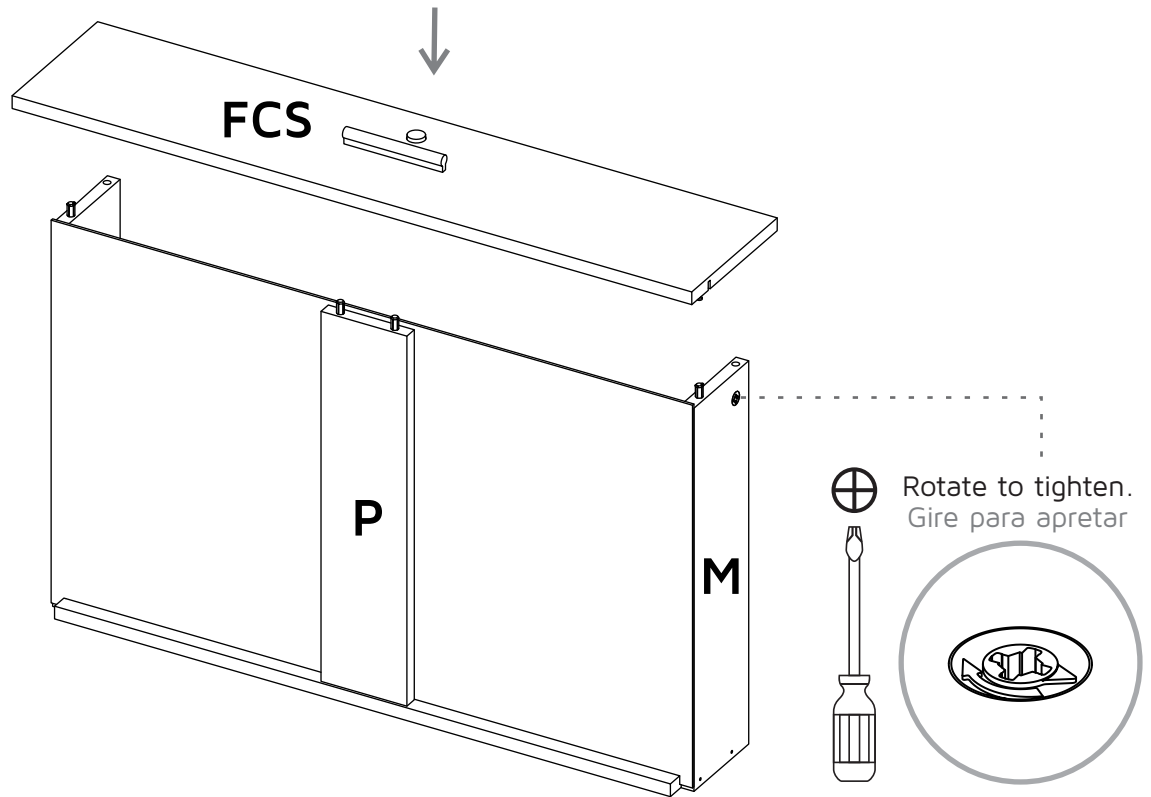

38

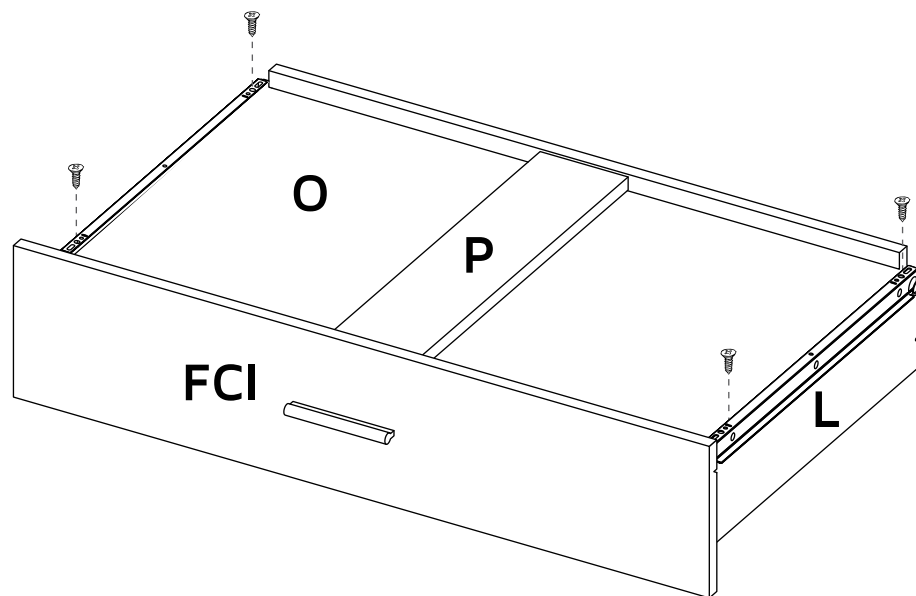

39

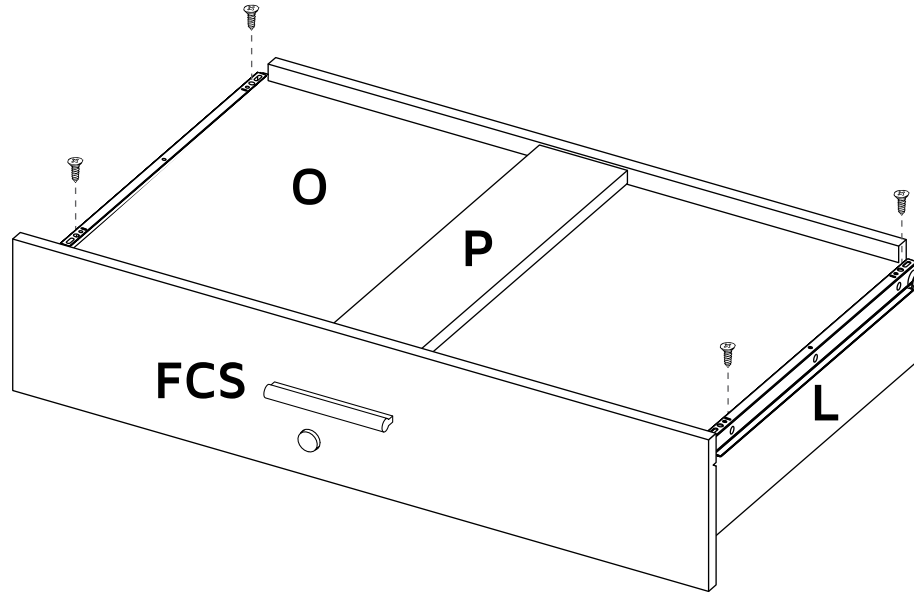

40

Carefully Flip
The Furniture
Voltear el mueble
cuidadosamente

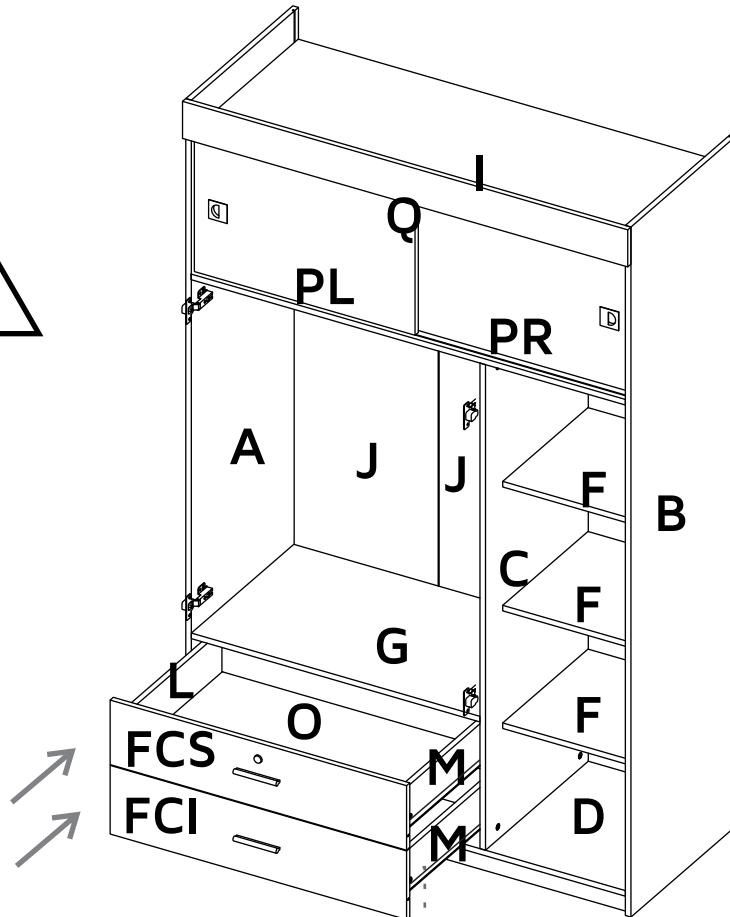

Slide the drawers
inside the cabinet.
Deslice los cajones
dentro del mueble.

41

Door Installation Instalación de las Puertas

Don't forget to
tighten the rear
minifix cams
No olvide apretar
las cajas
minifix traseras

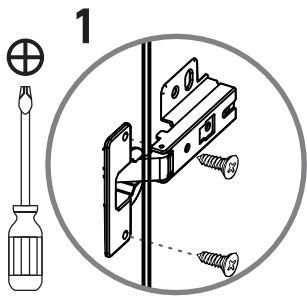
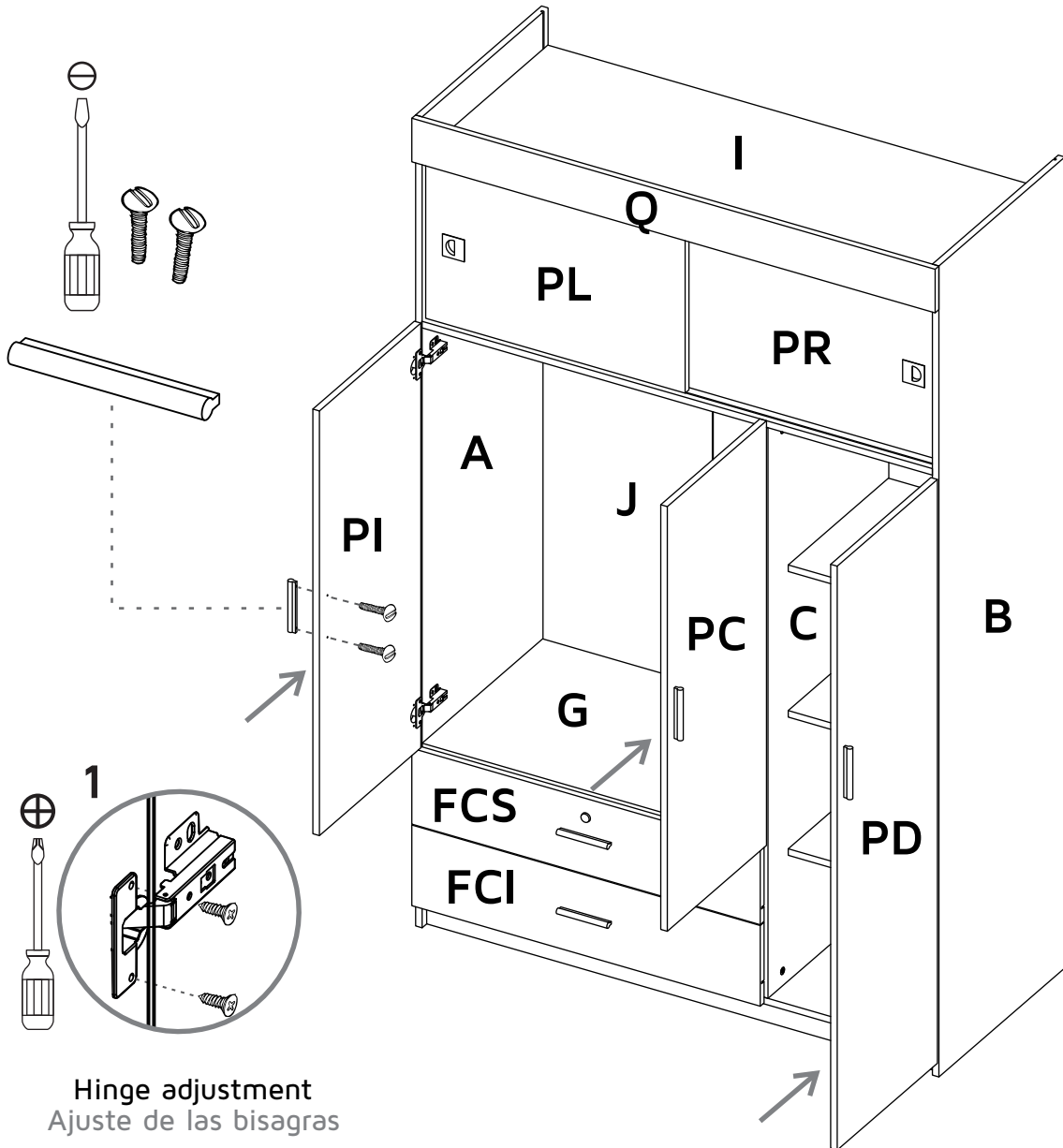

Hinge adjustment
Ajuste de las bisagras

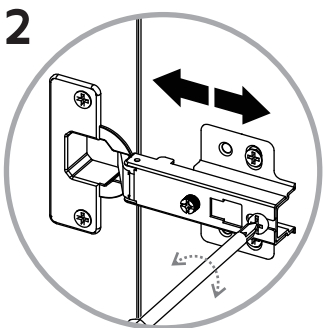

Depth adjustment
Ajuste de profundidad

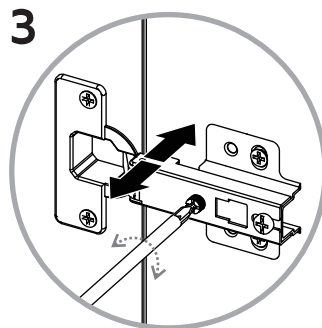

Side adjustment
Ajuste lateral

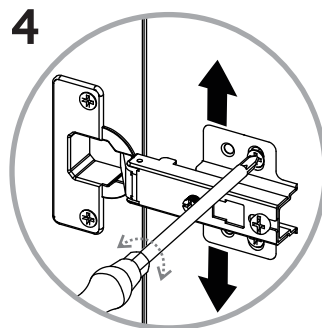

Height adjustment
Ajuste de altura

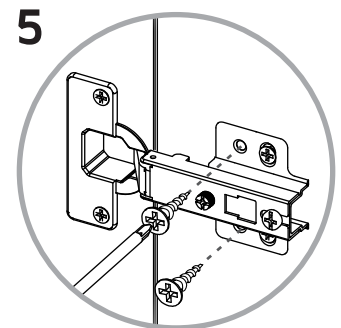

Rod Support Installation Instalación de Soporte Tubo

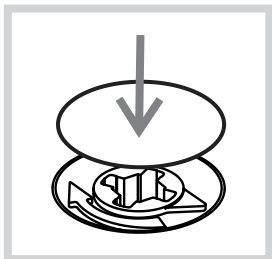
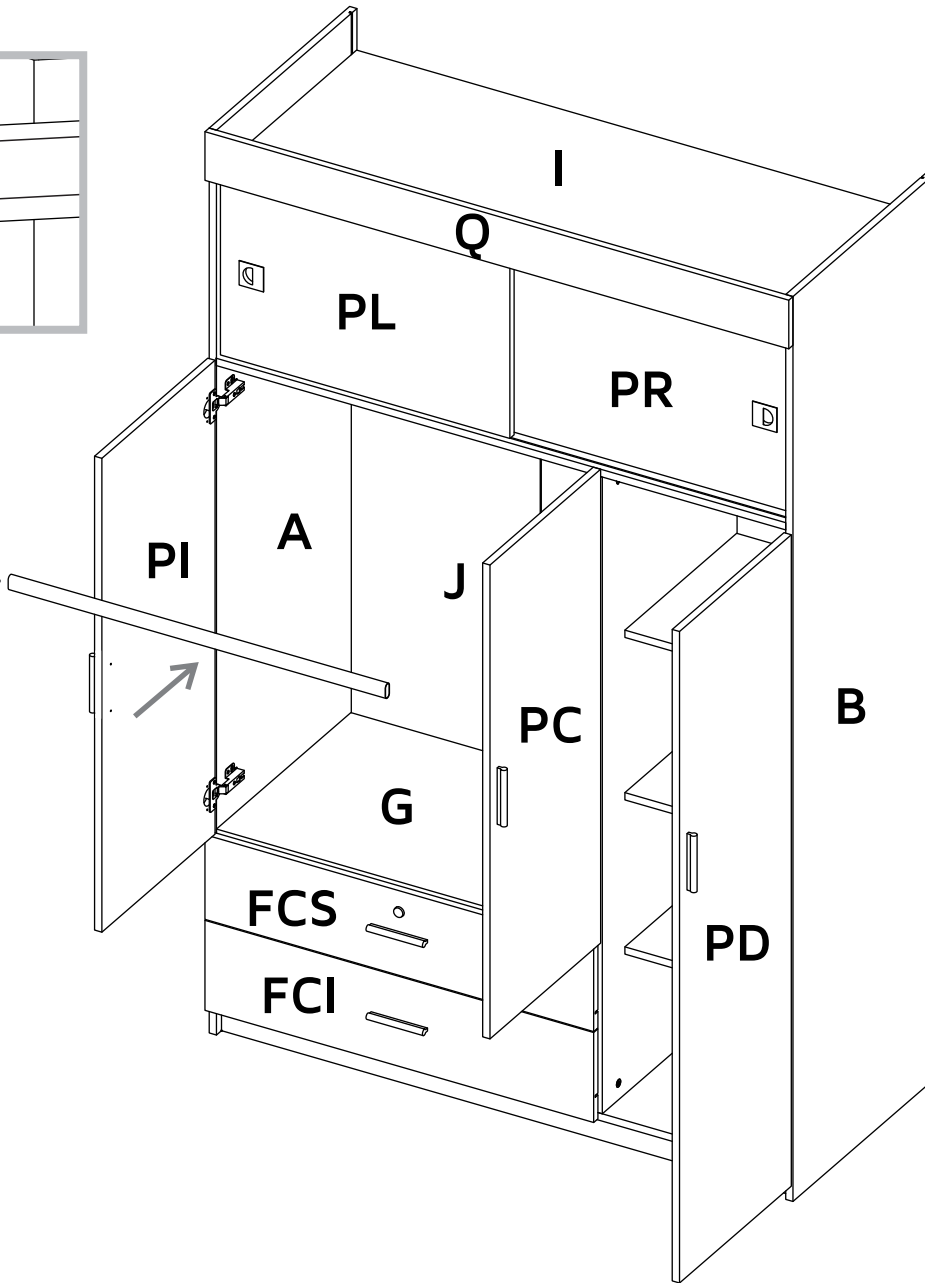
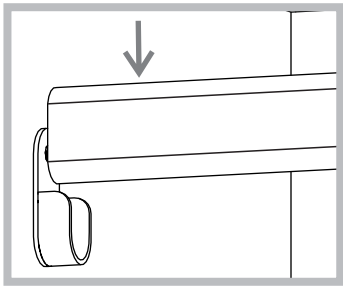

After you finish the adjustment of the cams, cover them with the cover caps.

Después de ajustar todas las cajas minifix, cúbralas con las tapas adhesivas.

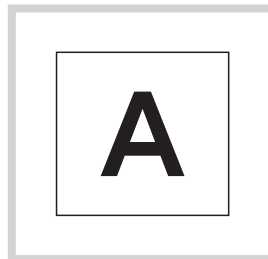

After you finish assembling the cabinet, take off the adhesive letters.

Al terminar de armar, desprenda las letras adhesivas.

WARRANTY POLICY

PÓLIZA DE GARANTÍA

Furniture has a 3 year warranty coverage in wooden parts and 1 year warranty coverage in hardware pieces since its manufacturing date, which you can see in the lot number printed on the product box and the assembly instructions leaflet.

Warranty covers materials and workmanship imperfections which impair the assembly or correct functioning of the cabinet.

This warranty is not valid if the defects or imperfections are caused by the incorrect following of the assembly instructions, warnings and recommendations, misuse, intentional damage, fire or flood, or after modifications or any kind of alteration, or repaired by someone not authorized, when it's been assembled 3 months after the date of purchase. These defects **MUST** be reported before the warranty coverage period ends. Once the product has been assembled, the company will not be responsible for defective and/or damaged parts.

This warranty is **ONLY** valid for the **ORIGINAL PURCHASER**, it doesn't apply if the product has been resold, rented, etc.

Furniture will take no liability for incidental or consequential damages caused to or by the product (This may not apply in your state).

To make this warranty valid you must write to our customer service email describing the product defect, lot number and submitting your sales receipt or proof of purchase, or contact us at our customer service line. Replaced parts will be under the product's original warranty coverage period. Damaged parts will become property of the company.

There are no other warranties applicable to this product.

**IF ANY PARTS ARE BROKEN OR
MISSING PLEASE CONTACT US**
AT: 1-888-391-01-66 /
customerservicetuhome@rta.com.co
**OUR CUSTOMER SERVICE TEAM WILL PROVIDE
YOU HELP TO RESOLVE ANY ISSUES IMMEDIATELY**