

LC 200

Modular Rear Bumper

INSTALLATION INSTRUCTIONS



Rear Bumper Parts Identification

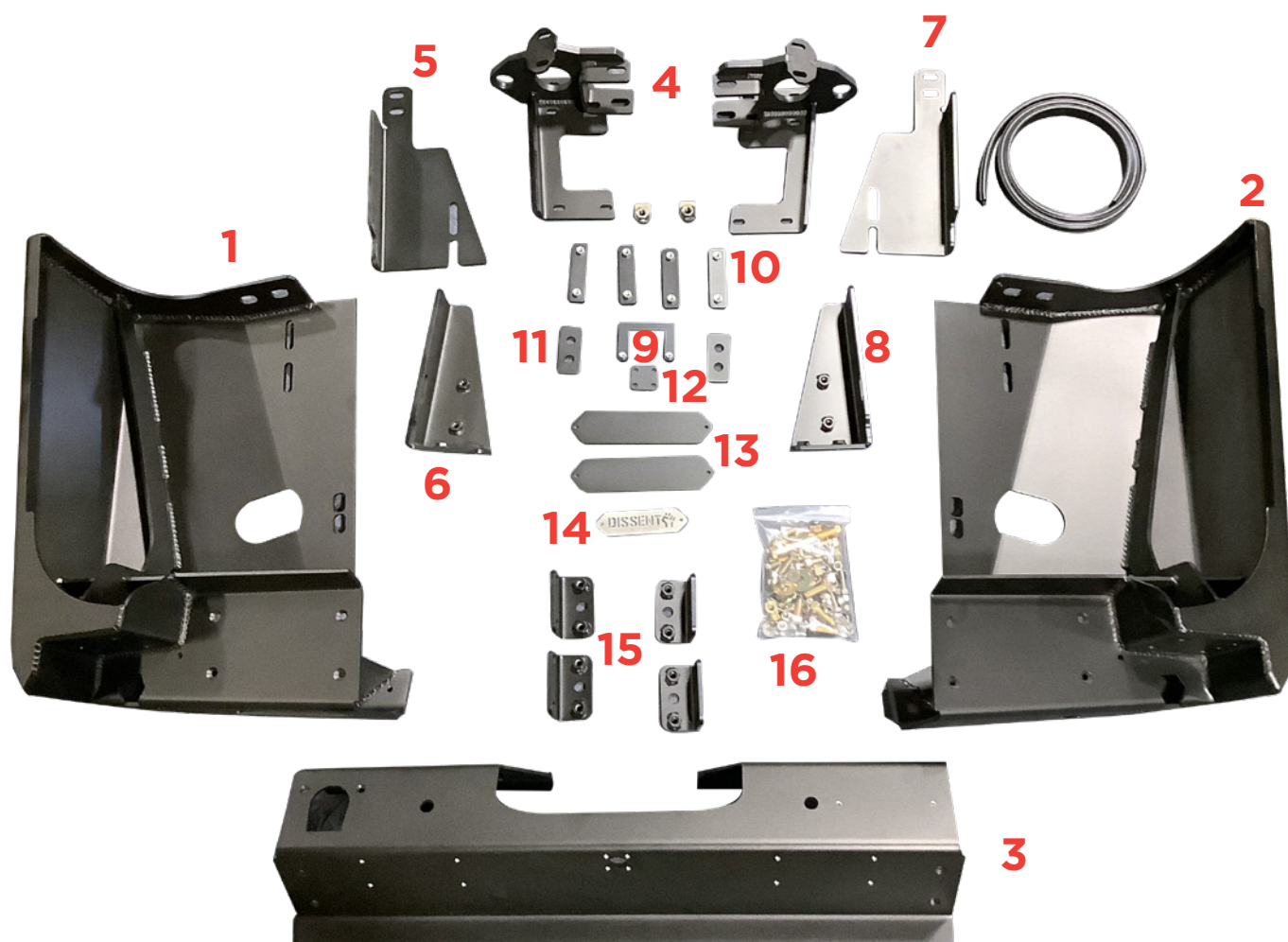

- | | |
|-------------------------------------|---|
| 01. Driver Wing | 12. Bumper blank-off (only used if NOT relocating camera) |
| 02. Passenger Wing | 13. Rear light blank-off (combo light bracket substituted if combo lights were ordered) |
| 03. Center Section | 14. Logo badge |
| 04. Recovery points (2x) | 15. Hinge bracket nut plates (4x) |
| 05. Driver lower frame stiffener | 16. Hardware kit |
| 06. Driver upper frame stiffener | |
| 07. Passenger lower frame stiffener | |
| 08. Passenger upper frame stiffener | |
| 09. Trailer plug backer | |
| 10. 5/16" PEM nut plates (4x) | |
| 11. Two-hole spacer (2x) | |

Tire Carrier Parts Identification

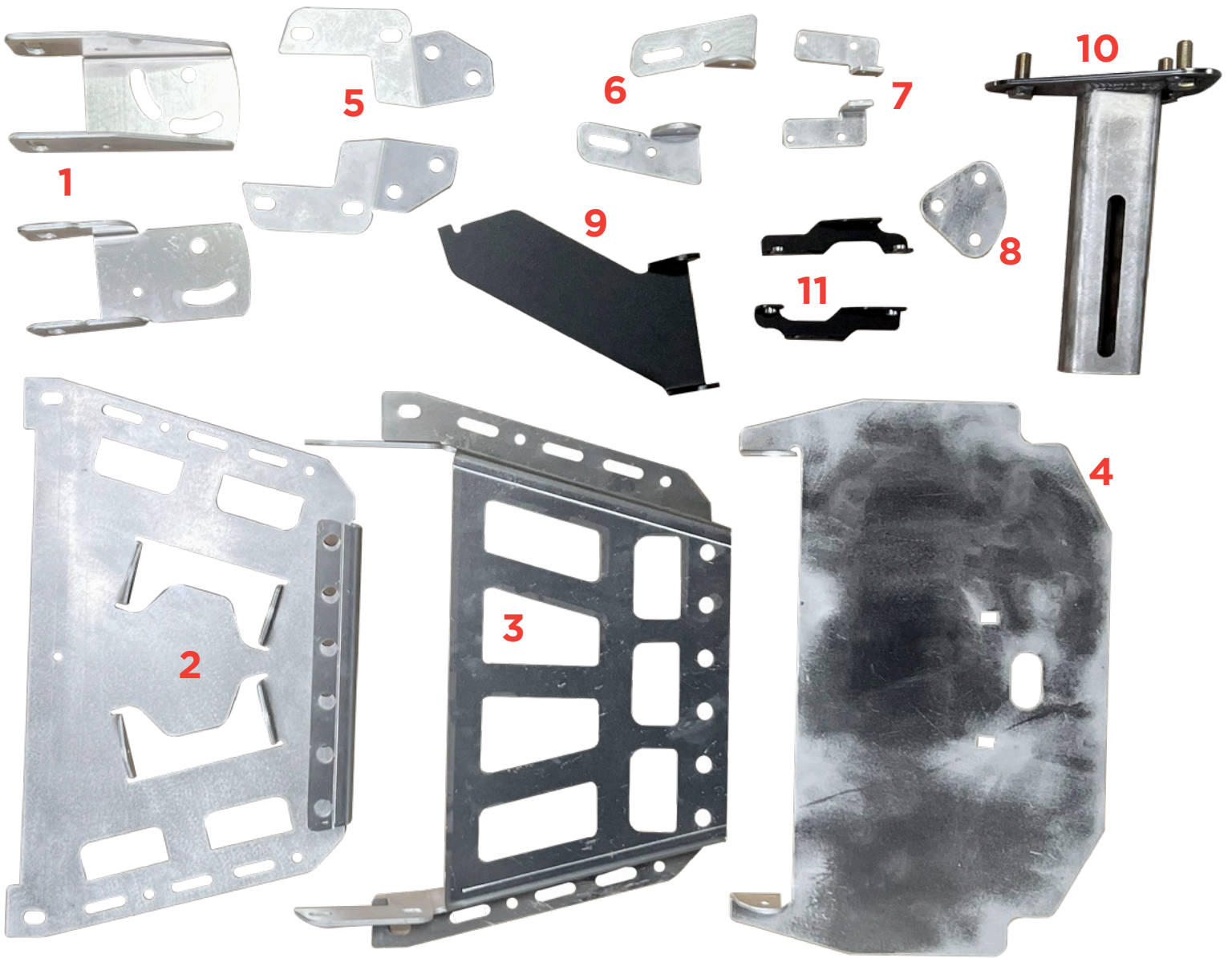

- 01. Tire clamps
- 02. Front riser
- 03. Rear riser
- 04. Table
- 05. Rear riser leg reinforcement
- 06. Table hinges

- 07. Spring tabs (one per swing arm)
- 08. Swash plate for tire clamp
- 09. Table leg
- 10. Tire mount
- 11. License plate brackets

1) Rear Preparation

Remove stock bumper components

- a) Remove mud flaps
- b) Remove bumper plate – pull up, it is snapped in
- c) Unplug wire harness on driver's side
- d) Remove bolts, screws, and clips around rear bumper cover
- e) Remove bumper cover
- f) Remove lower bumper reinforcement
- g) Remove lower side cover protectors
- h) Remove trailer hitch and bracket

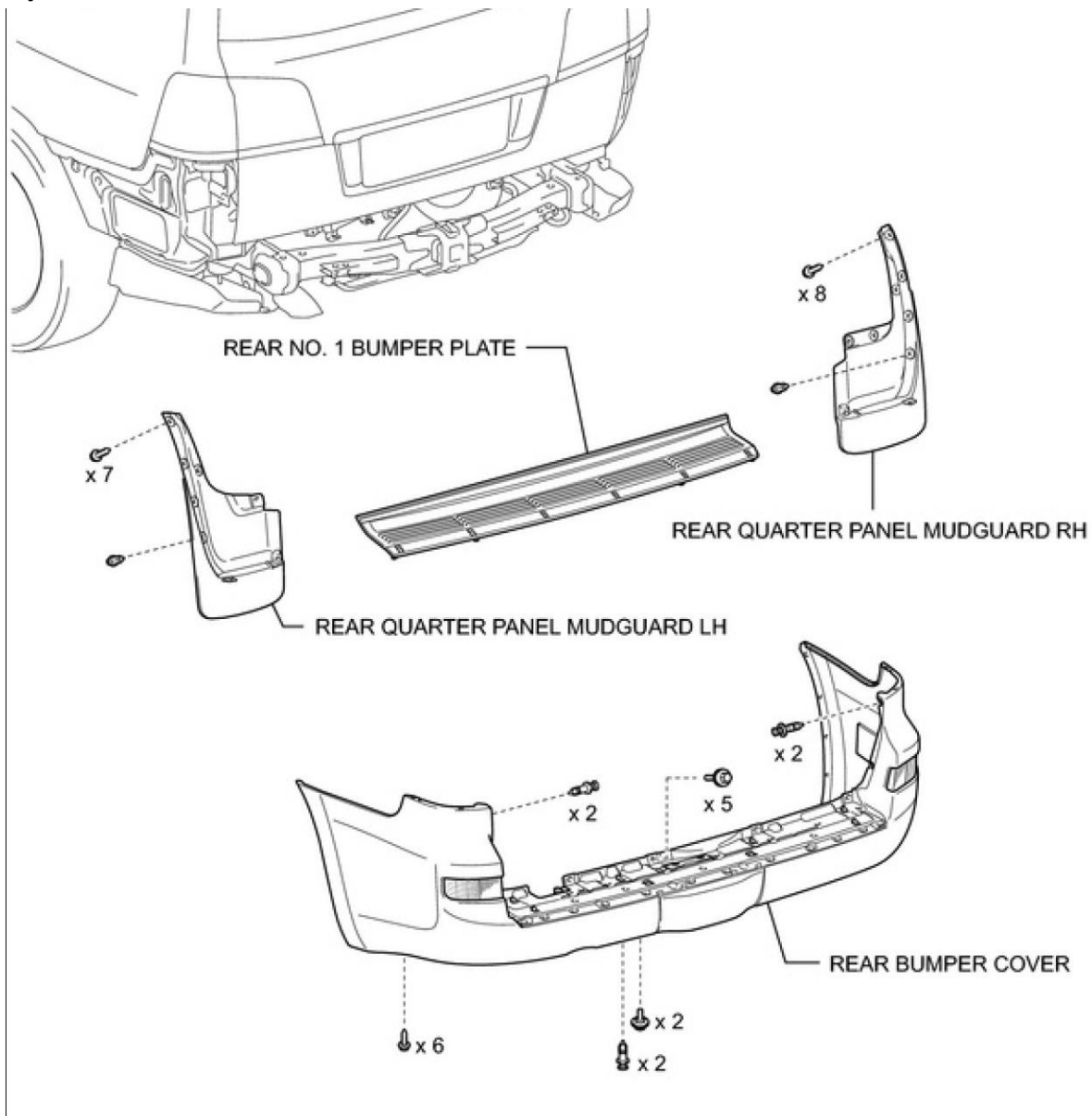

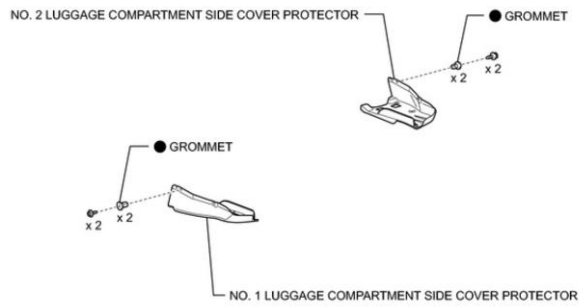
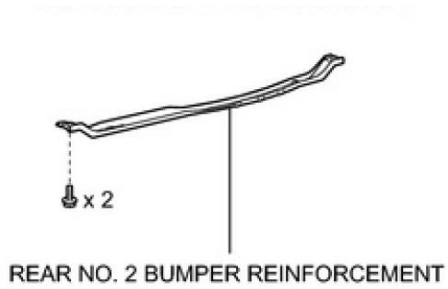

i) Trim 3 areas on driver/passenger side

- Cut a small 45 degree section off the tire side
- Cut off the 4 mounting points
- Paint cut areas for rust protection

Before:



After:



Note: Some early models (2008-2009) have additional bracing on the crossmember that needs to be trimmed (only on the Passenger side).

Measure 4.5" from the end and cut off the protruding bracket. Grind down flat and paint for rust protection.



Install Trailer Plug

a) Use shown bracket and 1/4-20 counter-sink bolts



b) Next, rear boot needs to be removed from the plug



c) Finally, route the wire underneath the cross-member through notch, as depicted



Bumper assembly

a) Slide on recovery points.

- Longer sides out towards the sides of the rig.

Driver's side:



- Insert long $\frac{1}{2}$ " bolt from bottom of recovery point and attach captive nut/bolt from the top. Finger tighten to allow movement in recovery point:

Note: use anti-seize on all captive nuts



b) Install center section between the recovery points:

- Use 4 stainless steel screws and two double nut plates. Leave loose for final adjustments.



- Double nut plates will be used on the 8 holes around the recovery points (green below). The remaining screws will be secured with washers and nuts.

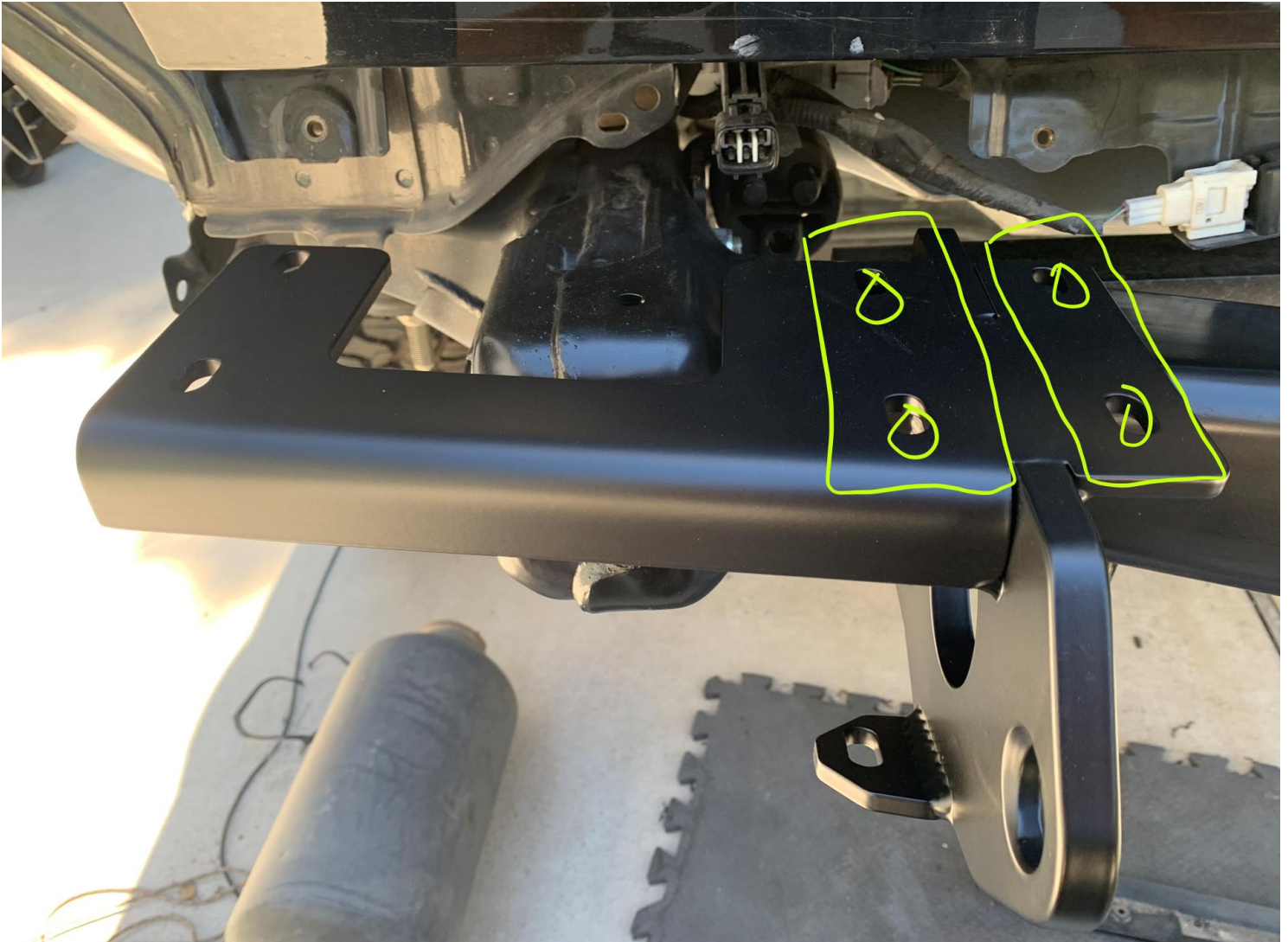

c) Prepare driver side wing

- **These are the parts you will need:**



- **And this is how they will stack up onto the frame (red line represents the frame):**



- Remove this plug to allow bolt pass-through



- Lift the 2 steel wing stiffeners into place and slide long ½" bolt from the driver's side of the frame.



- The plates will hang down like this until you lift the wing into place:



- **Important: this step must be completed prior to installing the wing.**
 - i) Install two steel brackets behind the swingarm holes using $\frac{1}{2}$ " bolts.
 - ii) Use $\frac{7}{16}$ " bolts/washers to temporarily hold the brackets while you torque the $\frac{1}{2}$ " bolts from behind.
 - iii) Use the 5th hole to help align plates



iv) $\frac{1}{2}$ " bolts should be torqued to 100 ft-lbs. Wing is ready to be mounted.



d) Install Driver side wing:

- Lift wing into place and secure with rectangle washer, two 10.9 bolts, and double oversized washers (red circle)
- Install additional 7/16" bolts and double oversized zinc washers (green circles)





- LC200 Repeat for the passenger side

e) LX570 Only - Passenger side Wing:

- Using a 10mm open end wrench, completely remove 3 nuts securing AHC pump to its bracket (green circle). You'll need to use the slot on the frame side for the 3rd nut.
- Use a flathead screwdriver to pop off a plastic wire clip that is attached to the forward side of the AHC bracket. (do not disconnect any wires, just remove the wire clip so it won't keep the bracket from coming down)

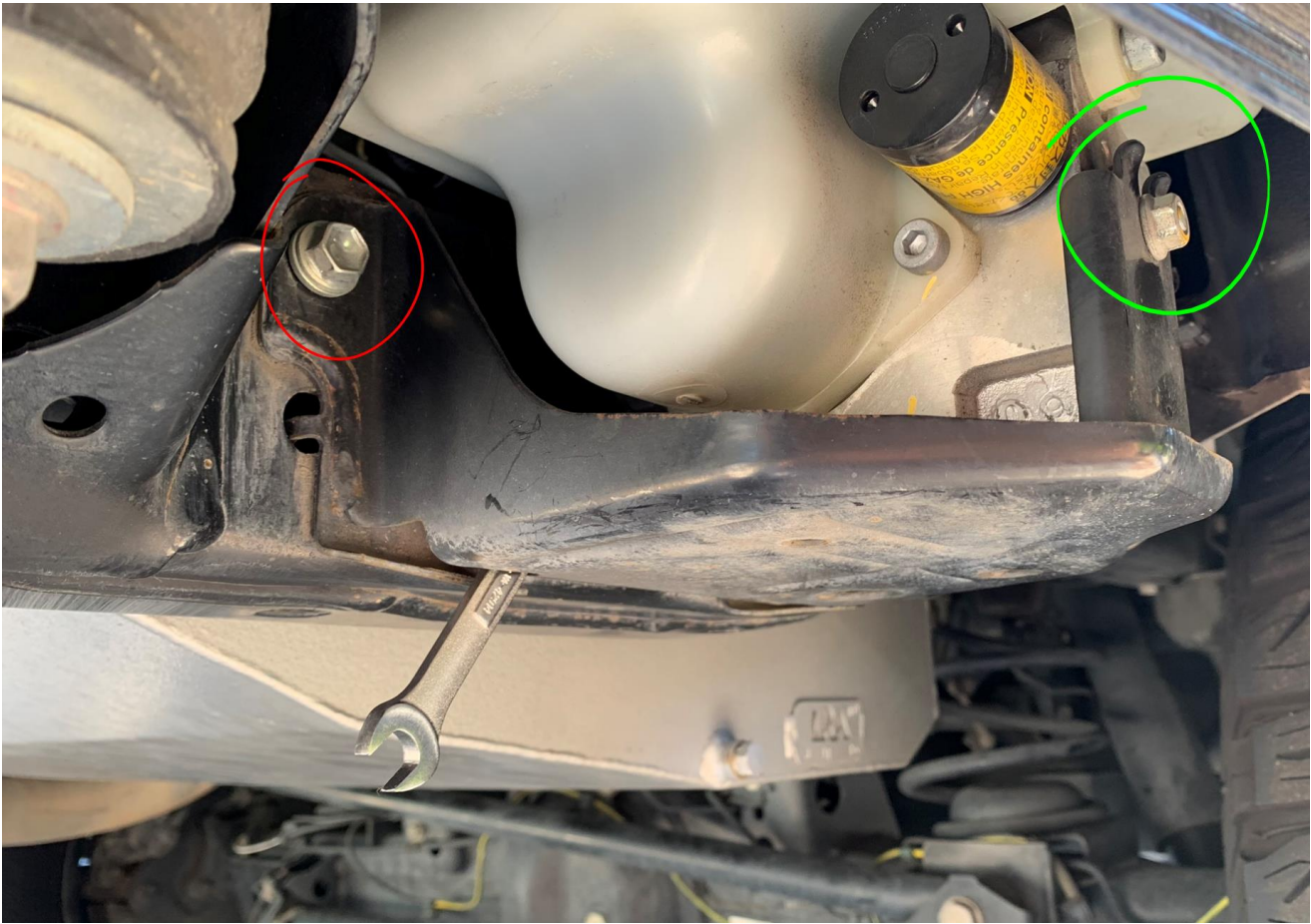

- Loosen 3 12mm bracket bolts from frame (red circle above). The forward side of the bracket has two 12mm bolts, you can completely remove the lower one.
- While holding the entire pump assembly in place, remove the remaining 12mm bolts, slide out the stock bracket, slide in the new bracket, replace 12mm bolts to frame, and replace three 10mm nuts to pump assembly.
- The 3 pump studs have rubber grommets on the back side, make sure these stay in place – you should have rubber grommet → a/c bracket → 10mm nut.
- 10mm nuts get torqued to 49in-lbs (or until rubber grommet starts to move)
- 12mm frame bolts get torqued to 23ft-lbs



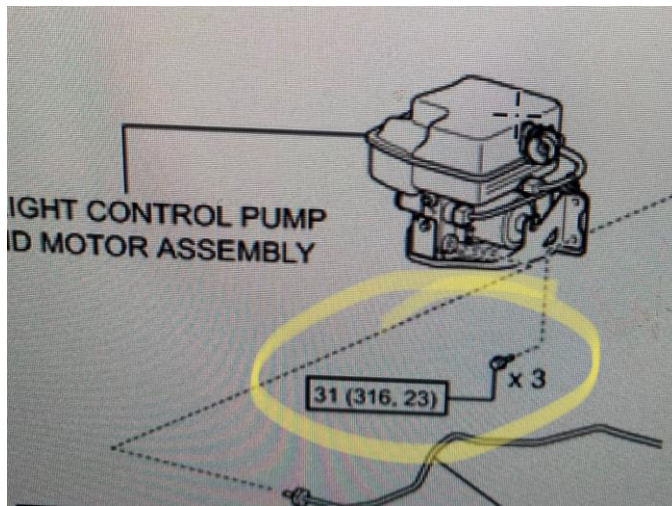

- The passenger side wing stiffener is flat and does not have a through bolt to the frame. Unlike the driver's side, place the stiffener onto the wing and loosely attach with two 7/16" bolts and double oversized zinc washers (yellow arrows below)



- Trim the bottom portion of the plastic wheel well liner off to avoid contact with the wing (below the AHC access panel). You may also choose to disconnect all the plastic clips and push the entire liner

forward towards the wheel. Once the wing is in place, you can trim and tuck this back in.



- Lift wing into place and secure with two metric 10.9 bolts into the stock tow point holes. Use double oversized zinc washers and a rectangular Dissent washer (red circle below). Attach two 7/16" bolts into the AHC bracket using double oversized zinc washers (green).

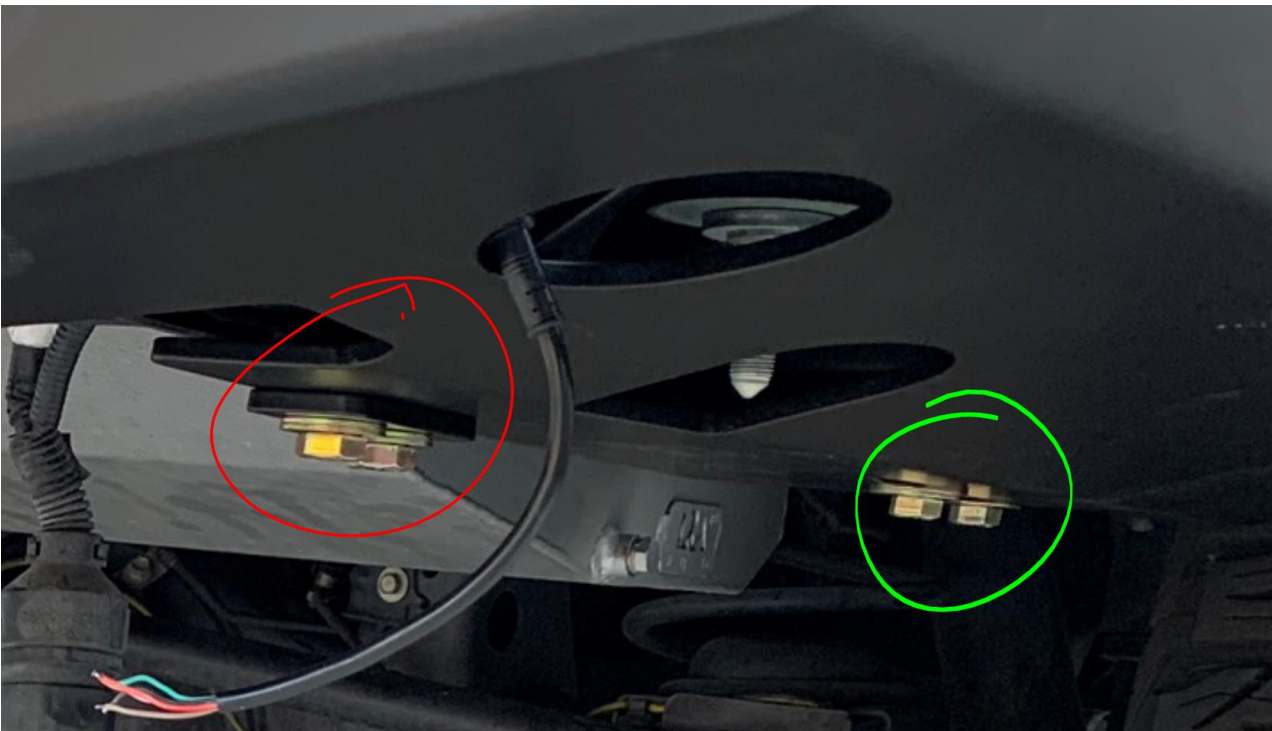

- Leave all bolts slightly loose for final adjustment.

f) Final alignment:

- Install all the remaining flat stainless-steel screws into the center/wings. There are 12 on top and 4 on bottom.
- Begin with checking the position of the center section around the hitch (blue circles in section D above).
- Check the ends of the wings at the fenders. Align these so they are the same on each side.
- Snug the two 7/16" bolts on the bottom of the center section to hold this position.
- Next, check and align the joints above each recovery point. Tighten the long 1/2" bolt on the bottom of the recovery points to lock them in.
- Tighten two metric 10.9 and four 7/16" bolts on each wing.
- The tops of the wings should be in the same plane as the top of the center section. This is imperative if you're installing swing arms.

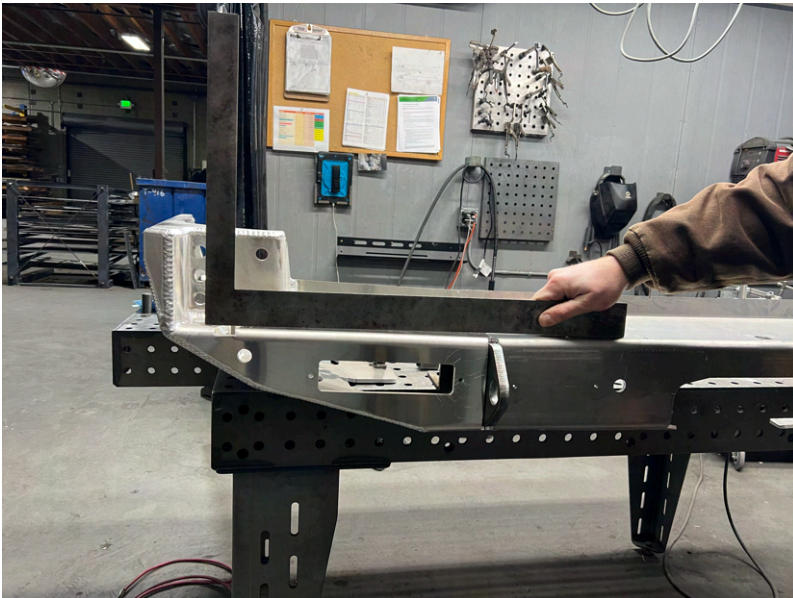

- g) Trim plastic fenders to size 5/8" recommended gap to accommodate 1/2" bulb trim and 1/8" air gap, measuring from top of wing to quarter panel and lights**



- On the tailgate side of the trim, do not cut the lower clip hole

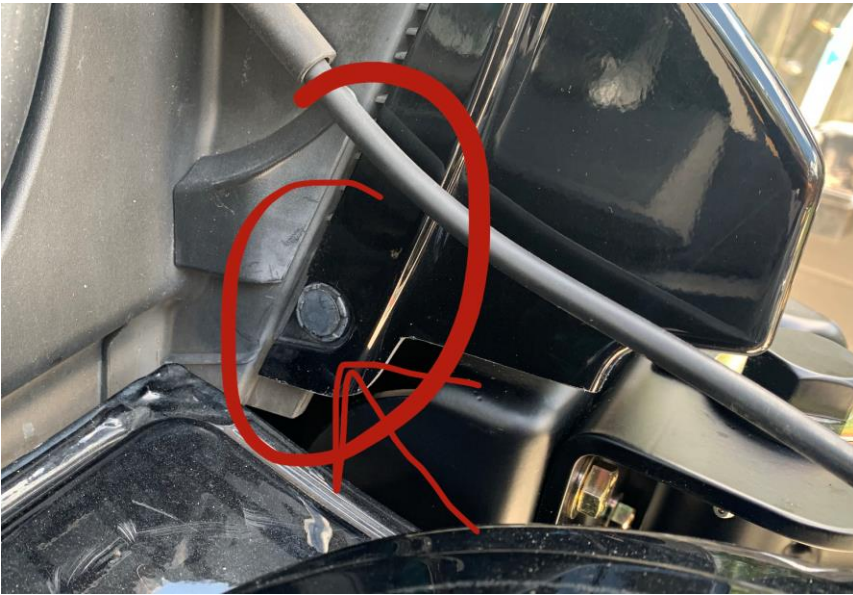

h) Parking Sensors

- Parking sensor size varies between the years/models.
- Cut the hole to be about 1/16" larger than the diameter of the sensor. Step bit is a good tool to use for this.
- Trim the plastic clips off the sensor so it fits into the rubber grommet.



- Insert grommet into hole first, then insert sensor



i) RoadVision Combo Lights

- These are the stock wire colors:

White = ground

Blue = brake

Yellow = reverse

Green = taillights (Running lights)

- These are the RoadVision wires

White - Ground

Black - Reverse

Red - Brake

Brown - Tail/ Running

Yellow (left) green (right) – Turn

- You have 2 options

- tap all the wires from the trailer harness and then use a 2 to 3 wire converter: Curt 56196



- tap the ground, reverse, and tail lights from the trailer harness, but then tap the brake and turn signals from the stock combo lights

j) Swing Arm assembly

- Pre pack bearings with marine grease or your grease of choice



- Place bearing into swingarm, then use rubber mallet to install seal



- Place bearing spacer into seal



- **Note: Newer hinge brackets may not have the screw and washer pictured below. Only use the Zinc washer.**



- **Place swingarm into hinge bracket and install swingarm bolt with large zinc washer on top and nut on the bottom (no washers on bottom) and finger tighten. Also, cover the bolt shaft with grease prior to installing.**



- **Install two (2) grease zerks fittings**
- **install the nylon liners into the handle**



- install the 5/16 stainless bolt from the bottom of the swing arm up with nylon washers on top and bottom (nut will be on top). Use anti seize on threads!

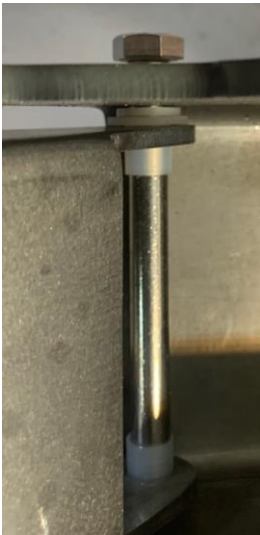

- Make sure the latch is straight and then tighten the bolt until there is no slip in the latch but it still moves freely.
- install the striker. There are extra washers included as alignment shims if needed but a good start is 2 washers (red arrow).

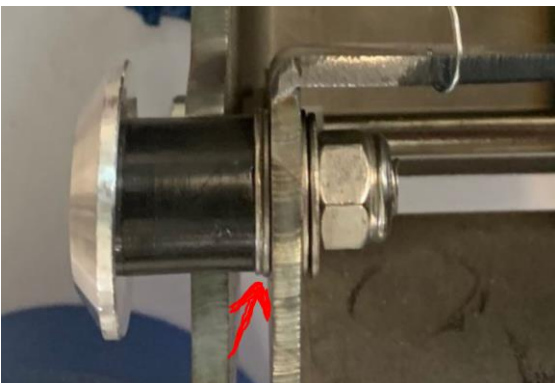

- Install the UHMW (ultra high molecular weight) pad and spring bracket. Insert flat screws into the counter sunk holes in the uhmw and place spring bracket in place. Secure with stainless steel nylocks. Install spring from bracket to latch handle.

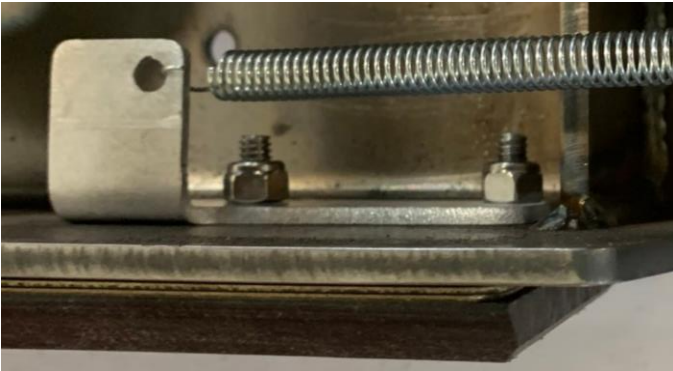

- Install uncoated Stainless Steel Striker pads with 1/4"-20 x 3/8" stainless steel button head screws



k) Swing Arm Installation

- Set swing arm into place and let it latch closed onto the striker pad



- Install and tighten the 2 outer 7/16 bolts with the swing arm closed

- Tighten the main hinge bolt. Using a towel to protect the powder/paint finish, tighten the bolt until you feel resistance on the bearings.
- Open the swing arm, install and tighten the inner 7/16 bolts.
- Now check everything is aligned and working properly. If the main hinge bolt moves the slotted washer, you need to make it tighter. Add or remove shims to the striker as needed. (Note that you will want the aluminum washer on the striker to set in between the bumper and striker pad like in the photo above)
- Use the grease zerks to grease the bearings if you didn't pre pack them.
- Install the gas strut: Carefully open the swing arm all the way and don't let it slap against the wing since there are no bump stops yet. Black body of the strut attaches to the wing, and use the second hole (furthest away from the hinge) for the strut head. Push straight down to lock onto the ball heads.



- Install bump stops: 1" bump stops (with the washers) on the inside of the swing arm and the smaller bump stop on the outside.
- The inside bump stop sets a preload on the latch. Make sure there is a proper preload on the latch to prevent rattling while driving. Add or remove washers as needed.

I) Tire Carrier Assembly



m) install the table leg to the back plate as pictured.

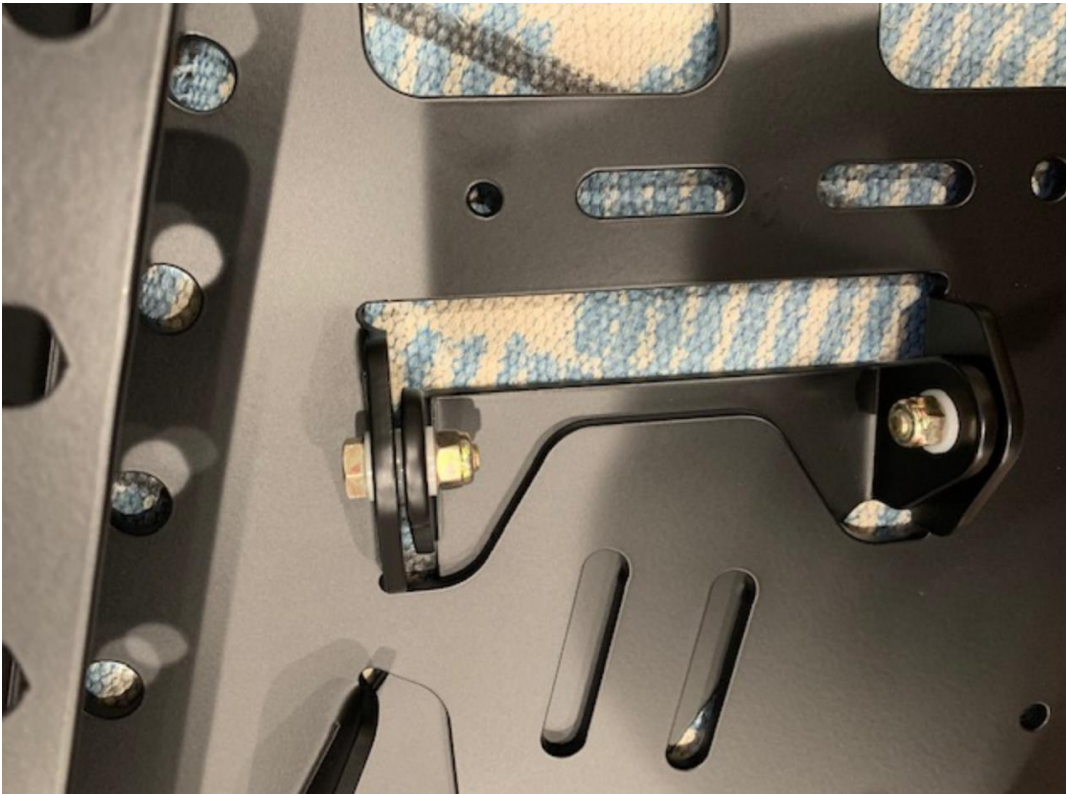
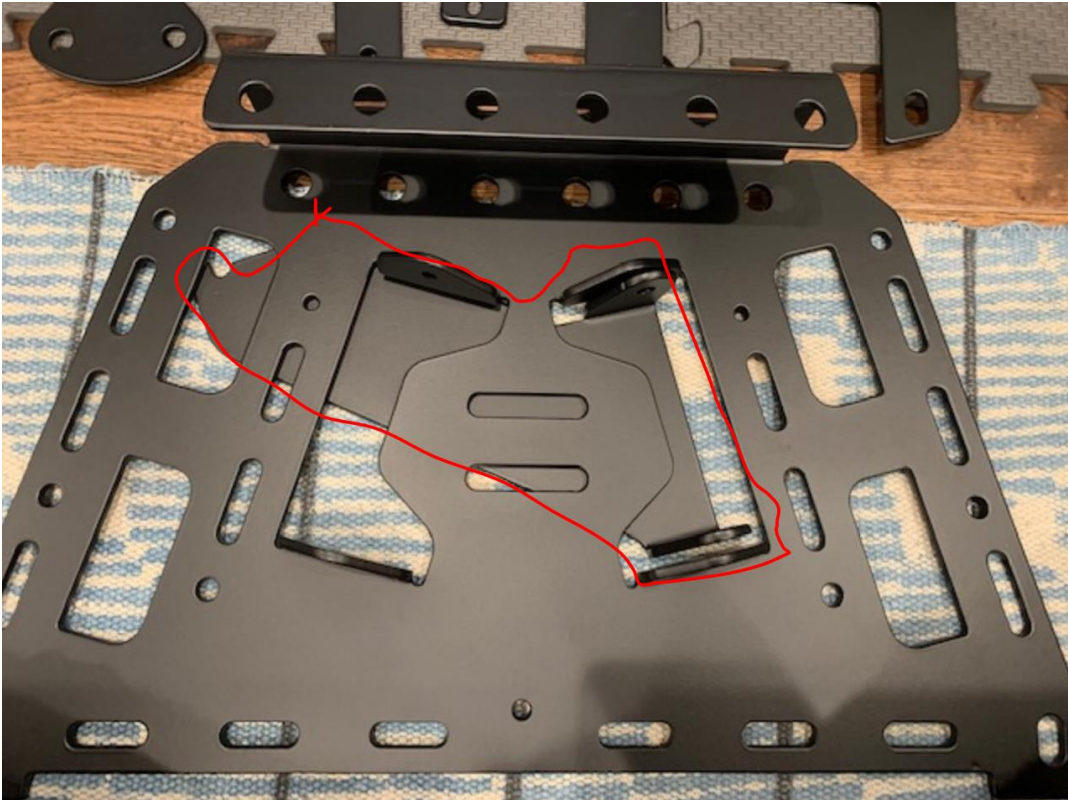



n) install the back plate on the front plate as pictured. Use the same orientation for the bolt heads. Always use bolt/washer/parts/washer/nut pattern

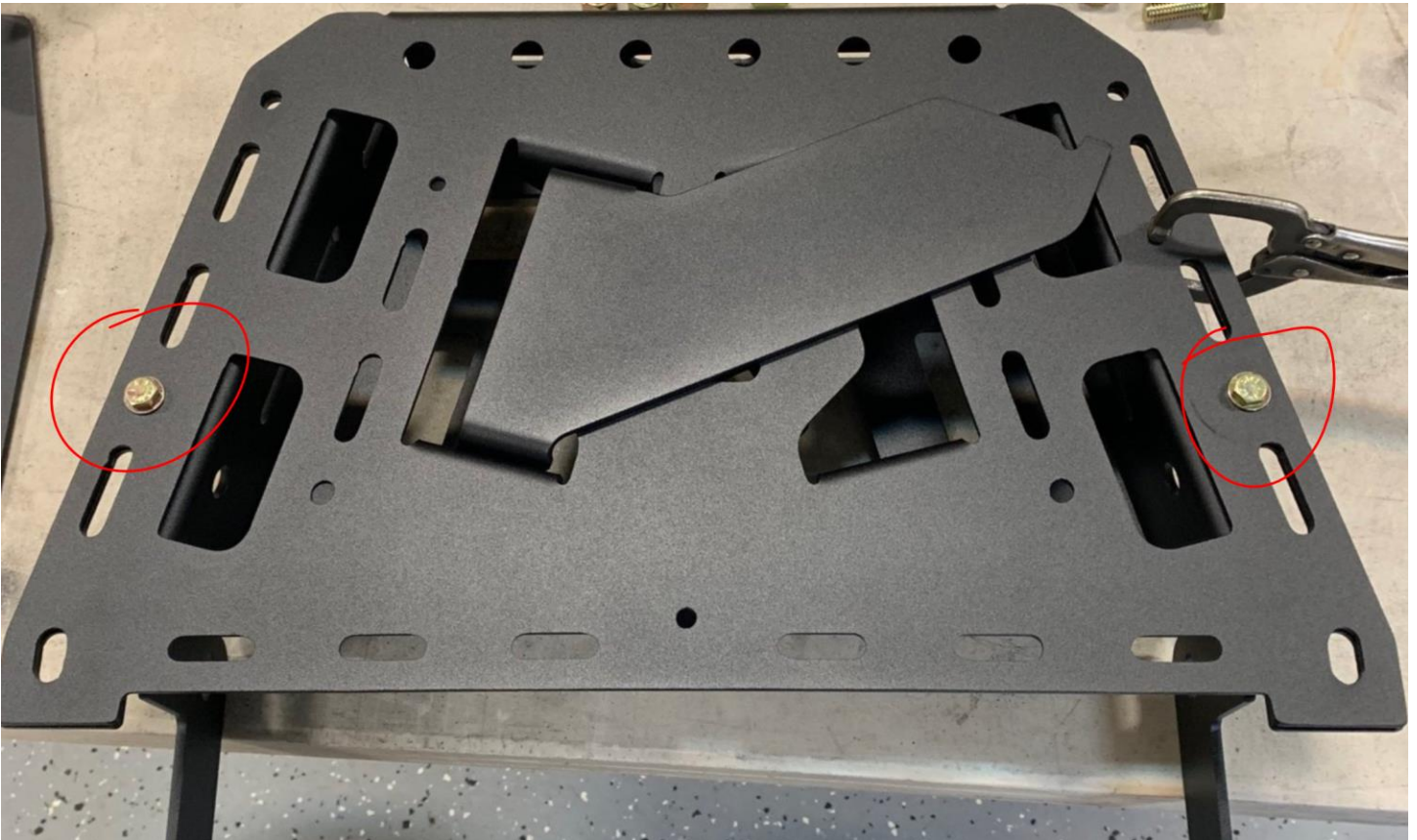

- install table brackets loosely

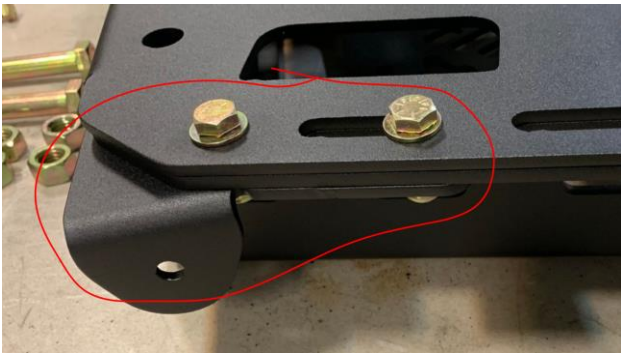

- install table latch.



- install table with nylon washers



- install foam on both sides of the table leg and over 4 lower bolts. Best way to do this is to cut squares and place them with the sticky side up. Then, close the table and press down to adhere 4 rubber squares to the table.
- Tighten all moving parts so they are snug, but still move freely
- Install swash plate



- Install tire carrier clamps



- Loosely install tire mount. Tire mount can be flipped 180 degrees from the photo to gain an additional 1" in height, if desired.



- **Install leg reinforcement plates**

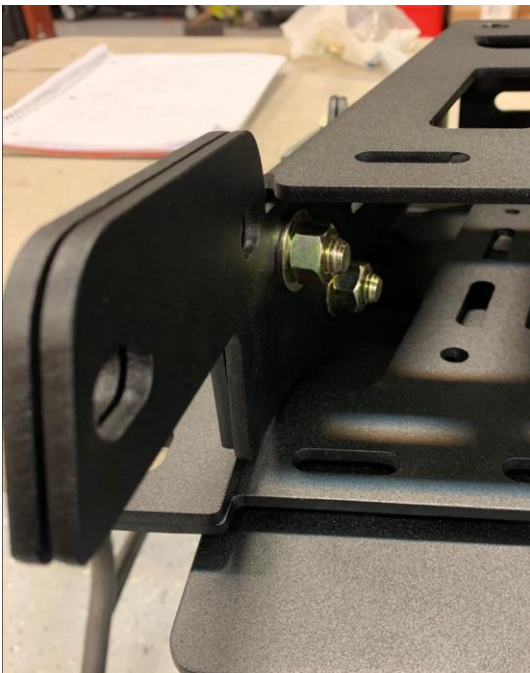

- **Tighten all bolts and and install assembly onto swing arm.**

- **When the tire is installed, it should be pushed in so the bottom is touching at the bottom side. The more angle that is desired on the tire, the more you will have to push the mount in.**





Trailer Towing

