

MICHAELCLOSE.COM

WHERE MAGIC AND TECHNOLOGY MEET



INTERVIEW

JOHN BANNON

*Michael asks John
about his new book!*

PAGE 8

REVIEW

VERY HUSH-HUSH

by John Bannon

PAGE 10



CONTENTS

January 2023 • Issue 1 • Volume 6

FEATURES

- 4 **UP FRONT**
- 7 **V.E. MAUGER'S MACHINE FOR TRIMMING CARDS**
- 8 **CONVERSATIONS WITH CLOSE**
JOHN BANNON
- 10 **PRODUCT REVIEWS**
VERY HUSH-HUSH
- 12 **MAGIC NEWS**
- 14 **COOL CLIPS**
- 15 **THE MAGIC OF SCIENCE**
- 16 **ELLIPSIS**
CARD BOX INS AND OUTS
- 22 **MIND OVER MATTERS**
- 26 **THE ART AND CRAFT OF CONJURING**



BIG NEWS!

Vanishing Inc shares its annual update along with some pretty big news.

12



JUAN TAMARIZ

Article about the godfather of card magic.

13



INTERVIEW

Michael talks to John Bannon about his new book.

8



NEW BOOK

John Bannon's new book, reviewed by Michael Close

10



DANI DAORTIZ

Watch Javi Benitez interview Dani DaOrtiz about his performance on Fool Us.

14



ELLIPSIS

Important card box handling. It's more important than you'd think.

16

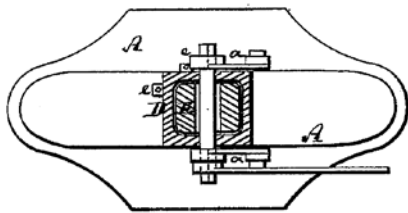

PATENT FILES

Clever, practical device for trimming cards.

7

UPCOMING CONVENTIONS

Magic Conventions Worldwide

- [MagiFest 2023 - Columbus, OH - Jan 26-28](#)
- [Mindvention - Las Vegas, NV - Feb 4-6](#)
- [Blackpool Magic Convention, Feb 16-19](#)
- [MagicCon: Philadelphia, PA - Feb 17-19](#)
- [NEMCON - March](#)
- [Winter Carnival of Magic , Tennessee Mar 9-11](#)
- [Houdini Festival, Virginia, Mar 23-25](#)
- [52 Friends, Hamburg, Germany, Apr 21-23](#)
- [AbraCORNdabra, Des Moines, IA, May 19-21](#)
- [IBM Convention, Pittsburgh, PA, July 11-15](#)
- [SAM Convention, New Orleans, LA, July 23-25](#)
- [MAGIC Live - Las Vegas, August 6-9](#)
- [Kid-Abra Conference, Chatanooga, TN, Aug 16-18](#)
- [World Magic Convention, London, UK, Sept 23](#)
- [Daytona Magic Convention - Nov 3-5](#)
- [London Magic Convention, London, UK, Nov 5](#)

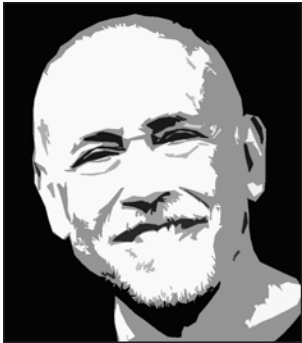

HOORAY JANUARY!

A happy belated new year to all of you from the Close clan, and thanks for joining us in 2023. Normally, for those of us in the Northern Hemisphere, January is a drab month, with the outlook of many more weeks of winter ahead. But this January is a cause for celebration, because a new book from John Bannon is on the horizon.

That's John on the cover this month, and his new book is *Very Hush-hush*, a collection of mentalism and mental magic card effects that require only minimal digital dexterity. John has the ability to squeeze every bit of juice from the methods he chooses for his effects, while, at the same time, effectively cloaking the principles behind those methods in logical presentations. You can read my review on [page 10](#).

I also had an enjoyable chat with John. We rarely see each other in person these days, so it was great to catch up and discuss a variety of topics. You can find a link to this edition of Conversations with Close on [page 8](#).

Speaking of magic texts about to hit the marketplace, my new ebook, *Mastering False Shuffles and Cuts*, is heading toward the home stretch. Right now, with a chapter and a half to go, I've written more than 16,000 words; there are almost one hundred photos and twenty-plus videos. The goal of this project is to offer all magicians, from beginner to advanced, a unique and carefully structured method for learning and mastering a variety of practical false shuffles and cuts (both in-the-hands and tabled). After my Zoom call with John Bannon, I showed him some of the items from the ebook; he was enthusiastic, which made me happy. Lisa and I are excited about this new product; we think it offers information and a method of training not seen in other books or videos on the subject. Look for it very soon.

In magic news, I'm happy to report that Teller has returned to the P&T live show in Las Vegas; it's great to have him back. The Maestro, Juan Tamariz, recently celebrated his eightieth birthday. Juan will be attending Magi-Fest in Columbus, Ohio, in just a few days. Josh Jay and Andi Gladwin, who produce Magi-Fest, just wrapped up another installment of their excellent The Session convention in London. I was invited to this gathering five years ago and had a great time. Below are a couple of photos from that occasion.



And, speaking of Josh and Andi, it was announced that Vanishing, Inc. had purchased the two remaining Houdini's Magic properties: the magic shop on Main Street in Disneyland and the magic shop on Pier 39 in San Francisco. You can read more about it on [page 12](#).

The buzz about Dani DaOrtiz's appearance on *Fool Us* continues. Javi Benitez (who had two wonderful performances on *FU*) interviewed Dani about the act. They discussed some aspects of Dani's routine that I have not seen mentioned in other sources. Watching the interview is definitely worth your time. You can find a link on [page 14](#).

In science news, researchers at Duke University and Arizona State University have created nanoscale structures (vases, bowls, hollow spheres) out of strands of DNA. How small are these structures? More than fifty thousand of them could fit on the head of a pin. This isn't just the world's toughest arts-and-crafts project, though. The software that creates these sculptures could also design carriers to deliver drugs or other medical uses. You can read more about this amazing accomplishment on [page 15](#).

I hope you have been enjoying Michael Perovich's Ellipsis column. It has always bothered me that these beautiful tidbits of finesse and technique get lost to memory if they're not recorded somewhere. Because Michael was active at the Magic Castle during its "golden age," he was privy to this type of information. I'm happy he's sharing it with all of us. This month he discusses a subject you might not have considered: how do remove a deck of cards from the card box?

Along with Michael, our other regular columnists are here this month: Bruce Kalver, Lee Asher, Mick Ayres, and Michael Breggar.

Before I sign off, I want to mention I have been doing Zoom lectures for various magic clubs around the US. I like doing these; in particular, I enjoy answering questions on a wide variety of subjects from the attendees. If your magic club would be interested in a lecture, drop me a note at mail@michaelclose.com.

That's it for now. Stay safe and warm. We'll see you next month. ♦



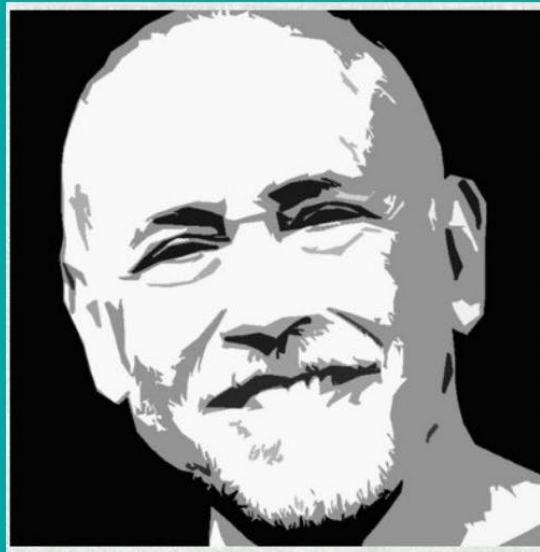

HOW MAGIC THEORY CAN IMPROVE YOUR PERFORMANCES

By Michael Close

HOW MAGIC THEORY CAN IMPROVE YOUR PERFORMANCES

Understanding and applying the powerful theoretical principles of magic can elevate your performances beyond your expectations. Because many theory books are densely written and contain few practical examples, magicians often avoid studying magic theory.

This New Targeted Training serves as an introduction to several of the most important theoretical concepts; in addition, the concepts presented can be easily applied to your existing routines.

Learn more at www.MichaelClose.com

START IMPROVING YOUR MAGIC TODAY VISIT MICHAELCLOSE.COM

V.E. MAUGER'S MACHINE FOR TRIMMING CARDS

by Lee Asher

FROM THE PATENT FILES

Playing card historians remember Victor E. Mauger for his import work with Goodall, then branching off on his own and creating beautiful cards like the Centennial pack. But the Mauger influence is much more profound when it comes to improving methods for playing card production.

His contributions are numerous.

For example, before playing cards got punched from strips in 1888, they were cut with industrial trimmers like the one Victor Mauger improved and patented in 1876. His new machine cut a pack of playing cards with great exactness and without leaving rough edges.

Clever, practical ideas like this helped Mauger excel in the playing card industry. ♦

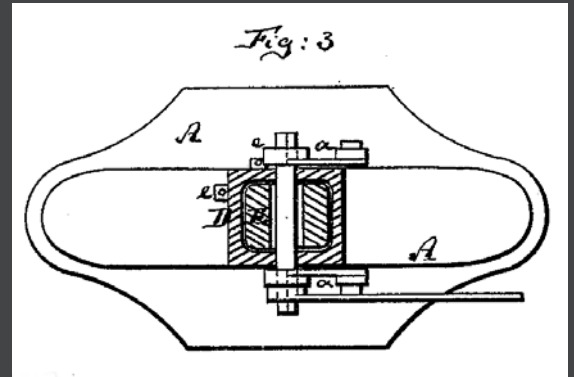

ABOVE: A diagram of Victor Mauger's machine for trimming cards.

UNITED STATES PATENT OFFICE.

VICTOR E. MAUGER, OF NEW YORK, N. Y.

IMPROVEMENT IN MACHINES FOR TRIMMING PLAYING-CARDS.

Specification forming part of Letters Patent No. 176,332, dated April 18, 1876; application filed March 4, 1876.

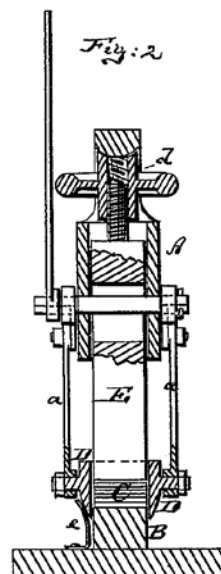
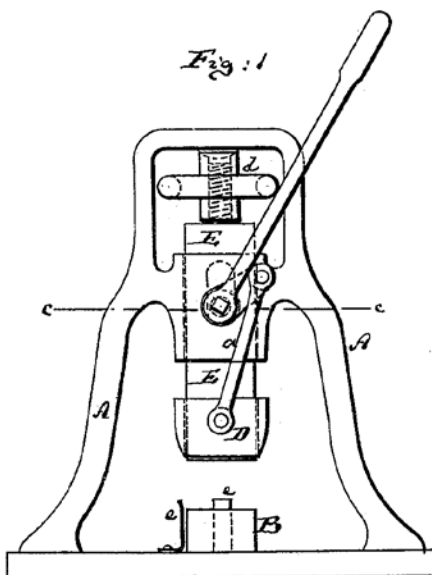

APPLICATION PATENTED
ON APRIL 18TH, 1876
PATENT NO. US176332
NEW YORK CITY, NY (USA)

WITNESSES: ERNEST C. WEBB &
F.V. BRIESEN

Inventor:
Victor E. Mauger
by his attorney
A. Briesen

Witnesses:
A. Moraga
D. Heidner

CONVERSATIONS WITH CLOSE

JOHN BANNON



If you are serious about close-up card magic, you probably have a John Bannon routine in your repertoire. I have several, including View from a Skill and Mexican Poker. John's books and videos are best sellers. He currently writes a bimonthly card column for Genii.

John's new book, Very Hush-hush, will soon be available through Squash Publishing. You can find my review on [page 10](#); spoiler alert: I really liked it.

John and I have been pals for more than thirty years. We used to see each other on a regular basis when I lived in Las Vegas, and later, when he would come to Toronto for the 31 North gathering. In this interview, we talked about his start in magic, his involvement with the Chicago Session (still going strong), and how he creates his effects. I think you'll find his comments insightful. Click [here](#) to listen to our interview. ♦

COMING SOON!



Mastering False Shuffles & Cuts Ebook

Master the art of false shuffles and cuts with this comprehensive ebook from Michael Close! This ebook includes detailed videos and photos, as well as ten amazing card tricks to use your newfound skills.

Get ready to take your card magic to the next level with False Shuffles and Cuts from MichaelClose.com

JOIN OUR MAILING LIST TO GET NOTIFIED AS SOON AS IT BECOMES AVAILABLE!

WWW.MICHAELCLOSE.COM

 DOWNLOAD

MAGIC FOR PROS FROM BRUCE KALVER

TSG - THE SMOKE GIMMICK

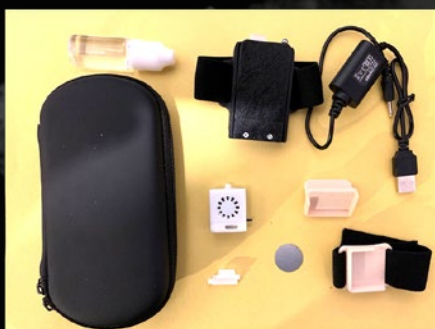
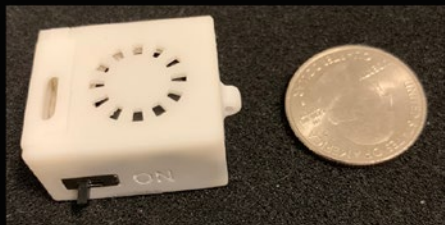

The Smoke Gimmick (TSG) is the smallest and easiest smoke producing gimmick you will ever use. ("1 x 1" ½)

The 3-D printed device can be held in the hand, or attached to one of the accessory clips to produce smoke wherever you need it!

The battery is rechargeable. TSG is remote controlled.

Some things you can do with the TSG include:

- A wisp of smoke when a coin or ball vanishes.
- A billow of smoke comes out of top hat or prop
- A borrowed smart phone begins to smoke when rubbed
- Smoke appears inside a glass or under a scarf.

As you see in the photo, we include lots of accessories so you can use it anywhere you wish to produce smoke.

Two drops of 'juice' gives you over a minute of smoke. The liquid supplied is available at e-cig stores everywhere. It is safe and you can travel with it. (travel case included.) Nothing complicated to set up. Press a button - get smoke. Detailed instructions along with a video guide is included.

Demo video at www.brucekalver.com. Available in VERY LIMITED quantities. Used by professionals.

\$ 130.00 (plus postage)

MAGICAL LITOPHANES



The word "lithophane" derives from Greek "litho", which is from "lithos" which means stone or rock, and "phainein" meaning "to cause to appear." Originally, lithophanes were made from carved porcelain but with modern 3d printing, the world of lithophanes are more affordable. Our unique pieces are 3D printed in plastic and take 5-7 hours to create.

With a simple LED tealight and stand, (supplied) the photo comes to life in an almost "holographic" appearance. We have also created a night light version which adds a little spookiness to your hallways. The night light version comes with an LED nightlight plug and adapter.

The Master Mystery Lithophane shows Houdini with the first robot in cinema, Q the Automaton Robot. Approximate size is 3.5 x 4.5 inches.

The Bosch Conjurer Lithophane shows the famous Bosch painting of a street performer presenting the cups and balls while robbers are stealing from the crowd. The graphic is approximately 3.5 x 5 inches. Lithophanes are \$25 each. Visit our website to learn more.

Top Hat Productions, PO Box 10421, Cranston, RI 02910 USA
www.BruceKalver.com | info@tophatprod.com

PRODUCT REVIEWS



VERY HUSH-HUSH

by John Bannon

Soon to be available from: www.squashpublishing.com

Price: TBD

Review by Michael Close

John Bannon is a prolific creator of high-quality magic (emphasis on card magic). His published works include *Impossibilia*, *Smoke & Mirrors*, *Dear Mr. Fantasy*, *High Caliber*, *Destination Zero*, and *Mentalissimo*. In cooperation with Big Blind Media he has produced several DVDs, including *Move Zero*, a four-DVD set focusing on self-working card magic. He also contributes a regular card column, “Dealing with It,” for *Genii*.

John’s new book, *Very Hush-hush*, follows a similar course to *Mentalissimo*: mentalism and mental magic with cards, with methods that require little or no digital dexterity. In a moment I’ll give an overview of what you’ll find in *Very Hush-hush*, but if you’re a Bannon fan, you’ll need no urging from me to pick up this book when it becomes available.

The book is in five large sections. The first section, “Parts of the Sum,” begins with a deep dive into Magic Square effects using playing cards. In the first two effects, Cloud Nine and Psymphathetic, John has increased the commerciality of the routines by using a three-by-three Magic Square (rather than a four-by-four) and the revelation of the square (and its properties) comes as a surprise, rather than a pre-announced goal. Additudinal and London Calling utilize the principle of Jack London’s Almost Real Prediction without any of the mental headaches Jack’s original method required. Sum Kind of Wonderful combines the method of Larry Becker’s Sum Total with the one-ahead principle to predict a six-digit number created by the spectator. Again, very little mental dexterity is needed. Sweet Sixteen uses the same procedure to “predict” a four-by-four Magic Square that adds up to a freely selected number. The chapter concludes with Prime Directive, a Magic Square effect that doesn’t use numbers (no kidding)!

Section Two, “Karmaholic,” features ten impossible-location effects. In all of these, the underlying methodology is well concealed, and none of them are difficult. Even better, quite a few of these can be done over Zoom; with the uncertainty of how long in-person gatherings will continue due to new varieties of the Covid virus, it’s good to have several effects of this caliber in your repertoire.

Section Three, “Ghost in the Machine,” contains ten prediction effects that combine simple equivoque with clever multiple revelation procedures. Those of you who do memdeck work should pay particular attention to John’s Vicinity Switch. It will be a valuable addition to your Riffing toolbox. In Prophet Margin, John combines the Vicinity Switch with the Bill Simon Business Card Prophecy move; don’t pass this by without trying it. One of my favorite effects of this section, Swindelicious, uses the Paul Curry Swindle Switch procedure in an absolutely devious way.

Laymen don't stand a chance with this routine; it might also fool your magic pals. Stone Soul Picnic and Liars Al Fresco take the venerable Poker Players' Picnic and turn it on its head – very, very clever.

Section Four has six routines with a prediction theme. The first, Double-Barreled, uses a U.F. Grant non-card principle in a way I've not seen utilized before to produce a double prediction. The routines in this section involve some low-level sleight of hand, but nothing that you won't get under your fingers in a day or two, even if sleight of hand isn't your thing.

Section Five, Singularities, has four performance pieces and a useful move (the Las Cruces Force). The routines are baffling and memorable. Take the time to work through them (OMG Super Morigami! is a favorite).

As I mentioned to John in my interview with him (see [page 8](#)), I regularly use several of his self-working routines when I'm asked to do magic in an impromptu setting. I know I'll be adding routines from the new book to that set list. Squash Publishing is releasing the book, which, at the time of this writing, is en route from China. It should be available shortly; check the Squash website for ordering information.

Very Hush-hush is another winner from John Bannon. For those of you looking for baffling routines that won't bust your chops, or for lovers of elegantly constructed card magic, this book is a must-buy. Highly recommended. ♦

MAGICIAN MERCH

AVAILABLE NOW!

MICHAELCLOSE.COM

The advertisement features a central graphic with a pink-to-yellow gradient background. On the left, a woman wears a white hoodie with the word 'MAGICIAN' repeated four times in a vertical rainbow color gradient. Below it is a black hoodie with the same design. In the center, two white mugs are stacked, each with the 'MAGICIAN' rainbow design. On the right, a white t-shirt and a white mousepad with a black mouse are shown, both featuring the 'MAGICIAN' rainbow design. A black button with the text 'AVAILABLE NOW!' is positioned above the mugs. At the bottom, the website 'MICHAELCLOSE.COM' is written in large white letters.

MAGIC NEWS

VANISHING INC HAS BIG NEWS!

From Andi and Josh, "Let us paint a scene for you: it's February 2022 and we just completed an exhausting day of filming for the television show *Masters of Illusion* on set in Los Angeles. We conspired to film it at the same time because we were helping each other with our segments. After a stressful filming day, we treated ourselves to a rare day off, and the two of us went to Disneyland. As we entered the park, the very first stop was a quick trip into the Main Street Magic, the famous shop in Disneyland where so many fine magicians got their start.



"As we chatted with the demonstrator behind the counter, it became clear that the shop was in a transition period. He explained that the owner of this shop—which was one of two branches of the well-known Houdini's Magic Shop chain—was winding down his operations and would, perhaps, be interested in selling. Until that moment, neither of us had ever given any serious thought to owning and operating a retail magic shop. It was a dream, but we weren't sure it would ever be a reality."

Read this story and the whole annual update [here](#).

SISTERHOOD PLAYING CARDS UPDATE



Rosemary Reid successfully funded the SISTERHOOD Deck of Playing Cards with generous support. The project raised \$20,665 CAD with 293 backers, funding 232% of the Initial Funding Goal. Congratulations!

LOOKING FOR MAGIC IN YOUR NECK OF THE WOODS?

You've heard of the biggest magicians and illusionists of our time who perform with those big Las Vegas Illusion shows or New York Magic Shows, but there's more to magic than the handful of performers that have huge marketing budgets. Today, you can see magic and illusions shows in almost every part of the United States that are fabulous and a real treat for a special evening out. [Check out this great site](#) that lists magic shows in your state.

PIFF, DONNY OSMOND SHOW 'PUPPY LOVE' TO PIFFLES

Nov 16, 2022 - John Katsilometes - Las Vegas Review Journal

You know it's a landmark night when a superstar headliner says to the crowd, "This is what my career has come to."

So give it up for Donny Osmond, who once had a hit with "Soldier of Love," for soldiering on as he sang "Puppy Love" to Mr. Piffles. This is the celebrated, chihuahua sidekick of Piff the Magic Dragon and Showgirl Jade Simone, who celebrated his 15th birthday on Monday night. The place was packed for this One Dog Night performance. Read the article and watch the video [here](#).

THE MAN WHO MADE SPAIN THE MAGIC CAPITAL OF THE WORLD (PAYWALL)

INSIDE THE MIND OF JUAN TAMARIZ, THE GODFATHER OF CLOSE-UP CARD MAGIC

By Shuja Haider - Jan. 2, 2023



Going out to dinner with Juan Tamariz in Madrid is a little like accompanying a cartoon character on a journey to the real world. As I walked with the 80-year-old magician on side streets off the city center's main drag, the Calle Gran Vía, heads turned left and right. Tamariz has been a professional magician for 52 years, and in that time, he has managed the singular feat of becoming both a household name in his home country and a living legend in magic everywhere. He is referred to by magicians all over the world, and waiters all over Madrid, as Maestro. David Blaine has called him "the greatest and most influential card magician alive." But in Spain, Tamariz is an icon, less like Blaine or David Copperfield and more like Kermit the Frog. Read [here](#).

THE BEST MAGIC SHOWS IN NEW YORK CITY

In magic shows across the city, some of the world's best illusionists help make New York a city of wonders

Adam Feldman - Nov 26, 2022

We all need a bit of magic in our lives, and New York offers plenty to choose from beyond Harry Potter and the Cursed Child. Some of the city's best magic shows are proudly in the old presentational tradition of men in tuxedos with tricks up their sleeves; others are more like Off Broadway shows or immersive theater experiences. When performed well, they welcome you to suspend disbelief in a special zone where skills honed over the course of years meet the element of surprise. Why not allow yourself a few illusions? Read the article [here](#).

COOL CLIPS

[THE DANI DAORTIZ FOOL US ACT INTERVIEW WITH JAVI BENITEZ - A MASTERCLASS!](#)

Interview to Dani Daortiz about his own Amazing Penn & Teller Fool Us Act. This is a Masterclass in magic performance and spectators control.

This is probably the greatest Fool Us act in History and I ask him all the questions you've been wondering about it! In this interview, you'll get to hear from the man himself about the act, his motivations, TV and his reaction to it all! Pure gold in here to better understand what good magic is.



[THE EIGHTEENTH-CENTURY SELFIE | CHARLES BURNS | TED TALK](#)

Cutting silhouettes isn't exactly magic, but it certainly is an adjunct art form. Through much of his life, Dai Vernon's day job was cutting silhouettes. Here's an interesting Ted Talk on the subject.

In these modern days, we upload our selfies and profile pictures everywhere. But have you ever taken the time to study what your face looks in profile? Over the last twenty-five years, Charles Burns has cut over 200.000 silhouettes of people he has met.



DESIGNING WITH DNA

December 26, 2022 - Duke University

Software lets researchers create tiny rounded objects out of DNA

Marvel at the tiny nanoscale structures emerging from research labs at Duke University and Arizona State University, and it's easy to imagine you're browsing a catalog of the world's smallest pottery.



A new paper reveals some of the teams' creations: itty-bitty vases, bowls, and hollow spheres, one hidden inside the other, like housewares for a Russian nesting doll.

But instead of making them from wood or clay, the researchers designed these objects out of threadlike molecules of DNA, bent and folded into complex three-dimensional objects with nanometer precision.

These creations demonstrate the possibilities of a new open-source software program developed by Duke Ph.D. student Dan Fu with his adviser John Reif. Described December 23 in the journal *Science Advances*, the software lets users take drawings or digital models of rounded shapes and turn them into 3D structures made of DNA.

The DNA nanostructures were assembled and imaged by co-authors Raghu Pradeep Narayanan and Abhay Prasad in professor Hao Yan's lab at Arizona State. Each tiny hollow object is no more than two millionths of an inch across. More than 50,000 of them could fit on the head of a pin.

But the researchers say these are more than mere nano-sculptures. The software could allow researchers to create tiny containers to deliver drugs, or molds for casting metal nanoparticles with specific shapes for solar cells, medical imaging and other applications.

To most people, DNA is the blueprint of life; the genetic instructions for all living things, from penguins to poplar trees. But to teams like Reif's and Yan's, DNA is more than a carrier of genetic information -- it's source code and construction material.

There are four "letters," or bases, in the genetic code of DNA, which pair up in a predictable way in our cells to form the rungs of the DNA ladder. It's these strict base-pairing properties of DNA -- A with T, and C with G -- that the researchers have co-opted. By designing DNA strands with specific sequences, they can "program" the strands to piece themselves together into different shapes.

The method involves folding one or a few long pieces of single-stranded DNA, thousands of bases long, with help from a few hundred short DNA strands that bind to complementary sequences on the long strands and "staple" them in place.

Researchers have been experimenting with DNA as a construction material since the 1980s. The first 3D shapes were simple cubes, pyramids, soccer balls -- geometric shapes with coarse and blocky surfaces. But designing structures with curved surfaces more akin to those found in nature has been tricky. The team's aim is to expand the range of shapes that are possible with this method.

Read more about this interesting research [here](#). ♦

ELLIPSIS

BY MICHAEL A. PEROVICH

Michael Perovich is a retired civil engineer and a highly accomplished amateur magician. He was a columnist for M-U-M and has contributed routines to Genii, Talisman, and The Ganson Book. He is the author of the excellent memoir, *The Vernon Companion*. He is an active member of SoCal Sodality and the Academy of Magical Arts.



CARD BOX INS AND OUTS

We're going to discuss something no one talks about. If you stick with me, I hope you'll agree the items below are quite important and deserving of our attention. The subject is how a deck of cards is best removed from its box and how it can be neatly returned. As I've previously mentioned, more people watch a performer when he is between effects than the performer may realize. The performer may believe the audience's attention is suddenly focused elsewhere, but that is seldom the case. Therefore, it is worthwhile to consider not just the card effects we perform but how the deck is brought out and how it is put away. An audience may not be consciously aware of

these things, but they will register if you fumble in either of these two endeavors.

I'll focus on how four prominent magicians of the fairly recent past dealt with this issue, each in a different way, consistent with their persona. I'll also discuss each method's impact on the audience.

CALM, COOL, AND COLLECTED

The first method is by Jay Ose, a magician who had passed away only a year or so before I first visited the Magic Castle. Virtually everyone I met there spoke glowingly of Jay; his presence seemed to hover over Castle members for years after his passing.

The most common and seemingly the most natural way for a person to remove cards from a box is to open the flap at the top of the box, pinch the deck between the forefinger and thumb (where the double crease in the lid and the semi-circle opening in the front of the box allow it), and neatly extract the cards. There is nothing wrong with this, although there is a tendency to be a bit awkward as the cards are removed and re-gripped.

I've noted several magicians through the years who handled objects so neatly and efficiently that the viewer was almost hypnotized by the manner in which various things were held, picked up, put down, or transferred from hand to hand. Coe Norton and Don Lawton come to mind, and to some extent Jay Ose fit into this mold as well. As he spoke, the low key Mr. Ose removed the cards from the box in a pretty much standard way and placed them on the table. As he continued his introductory remarks, he took up the now empty box and very calmly reinserted the flap into the box, returning it to the appearance it had prior to removing the deck. He then placed the empty box aside and out of the way.

I'm not sure I've ever seen anyone else do this, but I think it subliminally communicated to the audience that there was a place for everything and that everything would be put in its place. Also, it communicated that Mr. Ose was going to be deliberate in his manner, that he was not nervous, and that he knew exactly what he was doing. He wasn't rushing into his first trick, but rather setting the stage both through his comments and his actions. I doubt that anyone truly noticed that he had taken the time to neaten up the box and gently place it aside. Even so, I think this action put the

audience in a different place than they had previously occupied and offered a gentle buildup to the first effect he performed. The audience was gradually drawn into his web; they were focused as his first trick began with a neat and orderly table set before them.

ELEGANCE IN MOTION

Michael Skinner was, of course, a very accomplished close-up magician whose ability at sleight of hand exerted a calming yet mystifying influence over everyone who saw him perform. I'll preface his technique of removing the cards from the box with a brief story.

My uncle Al was a rancher for most of his life. As he grew older, however, he turned to real estate as the rigors of driving a tractor through a vineyard in the one-hundred-degree heat of California's central valley lost some of its charm. He constantly saw the light side of people's actions and motives; on the one occasion he visited the Magic Castle, he was more interested in watching the idiosyncrasies of the crowd than the magicians in the showrooms. He once laughingly told me that part of his real estate training involved learning the seductive actions by which a potential buyer could be induced to sign on the dotted line.

He was taught to engage the buyers in positive conversation, congratulating them on their choice of a new home. As their eyes met, he was to hold up his pen horizontally, directly between his eyes and the buyers. Once the buyers focus had shifted to the pen, the glimmering tube was slowly but steadily moved down to the signature block as Uncle Al's body language shifted the buyer's attention to the dotted line on the contract. The idea was to time the comments about signing and the pen's movement to the signature line so as to create an irresistible urge to put pen to paper. This needed to occur before the buyer had time to ask yet another question or concoct some other reason to delay signing the contract.

Michael Skinner used this same basic concept to capture the audience's attention before the cards were even out of the box. This occurred as the boxed deck was brought forward and held horizontally a foot or so above the center of the table. As one hand held the box with the cards inside, the thumb of the other hand came forward and snapped the box flap open (Photos 1 and 2).



Photo 1



Photo 2

Bang – the lid had now been dramatically opened; the snapping hand immediately pulled the

ellipsis cont'd

deck about halfway out of the box (Photo 3). This hand was now repositioned with the palm up, the thumb on one side of the exposed deck and the index and middle fingers on the other (Photo 4).



Photo 3



Photo 4

With the card box still held horizontally, the pack was deftly pulled forward from the box until it dropped elegantly into the waiting hand (Photo 5). The trick hadn't started, but everyone's eyes were glued to that deck of cards just as Michael entered into his first effect. They were ready to sign on the dotted line.



Photo 5

I'm not sure how Jack McMillan took the cards out of the box, but I remember that he removed the Jokers from the pack and, as he tossed them aside, commented that he was the only joker to be concerned about. He had a gentle charm that, for some reason I can't be sure of, caused people to crane their necks in an effort to see what he was doing. Suddenly everyone's interest level was amped up and they wanted to see just what was going on. There was no challenge and no sense of showing off. Just the sense that something interesting was about to happen and you didn't want to miss it.

THE WHISK AWAY

Bruce Cervon had a method of removing the cards from the box whose impact was almost the opposite of those we have described to this point.

When I first met Bruce Cervon, I thought he must have once worked in a carnival. As it turned out, he had. Bruce was all about fooling people; while many of us spend our time trying to distract our audience, Bruce was always admonishing them to watch closer. "Get closer. Look! Now

watch,” Bruce was constantly saying. He moved quickly, in a studied but somewhat herky-jerky manner, where every move was a sure move. When it came to opening a deck of cards, he opened the box’s lid and pinched the deck with the thumb on top and the fingers on the bottom. Then, suddenly, while the deck stayed still, the box was whisked away. This was done with a very quick, long sweeping motion of the hand taking the box (Photo 6).

One moment the box of cards was held before the audience; in the next instant the hand held only the cards and the box was gone from the scene, out of the spectators’ view. Bruce had other ways of removing the cards from the box, but none more dramatic than this. It had the effect of suddenly yanking a cloth away to reveal a surprise. The audience was somewhat taken aback and put a bit on the defensive, as was the intent.



Photo 6

THE LAST JUJUBE IN THE BOX

Dai Vernon wanted the magic to speak for itself. He wasn’t about deft hand movements and snazzy flourishes when he performed close-up card magic. The method he used to remove the cards from the box was in keeping with his utilitarian approach to card handling.

Vernon opened with some humble but amusing remarks and, unlike the others, held the box up vertically, almost to shoulder height, once the flap had been opened. He held the cupped hand that was about to receive the cards below the box’s opening with the thumb near the semi-circle and the four fingers in the back pressing the opened lid out of the way. He then allowed the pack to slide out into his waiting palm. Typically, he shook the box to get every last card out just as a movie theater patron might shake the last piece of candy from an almost empty box (Figure 7).



Photo 7

This was very disarming. It was not the action of someone who was about to cheat you, or make fun of you, or bamboozle you. It was the action of a mature gentleman who was going to show you something he thought you might enjoy. And he was right.

Interestingly, Channing Pollock produced the pack in a way that blended these last two techniques. He held the end of the deck still in the vertical box and then pulled the box up and tossed it away, immediately making a one handed fan with the pack that remained in his hand. As

ellipsis cont'd

with so many things Channing Pollock did, this was effective in great part due to the economy of movement he employed.

Well, now that we have found a way to get the cards out of the box without dropping them on the floor and amazed our audience with our conjuring skill, the time has come to put the cards back in the box. For many magicians, this is a monkey-with-a-football moment. Suddenly, it seems the pack is too big for the box. We can't seem to get them all in at the same time, those little side flaps are constantly in our way and we run out of clever patter before we can cram the obstinate pack back into its little home. Believe it or not, this isn't the suave finish the audience was hoping for. The audience may even feel drawn to leap from their seats to assist you. "They were in there a minute ago, I'm sure we can get them back in if we all push together."

Putting the cards back in the box is something we should practice as assiduously as anything else we do. For many of magic's cognoscenti, it is an accepted practice to tear off those little side tabs, more correctly called "ears," to facilitate the return of the pack into the box. It somewhat disturbs me to do this so I'll give you another method that will facilitate this replacement without damaging the box.

In this method, the ear furthest from the performer is permanently bent down and the pack is always placed in the box with this ear pressed against the side. Only the ear nearest the performer's body is folded over the pack when the flap of the lid is pushed home. The pack is held perfectly squared in one hand with most of the pack hanging down below the thumb and first two fingers. These fingers hold the pack by the tops of the long edges. The other hand holds the box with the thumb in front and three fingers on the back of the box. The index finger sweeps up to simultaneously hold the lid and the near ear up and out of the way (Figure 8). The lower far corner of the pack is now inserted near the far end of the box using the bent ear and the sloped exposed lid as sort of a slide (Figure 9).

The pack is levered up and into the box with the ear held up by the forefinger allowed to flip back along the top of the pack once it slides cleanly into the box. It is helpful to squeeze the sides of the box to create a gap for the flap to enter (Figure 10).



Photo 8



Photo 9

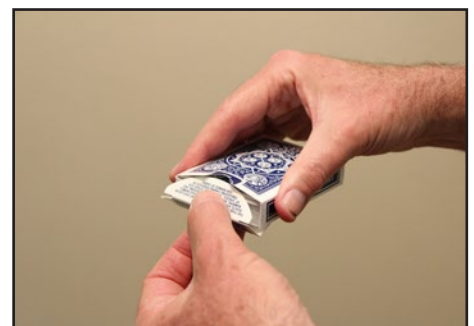

Photo 10

Voila! ♦

OTHER EBOOKS FROM MICHAELCLOSE.COM:

MAGIC IN THE REAL WORLD EBOOK by Christian Painter

If you're a magic enthusiast, and you'd like to turn your hobby into your job, this new ebook by Christian Painter, should be your next purchase.

This may well be the most practical ebook for the aspiring professional magician ever published. This ebook will save you time and money, and will increase your odds for success.

MichaelClose.com
Where Magic Meets Technology

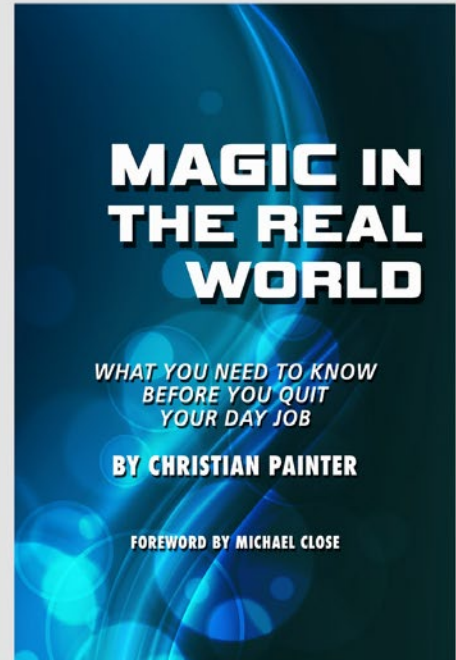

\$24.99 USD
Instant Download

THE PM CARD MARK SYSTEM BY PETE MCCABE

An easy to learn card marking system and twenty-eight routines designed to baffle even those familiar with the concept of a marked deck. The routines include either a full script or patter suggestions for turning the routine into a full-blown performance piece. Includes additional material by Michael Close.

**Instant
Download
\$24.95**



AVAILABLE NOW - CLICK HERE FOR DETAILS

**MAKE YOUR OWN
MARKED DECK**

MIND OVER MATTERS BY MICHAEL BREGGAR

Michael Breggar has authored five books (focusing on card magic and mentalism) and is a columnist for The Linking Ring ("Auto-Magic"). You can find his books at www.mjmmagic.com



Sometimes even the smallest of ideas can stimulate your thinking. And that can lead to some interesting and interestingly surprising routines. When I test drive new routines, I place them in second or third place in my act. I have just done a wonderful opening routine and the audience begins to feel a level of comfort with me. So, a moderate amusement works well here. I save my best effect for next to last and my most memorable for last (sometimes my final effect is both the best and the most memorable). Meanwhile, I gauge the response of the new routine and eventually decide what to do with it: keep it in the program, move it later in the order, pull it and work on it re-entering it at another time, or pulling it and finding the

nearest paper shredder.

This month's effect came from an interesting morsel of a concept I remember reading many years ago (I believe it was part of a Leslie May trick published in Peter Warlock's *New Pentagram*. That would place its origin in the early- to mid-1970s). Whatever the trick was, it was just okay. There was a certain element that sang to me. I needed to try out the principle right away and work on a routine using it.

What is this amazing, life-reaffirming principle? Don't close the tab when you read this...

If you place a stack of cards in a lunch-size paper bag, you can shake the bag and its contents to your heart's content and the cards' order will remain the same.

Yes, really! The cards will look sloppy and will be jogged and spun at random angles, but the positions will be retained.

Try it out. Get a lunch-size paper bag (usually 11.5 by 5 inches); even the paper bags used at most fast-food joints will work. Now take a deck of cards in some known stack order (or simply have the first thirteen cards in Ace to King order). Place the open bag on a flat surface and drop the deck in. This action is a "dropping" action: that is, let the pack drop as a unit to the bottom of the sack. After a few trials you will be comfortable enough to execute this action much more deceptively. You spread off the bottom third of your card set and drop them into the bag. Then another third from the bottom and drop them. Finally make a sloppy little fan of the remaining cards, close this fan somewhat, and let them drop into the bag. (This is sort of like a "bagged Ose" false cut.) Your audience helper can even look into the bag (before and after) and see nothing out of the ordinary – just a mess of cards in a plain paper bag. You could say, *"I don't know if you are a good, thorough shuffler, but I am sure you wouldn't trust li'l ol' me with shuffling the cards."*

So now instruct her to close the bag and roll the top down a few times. Then she is to hold the rolled top of the bag and give it a good shake. *"It's a great way to completely mix up the cards and get some exercise in at the same time!"*

You can then open the paper sack and continue with any effect where you need the cards in some order, because nothing will have changed!

THE JOY OF SACKS

The following interesting effect utilizes this principle. I was very unsure of its impact. It stayed in position two or three in my mental set for the longest time as I continued to toy with it. I discovered

it was most effective, when I stripped it to the bone, pulling out a lot of the superfluous nonsense I typically throw into my routines to make them play funnier.

But that's okay. It is totally mystifying.

You show a deck of ESP (Zener) cards. Turning them face-up you roughly spread them from hand to hand (that is, spreading in uneven groups so no pattern can be discerned). The deck, though, is set up in the standard ESP-deck stack order of CIRCLE, CROSS, WAVY LINES, SQUARE, STAR repeated five times.

As you spread you comment, *"The standard ESP deck has twenty-five cards: five stars, five crosses, five circles, five squares, and five sets of wavy lines. I can mix up all these cards this way..."* and I do a Charlier shuffle (spread a few cards from the top of the left-hand packet to the right hand. Then spread a few from the packet's bottom and put them on top of the right-hand cards. Spread a few more from the top of the left and place on the bottom of the right-hand packet. Then bottom to top and top to bottom again until the cards on the left are exhausted. All of this merely cuts the packet, leaving the cards in the same rotational order.)

You continue, *"...or I can really be certain the cards are thoroughly mixed this way..."* And now I do the false "shake and bake" bit with the paper bag. The technique where I toss in a third from the bottom, then middle third, and then the top third is particularly effective here. I do a few shakes with the closed bag and then hand the bag to a spectator to shake some more. Taking the bag back, I remind everyone of the five symbols *"now scattered who knows where."* I take a broad-tipped marker pen and draw the symbols on the bag, so the audience has a visual reminder as well.

I now ask five or six members of the audience to call out any of the five symbols; it doesn't matter if there are any repeats. I turn the bag around and write this "list" of selections in the order called on the back of the bag. *"You all clearly selected these symbols at random, am I right? And those symbols have been scattered mercilessly through the whole lot o' shakin' goin' on. Still, I will use my psychic superpowers to find the symbols you called out – in the order you called out – without even looking at the mess in the bag!"*

You now unroll the top of the bag and with your head turned (or wearing a blindfold or sleep mask) reach into the bag. At an increasing pace, one by one you pull out the symbol cards called by the audience in the order called as listed on the bag. They may laugh at the first couple, but as you keep pulling out the correct cards their seats will empty; they will be falling out of them!

The method should be obvious given the above description of the false bag mix. A few notes are in order. First off, right before you toss the cards into the bag, you will need to catch a glimpse of the card at the bottom. It's easy to do this surreptitiously. As you drop that first batch, turn the backs a bit towards the audience. You'll do the glimpse in full view of the audience, and they won't even realize it because everything else happens so quickly and so fairly (seeming). Since you haven't changed the cyclical order of the repeating five-card stack, if you know the bottom card, you'll know the one on top. And since you know the card on top, it is a simple matter to count down to the selections. I use the space around the cards in the bag as a "working area." This allows me to push the cards aside as I count down to fetch the cards I need. I pull all the called cards as soon as I dip my paw into the bag. I then place them on top of the deck. This lets me easily manage the increasing pace as I pull the cards out. And since the first reveal happens slower, I can take all the time I need to set things up inside the bag.

One final note: after I pull the cards I need and set them on top of the bagged deck, I gleefully,



MichaelClose.com
WHERE MAGIC AND TECHNOLOGY MEET

THE PARADIGM SHIFT EBOOKS

Groundbreaking essays that will change the way you think about your magic, beautiful sleights that will deceive both laymen and magicians, and commercial, devious routines you will enjoy performing. Text, photos, and video to provide an optimal learning experience.

"If you genuinely want to be a better magician, this is the book for you." —Gareth B.

"Great deal and fantastic material." —Joseph N.

"The Paradigm Shift (both volumes) are ridiculously underpriced for the gems they offer. Beautifully assembled and spectacular in content." —Michael M.



Download your copies today at MichaelClose.com

THE ART AND CRAFT OF CONJURING BY MICK AYRES

The Five Dollar Trick copyright 1976 by Mick Ayres. Mick is a trickster, tunesmith, and tale-swapper for the Walt Disney Company. Feel free to reach him at mick@mickayreswares.com or via Facebook.



“Worry is a god, invisible but omnipotent. It steals the bloom from the cheek and lightness from the pulse; it takes away the appetite and turns the hair gray.” – Benjamin Disraeli, author

It is never good to worry. Worry causes stress, increases blood pressure, makes one perspire beyond reason, and makes one forgetful – especially on stage. Yet for all we do to stop ourselves from worrying, every person does it. This means every person is intimately familiar with the emotion.

So even though it is never good to worry, there are still times when an actor playing the role of a magician needs to convey anxiety to his or her audience because the script and plot require it. Just like the “magician-in-trouble” scenario, anxiety is not something to pass off lightly when on stage. When a theater performer gives anxiety a limp effort, the audience will pick up on it quickly – and therein lays the harm. The guests have been reminded you are faking it on stage. In that moment, you have yanked them out of the story and back into the hard world of reality.

In the world of conjuring, escape artists should be noticeably worried every time they are being restrained. What if they cannot escape? Grand illusionists should be filled with anxiety every time they put a blade in the box with the lovely assistant inside. What if something goes wrong? Even close-up entertainers should exhibit concern about the outcome of an Any-Card-at-Any-Number presentation. Yet all too often, these dramatic moments are ignored by magicians who lack the showmanship to understand the potential of what they are missing.

Do not to fall into the trap of over-acting. Anxiety causes recognizable signs of fear and panic in varying degrees. According to physicians, obvious signs include an increased heart rate, sweating, trembling, shortness of breath, difficulty with swallowing, nausea, and lightheadedness. Obviously, a magician who is anxious about the result of a card trick should not fake a heart attack or vomit on stage. However, to pause and swallow hard in the middle of a sentence would convey the emotion well enough. Another example would be to change the rhythm of one’s speech to imitate shortness of breath. Perhaps a brief stumble while wiping the back of one’s hand across the brow would communicate without words that you are worried enough to perspire and feel dizzy. Less is more; but to convey believable worry, a bit of acting along with scripted words will give a touch of realism to the emotion you are trying to communicate.

The following drama is a perfect blend of acting and conjuring because it creates a “magician-in-anticipation” scenario. In other words, it will be necessary to act worried about a potential situation that is not yet evident to the audience. This scenario is critical to the dramatic success of the effect, so the moment is not something to gloss over on stage. Since the method is relatively self-working you will have plenty of room to stretch out your acting muscles and consider just how much drama you wish to create.

Sell it so they will buy it.

CHERRY-PICKING

In this demonstration of precognition, a guest gets a brief glimpse into her own future by accurately predicting the results of her own decisions over the next few moments. You only require a deck of cards that has been assembled in the Si Stebbins order (the cards are in Clubs, Hearts, Spades, and Diamonds order with an added value of three from one card to the next).

Say, *“When a farmer harvests a crop and brings it to market, he puts the ripest produce on top of every crate. It’s called ‘cherry-picking’ because it gives the impression the whole crop is just as ripe and healthy. Today cherry-picking also describes someone who makes a point by using only supportive information and ignoring anything that would contradict it – for example, when a political party claims their lousy candidate is better than the other party’s lousy candidate, or when the news networks want a story to seem more important than it really is. Senior citizens will cherry-pick when talking about their grandchildren. You cherry-picked the last time you wrote a resume. I did it when I put this show together. We do it without thinking. Let me show you.”*

Remove the deck of cards and display them as mixed to the audience. The way to do this with a deck in Si Stebbins order is to spread a few cards into your right hand and then hold the spread up so the guests can see the faces briefly. Then spread a few more under those already in your right hand and hold the spread up again. Do this casually without rushing three or four times. People tend to focus on the face card of the spread each time and will not pay attention to the alternating red/black pattern. Square the pack and put it face down on the table.

Say, *“First, you are going to cherry-pick three cards. Pick up about half the deck and pause for a moment with your cards above the rest of the pack. Now, if you wish you may put the cards back and separate the pack at a spot higher or lower – or you can just leave things as they are.”* No matter what she decides to do, have her complete the cut. Say, *“Please deal three cards into a row in front of you.”* Touch the back of the first card and say the word, *“Color.”* Touch the third card and say, *“Suit.”* Finally, touch the second card and say, *“Value. If this works, those three cards will be a glimpse into your cherry-picking future.”*

Believe it or not, the Si Stebbins arrangement of the pack is already at work here. In order, those three tabled cards represent the color, the value, and the suit of the twelfth card from the top of the deck. For the sake of instruction, assume the tabled cards are the Ace of Hearts, the Four of Spades, and the Seven of Diamonds respectively. This means the twelfth card from the top of the deck is the Four of Diamonds. You will now force this target card upon your guest. To use a sleight-of-hand method would conflict with the plot, so a more “hands-off, guest-involved” method will be employed.

Hold the pack face down and say, *“In a moment, you are going to give yourself plenty of cherries to pick from. Cherries come in bunches so this is what you’ll do.”* Spread two cards together into your right hand and then drop that packet face down on the table. Now repeat this action with only one card but drop this card next to the first pair. Repeat this with another two card packet. Again, drop this packet somewhere else on the table. Now drop a three-card packet to the table. Finally, drop another two-card packet. The pattern is 2-1-2-3-2. Your demonstration looks random, but it leaves ten cards in five groups around the table. Collect the packets and add them to the bottom of the deck. Your target card is now second from the top. Keeping track of it now is as easy as, well... picking fruit off a tree.

the art and craft of conjuring cont'd

Hand the deck to your guest and say, *“You will decide on three things: the number of cards in each packet, the number of packets on the table, and where the packets go on the table. Scatter them where you like. Just one, two, or three cards in each packet will be enough.”* As she drops her packets of one, two, or three cards around the table it is easy to keep track of the target card. Depending on her decisions, the target card will either be the second card of the first packet or the top card of the second packet. As soon as a couple of piles are on the table, say, *“You do not have to use all the cards. Feel free to stop whenever you wish.”* Your guest will usually stop after making six or seven piles. The balance of the deck is placed aside.

From here, the target card will be singled out by using a blend of two methods: the PATEO Force and equivoque. PATEO stands for “Pick Any Two, Eliminate One.” The force was created by Roy Baker and was first published in 1968.

Say, *“You have put a random number of cards in a random number of piles in random places all over the table. We need to whittle these down to just one. Remember the story about two children who each wanted a slice of pie? To keep it fair, the mother said, ‘One of you cuts the pie; the other one chooses the piece.’ The same thing will happen here. One of us points to any two piles but the other person chooses which one to eliminate. We’ll keep going back and forth until there is only one pile left.”*

The PATEO Force works because you always point to piles that are not the target one, so it does not matter which one she eliminates. However, if one of the piles she chooses *is* the target one, then just remove the other pile from the table. Eventually, two piles will remain and one will be the target packet. Say, *“Please touch one of the piles.”* If she touches the target pile, you pick up the other one and discard it. If she touches the other pile, instruct her to discard it with the others. Either way, the target pile is the only one left.

Remember your astute tracking observations earlier? Your target card is either on top or is the second card in this remaining pile. To force the target card, you will use the process-of-elimination method called equivoque. Let us assume there are three cards and the middle one is the target card. Spread the three cards out side-by-side and say, *“You’re almost there. Please push any card toward me.”* If she pushes the target card, then discard the other two; you are done. However, if she pushes any of the others, then discard it. You now have two cards. Immediately say, *“Please pick up either one.”* If she picks up the target card, then you discard the other one. If she picks up the other card, then instruct her to discard it onto the deck. Either way, the target card remains and the selection process appeared fair and innocent.

It’s time for some acting. Put a look of concern upon your face. Say, *“Now that you have cherry-picked this one card out from the others, I am nervous. There is a lot riding on your decisions. Everything about this one card [point to the target card] hinges on the three cards you put aside at the beginning.”* Touch the back of the first card again and say, *“Earlier, we named this card ‘Color.’”* Turn the card over so everyone can see it is the Ace of Hearts. Say, *“The color is red – but there is a fifty-percent chance this prediction is wrong. Would you peek at your cherry-picked card and just tell us if it is red or black?”* She does so and confirms her card is red. Act relieved for a moment and say, *“So far, so good.”*

Touch the back of the third card and say, *“I believe we named this one ‘Suit.’ I’m nervous again because there is a seventy-five percent chance this prediction has the wrong suit and if it does,*

we have to start all over again.” Turn the card over to show the Seven of Diamonds. Say, “The suit is Diamonds. Is your card a Diamond by chance?” She will confirm it is. Again, act relieved for a moment and then let the nervousness return.

Touch the second card and say, “We named this one ‘Value.’ This is it, everybody; no turning back now. There is a ninety-percent chance this prediction is completely wrong. Think about it. What if you stopped making piles too soon? There is a strong possibility the right card never made it onto the table in the first place. With that in mind, let everyone see the result of your cherry-picking first.” Your guest turns over her card. Say, “The Four of Diamonds! Okay, for this to be successful this last prediction has to be a Four, too. If the value is off even by one number, this whole adventure has been nothing but an exercise in futility.”

Turn over the remaining prediction card. The values match. If your guest is to believe that you were nervous earlier, then she must believe you are happy for her success now. So act like it and say, “Well, look at that; against all odds, you cherry-picked nothing but the best!”

Conflict, tension, and surprise have been achieved using simple methods and a bit of choreography. This is good theater. ♦

Cherry-Picking copyright 2015 by Mick Ayres.



THE UNBELIEVABLY USEFUL COMEDY PROP

WHEN YOU ABSOLUTELY, POSITIVELY NEED TO PUT A RUBBER THING ON THE END OF A STICK.

A POWERFUL MAGIC TOOL DISGUISED AS A GAG!

BY MICHAEL CLOSE

The Unbelievably Useful Comedy Prop

This has proven to be useful in both my close-up and stand-up performances. It is not only a laugh-getting device, it also functions as an applause cue, a running gag, and an extremely subtle way to unload a “dirty” hand without obviously going to a pocket or using a device such as a Topit.

\$20.00 USD + Shipping (Ships from Canada)

Package includes:

- Three (3) little hands
- Some suggestions on how to use it in your performances.

(Pencil or dowel not included.)

BUY NOW

TECH TRICKS BY BRUCE KALVER

Bruce Kalver is a professional magician and tech guru. Bruce is a past president of the S.A.M. and a frequent performer at The Magic Castle in Hollywood.



NO NEED TO SHOUT

Ethel Merman never needed a microphone. Eddie Cantor didn't need one, either. In fact, Broadway theaters were never wired for sound until the 1960s. Today, it seems every venue needs a sound system. Why? Audiences were quieter back then? More polite? People were trained to project their voice?

I've recommended a few sound systems. Although I have at least three or four systems for various venues, recently I found a really nice one that

you may want to try. It's called the **WinBridge Wireless Voice Amplifier**.

This nine-inch-by-nine-inch box does a lot! First, it is a wireless speaker system with a headset microphone. It is also a Bluetooth receiver, so you can wirelessly play music to it from your smartphone. With a five to six hour rechargeable battery, it will easily cover a classroom or 25,000 square foot lecture hall that holds a hundred people.

The speaker also has a SD card slot so you can record your show. There is even a button to give your voice an echo. The speaker weighs about three-and-a-half pounds.

Check out the **WinBridge Wireless Voice Amplifier** at www.amazon.com. It sells for around \$125.



I'LL BE INSIDE



I'm a little late in finding out about this magic effect, and I regret missing all the time I could have been fooling people with it. Luke Dancy, the person behind the All Things Magic group online, told me about an effect he created a few years ago in which a coin goes inside a smartphone. I know what you are thinking. It's not that app. In fact, it's not an app at all. In fact you don't do it on your phone but rather put the coin inside a spectator's phone!

The trick is called **Capture** and it is a cool looking illusion. Borrow a phone and a coin. Drop the coin on the screen and slide it around. Press on the coin with your palm and it goes into the screen. Slide it around and show that it is truly inside. Tilt the phone and shake the coin out into the spectator's hand. Immediately give everything back to be examined. It's really clean.

So if it isn't an app, it must involve a gimmick. Yes, it does. Nothing here is complicated; in fact, Luke tells you how to make your own gimmick should you ever misplace it. The video instructions

are complete, actually sometime too complete. There are a couple of other routines that they include; I feel the price is worth the effect. You can find **Capture** by Luke Dancy at www.allthingsmagic.com.

I'M ALL THUMBS

Okay 3D-printer owners, I found a useful file to print out. It may seem simplistic, but when I tried it out, it turned out to be very useful. It's a thumb tip holder to help you gain instant access to your gimmick. The holder can be pinned anywhere on you. It's perfect for a D'Lite gimmick; give this a try. Go to www.thingiverse.com and search for the **Magic TT Device**. The file is free.



WHICH HAND?



We all know the game of hiding something in one hand and asking someone else to guess which hand the object is in. Magicians have used highly electronic or sometimes dangerous gimmicks to figure it out. Well, Plainsight Magic has come up with a clever idea to accomplish this. Meet **Echolocation**.

Hand someone one of your AirPods and have them hide it in one of their hands. As the folks at Plainsight Magic state, "The app harnesses the high end technology inside of the AirPods to secretly cue the magician when it is in motion. Keep your iPhone in your pocket to feel a vibration, or peek the information in plain sight."

They've come up with a great ending by opening your Note app and showing them a prediction you made perfectly predicting the outcome every time. This works from thirty to sixty feet away. The app functions with AirPods Pro, AirPods (3rd Generation), and beyond.

The **Echolocation** app is available on the iPhone App Store and is free. ♦

MAGIC LESSONS

Want to save on your magic education? Start with four or more lessons and take advantage of our Buy More, Save More offer.

WITH MICHAEL CLOSE

"Without a doubt the best investment I have ever made when it comes to my magic."
—Sebastian B.

Click for more information

