

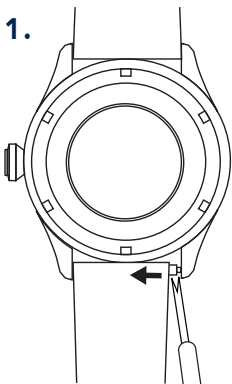

SPINNAKER

A. CHANGING STRAPS WITH A SPRING BAR TOOL



Back of the strap

Insert the *fork (tool) in between the strap and the watch lug. Gently apply pressure inwards to push the spring bar away from the lug

*You may purchase the spring bar tool from any local watch parts stores.

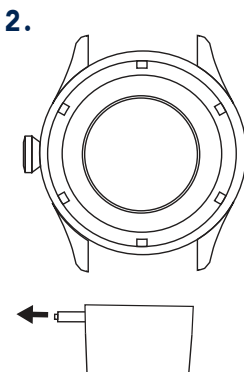

Pull the spring bar out of the strap.

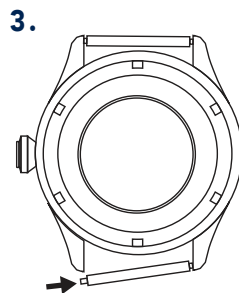

Insert the spring bar back in between the watch lug by gently pushing the side of the spring in. You may use the extra spring bars provided or simply purchase additional spring bars from any local watch parts store.



SPINNAKER

B. CHANGING STRAPS WITH QUICK-RELEASE SPRING BAR

Removing The Strap

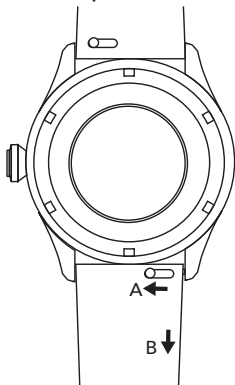

Back of the strap

Using your fingernail, push the peg to the left side to release the strap from the watch (A) and gently pull the strap away (B).

Putting The Strap On

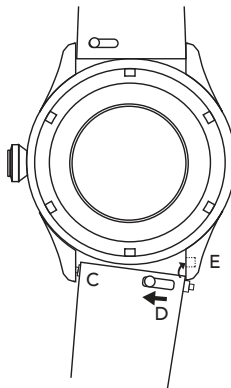

Position the pin that is opposite to the peg into its relevant hole on the watch's lug (C). Once in place, pull the peg to the left side (D) and align the remaining pin with its hole in the lug (E).

Release Peg To Secure

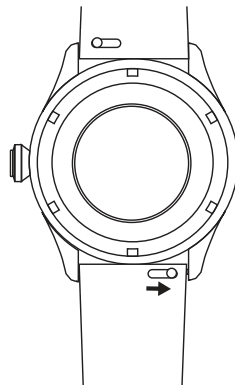

Release the peg to secure the strap into the lugs. You may need to wriggle the strap until the pin falls into place. When it does, you should hear a 'clicking' sound.



SPINNAKER

C. CHANGING STRAPS WITH WATCH PIN

1.

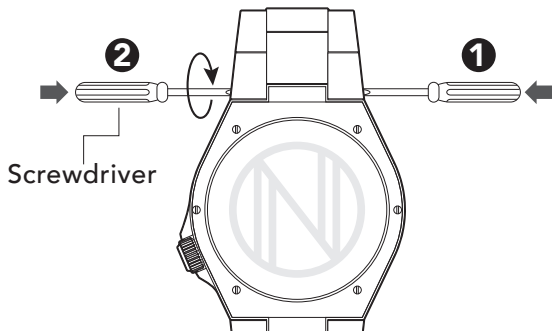

2.

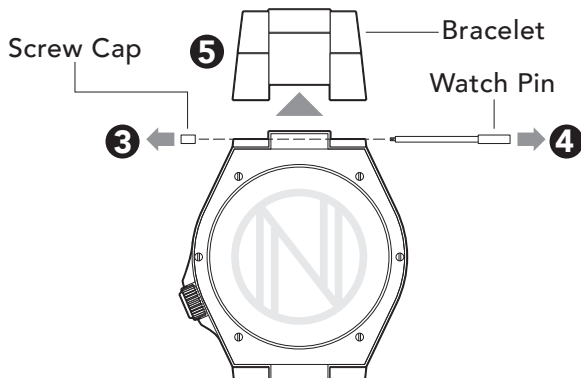



SPINNAKER

3.

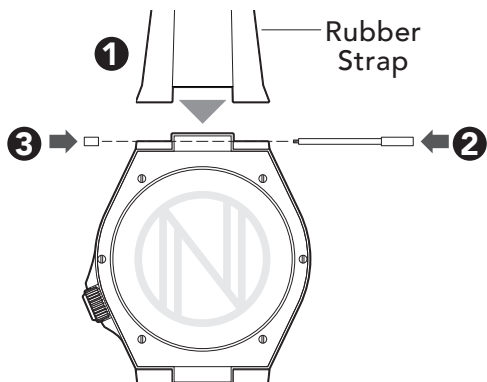

5.

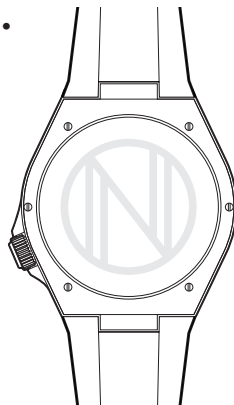

4.

