

2500 CABINET SYSTEM

OWNERS'S MANUAL

**USE WITH WHISPERKOOL
WINE CABINETS ONLY**

***Whisper* **KOOL**[®]**
The Future of KOOL

We manufacture, test and certify 100% of our wine cooling units in the USA. By sourcing the best components and closely controlling our manufacturing processes, we can assure the highest-quality, lowest defect manufacturing rates in the industry.

Copyright © 2022. WhisperKOOL. All rights reserved.

WhisperKOOL copyrights this manual, the product design, and the design concepts, with all rights reserved. Your rights with regard to the hardware and manual are subject to the restrictions and limitations imposed by the copyright laws of the USA. Under copyright laws, this manual may not be copied, reproduced, translated, transmitted, or reduced to any printed or electronic medium or to any machine-readable form, for any purpose, in whole or in part, without the written consent of WhisperKOOL.

Every effort has been made to ensure that the information in this manual is accurate. WhisperKOOL is not responsible for printing or clerical errors.

WhisperKOOL reserves the right to make corrections or improvements to the information provided and to the related hardware at any time, without notice.

Vinothèque and WhisperKOOL are registered trademarks, and ECE is a trademark of WhisperKOOL. All rights reserved. Mention of third-party products is for informational purposes only and constitutes neither an endorsement nor a recommendation. WhisperKOOL assumes no liability with regard to the performance or use of these products.

TABLE OF CONTENTS

WK 2500 Quick Reference Guide	2
WK 2500 Accessory Kit	2
Note to Customer	3
About the WhisperKOOL 2500	3
Liquid Measuring Thermometer	4
System Operation	5
Controller Operation.....	7
Testing the Refrigeration Unit	10
Cool Down Period	10
Normal Operation and Maintenance	11
Troubleshooting.....	12
Installation Terms and Conditions	13
Technical Assistance	15

WHISPERKOOL 2500 QUICK REFERENCE GUIDE

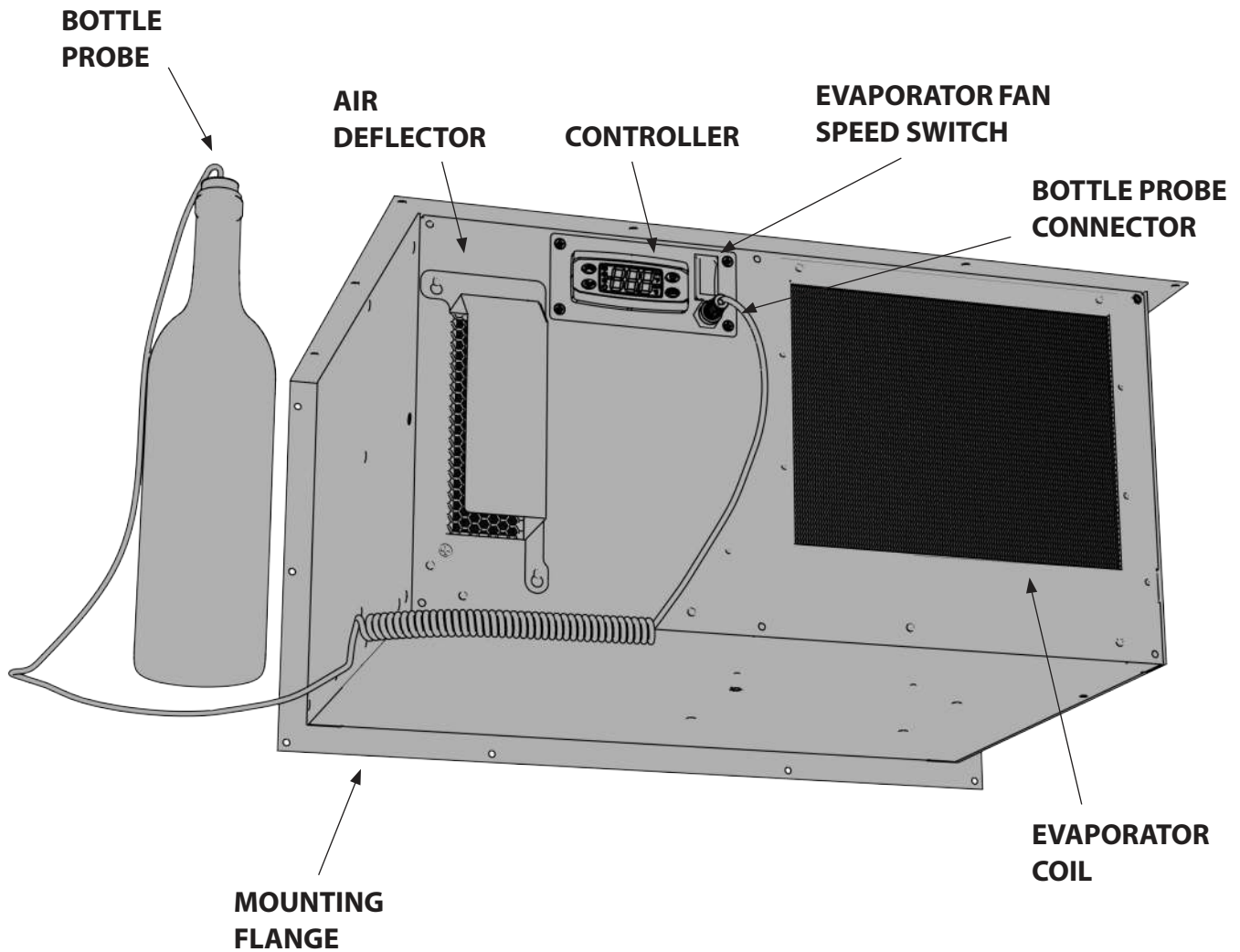

ACCESSORY KIT

WK 2500

Contents:

- (18) 1/4" x 3/8" pan-head screws
- (1) 1/8" x 8-ft piece of foam tape

NOTE TO CUSTOMER

Thank you for purchasing a WhisperKOOL wine cabinet unit. Our main goals are customer satisfaction and providing the best wine storage solutions on the market. If you have any questions or comments, please feel free to contact us at info@whisperkool.com.

It is mandatory that you DO NOT plug in or start your new WhisperKOOL wine cabinet unit for 24 hours after its delivery.

Units are sometimes placed on their side during shipping, which might cause compressor oil to escape the reservoir. Starting the unit before the oil has had a chance to settle again can cause damage to the compressor and negatively affect cooling.

A dedicated 20 amp circuit is highly recommended for optimum operation. Tripped breakers and deficient performance may occur if other devices are pulling power from the same circuit. Do not use a Ground Fault Interrupter (GFI) with this product. The cooling unit will draw more amperage than the GFI will allow.



It is recommended that you plug your unit into a surge protector or power conditioner. Just like with any sensitive electrical equipment, the unit's circuitry may be damaged by power surges and spikes — which are not covered by the warranty.

ABOUT THE WHISPERKOOL 2500

The system was designed to operate in controlled environments with temperatures ranging between 60°-85°F. This is ideal for cabinets that will be inside a home or temperature controlled environment.

LIQUID MEASURING THERMOMETER

By measuring the temperature of the liquid, the temperature reading will be consistent and the unit will only run when it needs to.

To Install the Thermostat:

1. Fill an empty wine bottle to its neck with room temperature water.
2. Press bottle probe securely into bottle.
3. Place the bottle with probe into a level rack space. Avoid pulling too much on the probe cord as it may become disconnected, which would lead to inaccurate temperature readings.

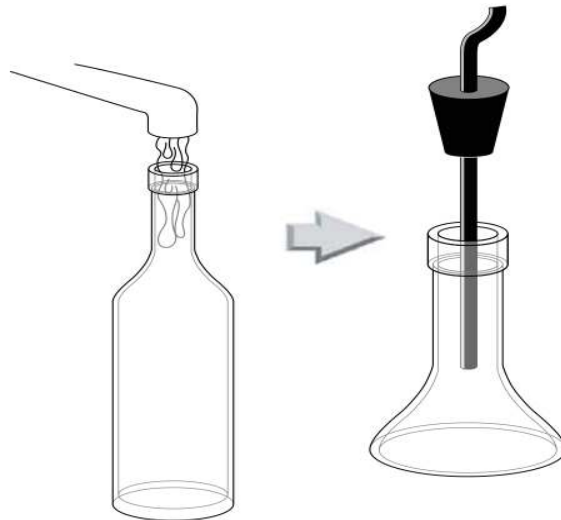

The WhisperKOOL system is based on the temperature of the wine (It is ideal to place the probed bottle **midway in the racking**, so that it is not near cold supply air). Do not be misled by ambient temperatures that are read from the outside of the cabinet. The air temperature in the cabinet will be cooler than the liquid temperature of the wine while it's coming to optimum balanced temperature.



WK 2500 WIRING DIAGRAM

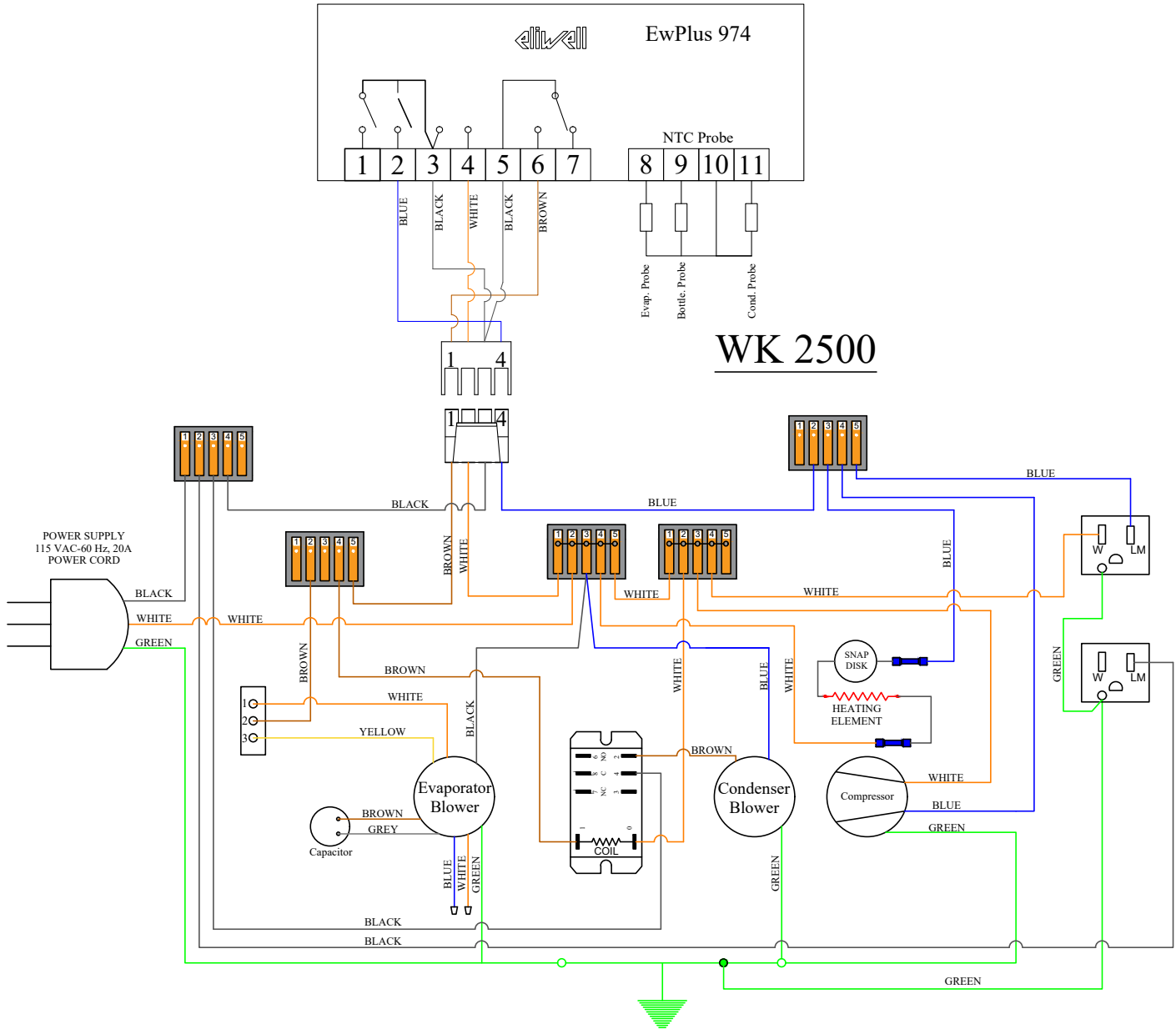

SYSTEM OPERATION (WHISPERKOOL 2500)

Initial Startup

When power is applied to the unit, the control will briefly display all symbols, and the snowflake symbol will be displayed (if unit is calling for cooling). There may be a brief delay (up to 60 sec.) before the evaporator fan turns on. When the evaporator fan is activated, the fan symbol will display.

Setpoint

The setpoint is preset at the factory (WhisperKOOL) to 55°F. It can be adjusted by the customer between 50°F and 70°F (in 1°F increments).

Cooling Operation

Cooling is activated once the bottle probe senses a temperature that is 1°F greater than the setpoint. The controller then energizes the compressor relay which activates the compressor. The evaporator and condenser fans operate with the compressor. The unit provides cooling until the bottle probe senses that the setpoint has been reached. At this point the compressor relay is de-energized, which stops the compressor. The evaporator and condenser fans will continue to run for one minute to reintroduce any moisture from the evaporator coil and reduce the head pressure.

Humidity Features

The Fdc parameter can be increased to allow the evaporator and condenser fans to run for a longer period of time after the compressor turns off, allowing more moisture to be reintroduced into the wine cellar.

Anti-Short Cycle

The Anti-Short Cycle ensures that the compressor will remain off for a period of three minutes after the unit has reached the setpoint to allow the pressure in the refrigeration unit to equalize prior to starting the compressor.

Anti-Frost Cycle (defrost)

When the evaporator probe senses a temperature of 26°F for five minutes, the unit will enter an Anti-Frost Cycle. This will shut down the compressor and allow the evaporator and condenser fans to run to evaporate any frost accumulation on the coil. The compressor will remain off until the evaporator coil reaches 40°F, or for a maximum of ten minutes. The unit will then return to normal operation.

If the evaporator is not above 26°F after the Anti-Frost Cycle has ended, the red error light will display in the upper right corner. The alarm "Ad3" will be recorded in the alarm folder, indicating that the Anti-Frost Cycle timed out. The unit will run for five minutes and then enter another Anti-Frost Cycle. This sequence will continue until the evaporator temperature rises above 26°F.

cycle is less than five minutes, the controller will prevent the compressor from starting until five additional minutes have elapsed. This is to prevent short cycling of the compressor.

Holding down the UP ARROW button for approximately five seconds manually starts the Anti-Frost Cycle, but only if the evaporator is below 40°F (defrost end temperature). If the evaporator is above 40°F, the display will blink three times and continue normal operation.

Bottle Probe Failure Protection

In the event that a bottle probe should fail, the APST (Advance Product Safety Technology) will automatically transition the refrigeration compressor cycles to a pre-determined time series (40 minutes on and 10 minutes off), which will ensure that the product is kept within a safe temperature range. P1 will be displayed on the screen until the probe issue is rectified.

Alarms

See "Alarm Codes" in the Controller Functions chart.

ECM Condenser Blower Operation

The condenser blower comes equipped with a temperature sensor which monitors exhaust air temperatures and adjusts the speed of the blower to provide the ideal airflow needed to dissipate excess heat. Condenser fan speed will vary during operation based on the exhaust environment temperatures.

"Def" will be displayed during the Anti-Frost Cycle. If the

SYSTEM OPERATION (WHISPERKOOL 2500) CONT.

Ambient Temperature

The ambient temperature surrounding the cabinet has a direct effect on the cooling unit's ability to cool the cabinet. The ideal temperature range for which the cabinet will be installed is between 60-85°F. Ambient temperatures above 85°F will decrease the cooling capacity of the unit. Make sure the temperature of the room in which the cabinet will be placed is maintained within the recommended range.

To ensure a consistent temperature, make sure the room temperature does not dip below 55°F.

Ventilation

The cabinet must have adequate ventilation to allow the exhaust side of the cooling unit to operate correctly. As the unit cools on the inside, condensing refrigerant creates heat, which will need to dissipate away from the unit on the outside. Some units have an exhaust fan mounted on top of the cabinet, which forces air away from the unit vertically. In order to avoid disrupting the ventilation, **do not place anything on top of the cabinet.**

WhisperKOOL 2500 Cooling System:

- If your cabinet is not equipped with a front vent, the unit must be placed in an open room.
- Do not install in a cabinet.
- The rear of the unit should be placed about 2" from the wall.
- There should be about 12" of clearance above the top of the unit and 6" of free space on each side. This will assure proper dissipation of heat and sustained cooling of your wines.

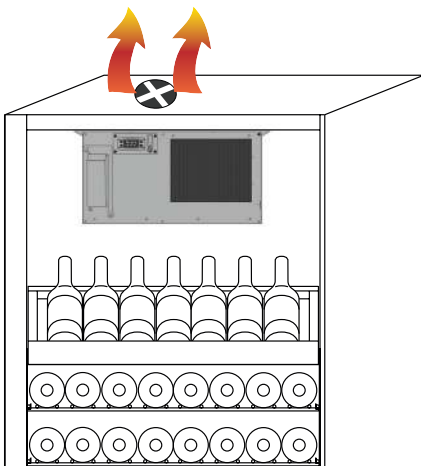

Top venting (standard).

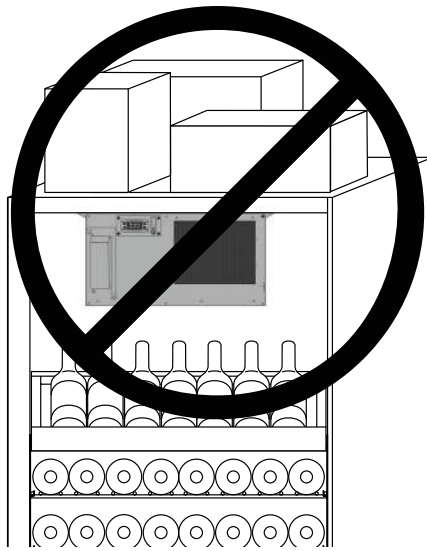

Do not place anything on top of the cabinet.

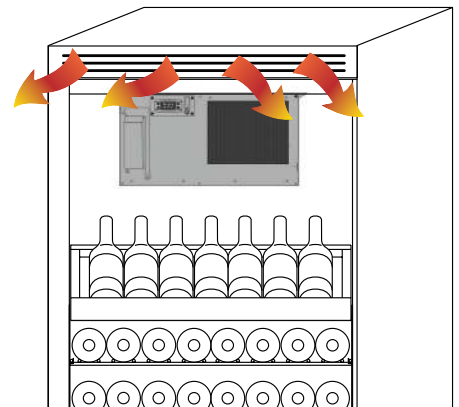







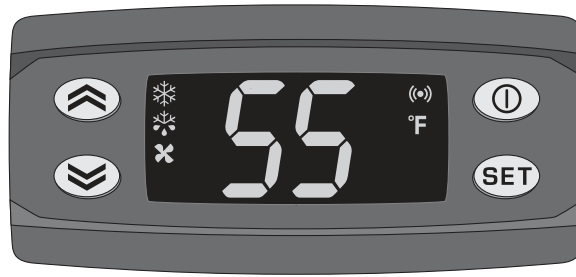

Front venting unit.

WhisperKOOL™

CONTROLLER FUNCTIONS



Button/Symbol	Normal Functions
ON/OFF 	<ul style="list-style-type: none"> Press and hold the ON/OFF button for approximately 3 seconds to turn the unit on or off. Note: This does not disconnect power from the unit. In order for the power to be shut off from the unit, the power cord must be unplugged from the power outlet. This button also serves as an escape button.
UP/ DOWN  	<ul style="list-style-type: none"> Use these buttons to scroll up or down a menu. Press and hold the UP ARROW button for approximately five seconds to manually start the Anti-Frost Cycle. The Anti-Frost Cycle will begin, but only if the evaporator is below 40°F. If the evaporator is above 40°F, the display will blink three times, signalling that an Anti-Frost Cycle is not needed, and the unit will continue normal operation.
SET 	<p>Changing the Set Point</p> <ul style="list-style-type: none"> Press and Release the set button. While "SET" is displayed, press and release the set button again. While the current temperature setting is displayed, press the up or down arrows to change set point. When the display shows the desired temperature setting, press and release the set button again. <p>Accessing Alarm Codes</p> <ul style="list-style-type: none"> Press and Release the set button. While "AL" is displayed, press and release the set button.
SNOWFLAKE 	<p>Steadily Illuminated: The unit is in cooling mode and the compressor is running. Blinking: The unit is calling for cooling, but must wait five minutes before restarting the compressor. This five-minute delay serves as an anti-short cycle for the compressors protection.</p>
DRIPPING SNOWFLAKE 	<p>The unit is running an Anti-Frost Cycle. The evaporator and condenser fans are running to evaporate any frost which may have formed on the evaporator coil.</p>
FAN 	<p>The evaporator and condenser fans are on.</p>
ALARM 	<p>The alarm symbol is shown and an audible buzzer will sound when the unit encounters an issue that needs attention. The displayed alarm codes are explained on the next page. To silence the buzzer, press any button. The alarm code will remain displayed until corrected.</p>

ALARM CODES

Message	Cause	Solution
"E1"	Bottle probe is unplugged	Attach bottle probe to unit
	Faulty bottle probe connection	1. Check bottle probe attachment at circular connector 2. Check bottle probe connection at the back of controller
	Defective bottle probe	Replace the bottle probe
"E2"	Faulty evaporator probe connection	Check evaporator probe connection at the back of controller
	Defective evaporator probe	Replace the evaporator probe
"E3"	Faulty condenser probe connection	Check the condenser probe connection at the back of the controller
	Defective condenser probe	Replace the condenser probe
"AH1"	The bottle probe is sensing a temperature that is 4° above the setpoint	1. Allow time for the wine to reach the desired temperature 2. Make sure all windows and doors are closed and have a proper seal 3. Follow the procedures in the pre-installation instructions to test the unit for proper cooling
"AL1"	The bottle probe is sensing a temperature that is 4° below the setpoint	1. Make sure unit is not in cooling mode (the snowflake symbol will not be lit) 2. Add heat to the room until the wine reaches the desired temperature
"COH"	The condenser coil temperature is above 125°F	1. Check the condenser coil and clean if necessary 2. Make sure the intake air does not exceed 85°F 3. Make sure both condenser fans are working properly
"Ad3"	Anti-Frost Cycle ended on time-out	1. Check the evaporator coil for ice buildup; unplug the unit and allow the coil to thaw before restarting 2. Make sure the room the intake air is not less than 60°F 3. If the unit continues to go into continuous Anti-Frost Cycles (every 5 minutes), call Customer Service for more troubleshooting information

CPSM (Customer Preference Selection Mode)

Press and hold the SET button for approximately 5 seconds to enter the CPSM menu. "Fdc" will be displayed on the screen. Use the down arrow to access the following parameters.

Fdc <i>Humidity Management/Enhancement</i>	This parameter is preset to one (1) minute at the factory. This amount of time should provide adequate relative humidity for the cellar. An increase in this parameter will keep the fan running longer after the compressor has turned off, reintroducing some of the moisture which was extracted from the wine cellar during the cooling cycle back into the cellar. (The WhisperKOOL unit, however, cannot increase the humidity of the cellar.) This parameter should not be adjusted below 1. Adjustments should be made in increments of 5, with a maximum of 15 and a minimum of 1. After making any adjustment to Humidity Enhancement, you should wait a minimum of three days before making any additional adjustments. This will allow the cellar sufficient time to acclimate to the new setting.
PA2	There are no adjustable settings in this parameter.
tab	There are no adjustable settings in this parameter.
Rel	There are no adjustable settings in this parameter.
loc	Change this parameter from "n" to "y" to lock the keyboard from changes to the setpoint.
ddd	Select one of these numbers to display your preference: 0 = Setpoint 1 = Bottle Probe Temperature 2 = Evaporator Probe Temperature 3 = Condenser Probe Temperature
"CA1"	Use this parameter to calibrate the bottle probe to a known temperature. This parameter can be adjusted between -12°F and 12°F. Example: Bottle temperature reading = 58°F Known temperature reading = 55°F CA1 parameter setting to match known temperature = -3

TESTING THE REFRIGERATION UNIT

Remember, do not start or plug in your unit for 24 hours after delivery. Many units are placed on their sides during shipping, which may allow compressor oil to escape their reservoirs. Premature starting before the oil has had a chance to resettle can cause damage to the compressor and result in a lack of cooling.

Before you fill the cabinet with wine, you'll want to check the operation of the unit. All cabinets successfully pass quality control at the WhisperKOOL facility.

Periodically a unit's cooling system is damaged in transport. Simply turn the unit on for about one hour and confirm that the temperature is cooling down. This will prevent the inconvenience of stocking and restocking a damaged unit.

If the unit is not working correctly, contact WhisperKOOL's Customer Service Department at info@whisperkool.com. We will work with you to diagnose the problem and promptly resolve it.

LOADING BOTTLES AND COOL DOWN PERIOD

Loading Bottles

The cabinet may settle slightly based on the weight of all the bottles. It is best to spread the loading of bottles evenly throughout the cabinet, starting on the bottom first. This will prevent the unit from shifting and potentially knocking the doors out of alignment.

Cool Down Period

When the time comes for you to begin loading wine bottles into your unit, there are some considerations to be made. The cabinet should be loaded in stages. We recommend 1/4 of the cabinet per day. This will allow the unit to achieve more rapid temperature stabilization. Loading all of the wine at once might overwhelm the cooling system.

During the cool down period, the system will run constantly, depending on the size of the collection. Slow cooling maintains correct humidity within the cabinet.

NORMAL OPERATION MAINTENANCE

The cooling unit will cycle on and off as needed once the temperature has stabilized and the initial “cool-down” has been completed.

— **Thermostat:** Should be 55°F or desired wine temperature.

Maintenance

WhisperKOOL recommends cleaning the condenser filter every three months. WhisperKOOL recommends vacuuming of the condenser fins located in the rear of the cabinet every three months. A partially obstructed condenser dramatically reduces the efficiency of the cooling unit.

Monthly:

- Check filters
- Check for unusual noise or vibration

Quarterly:

- Clean filters
 - o Remove the filter covering the coil
 - o Wash with warm water
 - o Dry off filter by shaking off excess water
 - o Gently vacuum across the condenser fins behind the filter
 - o Gently vacuum the evaporator coil

TROUBLESHOOTING

Problem	Likely Cause	Solution
System will not start	Tripping circuit breaker	Reset breaker, verify dedicated 20 amp outlet and not on ground fault interrupter
	Temperature setting is wrong	Adjust your set temperature
	Wine probe disconnected	Assure probe line is in a bottle of water and is not stretched. Check connections.
Runs constantly	Thermostat setting	It may be set too cool — raise the set temperature
	Cabinet recently loaded with wine	Allow time. It may take several weeks to reach optimal storage temperature.
	Ambient room temperature is too warm	Lower the temperature in the room.
	Inadequate ventilation	Assure proper space above, behind and on the side of the unit. Do not set anything on top.
	Door gasket not sealing properly	See cabinet owner's manual
Not cooling	Thermostat setting	May be set too warm - lower the set temperature
	Thermostat not operating correctly	Test unit with bypass plug. Contact Customer Service
	Low on refrigerant or Freon	Unit may need service. Contact Customer Service
	Inadequate ventilation	Assure proper space above, behind and on the side of the unit. Do not set anything on top
Icing up	Unit running constantly	See above section on units running constantly
	Low on refrigerant or Freon	Unit may need service. Contact Customer Service
Clicking noise during start-up	Outlet power	Assure 15 amp outlet and not on a GFI

WhisperKOOL customer service: 1-800-343-9463
8 a.m. to 4 p.m. PST, Monday through Friday
support@whisperkool.com

INSTALLATION TERMS AND CONDITIONS WHISPERKOOL COOLING SYSTEM

WHISPERKOOL PRODUCT BASE TERMS

WhisperKOOL Corporation ("WhisperKOOL") is in the business of manufacturing and selling wine cabinets, cooling units and related goods; each such wine cabinet, cooling unit and related good is referred to herein as a "Product". As used herein, the term "WhisperKOOL" includes any Product sold under the names WhisperKOOL, Vinof, and CellarCool. "Purchaser" means the original purchaser of a WhisperKOOL Product. "End User" means the consumer who has installed and is actually using a WhisperKOOL Product. Every sale of a Product from WhisperKOOL to a Purchaser is made subject to these Terms and Conditions of Sale ("Terms and Conditions").

Product prices are specified in the WhisperKOOL published price list that is current at the time WhisperKOOL receives Purchaser's particular order. Prices are subject to change at any time prior to WhisperKOOL's acceptance of Purchaser's particular order. No contract of sale exists until WhisperKOOL has accepted Purchaser's order and provided Purchaser with a written acknowledgment of Purchaser's order. Prices are exclusive of, and Purchaser shall pay, all taxes, duties, levies or fees imposed on WhisperKOOL or Purchaser by any taxing authority related to Purchaser's order. Payment for a WhisperKOOL Product must be made in lawful money of the United States of America in immediately available funds. WhisperKOOL accepts all major credit cards. WhisperKOOL may change payment terms for unfilled orders if, in WhisperKOOL's reasonable opinion, Purchaser's financial condition, previous payment record or relationship with WhisperKOOL merits such change.

All Purchaser orders, whether written or verbal, are governed by these Terms and Conditions and are subject to acceptance by WhisperKOOL.

Any term or condition which may be included on any Purchaser's purchase order, or in any form of communication (whether verbal or in writing) from any Purchaser to WhisperKOOL, that is not identical with these Terms and Conditions, is hereby expressly objected to and rejected by WhisperKOOL, and shall NOT become a part of the contract of sale of any Product. WhisperKOOL's failure to object to any such conflicting term and/or condition of sale contained in any communication (including a purchase order) from a Purchaser shall not be considered as acceptance of such term and/or condition or as a waiver of these Terms and Conditions. The only language in which WhisperKOOL states these Terms and Conditions is English. WhisperKOOL reserves the right, in its sole discretion, to change these Terms and Conditions at any time, for any reason, without notice. WhisperKOOL shall not be liable to Purchaser for any delay of delivery of a Product caused by Force Majeure, or any other cause beyond WhisperKOOL's control.

2. WHISPERKOOL PRODUCT LIMITED WARRANTY

A. Two (2) Year Limited Warranty.

For the period of TWO (2) YEARS (the "Limited Warranty Period") from the date of original sale of a Product by WhisperKOOL, if a WhisperKOOL Product is found to be defective in material or workmanship after undergoing WhisperKOOL's customer service troubleshooting, then, subject to the WhisperKOOL Product Limited Warranty Limitations and Exclusions as well as the other Terms and Conditions stated herein, WhisperKOOL will do the following, as appropriate, for the end user ("End User") who has installed and is actually using the Product, with regard to LABOR, PARTS and FREIGHT:

1. **LABOR** - repair or replace (at WhisperKOOL's sole option) the Product at no charge to the End User; and
2. **PARTS** - supply, at no charge to the End User, new or rebuilt replacement parts for the Product in exchange for the return of defective parts; and
3. **FREIGHT** - cover normal ground freight charges for parts, and, in the event the Product is not repairable in the field, cover normal ground freight charges (within the continental United States) for the repair or replacement of the Product.

B. Five (5) Year Compressor Limited Warranty.

The two (2) year limited warranty period stated in Section 2(a) above is extended for an additional three (3) year period with regard to a WhisperKOOL Product's compressor only. Labor, freight and parts ancillary to the compressor remain subject to the two (2) year limited warranty.

C. Product Warranty Limitations and Exclusions.

1. This limited warranty does not cover cosmetic damage caused during installation, damage due to acts of God, commercial use, accident, misuse, abuse, negligence, or modification to any part of the Product. Delivery and installation of the Product, any additional parts required, as well as removal of the Product if warranty work is required, are all at the sole cost, risk and obligation of the End User.
2. This limited warranty does not cover damage due to improper installation or operation or lack of proper maintenance of the Product, connection of the Product to improper voltage supply, or attempted repair of the Product by anyone other than a technician approved by WhisperKOOL to service the Product.
3. This limited warranty does not cover any Product sold "AS IS" or "WITH ALL FAULTS."
4. This limited warranty is valid only in the continental United States, Alaska and Hawaii. Sales elsewhere (including Puerto Rico) are excluded from this warranty.
5. Proof of purchase of the Product in the form of a bill of sale or receipted invoice, which is evidence that the Product is within the Limited Warranty Period, must be presented by the End User to WhisperKOOL in order to obtain limited warranty service.
6. This limited warranty is void if the factory applied serial number has been altered or removed from the Product.
7. Removing the rivets from the Product's unit housing without prior authorization from WhisperKOOL voids this limited warranty.
8. The End User must first contact WhisperKOOL Customer Service by telephone (at 1-800-343-9463) prior to attempting service on any Product still under the limited warranty, else the limited warranty is voided.
9. THE REPAIR OR REPLACEMENT OF THE PRODUCT AS PROVIDED UNDER THIS LIMITED WARRANTY IS THE EXCLUSIVE REMEDY OF YOU, THE END USER, AS WELL AS ANYONE ELSE IN THE CHAIN OF TITLE OF THE PRODUCT, DOES NOT START A NEW LIMITED WARRANTY TIME PERIOD, AND IS IN LIEU OF ALL OTHER WARRANTIES (EXPRESS OR IMPLIED) WITH REGARD TO THE PRODUCT. IN NO EVENT SHALL WHISPERKOOL BE LIABLE FOR INCIDENTAL, CONSEQUENTIAL, SPECIAL OR CONTINGENT DAMAGES FOR BREACH OF ANY EXPRESS OR IMPLIED WARRANTY ON THIS PRODUCT. THE IMPLIED WARRANTIES OF MERCHANTABILITY AND FITNESS FOR A PARTICULAR PURPOSE ARE HEREBY EXPRESSLY DISCLAIMED. Some states do not allow the exclusion or limitation of incidental or consequential damages, or allow limitations on how long an implied warranty lasts, so the above limitations or exclusions may not apply to you. This limited warranty gives you specific legal rights, and you may have other rights, which vary from state to state.
10. Failure of the End User to comply with all of the Product Installation Requirements, Maintenance Requirements and End User Requirements may, at WhisperKOOL's sole discretion, void this limited warranty.
11. No one has any authority to add to or vary the limited warranty on this Product.

3. PRODUCT INSTALLATION REQUIREMENTS

- a. Prior to installing a WhisperKOOL Product, the End User must read the WhisperKOOL Owner's Manual and thereafter the End User must follow the required installation, use and maintenance procedures set forth by WhisperKOOL in WhisperKOOL's Owner's Manual. The Owner's Manual is shipped with each Product and if another copy is needed, replacement copies can be downloaded from WhisperKOOL's website (www.whisperkool.com) or by contacting WhisperKOOL directly for a new copy of the Owner's Manual.
- b. It is highly recommended that the End User obtain the assistance of a wine storage professional.
- c. Failing to address all of the variables associated with proper installation will cause the Product to operate incorrectly and limit both the Product's ability to cool and the longevity of the Product itself.
- d. The limited warranty card should be completed and promptly returned by the End User to WhisperKOOL to ensure limited warranty registration and confirmation of date of purchase.
- e. The End User is responsible for all risks and costs of installation of the Product, including but not limited to all labor costs as well as cost of any additional parts required for the proper and complete installation of the Product. The End User is responsible for all risks and costs of removing the Product if limited warranty work is required.
- f. The Product cannot operate at its optimum capacity if airflow is constricted by ducting or venting the exhaust side of the Product into a location with inadequate ventilation.

4. MAINTENANCE REQUIREMENTS

It is the End User's responsibility to clean off any accumulated dust, lint, or other debris from the front and rear intake grills; failure to do this on a regular basis will restrict the airflow and may affect the Product's ability to function properly. Periodically cleaning the Product's vents will help assure maximum cooling efficiency. The drain tube must also be checked and kept clean and free of debris and mold to maintain proper performance.

Mold is a natural living organism in the environment. It exists in the air in the form of microscopic spores that move in and out of buildings through doors, windows, vents, HVAC systems and anywhere else that air enters. Once it is discovered, mold must be addressed quickly and appropriately. Delayed or improper treatment of mold issues can result in costly and reoccurring repairs. If the End User suspects a mold problem, it is always best to hire a qualified and experienced mold remediation specialist.

5. ADDITIONAL END USER RESPONSIBILITIES

The following items are not covered under any warranty and are the sole responsibility of the End User:

- a. End Users should satisfy themselves that the Product they are purchasing is suitable for their particular needs and requirements, and thus no responsibility will be placed with WhisperKOOL for the End User's decisions in this regard.
- b. It is the End User's responsibility to secure safe haven/storage for ANY AND ALL items that are being kept and stored in the End User's wine cellar, including any Product. WhisperKOOL takes no responsibility for the safety and preservation of the aforementioned items in the event that the environment becomes unsuitable to maintain a proper storage environment.

6. SALES AND USE TAX

WhisperKOOL only collects California sales tax for orders shipped within the State of California; WhisperKOOL does not collect sales tax for orders shipped to other states. However, the Purchaser and the End User may be liable to the taxing authority in their state for sales tax and/or use tax on the Product. The Purchaser and the End User should each check with their state's taxing authority for sales and use tax regulations.

7. CUSTOMER SERVICE AND TROUBLESHOOTING

WhisperKOOL's customer service department is available to answer and questions or inquiries for End Users regarding a WhisperKOOL

Product, as well as to assist in performing basic troubleshooting, Monday through Friday, from 8:00 a.m. to 4:00 p.m. PST, at telephone number 1-800-343-9463. WhisperKOOL Corporation is located at 1738 East Alpine Avenue, Stockton, California 95205.

8. ADDITIONAL TERMS AND CONDITIONS

- a. Return Policy. All return inquiries must be made within thirty (30) calendar days of the original purchase of a Product and are subject to a twenty five percent (25%) restocking fee. Shipping costs are not refundable and the Purchaser is responsible for all return shipping costs (including customs fees and duties, if applicable).
- b. WhisperKOOL retains a security interest in each Product until payment in full.
- c. Every provision of these Terms and Conditions shall be construed, to the extent possible, so as to be valid and enforceable. If any provision of these Terms and Conditions is held by a court of competent jurisdiction to be invalid, illegal or otherwise unenforceable, such provision will, to the extent so held, be deemed severed from the contract of sale between Purchaser and WhisperKOOL, and all of the other non-severed provisions will remain in full force and effect.
- d. The laws of the State of California (without regard for conflicts of law) shall govern the construction and enforcement of the these Terms and Conditions, except that these Terms and Conditions shall be interpreted as through drafted jointly by WhisperKOOL and Purchaser. Any dispute will be resolved by the courts in the County of San Joaquin, State of California, and all parties, WhisperKOOL, Purchaser and End User, hereby irrevocably submit to the personal jurisdiction of such courts for that purpose. No waiver by WhisperKOOL of any breach or default of the contract of sale (including these Terms and Conditions) concerning a Product will be deemed to be a waiver of any preceding or subsequent breach or default.

9. Questions or Additional Information

If you have any questions regarding these Terms and Conditions or wish to obtain additional information, contact us via phone at 1-800-343-9463 or please send a letter via U.S. Mail to:

WhisperKOOL
1738 E. Alpine Ave
Stockton, CA 95205
support@whisperkool.com

TECHNICAL ASSISTANCE

WhisperKOOL Customer Service is available Monday through Friday from 6:00 a.m. to 4:00 p.m. Pacific Standard Time.

The appointed customer service representative will be able to assist you with your questions and warranty information more effectively if you provide them with the following:

- The model and serial number of your WhisperKOOL unit.
- Location of the system and installation details, such as ventilation, construction of your wine cellar and room size.

Contact WhisperKOOL Customer Service

1738 E. Alpine Ave
Stockton, CA 95205
www.WhisperKOOL.com
E-mail: support@whisperkool.com
Fax: 209-466-4606

Model _____ Serial Number **A** _____

Installed by _____ Date _____

For WhisperKOOL 2500: Check Right side of unit on a silver sticker.

*Whisper***KOOL**[™]

WhisperKOOL
1738 E. Alpine Ave
Stockton, CA 95205
www.whisperkool.com