

## INSTRUCTION MANUAL ELECTRIC CHAIN HOIST SP



[www.Spanco.com](http://www.Spanco.com)



# Table of contents

Spare parts / Ordering spare parts .....	4
<b>0 General Information .....</b>	<b>5</b>
0.1 General safety instructions .....	5
0.1.1 Safety and hazard information .....	5
0.2 General safety regulations and organizational measures .....	5
0.2.1 Warning markings / Legends / Warning plates .....	5
0.3 Particular safety instructions/Transport and assembly: .....	5
0.4 Instructions for hazard protection .....	6
0.4.1 Hazards - Mechanical .....	6
0.4.2 Hazards - Electrical .....	7
0.4.3 Sound pressure level .....	7
0.5 Periodic checks .....	8
0.5.1 Warranty .....	8
0.6 Appropriate use .....	8
0.6.1 Use of the instruction manual .....	9
<b>1 Description .....</b>	<b>9</b>
1.1 General description .....	11
1.2 Emergency stop .....	12
<b>2 Start-up .....</b>	<b>12</b>
2.1 Transport and assembly .....	12
2.2 Connections .....	12
2.2.1 Electrical connections .....	12
2.2.2 Load chain .....	14
2.2.3 Limit switch .....	16
2.2.4 Chain container .....	16
<b>3 Care and Maintenance .....</b>	<b>17</b>
3.1 General guidelines for maintenance and repair .....	17
3.2 Care and maintenance .....	18
3.2.1 Care overview .....	18
3.2.2 Maintenance overview .....	18
3.2.3 Brake system .....	18
3.2.4 Load chain .....	19
3.2.5 Limit stop .....	19
3.2.6 Transmission .....	19
3.2.7 Slipping clutch .....	20
3.2.8 Suspension parts .....	20
<b>4 Measures for Achieving Safe Operating Periods .....</b>	<b>20</b>
4.1 Determining the actual operating time .....	21
4.2 General overhaul .....	21
4.3 Disposal .....	22
<b>5 Annex .....</b>	<b>22</b>
5.1 Technical data (Metric) .....	22
5.1 Technical data (Imperial) .....	23
5.2 Electrical parameters .....	24
5.3 Warranty .....	26

# Spare parts / Ordering spare parts

The correct order numbers for original spare parts can be obtained from the corresponding spare parts list. Please ensure that you have the following data on your electric chain hoist to hand. This will enable the correct spare parts to be supplied without delay.

Electric chain hoist type: \_\_\_\_\_

Serial number: \_\_\_\_\_

Year of manufacture: \_\_\_\_\_

Load capacity: \_\_\_\_\_

Original spare parts for the electric chain hoists can be acquired from the following addresses:

\_\_\_\_\_  
PtP Spanco, Inc.  
604 Hemlock Rd  
Morgantown, PA. 19543  
800-869-2080  
www.spanco.com

**Resellers / Agent** \_\_\_\_\_

\_\_\_\_\_

\_\_\_\_\_

\_\_\_\_\_

\_\_\_\_\_

\_\_\_\_\_

\_\_\_\_\_

\_\_\_\_\_

# 0 General information

## 0.1 General safety instructions

### 0.1.1 Safety and hazard information

The following symbols and terms are used in this instruction manual for safety and hazard instructions:



**WARNING !**

Non-compliance, either in part or full, with operating instructions with this symbol can result in serious personal injury or fatal accidents. Warning information must be **strictly** adhered to.



**CAUTION !**

Non-compliance, either in part or full, with operating instructions with this symbol can result in major damage to machinery, property, or material. Information in the "Caution" category is to be **exactly** adhered to.



**NOTE**

Following the instructions marked with this symbol will lead to more effective and straightforward operation. "Note" directions make work easier.

## 0.2 General safety regulations and organizational measures

The instruction manual for the electric chain hoist must always be available within the operating area of the hoist. The information on the electric chain hoist's type and data plate must be checked against Table 5-1 or 5-2, page 22 and the corresponding dimensioned drawing. The dimensioned drawing also shows the dimensions of the electric chain hoist. This ensures that this instruction manual can be clearly assigned to the electric chain hoist. The instruction manual must be strictly adhered to. Furthermore, supplementary to the instruction manual, the statutory regulations governing general accident prevention and environmental protection are to be enforced. Operating and service personnel must have read and understood the instruction manual, in particular the safety instructions, before commencing work. Protective equipment must be made available for operating and service personnel and worn at all times. The operator or their representative is responsible for supervising operating personnel and ensuring they are aware of the hazards and safety implications of working with the electric chain hoist.

The manufacturer reserves the right to make technical changes to the product or changes to these instructions and assumes no liability for the completeness and up-to-dateness of these instructions. The original version of these instructions is in the German language. In case of doubt, the original German version is exclusively valid as a reference document.

### 0.2.1 Warning markings / Legends / Warning plates

- Oil chain.....figure 0-1
- Data plate .....figure 0-2
- Voltage..... figure 0-3

Figure 0-1

Figure 0-2

Figure 0-3



## 0.3 Particular safety instructions/Transport and assembly:

**Transport / assembly:**

- Electric chain hoists, single parts and large components should be carefully fixed to suitable and technically acceptable hoisting apparatus / load handling devices.

**Connection:**

- Connection work is only to be performed by personnel specifically designated and trained for the job.

**Start-up / operation:**

- Before initial start-up as well as daily start-up, carry out a visual check and carry out the stipulated user-checks routine.
- Only operate the electric chain hoist if the protective and safety equipment provided is ready and working.
- Damage to the electric chain hoist and changes in its operational characteristics must be reported immediately to the responsible person.
- After use, or when in a non-operational mode, the electric chain hoist should be secured against unauthorized and unintentional use.
- Refrain from hazardous procedures.

See also operational parameters (chapter 0.6).

**Cleaning / service / repair / maintenance / refitting:**

- Use working platforms provided for assembly work at high level.
- Do not use machine parts for this purpose.
- Check electrical cables for damage or wear.
- Ensure any oils or other agents used are collected and disposed of safely and in an environmentally sound manner.
- Reassemble and check safety devices that have been disassembled for maintenance or repair of the hoist once service and repair work has been completed.
- Adhere to predefined testing and service intervals specified in the instruction manual.
- Follow the directions in the instruction manual regarding exchanging parts.
- Operating personnel should be informed before commencing special or repair work.
- Secure the repair working area.
- Prevent the electric chain hoist from being unexpectedly switched on during maintenance or repair work.
- Attach warning plates.
- Disconnect the power cable and ensure it cannot be switched on again by unauthorized personnel.
- Retighten screw connections that have been loosened for repair or maintenance work.
- Replace non-reusable fixing elements (e.g. self-locking nuts, washers, cotter pins, O-rings and seals).

**Shut down / storage:**

- Clean and preserve (lubricate/grease) the electric chain hoist before long periods of inactivity or storage.

## 0.4 Instructions for hazard protection

Hazardous areas must be clearly marked by warning plates and cordoned off. It must be ensured that warnings regarding hazardous areas are given due attention.

**Hazards can stem from:**

- incorrect application
- not following safety directions properly
- not carrying out test and service work thoroughly

### 0.4.1 Hazards - Mechanical

**Physical injury:****Unconsciousness and injury through:**

- crushing, shearing, cutting, and twisting
- drawing in, ramming, piercing, and rubbing
- slipping, stumbling, and falling

**Causes:**

- crushing, shearing, and twisting
- parts rupturing or bursting

**Safety options:**

- keep floor, equipment, and machinery clean
- eliminate leakages
- observe the required safety distance

**0.4.2 Hazards - Electrical**

Work on electrical apparatus or machinery may only be performed by qualified electricians or persons under the supervision and guidance of qualified electricians, in accordance with electrical regulations.



**Physical injury:**

**Death from electrical shock, injury, and burns through:**

- contact
- faulty insulation
- faulty maintenance or repair work
- short circuit

**Causes:**

- contact with, touching or standing too close to uninsulated power and live parts
- use of uninsulated tools
- exposed electricity supply terminals following insulation failure
- inadequate safety checks following repair work
- incorrect fusing

**Safety options:**

- Isolate machinery and equipment designated for repair or maintenance work before commencing such work.
- First check isolated parts for voltage.
- Regularly check electrical fittings.
- Replace loose or damaged cables immediately.
- Always replace blown fuses with fuses of the correct type/value.
- Avoid contact with or touching live terminals.
- Only use insulated tools.

**0.4.3 Sound pressure level**

Tests on the chain hoist sound level are performed at a range of 1, 2, 4, 8 and 16 meters (3, 7, 13, 26, and 52 feet) from the center of the electric chain hoist motor to the measuring device.

The sound pressure level was measured:

- a) During operation of electric chain hoists on factory site.
- b) During open-air operation of electric chain hoists.

Table 0-1 Sound pressure level

Measuring distance		1 m (3 ft)	2 m (7 ft)	4 m (13 ft)	8 m (26 ft)	16 m (52 ft)
Series	Measurement type	dBA				
SP 250/500, SPM 250	a	65	62	59	56	53
	b	65	59	53	47	41
SP 250/500 1Ph, SPM 250 1Ph	a	76	73	70	67	64
	b	76	70	64	58	52
SP 1000, SP 1000 1Ph	a	80	77	74	71	68
	b	80	74	68	62	56
SP 1600/2500	a	80	77	74	71	68
	b	80	74	68	62	56



When working in a noisy environment, the use of ear protection is recommended.

## 0.5 Periodic checks

Each device/unit operator should adequately note all checks, maintenance and inspections performed in the inspection pass, and have these confirmed by the competent person in charge. Incorrect or missing entries will lead to forfeiture of the manufacturer's warranty.



Devices and cranes are to be checked periodically by a specialist. Primarily, visual and functional checks are to be carried out, whereby the state of components with respect to damage, wear, corrosion, or any other changes is determined. In addition, safety equipment is assessed for completeness and efficiency. It may be necessary to dismantle the equipment to correctly assess wear parts.



Load-bearing parts must be inspected over their entire length, including covered or hidden parts.



All periodical inspections should be arranged by the operator.

### 0.5.1 Warranty

The warranty is void if the installation, operation, testing and maintenance is not carried in accordance with this instruction manual. Repairs and troubleshooting under warranty may only be carried out by qualified persons after consultation and agreement with the manufacturer/supplier. Any modifications to the product or the use of non-original spare parts will void the warranty.

## 0.6 Appropriate use

The electric chain hoists of the SP types are lifting equipment for various loads. They can be installed as stationary or mobile units, while a lateral oscillation must be ensured. The electric chain hoists are manufactured in accordance with the latest technical developments and recognized safety standards, and are tested for safe operation by the manufacturer. Electric chain hoists are approved by various international classification societies such as TÜV and others. Electric chain hoists of the above types may only be used when in an acceptable technical condition, in accordance with their intended use, by trained personnel in a safe and responsible manner.

### General operating conditions:

- Ambient temperature ..... : -15 °C to +50 °C (5 °F to 122 °F)
- Humidity ..... : max. 80% relative humidity
- Protection class ..... : IP 65
- Electromagnetic compatibility ..... : Immunity, industrial area

We recommend equipping chain hoists working outdoors with a canopy to protect them from the weather or to move the chain hoist, trolley and travel drive under a canopy when not in use. Special operating conditions can be agreed in individual cases with the manufacturer. After consultation, appropriate, optimized equipment, and important information for safe, low-wear use can be supplied. The intended use of the electric chain hoist likewise assumes the adherence to the operating, maintenance and servicing prescribed by the manufacturer.

### Improper use comprises:

- exceeding the defined maximum permissible load capacity
- pulling the load diagonally (maximum angle 4°, see figure 0-6)
- heaving, pulling, or dragging the load
- transporting persons
- moving loads over persons
- standing under suspended loads (see Figure 0-7)
- transporting excessive loads
- pulling on the control cable
- failing to observe the load hook constantly
- running the chain over edges
- failing to observe the load constantly
- allowing the load to fall due to a slack chain
- use in an explosive environment

Refer also to chapter 0.3.



Figure 0-6

Figure 0-7

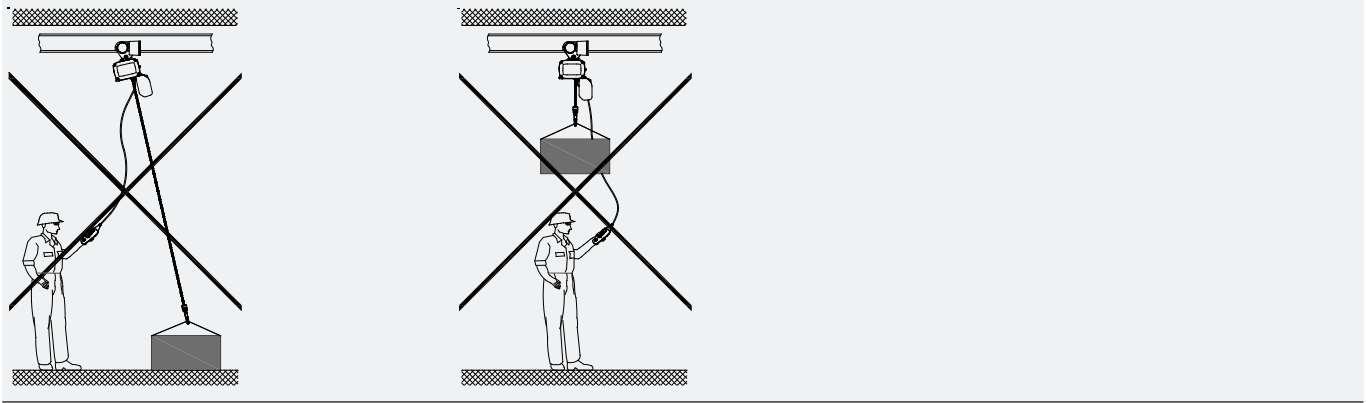

Excessive inching operations, slack chains and driving against the limit stops should be avoided. The loads shall be lifted off the ground with the lowest available lifting speed. If these instructions are not followed, the manufacturer accepts no liability for damage to equipment and third parties caused by such actions.



With pole-changeable motors the slow speed is only suitable for driving and braking. In short time operation max. 20% of the fast gear duty cycle.

**0.6.1 Use of the instruction manual**

This instruction manual includes the following chapters:

- |                       |                                                 |
|-----------------------|-------------------------------------------------|
| 0 General information | 3 Care and maintenance                          |
| 1 Description         | 4 Measures for achieving safe operating periods |
| 2 Start-up            | 5 Appendix                                      |

Supplementary to the instruction manual, the following documentation from the operator must be noted:

- Inspection pass
- Spare parts list(s)
- Circuit diagrams

**Page and figure numbering:**

The pages are consecutively numbered. Blank pages are not numbered, however are calculated together with the consecutive pages. Figures are numbered consecutively by chapter. Example: Figure 3-1 means: in chapter 3, figure 1.

# 1 Description

The SP series includes the following models: SPM, SP, SP special versions.



The travel trolley must have at least the same lifting capacity as the electric chain hoist.



The classification of the electric chain hoist can be found on the data plate.

The manufacturer will only guarantee the safety and lasting operation of the electric chain hoist when used for applications in accordance with valid standard values that fall within its classification.

Before the initial start-up, the user must estimate according to the parameters in table 1-1, which of the four types of load is applicable to the use of the electric chain hoist during its whole life cycle. The table 1-2 shows standard values for the operating conditions of the classifications depending on the type of load and number of cycles.

Table 1-1 Load spectrums

Load type Q2 light $Q < 0.50$ $Q = 0.50$	Load type Q3 medium $0.50 < Q < 0.63$ $Q = 0.63$	Load type Q4 heavy $0.63 < Q < 0.80$ $Q = 0.80$	Load type Q5 very heavy $0.80 < Q < 1.00$ $Q = 1.00$
Full load only by way of an exception, however predominantly low loads	Often fully loaded, however continuously lightly loaded	Frequently fully loaded continuous average loading	Regularly fully loaded

Q = Load spectrum (type of load)

Table 1-2 Operating conditions

(ISO and HMI)	(M3/H2)	(M4/H3)	(M5/H4)	(M6/H4)	(M7/H4 or H5)
Load spectrum	Number of cycles per working day (hoisting classes Dh2 - Dh5, lifting speed 8 m/min) (26 ft/min)				
Q2 - light $Q < 0.50$	120	240	480	960	1,920
Q3 - medium $0.50 < Q < 0.63$	60	120	240	480	960
Q4 - heavy $0.63 < Q < 0.80$	30	60	120	240	480
Q5 - very heavy $0.80 < Q < 1.00$	15	30	60	120	240

**Ascertaining the correct type of application for an electric chain hoist:**

Either the number of cycles or expected type of load can be used as a basis for ascertaining the correct type of application for the electric chain hoist.



Before initial start-up of the electric chain hoist, it is necessary to ascertain which of the load types in table 1-1 applies to the operation of the electric chain hoist. Assignment to a load type or a load spectrum (Q) applies for the whole service life of the equipment and may not be altered for operational safety reasons.

**Example 1: Calculate permissible operating time of the electric chain hoist**

An electric chain hoist of the classification A4 is to be used for medium stress load tasks throughout its whole calculated service life. This corresponds to the type of load "Q4 heavy" (see table 1-1). Corresponding to the values in table 1-2, the electric chain hoist should not be used for more than 60 cycles per day.

**Example 2: Calculate the permissible type of load**

An electric chain hoist of the classification A5 is to be used for approximately 400 cycles per working day, throughout its whole service life. Thus, the electric chain hoist must be operated in accordance with the characteristics of the type of load 'Q2 light' (see table 1-1).

**1.1 General description**

Figure 1-1

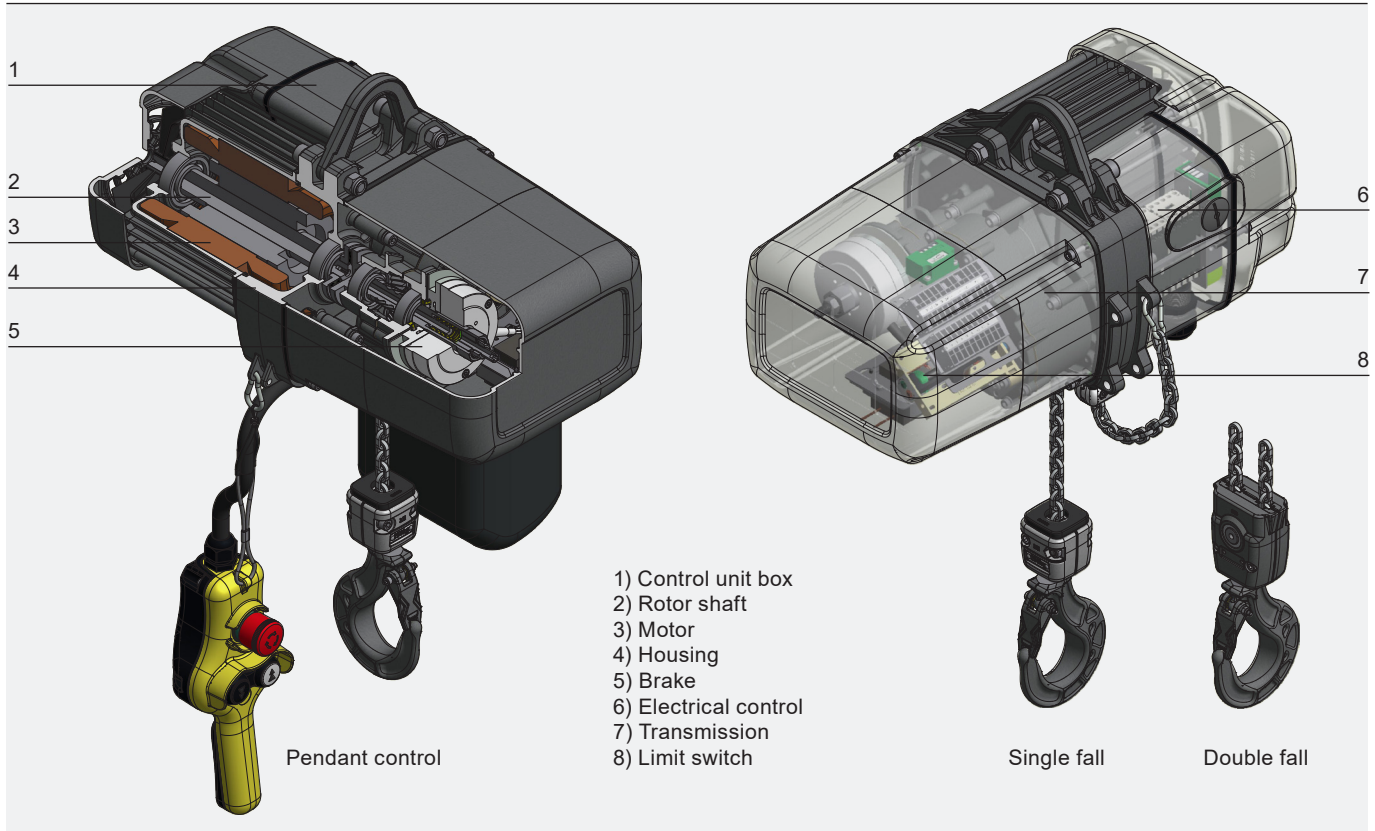

Housing and cover of the electric chain hoist are made of a sturdy die-cast aluminium. Cooling fins and a fan on the attached motor ensure optimum cooling. The chain container can be attached to the compactly constructed housing. A drilled hole is provided for the power supply cable gland and for the cable gland for the control cable. The eyebolt suspension or optional hook suspension are attached on the housing.

Electric chain hoists are driven by asynchronous motors. Two-speed models include a pole-changeable version of the motor.

The braking system consists of one DC-operated magnetic brake. When there is no current, pressure springs generate the braking torque.

The slipping clutch is installed in front of the braking system due to its function. It protects the chain hoist from overload and takes on the function of an emergency stop for the highest and lowest hook positions. A geared limit switch is installed to limit the highest and lowest hook position. Optionally, downstream forced disconnecting emergency stop contacts can be retrofitted.

The electric chain hoists are equipped with a 42 V contactor control as standard. The generally built-in emergency stop contactor disconnects all three main phases from the mains when the red emergency stop button is pressed.

The gears are mounted on roller bearings and run with grease lubrication.

The standard equipment of the electric chain hoist includes a pendant control (up/down with emergency stop). The special versions are described in a separate instruction manual.

## 1.2 Emergency stop

By pressing the emergency stop button, the power supply to the electric chain hoist is interrupted in all phases. The movement of the electric chain hoist is stopped immediately. To unlock the emergency stop button, it must be turned in the indicated direction.



After an emergency stop, the operator may only restart the electric chain hoist after a competent person is satisfied that the cause which led to the emergency stop has been eliminated and that there is no longer any danger from further operation of the system.

## 2 Start-up



Mechanical adjustments may only be performed by authorized specialists.



Operating staff must carefully read the instruction manual of the electric chain hoist before initial start-up and carry out all the checks. The device shall be put back into operation only after operational safety has been established. Unauthorized persons may not operate the device or carry out work with it.



The operator must create an inspection pass during the commissioning of the electric chain hoist. The inspection pass contains all the technical data and the date of commissioning. It provides a record of all servicing and maintenance work.

### 2.1 Transport and assembly

The safety directions for handling with loads should be followed (see chapter 0.3) when transporting and assembling the electric chain hoist. Electric chain hoists must be assembled by qualified staff, always bearing in mind the accident prevention directions in chapter 0.2. Before assembly, the electric chain hoist must be stored in an closed room or covered area. Should the electric chain hoist be destined for operation outdoors, then it is recommended that a protective cover is erected to shield it from the effects of the weather. Wherever possible, the electric chain hoist should be transported in its original packaging. The goods delivered should be checked for completeness and the packaging disposed in an environmentally sound manner. It is recommended that the electric chain hoist is assembled and connected on-site by qualified personnel.

### 2.2 Connections

#### 2.2.1 Electrical connections



Electrical installations may only be performed by authorized specialists.

The mains connection cable, the mains connection fuse and the main switch for connecting the electric chain hoist to the mains power supply must be provided by the customer. A 4-wire cable with a PE protective conductor is needed as a supply line for three-phase versions. A 3-wire cable with a protective conductor is adequate for single-phase version. The length and cross-section must be appropriate for the power consumption of the electric chain hoist.

- Before connecting the electric chain hoist, check whether the operating voltage and frequency specified on the type plate correspond to the available power supply.
- Remove the cover from the control unit box.
- Introduce the connection cable with cable gland M25 × 1.5 through the lower or side hole and connect in accordance with the attached electrical chart to L1, L2, L3 and PE (see figure 2-1).
- Introduce the control cable through cable gland M20 × 1.5 in the hole below the housing and connect to terminals 1, 2, 3, 4, 10 (see figure 2-2).
- Mount strain relief to housing (see Figure 2-3).
- Re-fit the cover from the control unit box.



- To maintain the predetermined protection class IP 65, all cables must fit into the corresponding cable glands and the cover screws must be tightened after the connection with the torque specified in table 3.2.8.
- Open holes must be provided with a sealing plug.
- The pendant control must be attached to the strain relief cord and not to the cable.

Figure 2-1

Figure 2-2

Figure 2-3

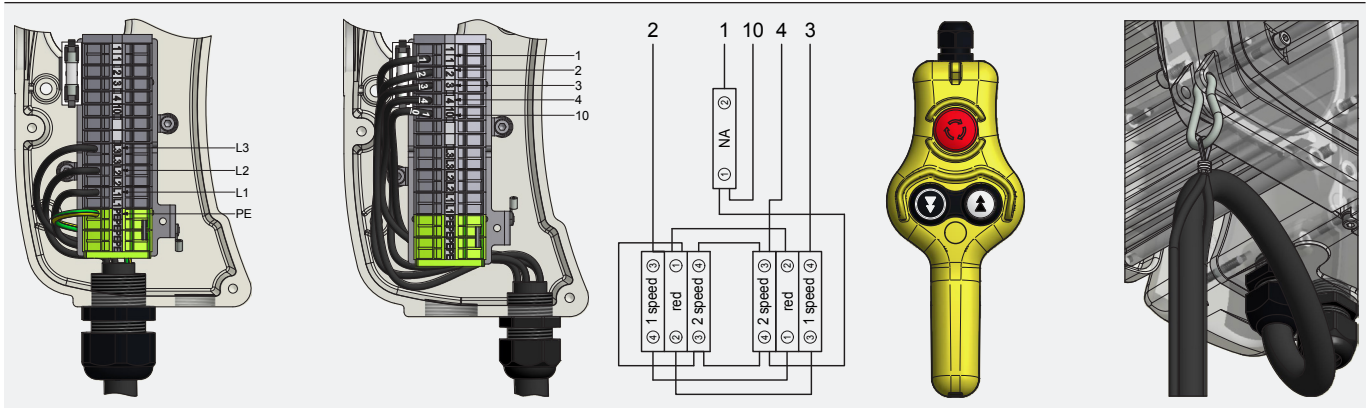

The protective conductor should not conduct any current during operation. With the installation of a motor protection breaker, the current of the electric chain hoist must be observed in accordance with the type plate.



- To check the hoist direction of rotation: The "UP" button must be depressed first.
- Checking direction of rotation: If the directions of movement do not match the button symbols of the pendant control, the supply line wires L1 and L2 must be transposed.
- In the single-phase version, inching operations can cause malfunctions.
- With the cover removed, observe the rotating fan wheel (1, see Figure 2-4).



Open the terminal used in accordance with figure 2-5.

Figure 2-4

Figure 2-5

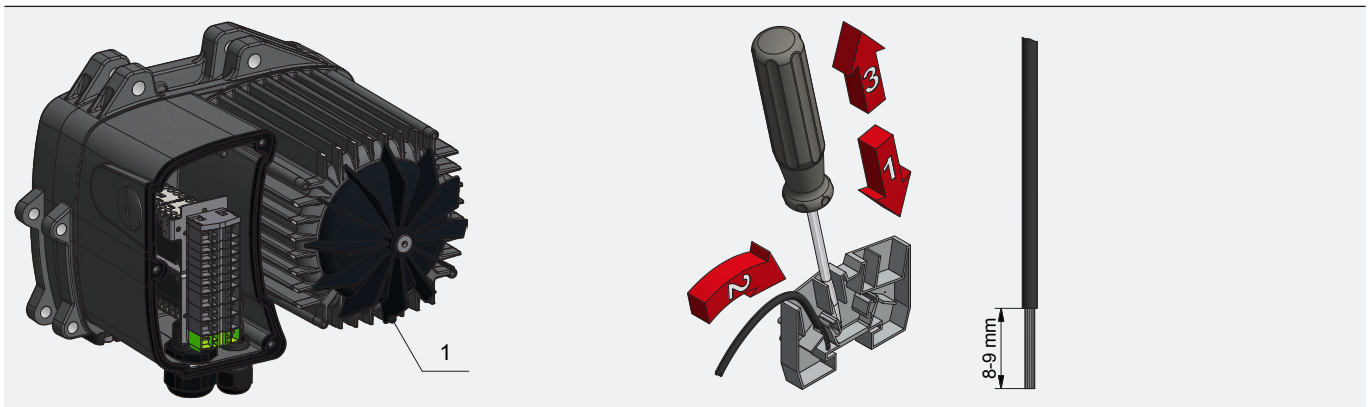

**2.2.2 Load chain**



- Only use original chains.
- Welding seam of the chain links must face inward on the chain wheel (see figure 2-6).
- The geared limit switch must be mechanically deactivated for pulling in the chain, see chapter 2.2.3.

Before start-up and during operation, the load chain must be oiled along its full length. Oil must constantly be present on the internal, contacting and rubbing surfaces of the chain links. Lubrication is carried out by submersion or with an oil can, using a creeping gear oil (GIS chain oil or SAE 15W-40). The end of the chain (1) should be attached to a flexible piece of wire or chain pulling loop (2) and fed through the chain wheel (3) of the electric chain hoist. Through short switching impulses, the chain will be pulled in correctly in accordance with figure 2-6. The lifting height must be adjusted such that the hook fittings lie on the ground in the lowest hook position.

Figure 2-6

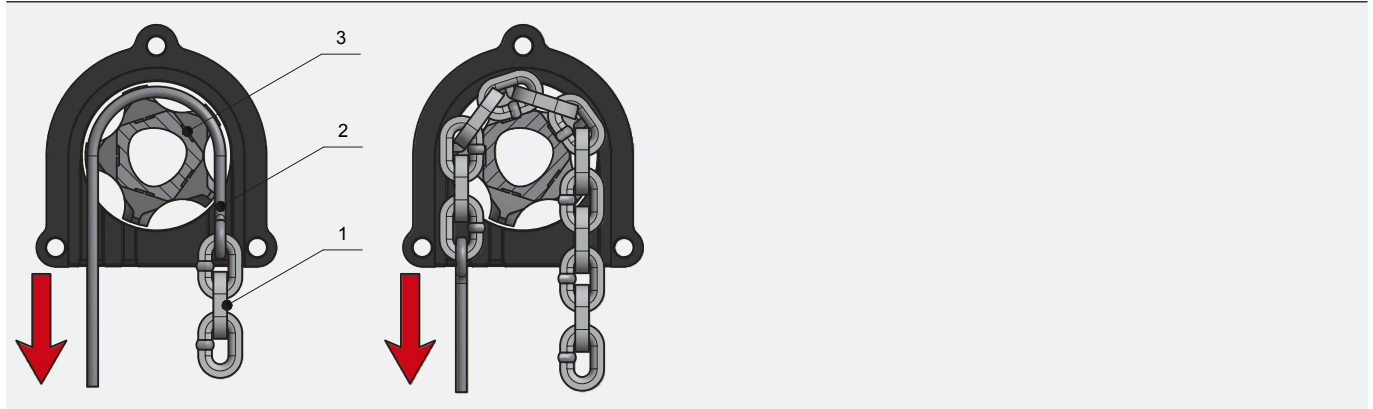

**Chain end:**

The chain end is to be fixed to the housing in accordance with figure 2-7 or figure 2-8 and the limit stop in accordance with figure 2-9. Ensure that the end of the chain is not twisted. The section of chain after the limit stop (1) must be adjusted to the height of the chain container. Here, the length of the chain section must be selected such that the limit stop lies on the floor of the container when the chain is pulled into it (see figure 2-10).

**1 fall operation:**

The load hook (1) is connected to the chain with a single fall hook clamp (2). For the power transmission, the mounting of the bolt (3) is important (see figure 2-11).



- Note correct arrangement of suspension (dimension k1, see figure 2-12 or for SP 2500 see figure 2-13):  
 SPM 250 = symmetrical, SP 250/500 = 41 mm (1.6 in), SP 1000 = 43 mm (1.7 in), SP 1600 = 53 mm (2.1 in), SP 2500 = 87 mm (3.4 in)
- Grease the bearings thoroughly (load hook).

Figure 2-7

Figure 2-8

Figure 2-9

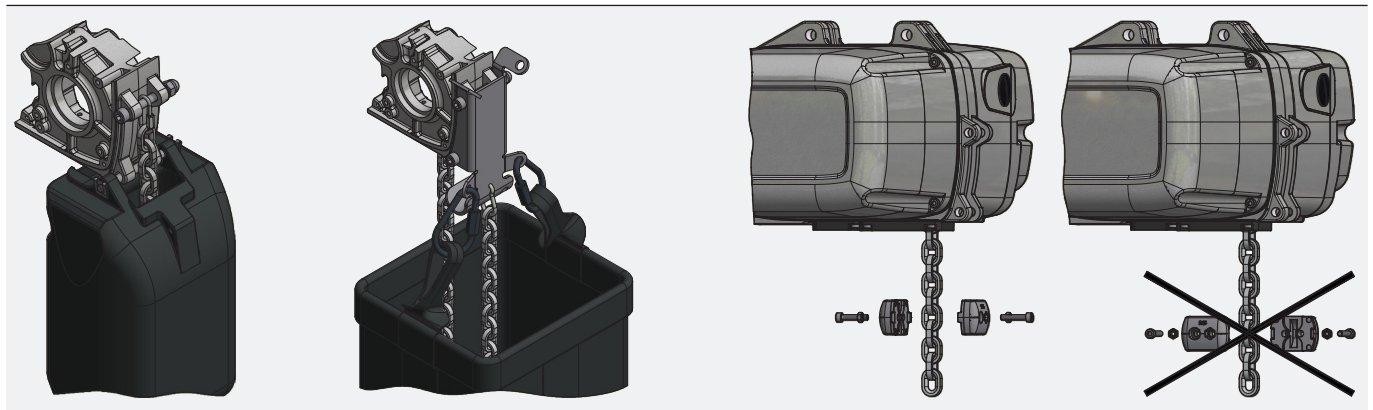

Figure 2-10

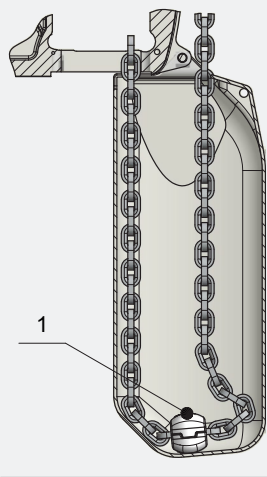

Figure 2-11

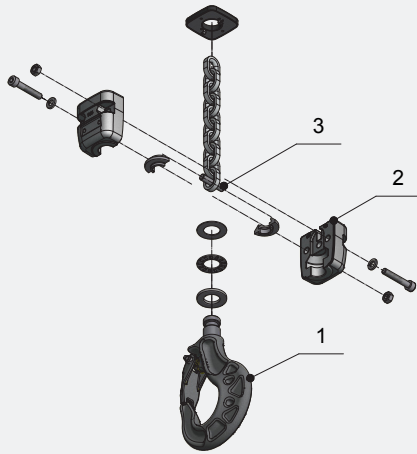
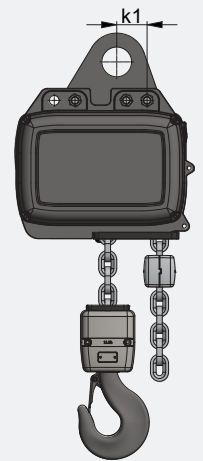

Figure 2-12



Figure 2-13



**Double fall operation (SP 250/500, SP 1000, SP 1600/2500):**

Fit load hook (1) with double fall hook clamp (2) in accordance with figure 2-14. Connect load-side chain end with the chain holder (3) (Tightening torque for model SP 250/500: 10 Nm) and fasten into the guide rail of the housing. Secure the chain holder with screw (4) and spring washer (5).



- Note correct arrangement of suspension (dimension k2, see figure 2-15 or for SP 2500 see figure 2-16):  
 SP 250/500 = 52 mm (2 in), SP 1000 = 62 mm (2 in), SP 1600 = 73 mm (3 in), SP 2500 = 130 mm (5 in).
- No longitudinal twisting of the chain (see figure 2-17).
- Grease the bearings thoroughly (deflection roller / load hook).

Figure 2-14

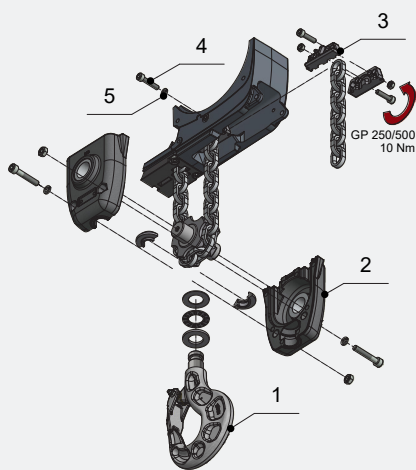

Figure 2-15



Figure 2-16

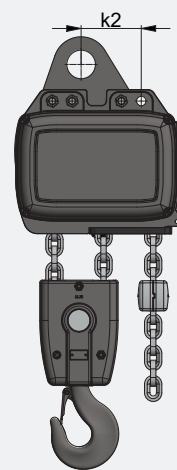
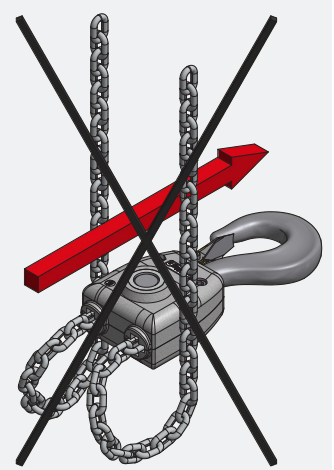

Figure 2-17



### 2.2.3 Limit switch

A geared limit switch is standard in the electric chain hoists. This is also suitable as a regular limit stop with high switching precision. The limit switch function (highest and lowest hook position) must be tested during start-up. Four different transmissions are available depending on the lifting height:

SPM 250			
Transmission	Color	1 fall lifting height [m]	2 falls lifting height [m]
i = 1:1	black	14 (46 ft)	-
i = 1:1.5	red	21 (69 ft)	-
i = 1:3	yellow	42 (138 ft)	-
i = 1:6	blue	90 (295 ft)	-

SP 250/500			
Transmission	Color	1 fall lifting height [m]	2 falls lifting height [m]
i = 1:1	black	19 (62 ft)	9.5 (31 ft)
i = 1:1.5	red	28 (92 ft)	14 (46 ft)
i = 1:3	yellow	57 (187 ft)	28.5 (94 ft)
i = 1:6	blue	114 (374 ft)	57 (187 ft)

SP 1000			
Transmission	Color	1 fall lifting height [m]	2 falls lifting height [m]
i = 1:1	black	30 (98 ft)	15 (49 ft)
i = 1:1.5	red	45 (148 ft)	23 (75 ft)
i = 1:3	yellow	90 (295 ft)	45 (148 ft)
i = 1:6	blue	192 (630 ft)	96 (315 ft)

SP 1600			
Transmission	Color	1 fall lifting height [m]	2 falls lifting height [m]
i = 1:1	black	34 (112 ft)	17 (56 ft)
i = 1:1.5	red	51 (167 ft)	25.5 (84 ft)
i = 1:3	yellow	102 (335 ft)	51 (167 ft)
i = 1:6	blue	204 (669 ft)	102 (335 ft)

SP 2500			
Transmission	Color	1 fall lifting height [m]	2 falls lifting height [m]
i = 1:1	black	42 (138 ft)	21 (69 ft)
i = 1:1.5	red	63 (207 ft)	31.5 (103 ft)
i = 1:3	yellow	126 (413 ft)	63 (207)
i = 1:6	blue	252 (827 ft)	126 (413 ft)

#### Adjustment description (see figure 2-18):

- Provision only with model SPM 250: Loosen screws (1 + 2) and turn clamping strip (3) away (see figure 2-19).
- The geared limit switch must be deactivated mechanically by pressing the rocker switch (1) before drawing the chain in or when changing the chain.
- Draw the chain in.
- Move to the highest hook position and turn the red switch wheel (2, rear) until it reaches the switch cam on the top limit switch (3) (turn clockwise for the lowest hook position and counterclockwise for higher hook positions).
- Activate the rocker switch (1) (the rocker switch must latch into the switch wheel).
- Move to the lowest hook position, press the rocker switch (1) and turn the green switch wheel (4, front) until it reaches the switch cam on the bottom limit switch (5) (turn clockwise for the lowest hook position and counterclockwise for higher hook positions).
- Activate the rocker switch (1) (the rocker switch must latch into the switch wheel).



Check the limit switch function: the limit stop and the bottom hook block may not touch the housing.

### 2.2.4 Chain container

- Extend the chain on the load side until the limit switch is triggered.
- Attach the free end of chain to housing (see chapter 2.2.2).
- Fit the chain container and allow the chain to run in: Plastic chain container (see figure 2-20) or textile chain container: SPM 250: see figure 2-21, SP 250/500: see figure 2-22, SP 1000: see figure 2-23, SP 1600/2500: see figure 2-24.



Figure 2-18

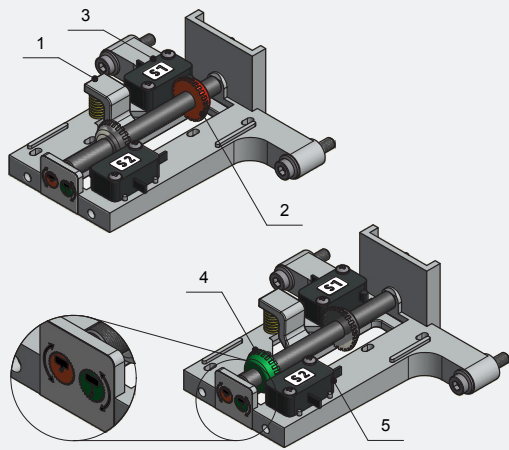

Figure 2-19

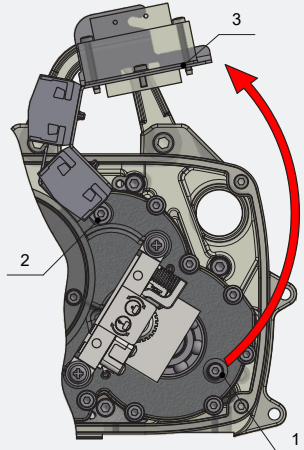

Figure 2-20

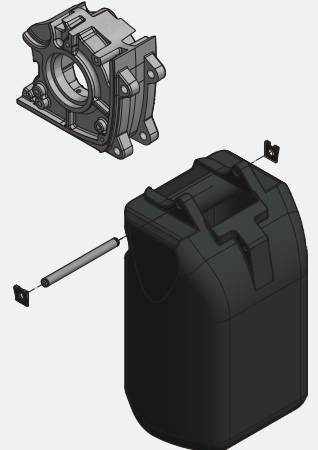

Figure 2-21

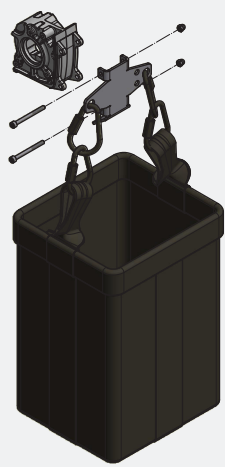

Figure 2-22

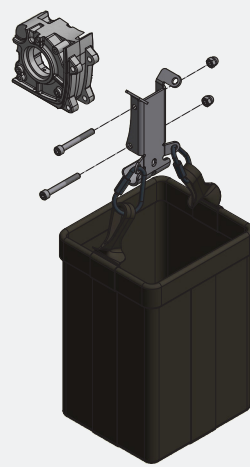

Figure 2-23

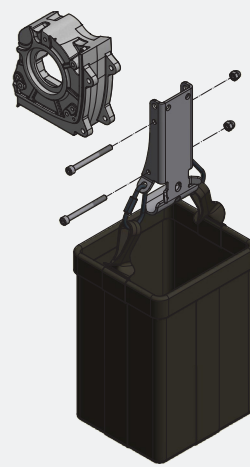
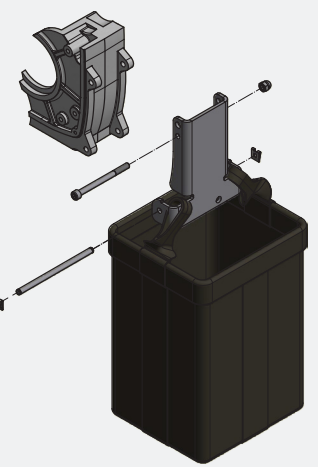

Figure 2-24



### 3 Care and maintenance

#### 3.1 General guidelines for maintenance and repair

Operating failures in electric chain hoists affecting the safe operation of the device should be remedied immediately.



Maintenance and repair work on the electric chain hoist may only be carried out by qualified and trained personnel.



If the operator performs maintenance work on an electric chain hoist on their own, the type of maintenance performed together with the date carried out must be entered in the inspection pass.

Any additions or modifications must be authorized by the manufacturer in advance. Not doing so exempts the manufacturer from liability in the event of damage. Warranty claims will only be valid if the manufacturer's parts are used exclusively. Any part not sent by the manufacturer are invalid for warranty claims.

**General:**

Care and maintenance tasks are preventive measures designed to preserve the full functionality of electric chain hoists. Non-compliance with care and maintenance routines can result in limited use and damage to electric chain hoists.

Care and maintenance should be carried out in accordance with the instruction manual at predefined time intervals (table 3-1 and 3-2). During care and maintenance work, general accident prevention directions, special safety directions (chapter 0.3) as well as hazard protection instructions (chapter 0.4) should be followed.



Care and maintenance work should be performed only on electric chain hoists with no loads. The main switch must be off. The hook fittings must lie on the ground or on the maintenance platform.

Care work encompasses visual checks and cleaning routines. Maintenance work includes additional functional checks. During the functional checks, all fixing elements and cable clamps must be checked for tightness. Cables must be inspected for dirt, discoloration and arc spots.



Used operating materials (oil, grease, etc.) should be safely collected and disposed of in an environmentally friendly manner.

**Care and maintenance intervals are defined as follows:**

d (daily), 3 m (quarterly), 12 m (annually)

The predefined care and maintenance intervals should be reduced when the loading of the electric chain hoist is exceptionally large or when frequently operated in adverse conditions (e.g. dust, heat, humidity, steam, etc.).

## 3.2 Care and maintenance

### 3.2.1 Care overview

Table 3-1 Care overview

Designation	d	3 M	12 M	Task	Remark
1. Load chain	x			Visual check Clean and lubricate as needed	see chapter 2.2.2
2. Lifting device and trolley	x			Check for abnormal noise / sealing	
3. Electric power supply cable	x			Visual check	
4. Limit switch	x			Function check	see chapter 2.2.3
5. Sealing		x		Visual check	
6. Strain relief control cable	x			Visual check	

### 3.2.2 Maintenance overview

Table 3-2 Maintenance overview

Designation	d	3 M	12 M	Task	Remark
1. Load chain		x	x	Oil Measure wear	see chapter 2.2.2 / 3.2.4
2. Brake system	x		x	Function check with load	see chapter 3.2.3
3. Electrical equipment			x	Function check	
4. Fixing screws on suspension parts and load hook with accessories			x	Check for cracks Check screw torque	see chapter 3.2.8
5. Limit switch			x	Check switching elements	see chapter 2.2.3
6. Slipping clutch			x	Function check	see chapter 3.2.7
7. Leaktightness			x	Check screw torques of the covers Check cable glands	see chapter 3.2.8

### 3.2.3 Brake system

The spring-loaded brake is a solenoid-operated, single disc brake with two friction surfaces. The braking force is applied by springs. The braking torque is generated when no current is applied. The brake release is solenoid-operated. The brake operates with DC current. The brake must be able to hold the nominal load in power free mode without any problems.



The brake coil voltage must be the same as the operating voltage.



The brake has no air gap adjustment. If the maximum air gap is reached (a max., table 3-3 and figure 3-1) reached, the lining and the brake disc must be replaced.

Table 3-3 Air gap

Designation		SPM/SP 250	SP 500	SP 1000	SP 1600/2500
Nominal value air gap (a)	[mm]	0.3 (+0.1 / -0.05) .01 (+.003/ -.001)(in)	0.3 (+0.1 / -0.05) .01 (+.003/ -.001)(in)	0.3 (+0.15 / -0.05) .01 (+.006/ -.001)(in)	0.3 (+0.15 / -0.05) .01 (+.006/ -.001)(in)
Air gap (a max.)	[mm]	0.7 (0.03 in)	0.7 (0.03 in)	0.9 (0.04 in)	0.9 (0.04 in)
Holding torque	[Nm]	4 (3 ft/lbs)	7 (5.2 ft/lbs)	12 (8.9 ft/lbs)	22.5 (16.6 ft/lbs)
Screw tightening torque	[Nm]	3 (2.2 ft/lbs)	3 (2.2 ft/lbs)	6 (4.4 ft/lbs)	6 (4.4 ft/lbs)

**3.2.4 Load chain**

The load chain should be periodically checked for abrasion. The check is based on three measurements: see permissible wear values (table 3-4) and measuring points (figure 3-2).



The chain should be replaced when the measurements no longer comply with those defined in the table. The chain wheel and chain guidance should be checked for wear at the same time and, where necessary, be replaced. Only use original chains. The chain links should not be welded.

The new chain is installed in accordance with chapter 2.2.2.



For ease of installation, the old chain and new chain can be connected by a piece of flexible wire.

Table 3-4 Load chain wear values

Designation		SPM/SP 250	SP 500	SP 1000	SP 1600	SP 2500
Chain type d x t	[mm]	3.75 x 10.75 (0.15 x 0.4 in)	5.25 x 15 (0.2 x 0.6 in)	7.45 x 23 (0.3 x 0.9 in)	9.4 x 27.4 (0.4 x 1.1 in)	11.75 x 32.9 (0.5 x 1.3 in)
1. Measurement over 11 chain links, a = 11t	[mm]	120.6 (4.8 in)	168.3 (6.6 in)	258.1 (10.2 in)	307.4 (12.1 in)	369.1 (14.5 in)
2. Measurement over 1 chain link, 1t	[mm]	11.3 (0.4 in)	15.7 (0.6 in)	24.1 (0.9 in)	28.7 (1.1 in)	34.5 (1.4 in)
3. Measurement of the chain link diameter dm = d1 + d2 / 2 (dm min. = 0.9 x d)	[mm]	3.4 (0.1 in)	4.7 (0.2 in)	6.7 (0.3 in)	8.5 (0.3 in)	10.6 ( 0.4 in)

Figure 3-1

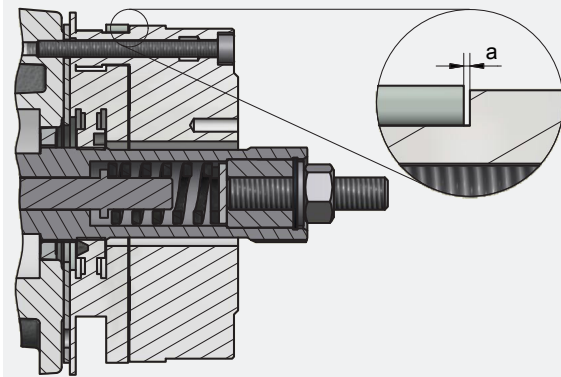
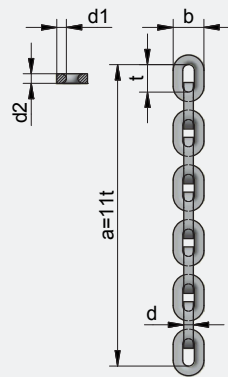

Figure 3-2



**3.2.5 Limit stop**

Check screw fittings at the limit stop and single fall hook clamp and tighten with the correct torque if necessary. See chapter 3.2.8 for guide values.



A damaged stop plate, at the bottom of the housing, must be replaced.

**3.2.6 Transmission**

The transmission has permanent lubrication.



The housing of the transmission may not be opened.

### 3.2.7 Slipping clutch

The slipping clutch is set to 125% at the factory and reliably prevents overloading of the chain hoist. In the case of the two lowest lifting capacities in tables 5-1 to 5-5, the factor is  $\leq 2$ . The resultant forces arising from the adjustment of the slipping clutch must be able to be absorbed by the suspension parts. The coating is wear resistant.



Adjustment and testing of the slipping clutch may only be carried out by authorized personnel and must be recorded in the inspection pass. If the nominal load is no longer lifted, or there is delay in achieving the lifting speed, the slipping clutch must be adjusted.

### 3.2.8 Suspension parts

All statically loaded parts are considered to be suspension parts. The bearing surfaces of the slewing suspension parts must be periodically greased. Torque values for screws of strength class 8.8:

M 4	M 5	M 6	M 8	M 10	M 12
3.3 Nm (2 ft/lbs)	6.5 Nm (5 ft/lbs)	10 Nm (7 ft/lbs)	24 Nm (18 ft/lbs)	48 Nm (35 ft/lbs)	83 Nm (61 ft/lbs)



If hook or eyebolt shows damage, cracks, deformation, or corrosion, it must be replaced. If the prescribed dimensions (min. / max.) no longer comply with table 3-5 and figure 3-3, the parts must also be replaced. The hook safety catch must be fully functional and fully closed, replace if necessary.

Table 3-5 Wear values suspension parts

Suspension part		SPM 250	SP 250	SP 500	SP 1000	SP 1600	SP 2500
Load hook	h [mm]	18.0 (0.7 in)	28.0 (1.1 in)	28.0 (1.1 in)	35.5 (1.4 in)	48.0 (1.9 in)	48.0 (1.9 in)
	h min. [mm]	17.1 (0.7 in)	26.6 (1.0 in)	26.6 (1.0 in)	33.8 (1.3 in)	45.6 (1.8 in)	45.6 (1.8 in)
Hook suspension	h [mm]	18.0 (0.7 in)	28.0 (1.1 in)	28.0 (1.1 in)	35.5 (1.4 in)	48.0 (1.9 in)	48.0 (1.9 in)
	h min. [mm]	17.1 (0.7 in)	26.6 (1.0 in)	26.6 (1.0 in)	33.8 (1.3 in)	45.6 (1.8 in)	45.6 (1.8 in)
Eyebolt suspension	h [mm]	11.0 (0.4 in)	15.0 (0.6 in)	15.0 (0.6 in)	20.0 (0.8 in)	22.5 (0.9 in)	29.0 (1.1 in)
	h min. [mm]	10.5 (0.4 in)	14.3 (0.6 in)	14.3 (0.6 in)	19.0 (0.7 in)	21.4 (0.8 in)	27.5 (1.1 in)
Hook opening	l [mm]	24.0 (0.9 in)	34.5 (1.4 in)	34.5 (1.4 in)	42.6 (1.7 in)	44.6 (1.8 in)	44.6 (1.8 in)
	l max. [mm](in)	26.4 (1.0 in)	37.9 (1.5 in)	37.9 (1.5 in)	46.8 (1.8 in)	49.0 (1.9 in)	49.0 (1.9 in)

Figure 3-3

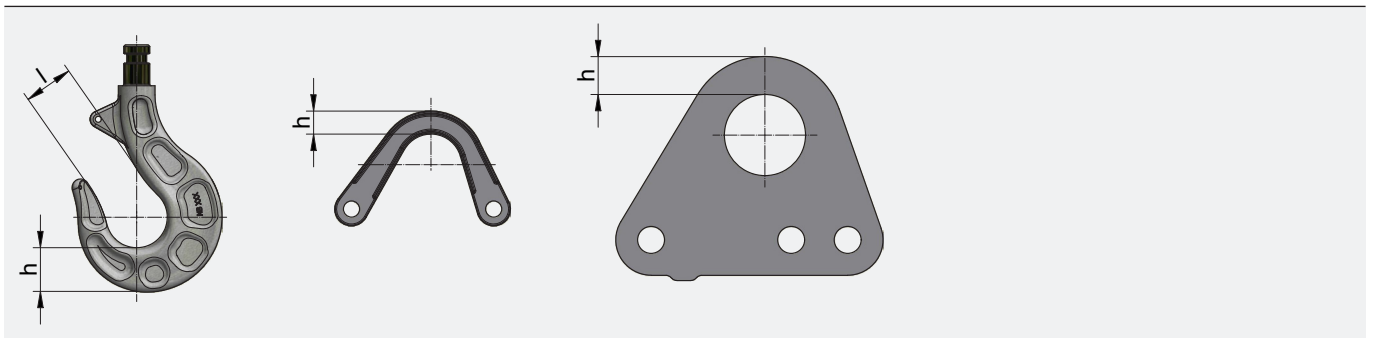

## 4 Measures for achieving safe operating periods

Operators of series lifting device are obliged to determine the actual use. This determination is easiest using the calculator on our website. The actual use is recorded as part of the annual inspection by customer service engineers. A general overhaul must be carried out when the theoretical full load cycles are reached, or after no more than 10 years. All checking and the general overhaul itself must be arranged by the operator of the lifting device.

(ISO and HMI)	(M3/H2)	(M4/H3)	(M5/H4)	(M6/H4)	(M7/H4 or H5)
Load spectrum	Number of load cycles throughout the whole service life				
Q2 = 0.50	250,000	500,000	1,000,000	2,000,000	4,000,000
Q3 = 0.63	125,000	250,000	500,000	1,000,000	2,000,000
Q4 = 0.80	63,000	125,000	250,000	500,000	1,000,000
Q5 = 1.00	31,500	63,000	125,000	250,000	500,000

### 4.1 Determining the actual operating time

The actual operating time depends on the daily operating cycles and the load spectrum. Operating cycles are determined from information provided by the operator or recorded using a meter that counts the number of operating cycles. The load spectrum is determined in accordance with table 1-1, page 10. With these both values, the annual use can be found in table 4-1. If an operating data acquisition system (BDE) is used, the actual use can be read out directly by our experts during the annual inspection.



The values periodically calculated or read-off are to be recorded in the inspection pass.

**Example:**

An electric chain hoist with A4 classification is used with the load type "Q4 heavy" (Q = 0.80, see table 1-1). Use per working day is 60 cycles. According to table 4-1, this results in a theoretical annual use of 6300 full load cycles. A theoretical operating period of 19.8 years can thus be derived from the theoretical total service life of 125,000 full load cycles. A general overhaul must be carried out after 10 years at the latest, during which the further use is determined.

Table 4-1 Annual use (208 working days / year)

Number of cycles per working day	<= 15 (15)	<= 30 (30)	<= 60 (60)	<= 120 (120)	<= 240 (240)	<= 480 (480)	<= 960 (960)	<= 1920 (1920)
Load spectrum	Annual use in full load cycles							
Q2 = 0.50	400	800	1,600	3,150	6,300	12,500	25,000	50,000
Q3 = 0.63	800	1,600	3,150	6,300	12,500	25,000	50,000	100,000
Q4 = 0.80	1,600	3,150	6,300	12,500	25,000	50,000	100,000	200,000
Q5 = 1.00	3,150	6,300	12,500	25,000	50,000	100,000	200,000	400,000

### 4.2 General overhaul

On reaching the theoretical full load cycles (no later than 10 years for recording without BDE), a general overhaul should be performed. This enables the equipment to continue operating safely for a further period of time. Components must be checked or replaced in accordance with table 4-2. The checking and release for the further use must be done by a specialist company authorized by the manufacturer or by the manufacturer themselves.

**The inspector determines:**

- What new theoretical full load cycles are possible.
- The max. period until the next general overhaul.

This data should be recorded in the inspection pass.

Table 4-2 General overhaul

Components of SP models, all types	Check for wear *	Replace
Brake	x	
Motor shaft	x	
Gear teeth		x
Roller bearing		x
Sealings		x
Chain	x **	
Chain wheel, chain guidance	x	
Suspension	x	
Load hook		x
Contactors, limit switch	x	

\* replace if worn

\*\* replace at the latest in general overhaul

### 4.3 Disposal

If the device can no longer be used, it must be disposed of in an environmentally safe manner. Lubricants, such as oils and greases, must be disposed in accordance with the applicable waste law. Metals and plastics are to be recycled.

## 5 Annex

### 5.1 Technical data (Metric)

Table 5-1 Technical data SP (three-phase version)

Series	A3 (M3) 15 C/d (25% ED)	A4 (M4) 30 C/d (30% ED)	A5 (M5) 60 C/d (40% ED)	A6 (M6) 120 C/d (50% ED)	A7 (M7) 240 C/d (60% ED)	A7 (M7) 240 C/d (60% ED)	Lifting speed 50 Hz	Lifting speed 60 Hz	Motor type	Number of falls	Dead weightt 3 m lift	Main fuse (400 V, slow-blow)
	Load capacity [kg]						[m/min]	[m/min]			[kg]	[A]
SPM 250/1NF SPM 250/1SF	- -	320 -	250 125	200 100	160 80	- -	8/2 16/4	9.6/2.4 19.2/4.8	71 B 8/2 71 B 8/2	1 1	17 17	6 6
SP 250/1NF SP 250/1SF SP 250/1NL SP 250/1N	400 - 400 400	320 160 320 320	250 125 250 250	200 100 200 200	160 - 160 160	125 - 125 125	8/2 16/4 4 8	9.6/2.4 19.2/4.8 4.8 9.6	80 B 8/2 80 B 8/2 80 A 4 80 B 2	1 1 1 1	24 24 24 24	6 6 6 6
SP 250/2NF SP 250/2NL SP 250/2N	- - -	630 630 630	500 500 500	400 400 400	320 320 320	250 250 250	4/1 2 4	4.8/1.2 2.4 4.8	80 B 8/2 80 A 4 80 B 2	2 2 2	25 25 25	6 6 6
SP 500/1NF SP 500/1SF SP 500/1NL SP 500/1N	800 - 800 800	630 320 630 630	500 250 500 500	400 200 400 400	320 160 320 320	250 125 250 250	8/2 16/4 4 8	9.6/2.4 19.2/4.8 4.8 9.6	80 B 8/2 80 B 8/2 80 A 4 80 B 2	1 1 1 1	26 26 26 26	6 6 6 6
SP 500/2NF SP 500/2NL SP 500/2N	- - -	1250 1250 1250	1000 1000 1000	800 800 800	630 630 630	500 500 500	4/1 2 4	4.8/1.2 2.4 4.8	80 B 8/2 80 A 4 80 B 2	2 2 2	28 28 28	6 6 6
SP 1000/1NF SP 1000/1SF SP 1000/1NL SP 1000/1N	1600 - 1600 1600	1250 630 1250 1250	1000 500 1000 1000	800 - 800 800	630 - 630 630	500 - 500 500	8/2 16/4 4 8	9.6/2.4 19.2/4.8 4.8 9.6	100 B 8/2 100 B 8/2 90 B 4 100 B 2	1 1 1 1	58 58 57 57	10 10 10 10
SP 1000/2NF SP 1000/2NL SP 1000/2N	- - -	2500 2500 2500	2000 2000 2000	1600 1600 1600	1250 1250 1250	1000 1000 1000	4/1 2 4	4.8/1.2 2.4 4.8	100 B 8/2 90 B 4 100 B 2	2 2 2	62 61 61	10 10 10
SP 1600/1NF SP 1600/1SF SP 1600/1NL	2500 - 2500	2000 1000 2000	1600 800 1600	- - 1250	- - 1000	- - -	8/2 16/4 4	9.6/2.4 19.2/4.8 4.8	100 C 8/2 100 C 8/2 100 AL 4	1 1 1	93 93 88	16 16 16
SP 1600/2NF SP 1600/2NL	- -	4000 4000	3200 3200	- 2500	- 2000	- -	4/1 2	4.8/1.2 2.4	100 C 8/2 100 AL 4	2 2	102 97	16 16
SP 2500/1BF SP 2500/1NF SP 2500/1SF SP 2500/1BL SP 2500/1NL SP 2500/1B	- - - - - -	3200 - - 3200 - 3200	- 2500 1250 - 2500 -	- 2000 1000 - 2000 -	- - - - - -	- - - - - -	6.4/1.6 8/2 16/4 3.2 4 6.4	7.8/1.9 9.6/2.4 19.2/4.8 3.8 4.8 7.8	100 C 8/2 100 C 8/2 100 C 8/2 100 AL 4 100 AL 4 100 C 2	1 1 1 1 1 1	100 100 100 95 95 100	16 16 16 16 16 16
SP 2500/2BF SP 2500/2NF SP 2500/2BL SP 2500/2NL SP 2500/2B	- - - - -	6300 - 6300 - 6300	- 5000 - 5000 -	- 4000 - 4000 -	- - - - -	- - - - -	3.2/0.8 4/1 1.6 2 3.2	3.8/1 4.8/1.2 1.9 2.4 3.8	100 C 8/2 100 C 8/2 100 AL 4 100 AL 4 100 C 2	2 2 2 2 2	117 117 112 112 117	16 16 16 16 16

Table 5-2 Technical data SP (single-phase version)

Series	A3 (M3) 15 Z/d (25% ED)	A4 (M4) 30 Z/d (30% ED)	A5 (M5) 60 Z/d (40% ED)	A5 (M5) 60 Z/d (40% ED)	A5 (M5) 60 Z/d (40% ED)	A5 (M5) 60 Z/d (40% ED)	Lifting speed 50 Hz	Lifting speed 60 Hz	Motor type	Number of falls	Dead weightt 3 m lift	Main fuse (230 V, slow-blow)
	Load capacity [kg]						[m/min]	[m/min]			[kg]	[A]
SPM 250/1NL 1Ph SPM 250/1N 1Ph	- -	- -	250 125	200 100	160 80	125 -	4 8	4.8 9.6	71 A 4 71 A 4	1 1	17 17	10 10
SP 250/1NL 1Ph SP 250/1N 1Ph	- -	- -	250 250	200 200	160 160	125 125	4 8	4.8 9.6	80 A 4 80 A 4	1 1	24 24	10 10
SP 250/2NL 1Ph SP 250/2N 1Ph	- -	- -	500 500	400 400	320 320	250 250	2 4	2.4 4.8	80 A 4 80 A 4	2 2	25 25	10 10
SP 500/1NL 1Ph SP 500/1N 1Ph	- -	- -	500 250	400 200	320 160	250 125	4 8	4.8 9.6	80 A 4 80 A 4	1 1	26 26	10 10
SP 500/2NL 1Ph SP 500/2N 1Ph	- -	- -	1000 500	800 400	630 320	500 250	2 4	2.4 4.8	80 A 4 80 A 4	2 2	28 28	10 10
SP 1000/1NL 1Ph SP 1000/1N 1Ph	- -	- -	1000 500	800 400	630 -	500 -	4 8	4.8 9.6	90 B 4 90 B 4	1 1	56 56	16 16
SP 1000/2NL 1Ph SP 1000/2N 1Ph	- -	- -	2000 1000	1600 800	1250 -	1000 -	2 4	2.4 4.8	90 B 4 90 B 4	2 2	60 60	16 16

## 5.1 Technical data (Imperial)

Table 5-1 Technical data SP (three-phase version)

Series	A3 (M3) 15 C/d (25% ED)	A4 (M4) 30 C/d (30% ED)	A5 (M5) (H4) 60 C/d (40% ED)	A6 (M6) 120 C/d (50% ED)	A7 (M7) 240 C/d (60% ED)	A7 (M7) 240 C/d (60% ED)	Lifting speed 50 Hz	Lifting speed 60 Hz	Motor type	Number of falls	Dead weightt 3 m lift	Main fuse (400 V, slow-blow)
	Load capacity [lbs]						[fpm]	[fpm]			[lbs]	[A]
SPM 250/1NF	-	705	551	441	353	-	32/8	38.4/9.6	71 B 8/2	1	37.5	6
SPM 250/1SF	-	-	276	220	176	-	64/16	76.8/19.2	71 B 8/2	1	37.5	6
SP 250/1NF	882	705	551	441	353	276	32/8	38.4/9.6	80 B 8/2	1	53	6
SP 250/1SF	-	353	276	220	-	-	64/16	76.8/19.2	80 B 8/2	1	53	6
SP 250/1NL	882	705	551	441	353	276	16	19.2	80 A 4	1	53	6
SP 250/1N	882	705	551	441	353	276	32	38.4	80 B 2	1	53	6
SP 250/2NF	-	1389	1102	882	705	551	16/4	19.2/4.8	80 B 8/2	2	55	6
SP 250/2NL	-	1389	1102	882	705	551	8	9.6	80 A 4	2	55	6
SP 250/2N	-	1389	1102	882	705	551	16	19.2	80 B 2	2	55	6
SP 500/1NF	1746	1389	1102	882	705	551	32/8	38.4/4.8	80 B 8/2	1	57	6
SP 500/1SF	-	705	551	441	353	276	64/16	76.8/4.8	80 B 8/2	1	57	6
SP 500/1NL	1746	1389	1102	882	705	551	16	19.2	80 A 4	1	57	6
SP 500/1N	1746	1389	1102	882	705	551	32	38.4	80 B 2	1	57	6
SP 500/2NF	-	2756	2205	1764	1389	1102	16/4	19.2/4.8	80 B 8/2	2	62	6
SP 500/2NL	-	2756	2205	1764	1389	1102	8	9.6	80 A 4	2	62	6
SP 500/2N	-	2756	2205	1764	1389	1102	16	19.2	80 B 2	2	62	6
SP 1000/1NF	3527	2756	2205	1764	1389	1102	32/8	38.4/9.6	100 B 8/2	1	128	10
SP 1000/1SF	-	1389	1102	-	-	-	64/16	76.8/19.2	100 B 8/2	1	128	10
SP 1000/1NL	3527	2756	2205	1764	1389	1102	16	19.2	90 B 4	1	126	10
SP 1000/1N	3527	2756	2205	1764	1389	1102	32	38.4	100 B 2	1	126	10
SP 1000/2NF	-	5512	4409	3527	2756	2205	16/4	19.2/4.8	100 B 8/2	2	137	10
SP 1000/2NL	-	5512	4409	3527	2756	2205	8	9.6	90 B 4	2	135	10
SP 1000/2N	-	5512	4409	3527	2756	2205	16	19.2	100 B 2	2	135	10
SP 1600/1NF	5512	4409 (H4)	3527	-	-	-	32/8	38.4/9.6	100 C 8/2	1	205	16
SP 1600/1SF	-	2205	1764	-	-	-	64/16	76.8/19.2	100 C 8/2	1	205	16
SP 1600/1NL	5512	4409	3527	2756	2205	-	16	19.2	100 AL 4	1	194	16
SP 1600/2NF	-	8818	7055	-	-	-	16/4	19.2/4.8	100 C 8/2	2	225	16
SP 1600/2NL	-	8818	7055	5512	2205	-	8	9.6	100 AL 4	2	214	16
SP 2500/1BF	-	7055	-	-	-	-	25.2/6.3	31.2/7.6	100 C 8/2	1	221	16
SP 2500/1NF	-	-	5512	4409	-	-	32/8	38.4/9.6	100 C 8/2	1	221	16
SP 2500/1SF	-	-	2756	2205	-	-	64/16	76.8/19.2	100 C 8/2	1	221	16
SP 2500/1BL	-	7055	-	-	-	-	12.8	15.2	100 AL 4	1	209	16
SP 2500/1NL	-	-	5512	4409	-	-	16	19.2	100 AL 4	1	209	16
SP 2500/1B	-	7055	-	-	-	-	25.6	31.2	100 C 2	1	209	16
SP 2500/2BF	-	13889	-	-	-	-	12.6/3.1	15.2/4	100 C 8/2	2	258	16
SP 2500/2NF	-	-	11023	8818	-	-	16/4	19.2/4.8	100 C 8/2	2	258	16
SP 2500/2BL	-	13899	-	-	-	-	6.4	7.6	100 AL 4	2	247	16
SP 2500/2NL	-	-	11023	8818	-	-	8	9.6	100 AL 4	2	247	16
SP 2500/2B	-	13899	-	-	-	-	12.8	15.2	100 C 2	2	258	16

Table 5-2 Technical data SP (single-phase version) (Standard)

Series	A3 (M3) 15 Z/d (25% ED)	A4 (M4) 30 Z/d (30% ED)	A5 (M5) (H4) 60 Z/d (40% ED)	A5 (M5) 60 Z/d (40% ED)	A5 (M5) 60 Z/d (40% ED)	A5 (M5) 60 Z/d (40% ED)	Lifting speed 50 Hz	Lifting speed 60 Hz	Motor type	Number of falls	Dead weightt 3 m lift	Main fuse (230 V, slow-blow)
	Load capacity [lbs]						[fpm]	[fpm]			[lbs]	[A]
SPM 250/1NL 1Ph	-	-	551	441	353	276	16	19.2	71 A 4	1	38	10
SPM 250/1N 1Ph	-	-	331	220	176	-	32	38.4	71 A 4	1	38	10
SP 250/1NL 1Ph	-	-	551	441	353	276	16	19.2	80 A 4	1	53	10
SP 250/1N 1Ph	-	-	551	441	353	276	32	38.4	80 A 4	1	53	10
SP 250/2NL 1Ph	-	-	1102	882	705	551	8	9.6	80 A 4	2	55	10
SP 250/2N 1Ph	-	-	1102	882	705	551	16	19.2	80 A 4	2	55	10
SP 500/1NL 1Ph	-	-	1102	882	705	551	16	19.2	80 A 4	1	57	10
SP 500/1N 1Ph	-	-	551	441	353	276	32	38.4	80 A 4	1	57	10
SP 500/2NL 1Ph	-	-	2205	1764	1389	1102	8	9.6	80 A 4	2	62	10
SP 500/2N 1Ph	-	-	1102	882	705	551	16	19.2	80 A 4	2	62	10
SP 1000/1NL 1Ph	-	-	2205	1764	1389	1102	16	19.2	90 B 4	1	124	16
SP 1000/1N 1Ph	-	-	1102	882	-	-	32	38.4	90 B 4	1	124	16
SP 1000/2NL 1Ph	-	-	4409	3527	2756	2205	8	9.6	90 B 4	2	132	16
SP 1000/2N 1Ph	-	-	2205	1764	-	-	16	19.2	90 B 4	2	132	16

## 5.2 Electrical parameters

Table 5-3 Electrical parameters SP (three-phase version)

Series	Motor type	No. of poles	P <sub>N</sub> [kW]	n <sub>N</sub> [1/min]	min. / max. currents and start-up current									
					3 x 400 V, 50 Hz					3 x 230 V, 50 Hz				
					I <sub>N 380</sub> [A]	I <sub>N 415</sub> [A]	I <sub>max</sub> [A]	I <sub>A</sub> /I <sub>N 415</sub>	cos phi <sub>N</sub>	I <sub>N 220</sub> [A]	I <sub>N 240</sub> [A]	I <sub>max</sub> [A]	I <sub>A</sub> /I <sub>N 240</sub>	cos phi <sub>N</sub>
SPM 250	71 B 8/2	8	0.10	675	1.2	1.4	1.6	1.45	0.56	2.2	2.4	2.7	1.45	0.56
		2	0.37	2825	1.6	2.1	2.4	2.75	0.63	2.6	3.2	3.8	2.75	0.63
SP 250/500	80 B 8/2	8	0.18	665	1.4	1.9	2.2	1.45	0.51	2.4	3.1	3.5	1.45	0.51
		2	0.72	2745	2.4	3.4	3.7	2.75	0.77	3.2	4.3	4.7	2.75	0.77
SP 250/500	80 A 4	4	0.55	1420	1.3	1.9	2.2	1.65	0.68	2.6	3.2	4.1	1.65	0.68
SP 250/500	80 B 2	2	0.72	2745	3.2	3.4	3.7	2.75	0.77	5.6	5.9	6.2	2.75	0.77
SP 1000	100 B 8/2	8	0.57	675	3.8	4.3	5.1	1.45	0.58	7.1	7.4	9.0	1.45	0.58
		2	2.3	2790	5.3	6.2	7.8	2.75	0.77	8.2	9.3	10.7	2.75	0.77
SP 1000	90 B 4	4	1.5	1430	3.4	3.8	4.2	1.65	0.76	6.1	6.5	7.4	1.65	0.76
SP 1000	100 B 2	2	2.3	2790	6.2	7.3	8.6	2.75	0.77	10.4	13.2	15.8	2.75	0.77
SP 1600/2500	100 C 8/2	8	0.93	685	4.8	6.0	6.5	2.35	0.53	8.2	9.7	11.0	2.35	0.55
		2	3.7	2820	9.8	9.7	10.5	4.95	0.82	15.8	15.2	16.5	4.95	0.82
SP 1600/2500	100 AL 4	4	2.2	1415	5.3	5.7	6.1	1.65	0.80	7.6	7.8	10.5	1.65	0.80
SP 1600/2500	100 C 2	2	3.7	2820	10.4	10.8	11.7	4.95	0.82	17.8	18.5	19.8	4.95	0.82

Table 5-4 Electrical parameters SP (three-phase version)

Series	Motor type	No. of poles	P <sub>N</sub> [kW]	n <sub>N</sub> [1/min]	min. / max. currents and start-up current									
					3 x 460 V, 60 Hz									
					I <sub>N 460</sub> [A]	I <sub>N 480</sub> [A]	I <sub>max</sub> [A]	I <sub>A</sub> /I <sub>N 480</sub>	cos phi <sub>N</sub>					
SPM 250	71 B 8/2	8	0.11	825	1.2	1.3	1.6	1.45	0.55					
		2	0.44	3425	1.6	1.8	2.4	2.75	0.62					
SP 250/500	80 B 8/2	8	0.22	815	1.2	1.5	1.9	1.45	0.50					
		2	0.86	3345	2.3	2.8	3.2	2.75	0.76					
SP 250/500	80 A 4	4	0.66	1720	1.4	1.5	2.0	1.65	0.67					
SP 250/500	80 B 2	2	0.86	3345	3.2	3.4	3.7	2.75	0.76					
SP 1000	100 B 8/2	8	0.68	825	3.8	4.1	4.7	1.45	0.57					
		2	2.8	3390	5.3	5.8	7.3	2.75	0.76					
SP 1000	90 B 4	4	1.8	1730	3.4	3.8	4.2	1.65	0.75					
SP 1000	100 B 2	2	2.8	3390	6.2	6.5	8.1	2.75	0.76					
SP 1600/2500	100 C 8/2	8	1.15	835	5.1	5.3	5.9	2.35	0.54					
		2	4.5	3420	9.4	9.6	10.2	4.95	0.81					
SP 1600/2500	100 AL 4	4	2.7	1715	5.3	5.7	6.1	1.65	0.79					
SP 1600/2500	100 C 2	2	4.5	3420	10.4	10.8	11.7	4.95	0.81					



Table 5-5 Electrical parameters SP (three-phase version)

Series	Motor type	No. of poles	P <sub>N</sub> [kW]	n <sub>N</sub> [1/min]	min. / max. currents and start-up current									
					3 x 230 V, 60 Hz					3 x 575 V, 60 Hz				
					I <sub>N 220</sub> [A]	I <sub>N 240</sub> [A]	I <sub>max.</sub> [A]	I <sub>A</sub> /I <sub>N 240</sub>	cos phi <sub>N</sub>	I <sub>N 575</sub> [A]	I <sub>max.</sub> [A]	I <sub>A</sub> /I <sub>N 575</sub>	cos phi <sub>N</sub>	
SPM 250	71 B 8/2	8	0.11	825	2.6	3.2	3.5	1.45	0.55	0.9		1.0	1.35	0.65
		2	0.44	3425	3.1	3.8	4.2	2.75	0.62	1.0		1.4	3.5	0.63
SP 250/500	80 B 8/2	8	0.22	815	3.1	3.7	4.0	1.45	0.50	1.1		1.3	1.35	0.54
		2	0.86	3345	3.8	5.3	5.6	2.75	0.76	1.7		2.0	3.5	0.88
SP 250/500	80 A 4	4	0.66	1720	3.7	3.9	4.7	1.65	0.67	1.5		2.0	1.65	0.67
SP 250/500	80 B 2	2	0.86	3345	5.4	6.0	6.7	2.75	0.76	1.9		2.3	3.5	0.88
SP 1000	100 B 8/2	8	0.68	825	8.5	9.3	11.2	1.45	0.57	2.9		3.5	1.65	0.62
		2	2.8	3390	13.0	13.8	16.7	2.75	0.76	4.7		5.3	3.5	0.83
SP 1000	90 B 4	4	1.8	1730	7.7	8.9	9.7	1.65	0.75	3.1		3.5	1.65	0.75
SP 1000	100 B 2	2	2.8	3390	12.4	15.6	16.3	2.75	0.76	5.2		5.8	2.75	0.83
SP 1600/2500	100 C 8/2	8	1.15	835	11.8	12.2	12.5	2.35	0.54	6.0		6.7	2.35	0.59
		2	4.5	3420	21.2	20.0	21.5	4.95	0.81	11.0		14.0	4.95	0.87
SP 1600/2500	100 AL 4	4	2.7	1715	10.8	11.2	11.9	1.65	0.79	4.9		5.4	1.65	0.79
SP 1600/2500	100 C 2	2	4.5	3420	20.8	21.6	23.4	4.95	0.81	8.4		9.4	4.95	0.81

Table 5-6 Electrical parameters SP (single-phase version)

Series	Motor type	No. of poles	P <sub>N</sub> [kW]	n <sub>N</sub> [1/min]	min. / max. currents and start-up current									
					1 x 115 V, 50 Hz					1 x 230 V, 50 Hz				
					I <sub>N 115</sub> [A]	I <sub>max.</sub> [A]	I <sub>A</sub> /I <sub>N 115</sub>	cos phi <sub>N</sub>	I <sub>N 230</sub> [A]	I <sub>max.</sub> [A]	I <sub>A</sub> /I <sub>N 230</sub>	cos phi <sub>N</sub>		
SPM 250	71 A 4	4	0.25	1385	5.7	5.9	1.65	0.55	3.0	3.2	1.95	0.55		
SP 250/500	80 A 4	4	0.55	1420	10.3	11.4	1.95	0.68	5.1	5.9	2.45	0.68		
SP 1000	90 B 4	4	1.5	1420	13.0	17.0	1.95	0.76	6.0	7.5	2.45	0.76		

Table 5-7 Electrical parameters SP (single-phase version)

Series	Motor type	No. of poles	P <sub>N</sub> [kW]	n <sub>N</sub> [1/min]	min. / max. currents and start-up current									
					1 x 115 V, 60 Hz					1 x 230 V, 60 Hz				
					I <sub>N 115</sub> [A]	I <sub>max.</sub> [A]	I <sub>A</sub> /I <sub>N 115</sub>	cos phi <sub>N</sub>	I <sub>N 230</sub> [A]	I <sub>max.</sub> [A]	I <sub>A</sub> /I <sub>N 230</sub>	cos phi <sub>N</sub>		
SPM 250	71 A 4	4	0.30	1685	9.2	9.5	1.65	0.54	3.4	3.7	1.95	0.54		
SP 250/500	80 A 4	4	0.66	1720	13.2	15.1	1.95	0.67	6.6	7.5	2.45	0.67		
SP 1000	90 B 4	4	1.8	1720	14.7	15.0	1.95	0.75	6.9	7.0	2.45	0.75		

# SPANCO® WARRANTY

## PRODUCT WARRANTY COVERAGE

### Two-Year Warranty Coverage:

- Defects in equipment material and workmanship of Spanco Workmate electric chain hoists and equipment
- Defects in equipment material and workmanship of motorized systems and equipment
- Paint coatings and finishes in normal operating environments
- Excludes wear items

Spanco warrants motorized equipment to be free from defects in material and workmanship for a period of two (2) years, commencing on the date of shipment to the first retail purchaser. Spanco warrants its paint and finishes for a period of two (2) years. Warranty claims related to coatings must be accompanied by documentation of the product's application and environmental conditions from time of delivery to time of claim.

## WARRANTY TERMS & CONDITIONS

All warranty claims must be approved by Spanco before any work is performed. Spanco's obligation under this warranty is limited to the replacement or repair of Spanco products at the factory or separate location approved by Spanco. **Other than the above mentioned warranty, Spanco will not honor any other warranties—whether expressed, implied, or statutory—and disclaims any warranties of merchantability or fitness for a particular purpose.** Spanco has the right to reject any warranty claim due to harsh and/or inappropriate environmental conditions.

### Spanco Is Not Liable for:

- Indirect, incidental, or consequential damages including lost profits, operating costs, loss of production, or travel expenses
- Components or accessories not manufactured by Spanco
- Defective equipment or system failure caused by misuse, negligence, and improper installation or maintenance
- Equipment that has been used in excess of its rated capacity or beyond its service factors
- Rework and modification of any equipment that has been altered without Spanco's written authorization
- Freight charges and damage incurred by freight carriers
- Any loss, injury, or damage to persons or property resulting from failure or defective operation of material or equipment
- Any damage to paint coatings and finishes caused by negligence and improper storage, such as temporarily storing an indoor system outdoors

### Reimbursement Disclaimer:

- Written notice of any claimed system defect must be given to Spanco within ninety (90) days of shipment.
- All requests for reimbursement must be accompanied by proper documentation.
- Reimbursement is provided in the form of a credit unless otherwise approved by Spanco management.
- Reimbursement for labor will be provided at a maximum rate of \$75 per hour.
- All reimbursement is subject to approval by Spanco management.

**ABOUT SPANCO®****Our Commitment**

Spanco professionals are dedicated to designing and manufacturing a variety of material handling solutions that meet all applicable CMAA, ANSI, OSHA, and MMA guidelines and standards. Our team of engineers and industry experts combine many years of experience in the material handling industry to manufacture material handling solutions that are backed by the best warranty in the industry.

Spanco production facilities are certified under the ISO 9001:2015 Quality Management System to provide superior quality products. And every welder at Spanco is certified to handle steel (D1.1) in accordance with the rigorous requirements and lab testing established by the American Welders Society (AWS).

Spanco professionals welcome challenging projects that require custom crane engineering. Spanco also offers hundreds of pre-engineered lifting solutions, including Workstation Bridge Cranes, Jib Cranes, Gantry Cranes, Monorails, and Tractor Drives.

# SPANCO®

## Promise to Perform Industries, Inc.

Morgantown, PA | Las Vegas, NV

Toll Free: (800) 869-2080 | Outside US: 1-610-286-7200 | [Spanco.com](http://Spanco.com) | [info@Spanco.com](mailto:info@Spanco.com)

