

WF SCREW TYPE CLAMP OMNIDIRECTIONAL DOUBLE CAM LOCK SCREW TYPE CLAMP

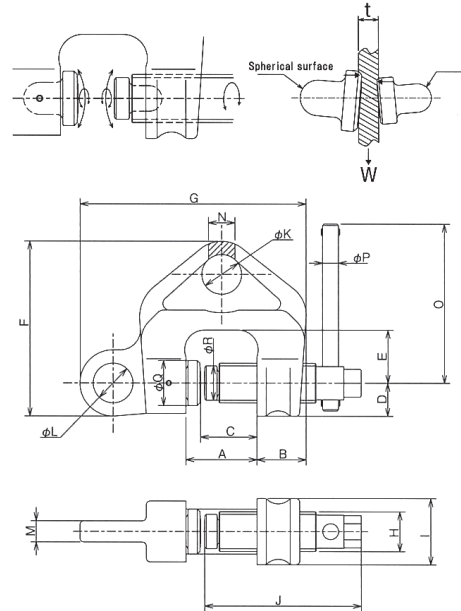

- One of the world's lightest screw clamps: Main body, cam and screw are made of a special alloy steel which is manufactured using our original heat treatment process. They are compact and superior in strength.
- The round double cam lock design allows for a stronger clamping capacity and safe operation. The turning of the round double cams engages the clamp load. Both cams contact the internal spherical surface assuring safe operation, free from slipping.
- Two lifting holes allow for omnidirectional, vertical and horizontal lifts.
- The clamp can be used to hoist inclined loads such as I-beams. **Do not place on a beam taper that exceeds 10°.**
- The fine screw threading creates a vibration resistant clamp.
- Round cam and screw are corrosion resistant with the main body of the clamp having a baked finish.
- Lifting & Transporting: General steel products such as H beams, I beams, steel plate, channel and angle iron. Various structures also include steel braces and pillars.
- Suspension: Clamps can be used for suspending manual chain hoists, electric chain hoists, etc...
- Dragging: The clamps can be used for pulling bottom steel board and other objects along the ground.

SPECS. - WF SCREW TYPE CLAMP

Model	Capacity (t)	Min. Capacity (t)	Jaw Opening (in)	Weight (lbs)
WF-0.5	0.5	0.05	.003-1.10	3.7
WF-1	1.0	0.1	.003-1.57	6.4
WF-2	2.0	0.2	.003-1.77	11.7
WF-3	3.0	0.3	.24-1.93	15.8
WF-5	5.0	0.5	.35-2.08	23.4

DIMS - WF SCREW TYPE CLAMP

Model	A	B	C	D	E	F	G	H	I	J	øK	øL	M	N	O	øP	øQ	øR
WF-0.5	1.61	1.26	1.20	0.83	1.30	4.25	5.43	0.94	1.65	3.86	0.98	0.98	0.47	0.63	4.72	0.39	1.02	0.83
WF-1	2.11	1.50	1.67	0.98	1.57	5.20	6.77	1.18	1.97	4.65	1.18	1.18	0.63	0.79	4.72	0.47	1.34	1.42
WF-2	2.36	1.77	1.87	1.22	1.61	6.18	7.95	1.42	2.44	4.96	1.38	1.38	0.87	1.10	5.91	0.47	1.42	1.14
WF-3	2.58	2.05	2.03	1.38	2.17	6.69	9.06	1.65	2.76	5.47	1.65	1.65	1.10	1.30	6.30	0.47	1.57	1.42
WF-5	2.80	2.24	2.19	1.50	1.81	7.36	9.76	1.89	2.95	5.39	1.81	1.81	1.50	1.57	7.09	0.47	1.61	1.42

ø = Diameter

