

NERP/ERP and NERG/ERG Electric Chain Hoists with Push or Geared Trolleys



NERP/ERP010S
(Shown with optional canvas chain container and rubber bumpers)

Mounting our NER/ER Series hoists to either a PT push or GT geared trolley will create an easy and economical method of transporting the load. This combination is ideal for small workshops and infrequent moves.

Features and Benefits

UL® Listed**

Certified and listed to UL 1340 "Standard for Hoists."

Easy Access Suspension

External pins allow for quick change from hook to lug for trolley mount configurations on most models.

Perpendicular Orientation

PT push trolley mount hoists are configured as perpendicular to the beam. Parallel mount is available as an option. Note 020C and 030C models are parallel mount as standard.

Green Initiative

Built smarter without the use of harmful materials. Environmentally friendly. RoHS compliant.

Notched Hook and Latch System

Provides positive closing and improves resistance against lateral forces.

High Air Flow

Cooler motor and brake attributed to an engineered motor fin, fan blade and fan cover design.

Unique Load Sheave

Increased number of pockets reduce chain vibration and increase chain life. 5 pockets standard; 6 pockets on smaller body hoists.

Extended Chain Life

Decreased chain wear as a result of a revolutionary heat treatment process, improved material and chain size.

Limit Switches

Low-profile upper and lower limit switches are standard.

Contactors

Mechanically interlocked, heavy-duty contactors on single speed models.

Friction Clutch and Load Brake

Friction clutch is standard on NER/ER models and friction clutch with mechanical load brake standard on ER models. Carbon friction material provides consistent performance over a wide temperature range.

High Strength, Corrosion and Wear Resistant Load Chain

Grade 80, super strength, nickel-plated load chain, certified to DIN standards, uses unique technology to greatly increase resistance to fatigue and wear.

Standard Count Hour Meter

Records and displays the number of lowering starts and hoist on time which is valuable for preventive maintenance. Integral to VFD on dual speed models.

Dual Speed VFD

Under-the-cover VFD standard for dual speed hoists. Speed ratio is 6:1 with adjustability up to 12:1.

"The Guardian": Smart Brake Technology

A current driven electromagnetic brake does not release unless the motor is energized. 10 year hoist brake warranty.

Pendant Controls

Ergonomic design for operator comfort. Red button emergency stop is standard on all 2-button dual speed pendants.

Standard Trolley Specifications

Capacity Range

PT Push – 1/8 Ton – 5 Ton
GT Geared – 1/8 – 5 Ton
(See page 38 for 8 – 20 Ton)

Shafts

Standard shafts fit wide range
Longer shafts for wider beams
Spacers for easy adjustments

Drop Stops

Standard

Bumpers

Optional

Standard Hand Chain Drop

Standard geared trolley hand chain hangs approximately 2' less than hoist's fully extended bottom hook (longer drops available)

Wheels

All steel
Sealed ball bearings
Fit flat or tapered beam flange

Standard Hoist Pendant Drop

Standard pendant hangs approximately 4' above the hoist's fully extended bottom hook (longer lengths available)

Standard Hoist Power Supply Length

15' (longer lengths available)

Standard Pendants

Single speed: 2-button (momentary contacts)
Dual speed: 2-button (momentary contacts) with emergency On/Off (maintained contacts)

** Most models shipped with UL listing. Contact Customer Service for listed models. The 3 Ton (N)ERP030L and (N)ERG030L are the previous hoist models.



NERP/ERP010S
(Shown with optional
canvas chain container
and rubber bumpers)

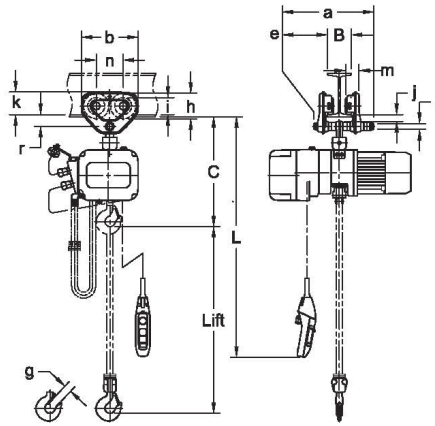

NERP/ERP010S

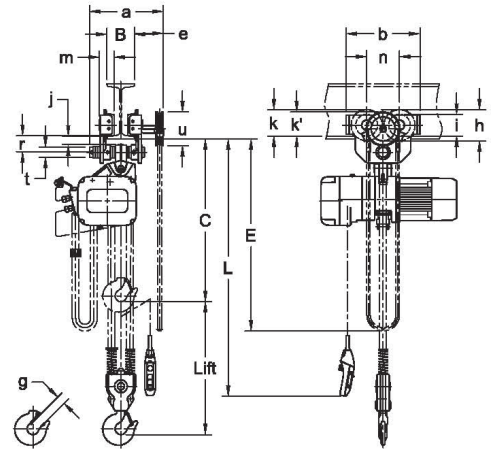

NERG/ERG050L

SINGLE SPEED HOIST WITH PUSH OR GEARED TROLLEY — SPECIFICATIONS

Cap. (Tons)	Product Code	Std. Lift (ft)	Push Button Cord L (ft)	Lifting Speed (ft/min)	Lifting Motor 3 Phase 60 Hz			Flange Width Adjustability B (in)		Min.** Allow. Radius for Curve (in)	Load Chain Diameter (mm) x Chain Fall Lines	Net Weight (lbs)		Weight for Additional One Foot of Lift (lbs)
					Output (Hp)	Rated Current (amps)		Standard	Optional			NER	ER	
						@208-230V	@460V							
1/8	(N)ERP(ERG)001H	10	8.2	55	0.75	3.4	1.7	2.28 to 4.00 (2.28 to 5.00)	4.01 to 8.00 (5.01 to 8.00) OR 8.01 to 12.00	43.3 (51.2)	4.3 x 1	71 (88)	73 (90)	0.28 (.94)
1/4	(N)ERP(ERG)003S			36	0.75	3.4	1.7				6.0 x 1	90 (108)	93 (110)	0.54 (1.1)
1/4	(N)ERP(ERG)003H			53	1.2	4.8	2.5							
1/2	(N)ERP(ERG)005L			15	0.75	3.4	1.7				6.0 x 1	90 (108)	93 (110)	0.54 (1.1)
1/2	(N)ERP(ERG)005S			29	1.2	4.8	2.5	7.7 x 1	121 (130)	128 (137)				
1	(N)ERP(ERG)010L			14	1.2	4.8	2.5				7.7 x 1	137 (146)	137 (146)	0.89 (1.6)
1	(N)ERP(ERG)010S			28	2.4	8.6	4.2	10.2 x 1	187 (196)	201 (209)				
1 1/2	(N)ERP(ERG)015S			18	2.4	8.6	4.2				7.7 x 2	161 (172)	165 (176)	1.8 (2.4)
2	(N)ERP(ERG)020C			7	1.2	4.8	2.5	10.2 x 1	190 (198)	203 (212)				
2	(N)ERP(ERG)020L			14	2.4	8.6	4.2				10.2 x 1	231 (240)	229 (238)	1.6 (2.2)
2	(N)ERP(ERG)020S	28	4.7	16.4	7.9	11.2 x 1	280 (289)	278 (287)	1.9 (2.5)					
2 1/2	(N)ERP(ERG)025S	22	4.7	16.4	7.9					12.5 x 1	311 (322)	311 (322)	2.3 (2.9)	
3	(N)ERP(ERG)030L*	16	4.7	18.3	9.2	10.2 x 2	284 (293)	282 (291)	3.2 (3.8)					
3	(N)ERP(ERG)030C	17	4.7	16.4	7.9					11.2 x 2	399 (415)	395 (410)	3.8 (4.4)	
5	(N)ERP(ERG)050L	11	4.7	16.4	7.9	3.94 to 7.02	7.03 to 12.00	90.6						

Figures in parentheses are data for geared trolley.

*The (N)ERP(ERG)030L listed are the previous hoist models. Refer to Harrington catalog C-EPH for features and benefits.

**Minimum Flange Width for curved beam: 1 Ton Push and 1/8 to 1 Ton Geared = 2.87 in.
3 Ton Push or Geared = 3.50 in

NERP/ERP and NERG/ERG Electric Chain Hoists with Push or Geared Trolleys



NERP/ERP010S
(Shown with optional canvas chain container and rubber bumpers)

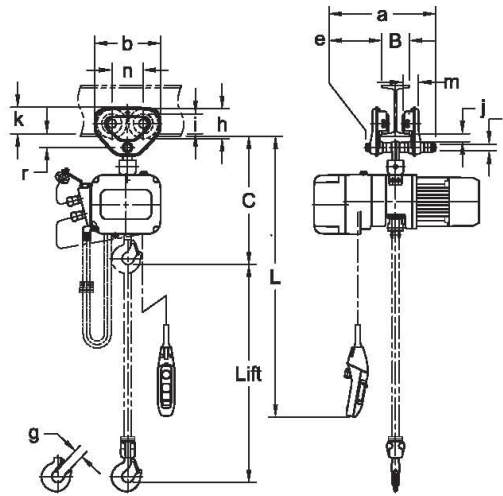

NERP/ERP010S

SINGLE SPEED HOIST WITH PUSH TROLLEY — DIMENSIONS

Cap. (Tons)	Product Code	Headroom C (in)	a (in)	b (in)	e (in)	g (in)	h (in)	i (in)	j (in)	k (in)	m (in)	n (in)	r (in)	t (in)
1/8	(N)ERP001H	15.6	8.0	7.2	1.8	1.1	3.2	2.36	0.8	3.0	1.9	3.3	1.5	0.87
1/4	(N)ERP003S	15.6	8.0	7.2	1.8	1.1	3.2	2.36	0.8	3.0	1.9	3.3	1.5	0.87
1/4	(N)ERP003H	16.3	8.0	7.2	1.8	1.1	3.2	2.36	0.8	3.0	1.9	3.3	1.5	0.87
1/2	(N)ERP005L	16.3	8.0	7.2	1.8	1.1	3.2	2.36	0.8	3.0	1.9	3.3	1.5	0.87
1/2	(N)ERP005S	16.3	8.0	7.2	1.8	1.1	3.2	2.36	0.8	3.0	1.9	3.3	1.5	0.87
1	(N)ERP010L	18.5	9.8	9.3	2.2	1.2	4.2	2.80	1.1	3.7	2.2	4.4	2.0	0.98
1	(N)ERP010S	18.5	9.8	9.3	2.2	1.2	4.2	2.80	1.1	3.7	2.2	4.4	2.0	0.98
1 1/2	(N)ERP015S	22.4	11.8	11.0	2.7	1.4	5.0	3.35	1.4	4.4	2.8	5.2	2.4	1.26
2	(N)ERP020C	27.4	11.8	11.0	2.7	1.5	5.0	3.35	1.4	4.4	2.8	5.2	2.4	1.26
2	(N)ERP020L	25.0	11.8	11.0	2.7	1.6	5.0	3.35	1.4	4.4	2.8	5.2	2.4	1.26
2	(N)ERP020S	25.6	11.8	11.0	2.7	1.6	5.0	3.35	1.4	4.4	2.8	5.2	2.4	1.26
2 1/2	(N)ERP025S	26.8	12.6	12.8	3.1	1.6	5.8	3.94	1.4	5.3	3.1	6.0	2.7	1.42
3	(N)ERP030L*	27.8	12.6	12.8	3.1	1.7	5.8	3.94	1.4	5.3	3.1	6.0	2.7	1.42
3	(N)ERP030C	32.7	12.6	12.8	3.1	1.8	5.8	3.94	1.4	5.3	3.1	6.0	2.7	1.42
5	(N)ERP050L	33.1	11.7	15.7	2.1	1.9	6.7	4.65	1.8	5.6	3.2	7.0	3.4	2.13

*The (N)ERP030L listed is the previous hoist model. Refer to Harrington catalog C-EPH for features and benefits.

HARRINGTON ELECTRIC CHAIN HOISTS



NERG/ERG050L

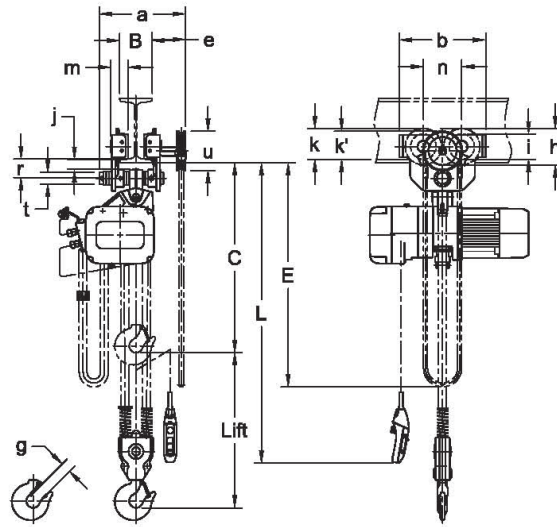

NERG/ERG050L

SINGLE SPEED HOIST WITH GEARED TROLLEY — DIMENSIONS

Cap. (Tons)	Product Code	Headroom C (in)	E (ft)	a (in)	b (in)	e (in)	g (in)	h (in)	i (in)	j (in)	k (in)	k' (in)	m (in)	n (in)	r (in)	t (in)	u (in)
1/8	(N)ERG001H	16.3	10.5	13.6	9.3	6.0	1.1	4.2	2.80	1.1	3.7	4.2	2.2	4.4	1.9	0.98	7.2
1/4	(N)ERG003S	16.3	10.5	13.6	9.3	6.0	1.1	4.2	2.80	1.1	3.7	4.2	2.2	4.4	1.9	0.98	7.2
1/4	(N)ERG003H	17.1	10.5	13.6	9.3	6.0	1.1	4.2	2.80	1.1	3.7	4.2	2.2	4.4	1.9	0.98	7.2
1/2	(N)ERG005L	17.1	10.5	13.6	9.3	6.0	1.1	4.2	2.80	1.1	3.7	4.2	2.2	4.4	1.9	0.98	7.2
1/2	(N)ERG005S	17.1	10.5	13.6	9.3	6.0	1.1	4.2	2.80	1.1	3.7	4.2	2.2	4.4	1.9	0.98	7.2
1	(N)ERG010L	18.5	10.5	13.6	9.3	6.0	1.2	4.2	2.80	1.1	3.7	4.2	2.2	4.4	1.9	0.98	7.2
1	(N)ERG010S	18.5	10.5	13.6	9.3	6.0	1.2	4.2	2.80	1.1	3.7	4.2	2.2	4.4	1.9	0.98	7.2
1 1/2	(N)ERG015S	22.4	10.5	15.2	11.0	6.1	1.4	5.0	3.35	1.4	4.4	4.3	2.8	5.2	2.4	1.26	7.2
2	(N)ERG020C	27.0	10.5	15.2	11.0	6.1	1.5	5.0	3.35	1.4	4.4	4.3	2.8	5.2	2.4	1.26	7.2
2	(N)ERG020L	25.0	10.5	15.2	11.0	6.1	1.6	5.0	3.35	1.4	4.4	4.3	2.8	5.2	2.4	1.26	7.2
2	(N)ERG020S	25.6	10.5	15.2	11.0	6.1	1.6	5.0	3.35	1.4	4.4	4.3	2.8	5.2	2.4	1.26	7.2
2 1/2	(N)ERG025S	26.8	11.0	15.7	12.8	6.2	1.6	5.8	3.94	1.4	5.3	4.5	3.1	6.0	2.7	1.42	7.2
3	(N)ERG030L*	27.8	11.0	15.7	12.8	6.2	1.7	5.8	3.94	1.4	5.3	4.5	3.1	6.0	2.7	1.42	7.2
3	(N)ERG030C	32.7	11.0	15.7	12.8	6.2	1.8	5.8	3.94	1.4	5.3	4.5	3.1	6.0	2.7	1.42	7.2
5	(N)ERG050L	33.1	11.5	15.8	15.7	6.2	1.9	6.7	4.65	1.8	5.6	5.1	3.2	7.0	3.4	2.13	7.2

*The (N)ERG030L listed is the previous hoist model. Refer to Harrington catalog C-EPH for features and benefits.

NERP/ERP and NERG/ERG Electric Chain Hoists with Push or Geared Trolleys

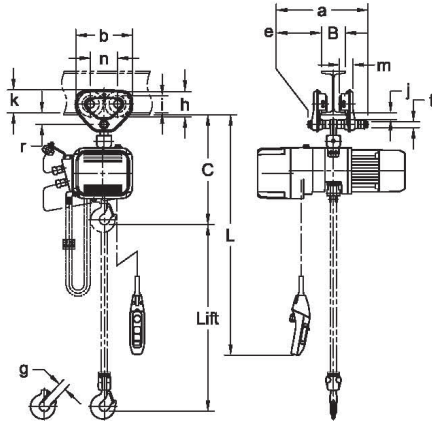

NERP/ERP010SD

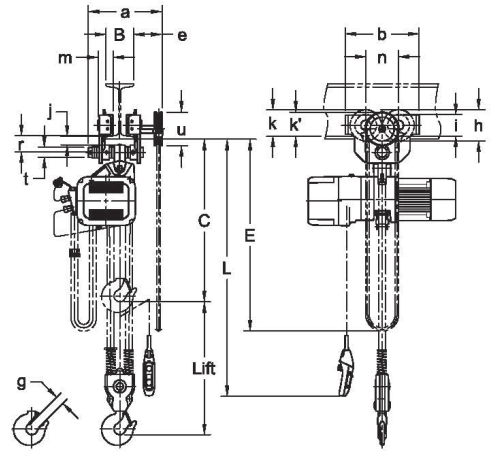

NERG/ERG050LD

NERP/ERP010SD
(Shown with optional canvas chain container and rubber bumpers)

DUAL SPEED HOIST WITH PUSH OR GEARED TROLLEY — SPECIFICATIONS

Cap. (Tons)	Product Code	Std. Lift (ft)	Push Button Cord L (ft)	Lifting Speed (ft/min)	Lifting Motor 3 Phase 60 Hz			Flange Width Adjustability B (in)		Min** Allow. Radius for Curve (in)	Load Chain Diameter (mm) x Chain Fall Lines	Net Weight (lbs)		Weight for Additional One Foot of Lift (lbs)	
					Output (Hp)	Rated Current (amps)		Standard	Optional			NER	ER		
					@208 -	@460V									
1/8	(N)ERP(ERG)001HD	10	8.2	55/9	0.75	3.6	2.28 to 4.00 (2.28 to 5.00)	4.01 to 8.00 (5.01 to 8.00) OR 8.01 to 12.00	43.3 (51.2)	4.3 x 1	71 (88)	75 (92)	0.28 (.94)		
1/4	(N)ERP(ERG)003SD			36/6	0.75	3.6					1.8	71 (88)	75 (92)	0.28 (.94)	
1/4	(N)ERP(ERG)003HD			53/9	1.2	5.1					2.7	6.0 x 1	88 (106)	93 (110)	0.54 (1.1)
1/2	(N)ERP(ERG)005LD			15/2.5	0.75	3.6					1.8	6.0 x 1	80 (97)	90 (106)	0.54 (1.1)
1/2	(N)ERP(ERG)005SD			29/5	1.2	5.1	2.7	6.0 x 1	88 (106)	93 (110)	0.54 (1.1)				
1	(N)ERP(ERG)010LD			14/2.5	1.2	5.1	2.7	2.28 to 5.00	5.01 to 8.00 OR 8.01 to 12.00	51.2	7.7 x 1	117 (126)	126 (135)	0.89 (1.6)	
1	(N)ERP(ERG)010SD			28/4.5	2.4	9.1	4.5				7.7 x 1	132 (141)	135 (143)	0.89 (1.6)	
1 1/2	(N)ERP(ERG)015SD			18/3	2.4	9.1	4.5	3.23 to 6.02	6.03 to 12.00	59.1	10.2 x 1	187 (196)	203 (212)	1.6 (2.2)	
2	(N)ERP(ERG)020CD			7/1	1.2	5.1	2.7				7.7 x 2	154 (165)	163 (174)	1.8 (2.4)	
2	(N)ERP(ERG)020LD			14/2.5	2.4	9.1	4.5				10.2 x 1	190 (198)	203 (212)	1.6 (2.2)	
2	(N)ERP(ERG)020SD			28/4.5	4.7	17.3	8.3				10.2 x 1	227 (236)	234 (243)	1.6 (2.2)	
2 1/2	(N)ERP(ERG)025SD			22/3.5	4.7	17.3	8.3	3.94 to 7.02	7.03 to 12.00	66.9	11.2 x 1	271 (280)	284 (293)	1.9 (2.5)	
3	(N)ERP(ERG)030LD*			17/6	4.7/1.6	19.6/9.4	9.8/4.7				12.5 x 1	355 (366)	355 (366)	2.3 (2.9)	
3	(N)ERP(ERG)030CD			17/3	4.7	17.3	8.3				10.2 x 2	280 (289)	287 (295)	3.2 (3.8)	
5	(N)ERP(ERG)050LD	11/2	4.7	17.3	8.3	3.94 to 7.02	7.03 to 12.00	90.6	11.2 x 2	390 (406)	404 (419)	3.8 (4.4)			

Figures in parentheses are data for geared trolley.

*The (N)ERP(ERG)030LD listed are the previous hoist models. Refer to Harrington catalog C-EPH for features and benefits.

**Minimum Flange Width for curved beam: 1 Ton Push and 1/8 to 1 Ton Geared = 2.87 in.

3 Ton Push or Geared = 3.50 in

Speed ratio is 6:1 with adjustability up to 12:1.

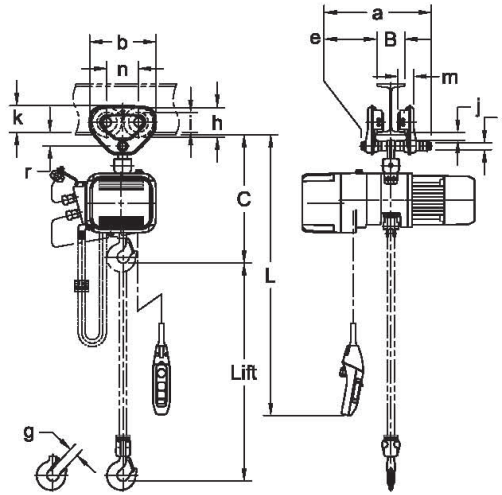

NERP/ERP010SD

NERP/ERP010SD
(Shown with optional
canvas chain container and
rubber bumpers)

DUAL SPEED HOIST WITH PUSH TROLLEY — DIMENSIONS

Cap. (Tons)	Product Code	Headroom C (in)	a (in)	b (in)	e (in)	g (in)	h (in)	i (in)	j (in)	k (in)	m (in)	n (in)	r (in)	t (in)
1/8	(N)ERP001HD	15.6	8.0	7.2	1.8	1.1	3.2	2.36	0.8	3.0	1.9	3.3	1.5	0.87
1/4	(N)ERP003SD	15.6	8.0	7.2	1.8	1.1	3.2	2.36	0.8	3.0	1.9	3.3	1.5	0.87
1/4	(N)ERP003HD	16.3	8.0	7.2	1.8	1.1	3.2	2.36	0.8	3.0	1.9	3.3	1.5	0.87
1/2	(N)ERP005LD	16.3	8.0	7.2	1.8	1.1	3.2	2.36	0.8	3.0	1.9	3.3	1.5	0.87
1/2	(N)ERP005SD	16.3	8.0	7.2	1.8	1.1	3.2	2.36	0.8	3.0	1.9	3.3	1.5	0.87
1	(N)ERP010LD	18.5	9.8	9.3	2.2	1.2	4.2	2.80	1.1	3.7	2.2	4.4	2.0	0.98
1	(N)ERP010SD	18.5	9.8	9.3	2.2	1.2	4.2	2.80	1.1	3.7	2.2	4.4	2.0	0.98
1 1/2	(N)ERP015SD	22.4	11.8	11.0	2.7	1.4	5.0	3.35	1.4	4.4	2.8	5.2	2.4	1.26
2	(N)ERP020CD	27.4	11.8	11.0	2.7	1.5	5.0	3.35	1.4	4.4	2.8	5.2	2.4	1.26
2	(N)ERP020LD	25.0	11.8	11.0	2.7	1.6	5.0	3.35	1.4	4.4	2.8	5.2	2.4	1.26
2	(N)ERP020SD	25.6	11.8	11.0	2.7	1.6	5.0	3.35	1.4	4.4	2.8	5.2	2.4	1.26
2 1/2	(N)ERP025SD	26.8	12.6	12.8	3.1	1.6	5.8	3.94	1.4	5.3	3.1	6.0	2.7	1.42
3	(N)ERP030LD*	30.3	12.6	12.8	3.1	1.7	5.8	3.94	1.4	5.3	3.1	6.0	2.7	1.42
3	(N)ERP030CD	32.7	12.6	12.8	3.1	1.8	5.8	3.94	1.4	5.3	3.1	6.0	2.7	1.42
5	(N)ERP050LD	33.1	11.7	15.7	2.1	1.9	6.7	4.65	1.8	5.6	3.2	7.0	3.4	2.13

*The (N)ERP030LD listed is the previous hoist model. Refer to Harrington catalog C-EPH for features and benefits.
Speed ratio is 6:1 with adjustability up to 12:1.

NERP/ERP and NERG/ERG Electric Chain Hoists with Push or Geared Trolleys



NERG/ERG050LD

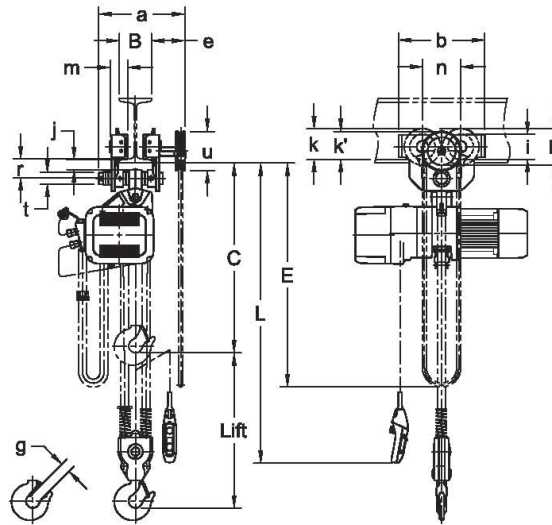

NERG/ERG050LD

DUAL SPEED HOIST WITH GEARED TROLLEY — DIMENSIONS

Cap. (Tons)	Product Code	Headroom C (in)	E (ft)	a (in)	b (in)	e (in)	g (in)	h (in)	i (in)	j (in)	k (in)	k' (in)	m (in)	n (in)	r (in)	t (in)	u (in)
1/8	(N)ERG001HD	16.3	10.5	13.6	9.3	6.0	1.1	4.2	2.80	1.1	3.7	4.2	2.2	4.4	1.9	0.98	7.2
1/4	(N)ERG003SD	16.3	10.5	13.6	9.3	6.0	1.1	4.2	2.80	1.1	3.7	4.2	2.2	4.4	1.9	0.98	7.2
1/4	(N)ERG003HD	17.1	10.5	13.6	9.3	6.0	1.1	4.2	2.80	1.1	3.7	4.2	2.2	4.4	1.9	0.98	7.2
1/2	(N)ERG005LD	17.1	10.5	13.6	9.3	6.0	1.1	4.2	2.80	1.1	3.7	4.2	2.2	4.4	1.9	0.98	7.2
1/2	(N)ERG005SD	17.1	10.5	13.6	9.3	6.0	1.1	4.2	2.80	1.1	3.7	4.2	2.2	4.4	1.9	0.98	7.2
1	(N)ERG010LD	18.5	10.5	13.6	9.3	6.0	1.2	4.2	2.80	1.1	3.7	4.2	2.2	4.4	1.9	0.98	7.2
1	(N)ERG010SD	18.5	10.5	13.6	9.3	6.0	1.2	4.2	2.80	1.1	3.7	4.2	2.2	4.4	1.9	0.98	7.2
1 1/2	(N)ERG015SD	22.4	10.5	15.2	11.0	6.1	1.4	5.0	3.35	1.4	4.4	4.3	2.8	5.2	2.4	1.26	7.2
2	(N)ERG020CD	27.0	10.5	15.2	11.0	6.1	1.5	5.0	3.35	1.4	4.4	4.3	2.8	5.2	2.4	1.26	7.2
2	(N)ERG020LD	25.0	10.5	15.2	11.0	6.1	1.6	5.0	3.35	1.4	4.4	4.3	2.8	5.2	2.4	1.26	7.2
2	(N)ERG020SD	25.6	10.5	15.2	11.0	6.1	1.6	5.0	3.35	1.4	4.4	4.3	2.8	5.2	2.4	1.26	7.2
2 1/2	(N)ERG025SD	26.8	11.0	15.7	12.8	6.2	1.6	5.8	3.94	1.4	5.3	4.5	3.1	6.0	2.7	1.42	7.2
3	(N)ERG030LD*	30.3	11.0	15.7	12.8	6.2	1.7	5.8	3.94	1.4	5.3	4.5	3.1	6.0	2.7	1.42	7.2
3	(N)ERG030CD	32.7	11.0	15.7	12.8	6.2	1.8	5.8	3.94	1.4	5.3	4.5	3.1	6.0	2.7	1.42	7.2
5	(N)ERG050LD	33.1	11.5	15.8	15.7	6.2	1.9	6.7	4.65	1.8	5.6	5.1	3.2	7.0	3.4	2.13	7.2

*The (N)ERG030LD listed is the previous hoist model. Refer to Harrington catalog C-EPH for features and benefits.
Speed ratio is 6:1 with adjustability up to 12:1.