

NERM/ERM Electric Chain Hoists with Motorized Trolleys



NERM/ERM020L-L/S
(Shown with optional
canvas chain container)

The MR Series of electric trolleys further expand the capabilities of our NER/ER line of electric hoists. These trolleys feature an innovative side guide roller system that results in very smooth travel along the beam.

Features and Benefits

UL® Listed**

Certified and listed to UL 1340 "Standard for Hoists."

Easy Access Suspension

External pins allow for quick change from hook to lug for trolley mount configurations on most models.

Perpendicular Orientation

MR motorized trolley mount hoists are configured as perpendicular to the beam. Parallel mount is available as an option.

Green Initiative

Built smarter without the use of harmful materials. Environmentally friendly. RoHS compliant.

Notched Hook and Latch System

Provides positive closing and improves resistance against lateral forces.

High Air Flow

Cooler motor and brake attributed to an engineered motor fin, fan blade and fan cover design.

Unique Load Sheave

Increased number of pockets reduce chain vibration and increase chain life. 5 pockets standard; 6 pockets on smaller body hoists.

Extended Chain Life

Decreased chain wear as a result of a revolutionary heat treatment process, improved material and chain size.

Limit Switches

Low-profile upper and lower limit switches are standard.

Contactors

Mechanically interlocked, heavy-duty contactors on single speed models.

Friction Clutch and Load Brake

Friction clutch is standard on NER/ER models and friction clutch with mechanical load brake standard on ER models. Carbon friction material provides consistent performance over a wide temperature range.

High Strength, Corrosion and Wear Resistant Load Chain

Grade 80, super strength, nickel-plated load chain, certified to DIN standards, uses unique technology to greatly increase resistance to fatigue and wear.

Standard Count Hour Meter

Records and displays the number of lowering starts and hoist on time which is valuable for preventive maintenance. Integral to VFD on dual speed models.

Dual Speed VFD

Under-the-cover VFD standard for dual speed hoists and trolleys. Hoist speed ratio is 6:1 with adjustability up to 12:1. Trolley speed ratio is 6:1 with adjustability up to 10:1.

"The Guardian": Smart Brake Technology

A current driven electromagnetic brake does not release unless the motor is energized. 10 year hoist brake warranty.

Pendant Controls

Ergonomic design for operator comfort. Red button emergency stop is standard on all 4-button pendants.

Standard Motorized Trolley Specifications

Capacity Range

1/8 Ton – 5 Ton
(See page 34 for 8 – 20 Ton)

Standard Voltage

208-230/460-3-60
Optional voltages available
Dual speed models are not reconnectable

Control Voltage

110V (optional 24V)

Duty Cycle*

Single Speed – 30 Min.
Dual Speed – 30/10 Min. with VFD

Classification*

ASME H4
ISO M5 or M4
FEM 2m or 1Am

Ratings

Trolley – IP55
Pendant – IP65

Standard Pendants

4-button (momentary contacts) with emergency on/off (maintained contacts)

Shafts

Standard shafts fit wide flange range
Longer shafts for wider beams
Spacers for easy adjustments

Drop Stops

Standard

Bumpers

Standard

Wheels

All steel
Shielded ball bearings
Fit flat or tapered beam flange

Standard Power Supply Length

30' (longer lengths available)

Standard Pendant Drop

Standard pendant hangs approximately 4' above the hoist's fully extended bottom hook (longer lengths available)

*See page 79-81 for additional information.

**Most models shipped with UL listing. Contact Customer Service for listed models.

The 3 Ton (N)ERM030L is the previous hoist model.

HARRINGTON ELECTRIC CHAIN HOISTS



NERM/ERM020L-L/S
(Shown with optional
canvas chain container)

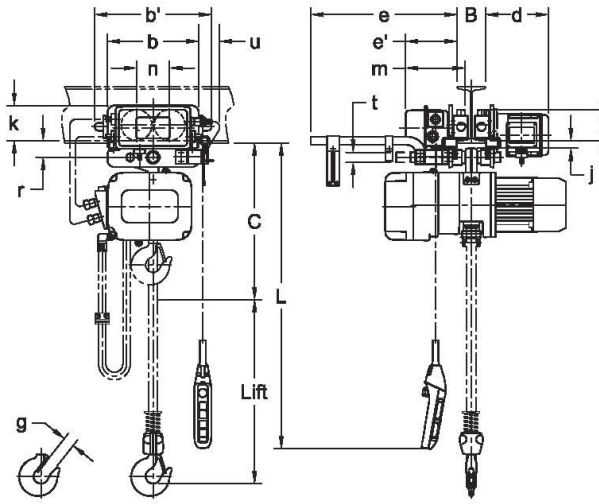

NERM/ERM020L-L/S

SINGLE SPEED HOIST WITH SINGLE SPEED TROLLEY — SPECIFICATIONS

Cap. (Tons)	Product Code	Std. Lift (ft)	Push Button Cord L (ft)	Lifting Speed (ft/min)	Traversing Speed (ft/min)	Lifting Motor 3 Phase 60 Hz			Traversing Motor 3 Phase 60 Hz			Flange Width Adjustability B (in)		Minimum Allow. Radius for Curve (in)	Load Chain Diameter (mm) x Chain Fall Lines	Net Weight (lbs)		Weight for Additional One Foot of Lift (lbs)	
						Output (Hp)	Rated Current (amps) @208-230V @460V		Output (Hp)	Rated Current (amps) @208-230V @460V		Standard	Optional			NER	ER		
1/8	(N)ERM001H-L/S	10	8.2	55	L = 40 S = 80	0.75	3.4	1.7	0.54	3.2	1.6	2.28 to 5.00	5.01 to 6.02 OR 6.03 to 12.00	31.5**	4.3 x 1	128	130	0.28	
1/4	(N)ERM003S-L/S			36		0.75	3.4	1.7	0.54	3.2	1.6				4.3 x 1	128	130	0.28	
1/4	(N)ERM003H-L/S			53		1.2	4.8	2.5	0.54	3.2	1.6				6.0 x 1	148	150	0.54	
1/2	(N)ERM005L-L/S			15		0.75	3.4	1.7	0.54	3.2	1.6				6.0 x 1	139	146	0.54	
1/2	(N)ERM005S-L/S			29		1.2	4.8	2.5	0.54	3.2	1.6				6.0 x 1	148	150	0.54	
1	(N)ERM010L-L/S			14		1.2	4.8	2.5	0.54	3.2	1.6				7.7 x 1	170	176	0.89	
1	(N)ERM010S-L/S			28		2.4	8.6	4.2	0.54	3.2	1.6	7.7 x 1	185	185	0.89				
1 1/2	(N)ERM015S-L/S			18		2.4	8.6	4.2	0.54	3.2	1.6	3.23 to 6.02	6.03 to 7.02 OR 7.03 to 12.00	31.5†	10.2 x 1	243	254	1.6	
2	(N)ERM020C-L/S			7		1.2	4.8	2.5	0.54	3.2	1.6				7.7 x 2	214	218	1.8	
2	(N)ERM020L-L/S			14		2.4	8.6	4.2	0.54	3.2	1.6				10.2 x 1	245	256	1.6	
2	(N)ERM020S-L/S			28		4.7	16.4	7.9	0.54	3.2	1.6				10.2 x 1	284	282	1.6	
2 1/2	(N)ERM025S-L/S			22		4.7	16.4	7.9	0.54	3.2	1.6				39.4	11.2 x 1	333	331	1.9
3	(N)ERM030L-L/S*			16		4.7	18.3	9.2	0.5	3.2	1.6					12.5 x 1	362	362	2.3
3	(N)ERM030C-L/S			17		4.7	16.4	7.9	0.54	3.2	1.6	10.2 x 2	340	340		3.2			
5	(N)ERM050L-L/S	9.2	11	4.7	16.4	7.9	1.0	5.1	2.5	3.94 to 7.01	7.02 to 7.60 OR 7.61 to 12.00	70.9	11.2 x 2	443	439	3.8			

*The (N)ERM030L-L/S listed is the previous hoist model. Refer to Harrington catalog C-EPH for features and benefits.

**Flange widths smaller than 4 inches will have a minimum radius of 137.8 inches.

†Flange widths smaller than 5 inches will have a minimum radius of 39.4 inches.

NERM/ERM Electric Chain Hoists with Motorized Trolleys



NERM/ERM020L-L/S
(Shown with optional
canvas chain container)

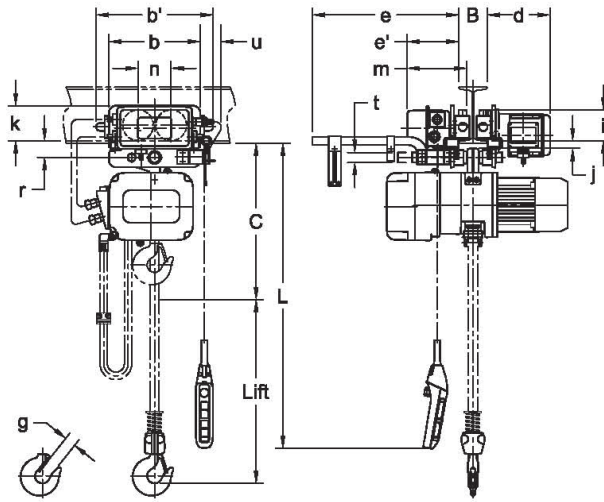

NERM/ERM020L-L/S

SINGLE SPEED HOIST WITH SINGLE SPEED TROLLEY — DIMENSIONS

Cap. (Tons)	Product Code	Headroom C (in)	b (in)	b' (in)	d (in)	e (in)	e' (in)	g (in)	i (in)	j (in)	k (in)	m (in)	n (in)	r (in)	t (in)	u (in)
1/8	(N)ERM001H-L/S	14.8	12.4	15.6	8.7	20.3	7.1	1.1	3.74	0.9	5.1	8.1	4.3	2.0	1.22	3.3
1/4	(N)ERM003S-L/S	14.8	12.4	15.6	8.7	20.3	7.1	1.1	3.74	0.9	5.1	8.1	4.3	2.0	1.22	3.3
1/4	(N)ERM003H-L/S	15.6	12.4	15.6	8.7	20.3	7.1	1.1	3.74	0.9	5.1	8.1	4.3	2.0	1.22	3.3
1/2	(N)ERM005L-L/S	15.6	12.4	15.6	8.7	20.3	7.1	1.1	3.74	0.9	5.1	8.1	4.3	2.0	1.22	3.3
1/2	(N)ERM005S-L/S	15.6	12.4	15.6	8.7	20.3	7.1	1.1	3.74	0.9	5.1	8.1	4.3	2.0	1.22	3.3
1	(N)ERM010L-L/S	17.1	12.4	15.6	8.7	20.3	7.1	1.2	3.74	0.9	5.1	8.1	4.3	2.0	1.22	3.3
1	(N)ERM010S-L/S	17.1	12.4	15.6	8.7	20.3	7.1	1.2	3.74	0.9	5.1	8.1	4.3	2.0	1.22	3.3
1 1/2	(N)ERM015S-L/S	19.9	12.8	16.4	8.8	20.5	7.3	1.4	4.33	1.1	4.9	8.3	4.6	2.4	1.42	3.0
2	(N)ERM020C-L/S	27.2	12.8	16.4	8.8	20.5	7.3	1.5	4.33	1.1	4.9	8.3	4.6	2.4	1.42	3.0
2	(N)ERM020L-L/S	22.4	12.8	16.4	8.8	20.5	7.3	1.6	4.33	1.1	4.9	8.3	4.6	2.4	1.42	3.0
2	(N)ERM020S-L/S	23.0	12.8	16.4	8.8	20.5	7.3	1.6	4.33	1.1	4.9	8.3	4.6	2.4	1.42	3.0
2 1/2	(N)ERM025S-L/S	24.4	13.4	17.4	8.9	20.5	7.3	1.6	4.92	1.1	5.2	8.5	5.2	2.7	1.69	2.8
3	(N)ERM030L-L/S*	25.4	13.4	17.4	8.9	20.5	7.3	1.7	4.92	1.1	5.2	8.5	5.2	2.7	1.69	2.7
3	(N)ERM030C-L/S	32.9	13.4	17.4	8.9	20.5	7.3	1.8	4.92	1.1	5.2	8.5	5.2	2.7	1.69	2.8
5	(N)ERM050L-L/S	33.1	15.7	19.8	11.0	20.8	7.6	1.9	5.51	1.7	5.7	9.2	5.9	3.4	2.13	2.2

*The (N)ERM030L-L/S listed is the previous hoist model. Refer to Harrington catalog C-EPH for features and benefits.



NERM/ERM020LD-L/S
(Shown with optional
canvas chain container)

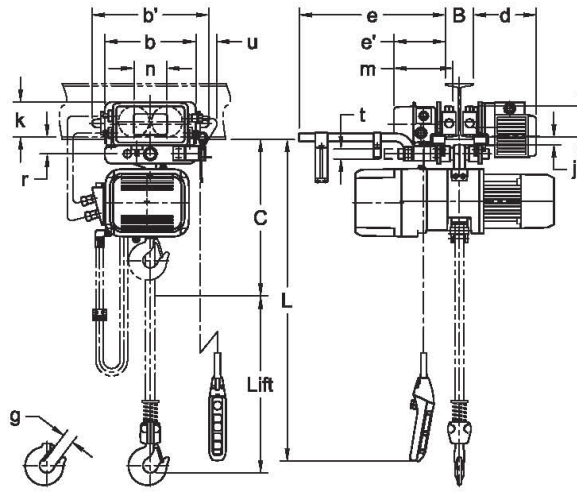

NERM/ERM020LD-L/S

DUAL SPEED HOIST WITH SINGLE SPEED TROLLEY — SPECIFICATIONS

Cap. (Tons)	Product Code	Std. Lift (ft)	Push Button Cord L (ft)	Lifting Speed (ft/min)	Traversing Speed (ft/min)	Lifting Motor [†] 3 Phase 60 Hz			Traversing Motor 3 Phase 60 Hz			Flange Width Adjustability B (in)		Minimum Allow. Radius for Curve (in)	Load Chain Diameter (mm) x Chain Fall Lines	Net Weight (lbs)		Weight for Additional One Foot of Lift (lbs)
						Output (Hp)	Rated Current (amps)		Output (Hp)	Rated Current (amps)		Standard	Optional			NER	ER	
1/8	(N)ERM001HD-L/S	10	8.2	55/9	L = 40 S = 80	0.75	3.6	1.8	0.54	3.2	1.6	2.28 to 5.00	5.01 to 6.02 OR 6.03 to 12.00	31.5**	4.3 x 1	128	132	0.28
1/4	(N)ERM003SD-L/S			36/6		0.75	3.6	1.8	0.54	3.2	1.6				4.3 x 1	128	132	0.28
1/4	(N)ERM003HD-L/S			53/9		1.2	5.1	2.7	0.54	3.2	1.6				6.0 x 1	146	150	0.54
1/2	(N)ERM005LD-L/S			15/2.5		0.75	3.6	1.8	0.54	3.2	1.6				6.0 x 1	137	146	0.54
1/2	(N)ERM005SD-L/S			29/5		1.2	5.1	2.7	0.54	3.2	1.6				6.0 x 1	146	150	0.54
1	(N)ERM010LD-L/S			14/2.5		1.2	5.1	2.7	0.54	3.2	1.6				7.7 x 1	166	174	0.89
1	(N)ERM010SD-L/S			28/4.5		2.4	9.1	4.5	0.54	3.2	1.6				7.7 x 1	181	183	0.89
1 1/2	(N)ERM015SD-L/S			18/3		2.4	9.1	4.5	0.54	3.2	1.6	3.23 to 6.02	6.03 to 7.02 OR 7.03 to 12.00	31.5 [†]	10.2 x 1	243	256	1.6
2	(N)ERM020CD-L/S			7/1		1.2	5.1	2.7	0.54	3.2	1.6				7.7 x 2	207	216	1.8
2	(N)ERM020LD-L/S			14/2.5		2.4	9.1	4.5	0.54	3.2	1.6				10.2 x 1	245	256	1.6
2	(N)ERM020SD-L/S			28/4.5		4.7	17.3	8.3	0.54	3.2	1.6				10.2 x 1	280	286	1.6
2 1/2	(N)ERM025SD-L/S			22/3.5		4.7	17.3	8.3	0.54	3.2	1.6				11.2 x 1	324	338	1.9
3	(N)ERM030LD-L/S*			17/6		4.7/1.6	19.6/9.4	9.8/4.7	0.5	3.2	1.6				12.5 x 1	406	406	2.3
3	(N)ERM030CD-L/S			17/3		4.7	17.3	8.3	0.54	3.2	1.6				10.2 x 2	336	344	3.2
5	(N)ERM050LD-L/S	9.2	11/2	4.7	17.3	8.3	1.0	5.1	2.5	3.94 to 7.01	7.02 to 7.60 OR 7.61 to 12.00	70.9	11.2 x 2	434	448	3.8		

*The (N)ERM030LD-L/S listed is the previous hoist model. Refer to Harrington catalog C-EPH for features and benefits.

**Flange widths smaller than 4 inches will have a minimum radius of 137.8 inches.

†Flange widths smaller than 5 inches will have a minimum radius of 39.4 inches.

‡ Although both 208/230 & 460 Volts are shown together, the motors are NOT reconnectable.

Speed ratio is 6:1 with adjustability up to 12:1.

NERM/ERM Electric Chain Hoists with Motorized Trolleys



NERM/ERM020LD-L/S
(Shown with optional
canvas chain container)

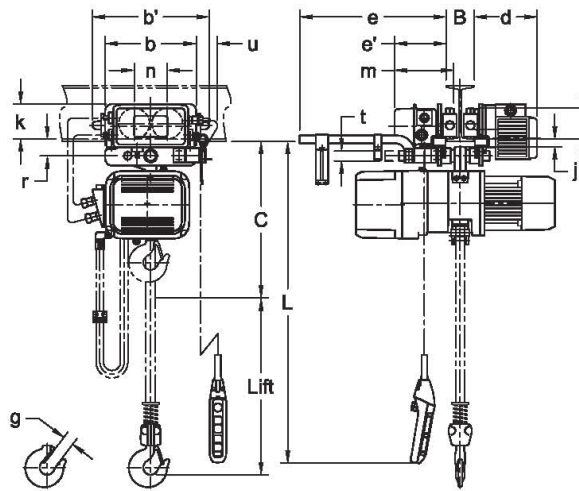

NERM/ERM020LD-L/S

DUAL SPEED HOIST WITH SINGLE SPEED TROLLEY — DIMENSIONS

Cap. (Tons)	Product Code	Headroom C (in)	b (in)	b' (in)	d (in)	e (in)	e' (in)	g (in)	i (in)	j (in)	k (in)	m (in)	n (in)	r (in)	t (in)	u (in)
1/8	(N)ERM001HD-L/S	14.8	12.4	15.6	8.7	20.3	7.1	1.1	3.74	0.9	5.1	8.1	4.3	2.0	1.22	3.3
1/4	(N)ERM003SD-L/S	14.8	12.4	15.6	8.7	20.3	7.1	1.1	3.74	0.9	5.1	8.1	4.3	2.0	1.22	3.3
1/4	(N)ERM003HD-L/S	15.6	12.4	15.6	8.7	20.3	7.1	1.1	3.74	0.9	5.1	8.1	4.3	2.0	1.22	3.3
1/2	(N)ERM005LD-L/S	15.6	12.4	15.6	8.7	20.3	7.1	1.1	3.74	0.9	5.1	8.1	4.3	2.0	1.22	3.3
1/2	(N)ERM005SD-L/S	15.6	12.4	15.6	8.7	20.3	7.1	1.1	3.74	0.9	5.1	8.1	4.3	2.0	1.22	3.3
1	(N)ERM010LD-L/S	17.1	12.4	15.6	8.7	20.3	7.1	1.2	3.74	0.9	5.1	8.1	4.3	2.0	1.22	3.3
1	(N)ERM010SD-L/S	17.1	12.4	15.6	8.7	20.3	7.1	1.2	3.74	0.9	5.1	8.1	4.3	2.0	1.22	3.3
1 1/2	(N)ERM015SD-L/S	19.9	12.8	16.4	8.8	20.5	7.3	1.4	4.33	1.1	4.9	8.3	4.6	2.4	1.42	3.0
2	(N)ERM020CD-L/S	27.2	12.8	16.4	8.8	20.5	7.3	1.5	4.33	1.1	4.9	8.3	4.6	2.4	1.42	3.0
2	(N)ERM020LD-L/S	22.4	12.8	16.4	8.8	20.5	7.3	1.6	4.33	1.1	4.9	8.3	4.6	2.4	1.42	3.0
2	(N)ERM020SD-L/S	23.0	12.8	16.4	8.8	20.5	7.3	1.6	4.33	1.1	4.9	8.3	4.6	2.4	1.42	3.0
2 1/2	(N)ERM025SD-L/S	24.4	13.4	17.4	8.9	20.5	7.3	1.6	4.92	1.1	5.2	8.5	5.2	2.7	1.69	2.8
3	(N)ERM030LD-L/S*	28.0	13.4	17.4	8.9	20.5	7.3	1.7	4.92	1.1	5.2	8.5	5.2	2.7	1.69	2.7
3	(N)ERM030CD-L/S	32.9	13.4	17.4	8.9	20.5	7.3	1.8	4.92	1.1	5.2	8.5	5.2	2.7	1.69	2.8
5	(N)ERM050LD-L/S	33.1	15.7	19.8	11.0	20.8	7.6	1.9	5.51	1.7	5.7	9.2	5.9	3.4	2.13	2.2

*The (N)ERM030LD-L/S listed is the previous hoist model. Refer to Harrington catalog C-EPH for features and benefits.
Speed ratio is 6:1 with adjustability up to 12:1.



NERM/ERM020LD-SD
(Shown with optional
canvas chain container)

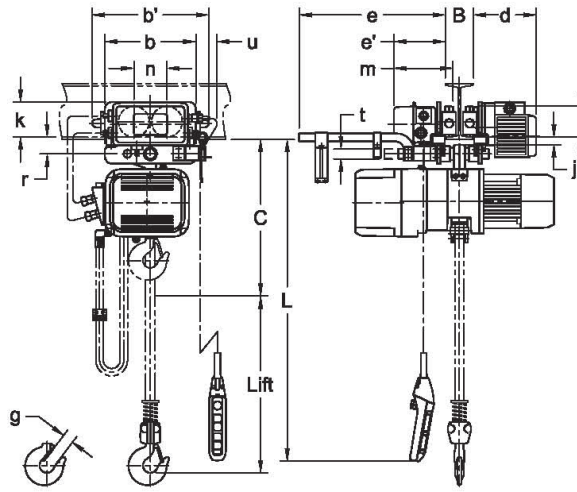

NERM/ERM020LD-SD

DUAL SPEED HOIST WITH DUAL SPEED TROLLEY — SPECIFICATIONS

Cap. (Tons)	Product Code	Std. Lift (ft)	Push Button Cord L (ft)	Lifting Speed (ft/min)	Traversing Speed (ft/min)	Lifting Motor† 3 Phase 60 Hz			Traversing Motor† 3 Phase 60 Hz			Flange Width Adjustability B (in)		Minimum Allow. Radius for Curve (in)	Load Chain Diameter (mm) x Chain Fall Lines	Net Weight (lbs)		Weight for Additional One Foot of Lift (lbs)	
						Output (Hp)	@208-230V	@460V	Output (Hp)	@208-230V	@460V	Standard	Optional			NER	ER		
1/8	(N)ERM001HD-SD	10	8.2	55/9	80/13	0.75	3.6	1.8	0.54	3.4	1.7	2.28 to 5.00	5.01 to 6.02 OR 6.03 to 12.00	31.5**	4.3 x 1	130	135	0.28	
1/4	(N)ERM003SD-SD			36/6		0.75	3.6	1.8	0.54	3.4	1.7				4.3 x 1	130	135	0.28	
1/4	(N)ERM003HD-SD			53/9		1.2	5.1	2.7	0.54	3.4	1.7				6.0 x 1	150	154	0.54	
1/2	(N)ERM005LD-SD			15/2.5		0.75	3.6	1.8	0.54	3.4	1.7				6.0 x 1	141	150	0.54	
1/2	(N)ERM005SD-SD			29/5		1.2	5.1	2.7	0.54	3.4	1.7				6.0 x 1	150	154	0.54	
1	(N)ERM010LD-SD			14/2.5		1.2	5.1	2.7	0.54	3.4	1.7				7.7 x 1	170	179	0.89	
1	(N)ERM010SD-SD			28/4.5		2.4	9.1	4.5	0.54	3.4	1.7	7.7 x 1	185	187	0.89				
1 1/2	(N)ERM015SD-SD			18/3		2.4	9.1	4.5	0.54	3.4	1.7	3.23 to 6.02	6.03 to 7.02 OR 7.03 to 12.00	31.5†	10.2 x 1	245	260	1.6	
2	(N)ERM020CD-SD			7/1		1.2	5.1	2.7	0.54	3.4	1.7				7.7 x 2	214	223	1.8	
2	(N)ERM020LD-SD			14/2.5		2.4	9.1	4.5	0.54	3.4	1.7				10.2 x 1	247	262	1.6	
2	(N)ERM020SD-SD			28/4.5		4.7	17.3	8.3	0.54	3.4	1.7				10.2 x 1	284	291	1.6	
2 1/2	(N)ERM025SD-SD			22/3.5		4.7	17.3	8.3	0.54	3.4	1.7				39.4	11.2 x 1	331	344	1.9
3	(N)ERM030LD-SD*			17/6		4.7/1.6	19.6/9.4	9.8/4.7	0.9/0.2	3.6/3.1	1.8/1.6					12.5 x 1	412	412	2.3
3	(N)ERM030CD-SD			17/3		4.7	17.3	8.3	0.54	3.4	1.7	10.2 x 2	340	351		3.2			
5	(N)ERM050LD-SD	9.2	11/2	4.7	17.3	8.3	1.0	5.4	2.7	3.94 to 7.01	7.02 to 7.60 OR 7.61 to 12.00	70.9	11.2 x 2	439	452	3.8			

*The (N)ERM030LD-SD listed is the previous hoist model. Refer to Harrington catalog C-EPH for features and benefits.

**Flange widths smaller than 4 inches will have a minimum radius of 137.8 inches.

†Flange widths smaller than 5 inches will have a minimum radius of 39.4 inches.

‡Although both 208/230 & 460 Volts are shown together, the motors are NOT reconnectable.

Hoist speed ratio is 6:1 with adjustability up to 12:1.

Trolley speed ratio is 6:1 with adjustability up to 10:1.

NERM/ERM Electric Chain Hoists with Motorized Trolleys



NERM/ERM020LD-SD
(Shown with optional
canvas chain container)

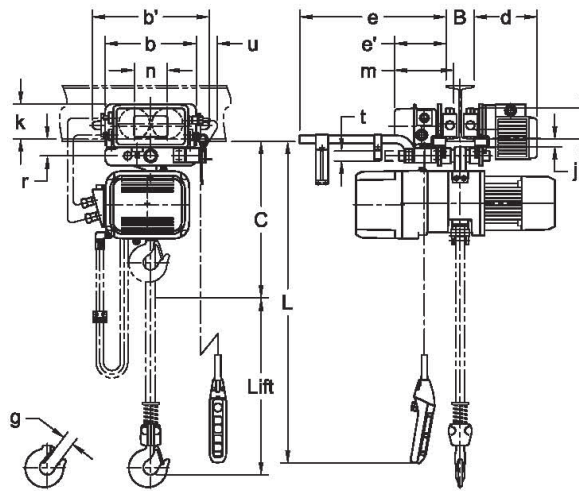

NERM/ERM020LD-SD

DUAL SPEED HOIST WITH DUAL SPEED TROLLEY — DIMENSIONS

Cap. (Tons)	Product Code	Headroom C (in)	b (in)	b' (in)	d (in)	e (in)	e' (in)	g (in)	i (in)	j (in)	k (in)	m (in)	n (in)	r (in)	t (in)	u (in)
1/8	(N)ERM001HD-SD	14.8	12.4	15.6	8.7	20.3	7.1	1.1	3.74	0.9	5.1	8.1	4.3	2.0	1.22	3.3
1/4	(N)ERM003SD-SD	14.8	12.4	15.6	8.7	20.3	7.1	1.1	3.74	0.9	5.1	8.1	4.3	2.0	1.22	3.3
1/4	(N)ERM003HD-SD	15.6	12.4	15.6	8.7	20.3	7.1	1.1	3.74	0.9	5.1	8.1	4.3	2.0	1.22	3.3
1/2	(N)ERM005LD-SD	15.6	12.4	15.6	8.7	20.3	7.1	1.1	3.74	0.9	5.1	8.1	4.3	2.0	1.22	3.3
1/2	(N)ERM005SD-SD	15.6	12.4	15.6	8.7	20.3	7.1	1.1	3.74	0.9	5.1	8.1	4.3	2.0	1.22	3.3
1	(N)ERM010LD-SD	17.1	12.4	15.6	8.7	20.3	7.1	1.2	3.74	0.9	5.1	8.1	4.3	2.0	1.22	3.3
1	(N)ERM010SD-SD	17.1	12.4	15.6	8.7	20.3	7.1	1.2	3.74	0.9	5.1	8.1	4.3	2.0	1.22	3.3
1 1/2	(N)ERM015SD-SD	19.9	12.8	16.4	8.8	20.5	7.3	1.4	4.33	1.1	4.9	8.3	4.6	2.4	1.42	3.0
2	(N)ERM020CD-SD	27.2	12.8	16.4	8.8	20.5	7.3	1.5	4.33	1.1	4.9	8.3	4.6	2.4	1.42	3.0
2	(N)ERM020LD-SD	22.4	12.8	16.4	8.8	20.5	7.3	1.6	4.33	1.1	4.9	8.3	4.6	2.4	1.42	3.0
2	(N)ERM020SD-SD	23.0	12.8	16.4	8.8	20.5	7.3	1.6	4.33	1.1	4.9	8.3	4.6	2.4	1.42	3.0
2 1/2	(N)ERM025SD-SD	24.4	13.4	17.4	8.9	20.5	7.3	1.6	4.92	1.1	5.2	8.5	5.2	2.7	1.69	2.8
3	(N)ERM030LD-SD*	28.0	13.4	17.4	10.8	20.5	7.3	1.7	4.92	1.1	5.2	8.5	5.2	2.7	1.69	2.7
3	(N)ERM030CD-SD	32.9	13.4	17.4	8.9	20.5	7.3	1.8	4.92	1.1	5.2	8.5	5.2	2.7	1.69	2.8
5	(N)ERM050LD-SD	33.1	15.7	19.8	11.0	20.8	7.6	1.9	5.51	1.7	5.7	9.2	5.9	3.4	2.13	2.2

*The (N)ERM030LD-SD listed is the previous hoist model. Refer to Harrington catalog C-EPH for features and benefits.

Hoist speed ratio is 6:1 with adjustability up to 12:1.

Trolley speed ratio is 6:1 with adjustability up to 10:1.

MR Motorized Trolleys

Pull-Rotor Motor Brake

Extremely durable and reliable, this advanced design furnishes precision load control, deceleration and long life.

Heavy-Duty Motor

Designed for top performance with high-horsepower, 30-minute duty rating, cooling fins and standard thermal motor protection. Motor is totally enclosed, non-ventilated (TENV).

Variable Frequency Drive

Dual speed controls via “under-the-cover” variable frequency drive standard.

Sealed Protection

Appropriate for both indoor and outdoor applications, including harsh environments. (Consult owner’s manuals for details.) Gaskets throughout the trolley provide for an IP55 rating.

Built-In Drop Stops

Important feature provides additional security for the operator and the equipment.

Rubber Bumpers

Standard feature on all motorized trolleys. Provides protection from collisions. Complies with ASME standards.

Side Guide Rollers

Four ball bearing supported rollers enhance smooth trolley motion and reduce wear of the wheels and beam.

Cable Support Arm Assembly

Convenient “tow bar” is standard component that gives support and guides the power supply festooning.

Pendant Plug-In Connections

Saves valuable time on setup and maintenance. “Quick disconnect” replaces typical competitive hard-wired designs.

