

# JBC SERIES BEAM CLAMP USER MANUAL



**ELEPHANT**  
LIFTING PRODUCTS™

This operation manual edition 06/2017 covers Elephant Lifting Products Jumbo Beam Clamps:

It must be read carefully and in its entirety before operating any jumbo beam clamp.

Serial No.
------------

Please enter the Serial No. of your Elephant Lifting Products jumbo beam clamp here.

**THIS MANUAL MUST BE READ BEFORE USING THESE PRODUCTS.**

This manual contains important safety, installation, operation, and maintenance and repair information. Make this manual available to all persons responsible for the operation, installation, maintenance and repair of these products.

**Do not use this clamp for lifting, supporting, or transporting people or lifting or supporting loads over people.**

It is the responsibility of the owner/user to install, inspect, test, maintain, and operate a clamp in accordance with ANSI/ASME B30.20, "Safety Standard for Below-the-Hook-Lifting-Devices", OSHA regulations. If the jumbo beam clamp is installed as part of a total lifting system, such as an overhead crane or monorail, it is also the responsibility of the owner/user to comply with the applicable ANSI/ASME B30 volume that addresses that type of equipment, it must also be read by all personnel.

If the jumbo beam clamp owner/user requires additional information, or if any information in the manual is not clear, contact Elephant Lifting Products or the distributor of the jumbo beam clamp. Do not install, inspect, test, maintain, or operate this jumbo beam clamp unless this information is fully understood.

A regular schedule of inspection of the jumbo beam clamp in accordance with the requirements of ANSI/ASME B30.20 should be established and records maintained.

Preface .....	2
Safety Information .....	3
1 Identification .....	5
2 Product Description .....	5
2.1 Main Components .....	5
3 Intended Use .....	6
4 Operating Conditions.....	6
5 Transport and Storage .....	6
5.1 Safe Transportation .....	6
5.2 Breaks in Operation .....	6
5.3 Storage.....	6
6 Initial Operation .....	6
6.1 Installation of the Jumbo Beam Clamp .....	7
6.2 Lubrication .....	7
7 Inspection .....	7
7.1 Initial Inspection .....	8
7.2 Every Lift Inspection .....	8
7.3 Frequent Inspection.....	8
7.4 Periodic Inspection .....	8
7.5 Daily Inspection for Machines Operated in Corrosive Environments.....	8
7.6 Jumbo Beam Clamp Not in Regular Use.....	8
8 Operation.....	8
8.1 Rules for the Safe Operation of JBC .....	8
8.2 Operating Limits of the Jumbo Beam Clamp..	9
9 Maintenance.....	9
9.1 Maintenance and Inspection Intervals .....	9
9.2 Cleaning and Care .....	9
9.3 Spare Parts.....	9
10 Technical Data.....	10

## **Preface**

Elephant Lifting Products warrants to the user its jumbo beam clamps, and other products to be free from defects in material and workmanship for a period of one year from the date of purchase.

Elephant Lifting Products will repair, without cost to the user, any product found to be defective, including parts and labor charges, or at Elephant Lifting Products 's option, will replace such products or refund the purchase price less a reasonable allowance for handling in exchange for the product. Repair and replacements are warranted for the remainder of the original warranty period.

If any product proves defective within its original one year warranty period, it shall be returned to Elephant Lifting Products with proof of purchase and the original test certificate.

This warranty does not apply to products which Elephant Lifting Products has determined to have been misused or abused, improperly maintained by the user, or where the malfunction or defect can be attributed to the use of non-genuine Elephant Lifting Products parts.

Elephant Lifting Products makes no other warranty and its maximum liability is limited to the purchase price of the product and in no event will Elephant Lifting Products be liable for any consequential, indirect, incidental or special damages of any nature arising from the sale or use of the product whether based on contract or otherwise.

It is Elephant Lifting Products policy to promote safety of all persons and equipment in the workplace. All equipment manufactured is thoroughly checked, packed and inspected before dispatch. Any loss or damage which occurs during shipment while en-route must be reported to Elephant Lifting Products immediately. Should any item be delivered to you in apparent good condition, but upon opening the container, loss or damage has taken place while in transit; notify Elephant Lifting Products immediately. Should any items be delivered back to Elephant Lifting Products all transport costs will be for the account of the user.

These instructions are prepared by Elephant Lifting Products for the purpose of maintenance.

No responsibility for failure of equipment due to manufacturing procedure will be assumed if these instructions are not carried out.

## Safety Information

This manual will refer to existing legal requirements and engineering practices as known when this document was written. Should any such legislation or practices change or be “enlarged” upon then due consideration must be taken. Various standards have been used to assist in compiling this document and will be listed where applicable.

The use of powerful lifting equipment is subject to certain hazards that cannot be overcome by mechanical means but only by the exercise of intelligence, care and common sense. It is therefore essential that personnel involved in the use and operation of equipment must be competent, careful, physically and mentally qualified, and trained in the safe operation of equipment and the handling of the loads. Serious hazards include but are not limited to are overloading, dropping or slipping of the load caused by improper hitching or slinging, obstructing the free passage of the load and using equipment for a purpose for which it was not intended or designed. The above can lead to fatal consequences.

Operators of Elephant Lifting Products Jumbo Beam Clamps are also under obligation to ensure safe and hazard-free operation. This can be achieved through the following measures:

- Keep the operation manuals available at the beam clamp operating site,
- Performing regular training,
- Performing regular inspections (at least once annually),
- Implement an inspection log and make regular entries,
- And regularly check personnel for safety and hazard awareness during work.

Elephant Lifting Products fully realizes the importance of proper design factors, minimum and maximum sizes and other limiting dimensions of the structural components of the clamp, all of which are designed with safety in mind.

The various conditions of the equipment or material can vary depending on the environment they are used in which may cause corrosion or wear and any other variables that may arise in each individual application. It is in the light of this that the jumbo beam clamp be maintained and repaired under the supervision of a competent person:

- 1) Who is qualified by virtue of his knowledge, training, skills and experience to organize the work and its performance;
- 2) Who is familiar with the legal requirements which apply to the work to be performed;
- 3) Who has been trained to recognize any potential or actual danger to health and safety in the performance of the work.

The instructions given in this manual must be interpreted accordingly and sound judgment used in determining their application.

This operation manual is intended to help the operator to become familiar with Elephant Lifting Products jumbo beam clamps and how to use them properly.

This operation manual contains important information for the safe, proper and efficient operation of Elephant Lifting Products jumbo beam clamps. Observance of the manual helps to avoid hazardous situations, to reduce repair costs and downtimes and to ensure the specified service life of the Elephant Lifting Products Jumbo Beam Clamps.

**Always keep the manual readily available at the location where the Elephant Lifting Products jumbo beam clamp is being used.**

**All persons charged with operating, maintaining or repairing Elephant Lifting Products jumbo beam clamp must read and follow the instructions in this manual.**

### **Danger, Warning, Caution and Notice**

Throughout this manual there are steps and procedures which, if not followed, may result in an injury. The following signal words are used to identify the level of potential hazard.

Danger is used to indicate the presence of hazard which will cause **severe** injury, death or substantial property damage if the warning is ignored.

**DANGER**

Warning is used to indicate the presence of a hazard which **can** cause **severe** injury, death, or substantial property damage if the warning is ignored.

**WARNING**

Caution is used to indicate the presence of a hazard which **will** or **can** cause minor injury or property damage if the warning is ignored.

**CAUTION**

Notice is used to notify people of installation, operation, or maintenance information which are important but not hazard-related.

**NOTICE**

## Safety Summary

### WARNING

- Do not use this jumbo beam clamp or any equipment attached to it for lifting, supporting, or transporting people or lifting or supporting loads over people.
- Elephant Lifting Products JBC series of beam clamps are designed to provide a MINIMUM of 5 to 1 safety factor. It is the responsibility of the customer to ensure that the structure to which the jumbo beam clamp is attached and any load attaching devices are capable of handling the static and dynamic loads imposed on the structure by the jumbo beam clamp and its attachments when lifting the rated load. If in doubt, consult a registered professional structural engineer.

### NOTICE

- Lifting equipment is subject to different regulations in each country. These regulations may not be specified in this manual.
- Whenever a conflict arises between the contents of this manual and any other applicable legislation, standard or procedure, the more stringent of the two must be applied.

The Occupational Health and Safety Act and Mine Health and Safety Act and other recognized safety sources make a common point: Employees who work near cranes or assist in hooking on or arranging a load should be instructed to keep out from under the load.

From a safety standpoint, one factor is paramount: conduct all lifting operations in such a manner that if there were an equipment failure, no personnel would be injured. This means keep out from under a raised load and keep out of the intended path of any load.

It is the owner's and user's responsibility to determine the suitability of a product for any particular use. It is recommended that all applicable industry, trade association and legislation be checked. Read all operation instructions and warnings before operation.

This manual has been produced by **Elephant Lifting Products** to provide agents, fitters, and company personnel with the information required to install, operate, maintain and repair the products described herein.

It is extremely important that fitters and operators be familiar with the servicing procedures of these products, or similar products, and is physically capable of conducting the procedures. These personnel shall have a general working knowledge that includes:

- 1) Proper and safe use and application of fitter's common hand tools as well as special or recommended tools.
- 2) Safety procedures, precautions and work habits established by accepted industry standards.
- 3) Elephant Lifting Products cannot know of, nor provide all the procedures by which product operations or repairs may be conducted and the hazards and/or results of each method. Operation or maintenance procedures not specifically recommended by the manufacturer are conducted, it must be ensured that product safety is not endangered by the actions taken. If unsure of an operation or maintenance procedure or step, personnel should place the product in a safe condition and contact supervisors and/or the factory for technical assistance.

## 1 Identification

The nameplate mounted on the side plate identifies the type of Elephant Lifting Products jumbo beam clamp and contains important rating data.

If you have any questions concerning the operation of Elephant Lifting Products jumbo beam clamps which are not addressed in this operation manual, please contact us at the following address:

Elephant Lifting Products  
38381 N. Robert Wilson Rd.  
Gonzales, Louisiana, 70737  
Phone: (888) 844-6113  
Fax: (225) 644-6695  
e-mail: [sales@elephantlifting.com](mailto:sales@elephantlifting.com)

## 2 Product Description

The Elephant Lifting Products jumbo beam clamp is used for applications where a lifting point is required. The clamp is attached directly to the flange of a structural jumbo beam for lifting purposes. The jumbo beam clamp is attached with its plates clamped directly onto a jumbo beam. The jumbo beam clamp can also be suspended with a hook over its hang bar. The jumbo beam clamp width is adjusted to fit a beam profile within the range given to you in Section 10. When in doubt, always contact the factory or a certified rigger.

## 2.1 Main Components

Elephant Lifting Products jumbo beam clamps consist of the following main components:

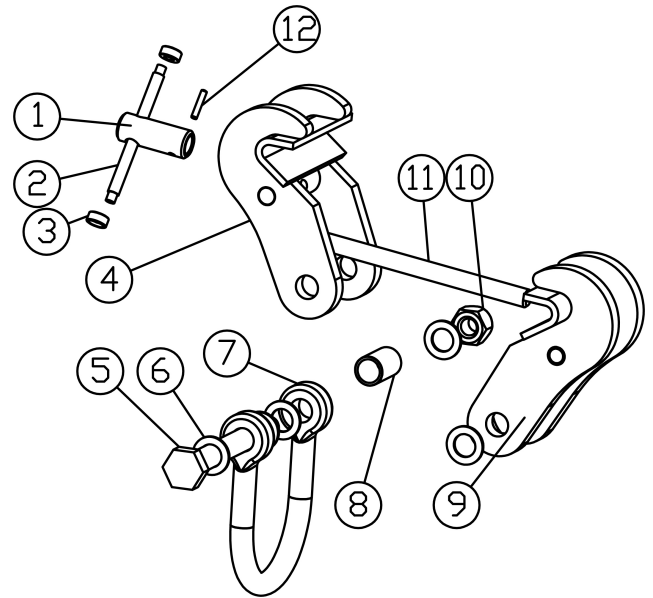

Parts Code	Description of parts
1	Handle body
2	Handle bar
3	Die
4	Left clamp assy
5	Bolt
6	Washer
7	Lifting ring
8	Spacer Bushing
9	Right clamp assy
10	Metal self locked nut
11	Jacking rod
12	Spring pin

### **3 Intended Use**

The Elephant Lifting Products jumbo beam clamp was designed for quick and easy installation and to enable loads of up to the capacity specified, to be clamped safely. The rated load specified on the component is the maximum load that must not be exceeded.

Elephant Lifting Products jumbo beam clamps are intended to be used exclusively for lifting and lowering loads.

Any other use or use outside these stipulations is deemed to be impermissible. Elephant Lifting Products cannot be held liable for any damage resulting from incorrect usage. The entire risk is borne by the operator.

The following situations, among others, are regarded as improper use:

- Exceeding the permitted load-carrying capacity
- Oblique pulling of loads (Refer to Section 8.2)
- Sliding loads
- Detaching, dragging or pulling of loads
- Catching of falling loads
- Carrying people

See also Rules for the safe operation of jumbo beam clamps, Section 8.1.

Intended use also includes observance of the operation manual and compliance with the inspection and maintenance conditions.

### **4 Operating Conditions**

Elephant Lifting Products Jumbo Beam Clamps are extremely robust and require little maintenance. They are suitable for use in areas with high humidity and ambient temperatures of 32° F (0° C) up to approx. 151° F (66° C) if they are not heated above this level due to external influences.

## **CAUTION**

When touching metallic parts of the jumbo beam clamp, which are colder than 32° F (0° C), skin could freeze within a few seconds, and at temperatures above 109° F (43° C), burns may occur. As a protective measure, please wear suitable gloves.

For stationary outdoor operation, jumbo beam clamps must be protected against weathering and the maintenance intervals must be shortened.

### **5 Transport and Storage**

#### **5.1 Safe Transportation**

If you wish to transport your Elephant Lifting Products Jumbo Beam Clamps to another site, please observe the following points:

- Carefully dismantle jumbo beam clamp.
- Set the entire clamp down carefully; do not allow it to drop. For weights see **Technical data**, Section 10.

#### **5.2 Breaks in Operation**

In the case of longer operational breaks, coat the threaded rod with grease.

#### **5.3 Storage**

- Always store the clamp in a no load condition.
- Wipe off all dirt and water.
- Grease the jacking rod.  
Store the jumbo beam clamp in a clean dry environment.
- Before returning the jumbo beam clamp to service, follow instructions for jumbo beam clamps not in regular service in Section 7.6.

### **6 Initial Operation**

The four most important aspects of jumbo beam clamp operation are:

1. Follow all safety instructions when operating the beam clamp.
2. Allow only people trained in safety and operation of this product to work with the clamp.
3. Subject each jumbo beam clamp to a regular inspection and maintenance as outlined in this manual under the Section 6 and 9.
4. Be aware of the jumbo beam clamps rated load and weight of load at all times.

Operators must be physically competent. Operators must have no health condition which might affect their ability to



act, and they must have good hearing, vision and depth perception. The jumbo beam clamp operator must be carefully instructed in his duties and must understand the operation of the hoist, including a study of manufacturer's literature. The operator must thoroughly understand proper methods of hitching loads and should have a good attitude regarding safety. It is the operator's responsibility to refuse to use the clamp under unsafe conditions.

### 6.1 Installation of the Jumbo Beam Clamp

The jumbo beam clamp is to be opened wide enough to fit over the width of the beam. This can be done by rotating the clamp handle in an anti-clockwise direction. Once the clamp fits over the beam rotate the clamp handle clockwise to fasten the clamp onto the beam. The jumbo beam clamp must not be put under load during installation. Refer to the figure below for correct and incorrect fastening positions.

 Correct:

The arms of the jumbo beam clamp are resting on the vertical or horizontal part of the beam flange.

 Incorrect:

There is a gap between one or both of the arms of the jumbo beam clamp and the beam flange.

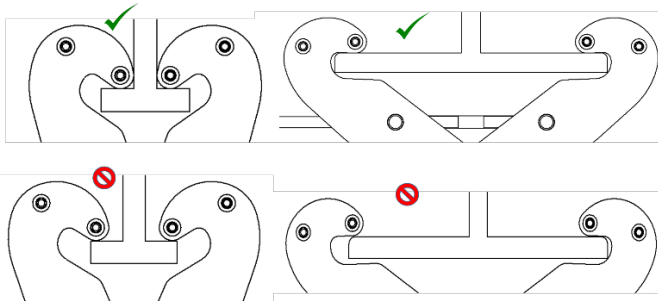

**DANGER**

Elephant Lifting Products jumbo beam clamps must only be installed by qualified personnel. Faulty installation can lead to serious accidents.

**CAUTION**

The girders for the Elephant Lifting Products jumbo beam clamps must be able to safely withstand the expected forces.

The calculation of the static load and the selection of the beam profile are the responsibility of the operator. The carrying capacity of the suspended hoist must not be bigger than the capacity of the jumbo beam clamp.

Elephant Lifting Products jumbo beam clamps are designed for beam profiles or similar profiles.

Please supply adequate working tools.

Please look for a safe place for the mounting personnel.

**DANGER**

Incorrect suspension/loading of the hang bar, i.e. over the flat cross-section, causes danger of fracture and is therefore not permissible.

**DANGER**

Do not drop lifting equipment; equipment should always be placed properly onto the floor.

#### ATTENTION!

After mounting please check that the arms of the jumbo beam clamp are resting on the vertical or horizontal part of the beam flange.

### 6.2 Lubrication

To ensure continued satisfactory operation of the jumbo beam clamp, all points requiring lubrication must be serviced with the correct lubricant at the proper time interval. Correct lubrication is one of the most important factors in maintaining efficient operation.

The lubrication intervals recommended in this manual are based on intermittent use of the jumbo beam clamp eight hours each day, five days per week. If the jumbo beam clamp is operated almost continuously or more than the eight hours each day, more frequent lubrication will be required. Lubrication of the jacking threaded rod with standard grease is necessary for standard jumbo beam clamps.

**CAUTION**

To prevent thread galling from occurring, grease must be applied more frequently to the stainless steel clamp jacking threaded rod.

## 7 Inspection

Elephant Lifting Products recommends two types of inspection:

1. The frequent inspection performed by the operator as pre-work inspection.
2. The periodic inspections performed by personnel trained in the operation of this jumbo beam clamp.

Careful inspection on a regular basis will reveal potentially dangerous conditions while still in the early stages, allowing corrective actions to be taken before the condition becomes dangerous.



Any deficiency revealed through inspection must be reported to an appointed person. A determination must be made as to whether a deficiency constitutes a safety hazard before resuming operation of the clamp.

The results of the inspection must be recorded in an inspection log.

### 7.1 Initial Inspection

Beam clamps have to comply with the regulations for the prevention of accidents valid for jumbo beam clamps. Before beginning to use the jumbo beam clamp for the first time it has to be inspected by a designated person. The inspection procedure is that mentioned in Section 7.4. If any deficiencies are identified, the clamp shall be examined by a qualified person.

### 7.2 Every Lift Inspection

An inspection must be performed on the following jumbo beam clamp items before and/or during every lift for any indication of damage. This includes observations for any damage during operation.

1. Ensure that the plate surface with which the clamp is to come into contact is free of scale, grease, oil paint, water, ice, moisture, dirt and coatings that might impede the contact of the gripping surface with the load.
2. Check that the working load sticker on the girder clamp corresponds with the load to be lifted.
3. Ensure that the jacking threaded rod is well greased.
4. Check for any cracks, deformation or excessive wear on the components.

### 7.3 Frequent Inspection

On jumbo beam clamps in continuous service, frequent inspection should be made at the beginning of each shift. In addition, visual inspections should be conducted during regular service for any damage or evidence of malfunction. The following must be inspected on the jumbo beam clamp during each inspection:

1. Side plates, hang bar, threaded rod, support pins and clamp handle require inspection for deformation, cracks or excessive wear.
2. Check the threaded rod for its function by opening and closing the clamp (when the operation of the clamp is stiff or heavy, it should be removed from operation).
3. Loose or missing warning stickers or nameplates.

### 7.4 Periodic Inspection

Frequency of periodic inspection depends on the severity of usage:

NORMAL	HEAVY	SEVERE
Yearly	Biannually	Quarterly

A complete inspection of the clamp shall be performed at intervals as defined above. Any deficiencies, such as

listed below, shall be examined and determination made as to whether they constitute a hazard.

1. Side plates, hang bar, jacking threaded rod, trunnions, support pins and clamp handle require inspection for deformation, cracks or excessive wear.
2. Check the jacking threaded rod for its function by opening and closing the clamp (when the operation of the clamp is stiff or heavy, it should be removed from operation).
3. Loose or missing warning stickers or nameplates.

#### 7.4.1 Records and Reports

An inspection record should be maintained for each jumbo beam clamp, listing all points requiring periodic inspection. A written report should be made monthly on the condition of the critical parts of each jumbo beam clamp. These reports should be dated, signed by each person who performed the inspection, and kept on file where they are readily available to authorized personnel.

### 7.5 Daily Inspection for Machines Operated in Corrosive Environments

If the clamp operating environment is at all corrosive, a more in depth daily inspection should be undertaken; jacking threaded rod should be well greased.

### 7.6 Girder Clamp Not in Regular Use

1. A jumbo beam clamp which has been idle for a period of one month or more, but less than one year, should be given an inspection conforming with the requirements for "Frequent Inspection" prior to being placed into service.
2. A jumbo beam clamp which has been idle for a period of more than one year should be given an inspection conforming with the requirements of "Periodic Inspection" prior to being placed into service.
3. Standby jumbo beam clamp should be inspected at least biannually in accordance with the requirement of "Frequent Inspection". In abnormal operating conditions jumbo beam clamps should be inspected at shorter intervals.

## 8 Operation

### 8.1 Rules for the Safe Operation of Jumbo Beam Clamps

In addition to the rules listed under section "Initial Operation" the following rules have to be observed:

If several jumbo beam clamps are working together, the customer has to set up the conditions for safe operation.

If the local conditions or the work to be performed make it necessary, the customer has to define operating instructions.

Maintenance and inspection work may only be performed once the people in charge are convinced that the jumbo beam clamp is not under load and has been unmounted from the beam.

If components other than Elephant Lifting Products components are used, danger may occur. Such an application can only be allowed after having received Elephant Lifting Products agreement.

## 8.2 Operating Limits of the Jumbo Beam Clamp

**CAUTION**

Before using the jumbo beam clamp. The beam should be tested by an expert or the manufacturer of the beam to check that it is suitable for use with the jumbo beam clamp.

**DANGER**

Do not load the jumbo beam clamp at an angle in the same plane as the direction of the length of the beam. Only loading perpendicular to the length of the beam is permitted. Refer to the figures below for more information on the correct and incorrect method of loading the jumbo beam clamp.

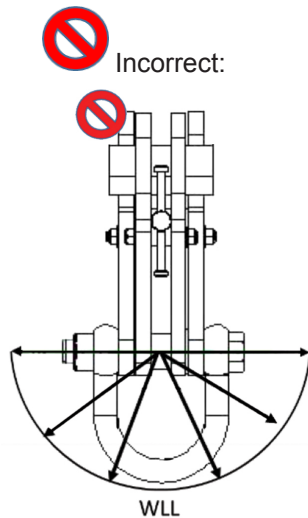

✓ Correct:

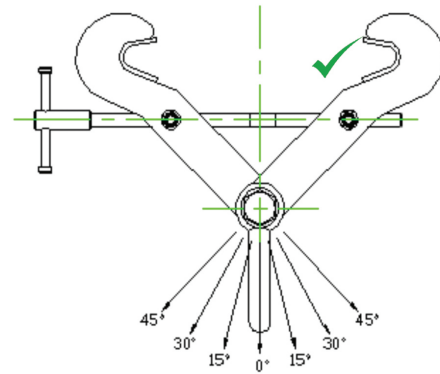

## 9 Maintenance

### 9.1 Maintenance and Inspection Intervals

Elephant Lifting Products jumbo beam clamps are extremely robust and require little maintenance. Compliance with maintenance and inspection intervals is of great importance, in order that the jumbo beam clamps operate safely and reliably over a period of many years. If the jumbo beam clamp is being operated in a harsh environment that leads to accelerated wear, then the intervals should be reduced.

**CAUTION**

Maintenance work on Elephant Lifting Products jumbo beam clamps must only be performed by trained and qualified personnel.

In the case of maintenance work exceeding normal service and maintenance, please contact Elephant Lifting Products .

### 9.2 Cleaning and Care

If your Elephant Lifting Products jumbo beam clamp has to work in dirty surroundings, remove coarse dirt from the clamp and grease jacking threaded rod.

### SIDE LOAD ACROSS BEAM ONLY - CLAMP MUST BE FLUSH ON BEAM WITH SHACKLE AT A ZERO DEGREE DOWNWARD FACING ANGLE

Chart only applies to overhead beam attachment. If clamps are being used to lift beams, this information is not applicable. Table applies to the listed models only. Stress calculations should be performed by the end user's engineering dep.	Reduction in working load limit when side loads are applied				
	Angle from vertical (degree)	0	0 to 15	15 to 30	30 to 45
	Reduction Factor	NIL	17.00%	34.00%	50.00%
	Model	WLL	WLL	WLL	WLL
	JBC-3A	3 ton	2.5 ton	2 ton	1.5 ton
	JBC-5A	5 ton	4.1 ton	3.3 ton	2.5 ton
	JBC-6	6 ton	5 ton	4 ton	3 ton
	JBC-10	10 ton	8.3 ton	6.6 ton	5 ton
	JBC-16B JBC-16A	16 ton	13.2 ton	10.5 ton	8 ton

\* Warning: Clamps must be installed properly and fully tightened

\* Always contact the manufacturer when in doubt

## 10 Technical Data

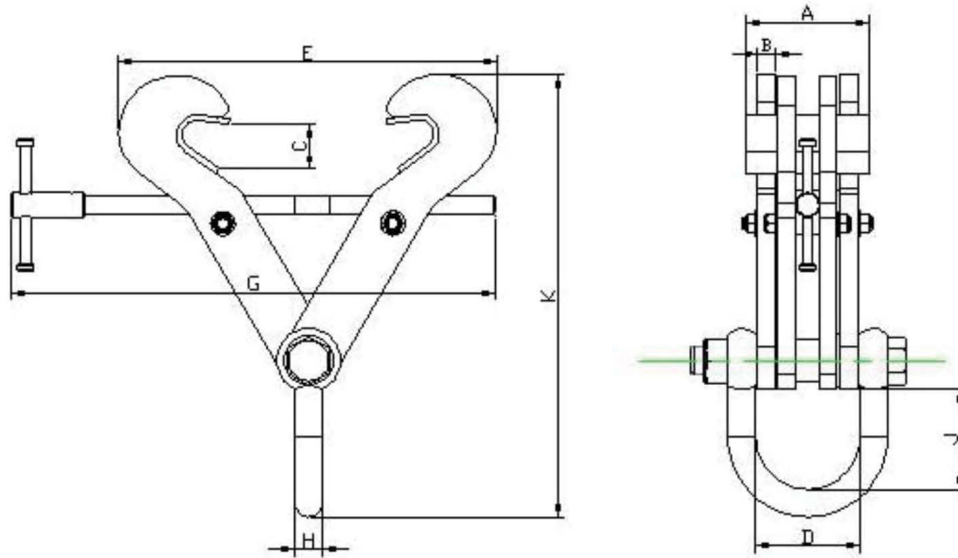

The Jumbo Beam Clamp is a great option for rigging applications. This clamp line features a wide jaw opening for wide flange beams used throughout industry. The JBC's clamp screw assembly is also zinc plated. This clamp series features metric capacities that range from 3, 5, 6, 10 and 16 tons.

### SPECIFICATIONS & DIMENSIONS - JUMBO BEAM CLAMP

Type	S.W.L. (lbs.)	S.W.L. US Ton	Beam Width (inch)	Dimensions (inch)									Jaw Type	Weight (lbs)
				A	B	C	D	E max	G	H	J	K min		
JBC-3A	6600	3.3	3.00-7.48	5.12	0.55	1.06	4.21	10.71	10.87	0.79	3.35	10.00	Fixed	18
JBC-5A	11000	5.5	6.00-12.00	5.50	0.55	1.81	4.80	17.72	16.10	0.98	3.90	12.56	Fixed	33
JBC-5B	11000	5.5	3.00-7.48	5.50	0.55	1.81	4.80	13.39	13.35	0.98	3.90	12.99	Fixed	22
JBC-6	13200	6.6	8.00-18.00	6.60	0.55	2.17	4.57	23.62	22.01	0.98	3.90	16.46	Fixed	42
JBC-10	22000	11	8.00-18.00	5.51	0.79	2.17	4.69	23.62	22.01	1.26	3.90	16.46	Fixed	62
JBC-16A	35000	17.6	16.00-24.00	6.89	0.79	3.00	5.12	24.02	31.89	1.77	7.87	25.75	Fixed	135
JBC-16B	35000	17.6	8.00-18.00	6.89	0.79	3.00	5.12	17.99	25.98	1.77	7.87	22.60	Fixed	119

**Elephant Lifting Products, LLC**  
**38381 N. Robert Wilson Rd. | Gonzales, Louisiana 70737 • USA**  
**Toll Free: 1.888.844.6113 • Phone: 1.225.644.6113 • Fax: 1.225.644.6695**  
**[www.elephantlifting.com](http://www.elephantlifting.com) • [sales@elephantlifting.com](mailto:sales@elephantlifting.com)**