



## UGC - UNIVERSAL CLAMP MANUAL



**ELEPHANT**  
LIFTING PRODUCTS™

## **Contents**

Preface .....	2
1 Safety Information .....	3
2 Identification .....	5
3 Product Description .....	5
3.1 Main Components .....	5
4 Intended Use .....	5
5 Operating Conditions .....	6
6 Transport and Storage .....	6
6.1 Safe Transportation .....	6
6.2 Breaks in Operation .....	6
6.3 Storage .....	6
7 Initial Operation .....	6
7.1 Installation of the Girder Clamp .....	6
7.2 Lubrication .....	7
8 Inspection .....	7
8.1 Initial Inspection .....	7
8.2 Every Lift Inspection .....	7
8.3 Frequent Inspection .....	7
8.4 Periodic Inspection .....	8
8.5 Daily Inspection for Machines Operated in Corrosive Environments .....	8
8.6 Girder Clamp Not in Regular Use .....	8
9 Operation .....	8
9.1 Rules for the Safe Operation of Universal Girder Clamps .....	8
9.2 Operating Limits of the Universal Girder Clamp .....	9
10 Maintenance .....	9
10.1 Maintenance and Inspection Intervals .....	9
10.2 Cleaning and Care .....	9
10.3 Spare Parts .....	9
11 Technical Data .....	10

This operation manual edition 04/2017 covers Elephant Lifting UGC Universal Girder Clamps:

It must be read carefully and in its entirety before operating any girder clamp.

Serial No.

Please enter the Serial No. of your Elephant Lifting UGC universal girder clamp here.

### **THIS MANUAL MUST BE READ BEFORE USING THESE PRODUCTS.**

This manual contains important safety, installation, operation, and maintenance and repair information. Make this manual available to all persons responsible for the operation, installation, maintenance and repair of these products.

**Do not use this clamp for lifting, supporting, or transporting people or lifting or supporting loads over people.**

#### **For Clamps used outside of South Africa:**

It is the responsibility of the owner/user to source, install, inspect, test, maintain, and operate a clamp in accordance with any applicable standards.

If the girder clamp owner/user requires additional information, or if any information in the manual is not clear, contact Elephant Lifting Products or the distributor of the universal girder clamp. Do not install, inspect, test, maintain, or operate this universal girder clamp unless this information is fully understood.

A regular schedule of inspection of the universal girder clamp in accordance with any applicable standards.

## **Preface**

Elephant Lifting Products warrants to the user its universal girder clamps, and other products to be free from defects in material and workmanship for a period of one year from the date of purchase.

Elephant Lifting Products will repair, without cost to the user, any product found to be defective, including parts and labour charges, or at Elephant Lifting Products' option, will replace such products or refund the purchase price less a reasonable allowance for handling in exchange for the product. Repair and replacements are warranted for the remainder of the original warranty period.

If any product proves defective within its original one year warranty period, it shall be returned to Elephant Lifting Products with proof of purchase and the original test certificate.

This warranty does not apply to products which Elephant Lifting Products has determined to have been misused or abused, improperly maintained by the user, or where the malfunction or defect can be attributed to the use of non-genuine Elephant Lifting Products parts.

Elephant Lifting Products makes no other warranty and its maximum liability is limited to the purchase price of the product and in no event will Elephant Lifting Products liable for any consequential, indirect, incidental or special damages of any nature arising from the sale or use of the product whether based on contract or otherwise.

It is Elephant Lifting Products policy to promote safety of all persons and equipment in the workplace. All equipment manufactured is thoroughly checked, packed and inspected before dispatch. Any loss or damage which occurs during shipment while en-route must be reported to Elephant Lifting Products immediately. Should any item be delivered to you in apparent good condition, but upon opening the container, loss or damage has taken place while in transit; notify Elephant Lifting Products immediately. Should any items be delivered back to Elephant Lifting Products all transport costs will be for the account of the user.

These instructions are prepared by Elephant Lifting

## 1 Safety Information

This manual will refer to existing legal requirements and engineering practices as known when this document was written. Should any such legislation or practices change or be "enlarged" upon then due consideration must be taken. Various standards have been used to assist in compiling this document and will be listed where applicable.

The use of powerful lifting equipment is subject to certain hazards that cannot be overcome by mechanical means but only by the exercise of intelligence, care and common sense. It is therefore essential that personnel involved in the use and operation of equipment must be competent, careful, physically and mentally qualified, and trained in the safe operation of equipment and the handling of the loads. Serious hazards include but are not limited to are overloading, dropping or slipping of the load caused by improper hitching or slinging, obstructing the free passage of the load and using equipment for a purpose for which it was not intended or designed. The above can lead to fatal consequences.

Operators of Elephant Lifting Products Universal Girder Clamps are also under obligation to ensure safe and hazard-free operation. This can be achieved through the following measures:

- Keep the operation manuals available at the universal girder clamp operating site,
- Perform regular training,
- Perform regular inspections (at least once annually),
- Implement an inspection log and make regular entries,
- And regularly check personnel for safety and hazard awareness during work.

Elephant Lifting Products fully realizes the importance of proper design factors, minimum and maximum sizes and other limiting dimensions of the structural components of the clamp, all of which are designed with safety in mind.

The various conditions of the equipment or material can vary depending on the environment they are used in which may cause corrosion or wear and any other variables that may arise in each individual application. It is in the light of this that the girder clamp be maintained and repaired under the supervision of a competent person:

- 1) Who is qualified by virtue of his knowledge, training, skills and experience to organize the work and its performance;
- 2) Who is familiar with the legal requirements which apply to the work to be performed;
- 3) Who has been trained to recognize any potential or

The instructions given in this manual must be interpreted accordingly and sound judgment used in determining their application.

This operation manual is intended to help the operator to become familiar with Elephant Lifting Products universal girder clamps and how to use them properly.

This operation manual contains important information for the safe, proper and efficient operation of Elephant Lifting Products universal girder clamps. Observance of the manual helps to avoid hazardous situations, to reduce repair costs and downtimes and to ensure the specified service life of the Elephant Lifting Products Girder Clamps.

**Always keep the manual readily available at the location where the Elephant Lifting Products universal girder clamp is being used.**

**All persons charged with operating, maintaining or repairing Elephant Lifting Products universal girder clamps must read and follow the instructions in this manual.**

### **Danger, Warning, Caution and Notice**

Throughout this manual there are steps and procedures which, if not followed, may result in an injury. The following signal words are used to identify the level of potential hazard.

**DANGER**

Danger is used to indicate the presence of hazard which **will** cause **severe** injury, death or substantial property damage if the warning is ignored.

**WARNING**

Warning is used to indicate the presence of a hazard which **can** cause **severe** injury, death, or substantial property damage if the warning is ignored.

**CAUTION**

Caution is used to indicate the presence of a hazard which **will** or **can** cause minor injury or property damage if the warning is ignored.

**NOTICE**

Notice is used to notify people of installation, operation, or maintenance information which are important but not hazard-related.

## Safety Summary

### WARNING

- Do not use this universal girder clamp or any equipment attached to it for lifting, supporting, or transporting people or lifting or supporting loads over people.
- Elephant Lifting UGC series of girder clamps are designed to provide a MINIMUM of 3 to 1 safety factor. It is the responsibility of the customer to ensure that the structure to which the girder clamp is attached and any load attaching devices are capable of handling the static and dynamic loads imposed on the structure by the girder clamp and its attachments when lifting the rated load. If in doubt, consult a registered professional structural engineer.

### NOTICE

- Lifting equipment is subject to different regulations in each country. These regulations may not be specified in this manual.
- Whenever a conflict arises between the contents of this manual and any other applicable legislation, standard or procedure, the more stringent of the two must be applied.

The Occupational Health and Safety Act and Mine Health and Safety Act and other recognized safety sources make a common point: Employees who work near cranes or assist in hooking on or arranging a load should be instructed to keep out from under the load.

From a safety standpoint, one factor is paramount: conduct all lifting operations in such a manner that if there were an equipment failure, no personnel would be injured. This means keep out from under a raised load and keep out of the intended path of any load.

**Elephant Lifting UGC** universal girder clamps are manufactured in accordance with the latest ISO9001 standards.

The Occupational Safety and Health Act of 1993, section 10 states:

- 1) Any person who designs, manufactures, imports, sells or supplies any article for use at work shall Ensure, as far as is reasonably practicable, that the article is safe and without risks to health when properly used and that it complies with all prescribed requirements.
- 2) Any person who erects or installs any article for use at work on or in any premises shall ensure, as far as

is reasonably practicable, that nothing about the manner in which it is erected or installed makes it unsafe or creates a risk to health when properly used.

- 3) Any person who manufactures, imports, sells or supplies any substance for use at work shall –
  - (a) ensure, as far as is reasonably practicable, that the substance is safe and without risks to health when properly used; and
  - (b) take such steps as may be necessary to ensure that information is available with regard to the use of the substance at work, the risks to health and safety associated with such substance, the conditions necessary to ensure that the substance will be safe and without risks to health when properly used and the procedures to be followed in the case of an accident involving such substance.
- 4) Where a person designs, manufactures, imports, sells, or supplies an article or substance for or to another person, and that other person, and that other person undertakes in writing to take specified steps sufficient to ensure, as far as is reasonable practicable, that the article or substance will comply with all prescribed requirements and will be safe and without risks to health when properly used, the undertaking shall have the effect of relieving the first mentioned person from the duty imposed upon him by this section to such an extent as may be reasonable having regard to the terms of the undertaking.

It is the owner's and user's responsibility to determine the suitability of a product for any particular use. It is recommended that all applicable industry, trade association and legislation be checked. Read all operation instructions and warnings before operation.

This manual has been produced by **Elephant Lifting UGC** to provide agents, fitters, and company personnel with the information required to install, operate, maintain and repair the products described herein.

It is extremely important that fitters and operators be familiar with the servicing procedures of these products, or similar products, and is physically capable of conducting the procedures. These personnel shall have a general working knowledge that includes:

- 1) Proper and safe use and application of fitter's common hand tools as well as special or recommended tools.
- 2) Safety procedures, precautions and work habits established by accepted industry standards.

**Elephant Lifting UGC cannot** know of, nor provide all the procedures by which product operations or repairs may be conducted

and the hazards and/or results of each method. If operation or maintenance procedures not specifically recommended by the manufacturer are conducted, it must be ensured that product safety is not endangered by the actions taken. If unsure of an operation or maintenance procedure or step, personnel should place the product in a safe condition and contact supervisors and/or the factory for technical assistance.

## 2 Identification

The nameplate mounted on the side plate identifies the type of Elephant Lifting Products universal girder clamp and contains important rating data.

If you have any questions concerning the operation of Elephant Lifting Products universal girder clamps which are not addressed in this operation manual, please contact us at the following address:

Elephant Lifting Products  
38381 N. Robert Wilson Rd  
Gonzales, Louisiana, 70737  
Phone: (888) 844-6113  
Fax: (225) 644-6695  
e-mail: sales@elephantlifting.com

## 3 Product Description

The Elephant Lifting Products universal girder clamp is used for applications where a lifting point is required. The clamp is attached directly to the flange of a structural beam for lifting purposes.

The universal girder clamp is attached with its plates clamped directly onto a beam. The universal girder clamp can also be suspended with a hook over its suspension eye.

Elephant Lifting Products universal girder clamps are designed in accordance with in-house standards. They are suitable for girders according to DIN 1025 or similar types of girder.

The universal girder clamp is adjusted by turning the jacking screw, to fit a girder profile within the range given to you in Section 11.

### 3.1 Main Components

Elephant Lifting Products universal girder clamps consist of the following main components:

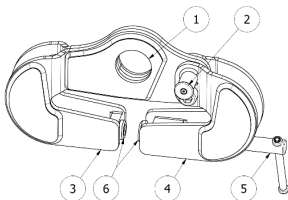

1. Suspension Eye
2. Lock Pin
3. Fixed Side Arm
4. Pivoting Side Arm
5. Jacking Screw
6. Clamping Heads

## 4 Intended Use

The Elephant Lifting Products universal girder clamp was designed for quick and easy installation and to enable loads of up to the capacity specified, to be clamped safely. The rated load specified on the component is the maximum load that must not be exceeded.

Elephant Lifting Products girder clamps in combination with Elephant Lifting Products air hoists are intended to be used exclusively for lifting and lowering loads.

Any other use or use outside these stipulations is deemed to be impermissible. For applications requiring this type of use please consider the Elephant Lifting Products range of winches and the Elephant Lifting Products range of hoists. Elephant Lifting cannot be held liable for any damage resulting from incorrect usage. The entire risk is borne by the operator.

The following situations, among others, are regarded as improper use:

- Exceeding the permitted load-carrying capacity
- Oblique pulling of loads (Refer to Section 9.2)
- Sliding loads
- Detaching, dragging or pulling of loads
- Catching of falling loads
- Carrying people

See also Rules for the safe operation of universal girder clamps, Section 9.1.

Intended use also includes observance of the operation manual and compliance with the inspection and maintenance conditions.

## 5 Operating Conditions

Elephant Lifting Products Universal Girder Clamps are extremely robust and require little maintenance. They are spark resistant and suitable for use in ambient temperatures of  $-4^{\circ}\text{C}$  up to approx.  $+70^{\circ}\text{C}$  if they are not heated above this level due to external influences.

### CAUTION

When touching metallic parts of the girder clamp, which are colder than  $0^{\circ}\text{C}$ , skin could freeze within a few seconds, and at temperatures above  $43^{\circ}\text{C}$ , burns may occur. As a protective measure, please wear suitable PPE.

For stationary outdoor operation, universal girder clamps must be protected against weathering and the maintenance intervals must be shortened.

## 6 Transport and Storage

### 6.1 Safe Transportation

If you wish to transport your Elephant Lifting Products Universal Girder Clamps to another site, please observe the following points:

- Carefully dismount universal girder clamp.
- Set the entire clamp down carefully; do not allow it to drop. For weights see **Technical data**, Section 11.

## 6.2 Breaks in Operation

In the case of longer operational breaks, coat the jacking rod with grease.

## 6.3 Storage

- Always store the clamp in a no load condition.
- Wipe off all dirt and water.
- Grease the jacking rod.
- Store the universal girder clamp in a clean dry environment.
- Before returning the universal girder clamp to service, follow instructions for universal girder clamps not in regular service in Section 8.6.

## 7 Initial Operation

The four most important aspects of girder clamp operation are:

1. Follow all safety instructions when operating the girder clamp.
2. Allow only people trained in safety and operation of this product to work with the clamp.
3. Subject each girder clamp to a regular inspection and maintenance as outlined in this manual under the section 8 Inspection.
4. Be aware of the girder clamps rated load and weight of load at all times.

Operators must be physically competent. Operators must have no health condition which might affect their ability to act, and they must have good hearing, vision and depth perception. The girder clamp operator must be carefully instructed in his duties and must understand the operation of the hoist, including a study of manufacturer's literature. The operator must thoroughly understand proper methods of hitching loads and should have a good attitude regarding safety. It is the operator's responsibility to refuse to use the clamp under unsafe conditions.

### 7.1 Installation of the Girder Clamp

The girder clamp is to be opened wide enough to fit over the width of the beam. This can be done by screwing the jacking screw to the fully retracted position by turning the handle in the anti-clockwise direction.

#### NOTICE

Do not over screw the jacking screw out until the head contacts the side plates. The head is not designed to take load in this direction.

Pulling out the lock pin and rotating the pivoting arm to the open position. Next, place the fixed side arm over the beam and rotate the swivel side arm closed until the locking pin engages (this will be indicated by the audible and tactile cue of the pin "clicking into position"). Next tighten the jacking screw until the clamping heads are tightly engaged with the beam.



Correct:

1. For vertical and transverse loading: The arms of the beam clamp are resting on the horizontal part of the beam flange, the clamp heads are both engaged with the beam. The locking pin is all the way in.
2. For loading along the beam's length: The one side of both arms of the beam clamp is resting on the horizontal part of the beam flange, the clamp is rotated at an angle towards the lifting direction and the body of the clamp contacts the outer part of the beam flange; the clamp heads are both engaged with the beam. The locking pin is all the way in.



Incorrect:

Only one of the arms of the beam clamp is resting on the horizontal part of the beam flange, only one of the clamp heads is engaged with the beam web. The locking pin is not completely in.

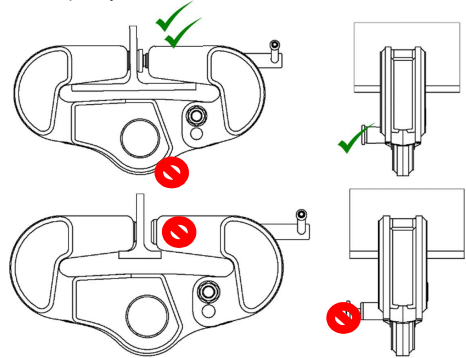

Figure 1: Clamp installation for vertical and transverse loading

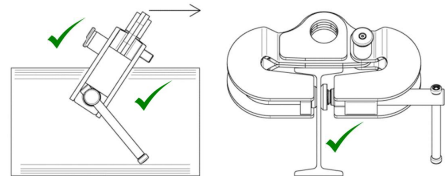

Figure 2: Clamp installation for loading down the beam

## **DANGER**

Elephant Lifting Products universal girder clamps must only be installed by qualified personnel. Faulty installation can lead to serious accidents.

## **CAUTION**

The girders for the Elephant Lifting Products universal girder clamps must be able to safely withstand the expected forces, and must be sufficiently hard that the clamping head does not cause structural damage when tightened against the beam.

The calculation of the static load and the selection of the girder profile are the responsibility of the operator. The carrying capacity of the suspended hoist must not be bigger than the capacity of the girder clamp.

Elephant Lifting Products universal girder clamps are designed for girder profiles or similar profiles.

Please supply adequate working tools.

Please look for a safe place for the mounting personnel.

## **DANGER**

Incorrect suspension/loading of the Elephant Lifting Products Universal Girder Clamp, i.e. over any section other than the mounting hole, causes danger of excessive deformation and is therefore not permissible.

## **DANGER**

Do not drop lifting equipment; equipment should always be placed properly onto the floor.

### **ATTENTION!**

After mounting please check that the arms of the beam clamp are resting on the horizontal part of the beam flange.

### **7.2 Lubrication**

To ensure continued satisfactory operation of the universal girder clamp, all points requiring lubrication must be serviced with the correct lubricant at the proper time interval. Correct lubrication is one of the most important factors in maintaining efficient operation.

The lubrication intervals recommended in this manual are based on intermittent use of the universal girder clamp eight hours each day, five days per week. If the universal girder clamp is operated almost continuously or more than the eight hours each day, more frequent lubrication

will be required. Lubrication of the jacking threaded rod with standard grease is necessary.

## **8 Inspection**

Elephant Lifting Products recommends two types of inspection:

1. The frequent inspection performed by the operator as pre-work inspection.
2. The periodic inspections performed by personnel trained in the operation of this universal girder clamp.

Careful inspection on a regular basis will reveal potentially dangerous conditions while still in the early stages, allowing corrective actions to be taken before the condition becomes dangerous.

Any deficiency revealed through inspection must be reported to an appointed person. A determination must be made as to whether a deficiency constitutes a safety hazard before resuming operation of the clamp.

The results of the inspection must be recorded in an inspection log.

### **8.1 Initial Inspection**

Universal girder clamps have to comply with the regulations for the prevention of accidents valid for girder clamps. Before beginning to use the girder clamp for the first time it has to be inspected by a designated person. The inspection procedure is that mentioned in Section 8.4. If any deficiencies are identified, the clamp shall be examined by a qualified person.

### **8.2 Every Lift Inspection**

An inspection must be performed on the following universal girder clamp items before and/or during every lift for any indication of damage. This includes observations for any damage during operation.

1. Ensure that the plate surface with which the clamp is to come into contact is free of scale, grease, oil paint, water, ice, moisture, dirt and coatings that might impede the contact of the gripping surface with the load.
2. Check that the working load sticker on the girder clamp corresponds with the load to be lifted.
3. Ensure that the jacking threaded rod is well greased.
4. Check for any cracks, deformation or excessive wear on the components.

### **8.3 Frequent Inspection**

On universal girder clamps in continuous service, frequent inspection should be made at the beginning of each shift. In addition, visual inspections should be conducted during regular service for any damage or evidence of malfunction. The following must be inspected on the universal girder clamp during each inspection:



1. Fixed - and swivel arm - plates, suspension eye, jacking screw, locking pin, clamping heads, pivot bolt require inspection for deformation, cracks or excessive wear.
2. Check the clamp for its function by opening and closing the clamp (when the operation of the clamp is stiff or heavy, it should be removed from operation).
3. Loose or missing warning stickers or nameplates.

#### 8.4 Periodic Inspection

Frequency of periodic inspection depends on the severity of usage:

NORMAL	HEAVY	SEVERE
Yearly	Biannually	Quarterly

A complete inspection of the clamp shall be performed at intervals as defined above. Any deficiencies, such as listed below, shall be examined and determination made as to whether they constitute a hazard.

1. Fixed - and swivel arm - plates, suspension eye, jacking screw, locking pin, clamping heads, pivot bolt require inspection for deformation, cracks or excessive wear.
2. Check the clamp for its function by opening and closing the clamp (when the operation of the clamp is stiff or heavy – or if the clamp has excessive play, it should be removed from operation).
3. Loose or missing warning stickers or nameplates.

##### 8.4.1 Records and Reports

An inspection record should be maintained for each universal girder clamp, listing all points requiring periodic inspection. A written report should be made monthly on the condition of the critical parts of each universal girder clamp. These reports should be dated, signed by each person who performed the inspection, and kept on file where they are readily available to authorized personnel.

#### 8.5 Daily Inspection for Machines Operated in Corrosive Environments

If the machine operating environment is at all corrosive, a more in depth daily inspection should be undertaken; and the jacking threaded rod should be well greased.

#### 8.6 Girder Clamp Not in Regular Use

1. A universal girder clamp which has been idle for a period of one month or more, but less than one year, should be given an inspection conforming with the requirements for "Frequent Inspection" prior to being placed into service.
2. A girder clamp which has been idle for a period of more than one year should be given an inspection conforming with the requirements of "Periodic Inspection" prior to being placed into service.
3. Standby girder clamp should be inspected at least biannually in accordance with the requirement of "Frequent Inspection". In abnormal operating

conditions girder clamps should be inspected at shorter intervals.

## 9 Operation

### 9.1 Rules for the Safe Operation of Universal Girder Clamps

In addition to the rules listed under section "Initial Operation" the following rules have to be observed:

If several universal girder clamps are working together, the customer has to set up the conditions for safe operation.

If the local conditions or the work to be performed make it necessary, the customer has to define operating instructions.

Maintenance and inspection work may only be performed once the people in charge are convinced that the universal girder clamp is not under load and has been dismantled from the girder.

If components other than Elephant Lifting Products components are used, danger may occur. Such an application can only be allowed after having received Elephant Lifting Products' agreement.



This is NOT a plate clamp. Only webbed and flanged members may be lifted with or used to secure the Universal Girder Clamp.

## 9.2 Operating Limits of the Universal Girder Clamp

### CAUTION

Before using the girder clamp. The beam should be tested by an expert or the manufacturer of the beam to check that it is suitable for use with the beam clamp.

### DANGER

Refer to the figures below for more information on the correct and incorrect method of loading the girder clamp.



Correct:

The beam is loaded to no more than 100% WLL. The loading is in an arc of  $-90$  to  $+90$  along the x-z or y-z planes.

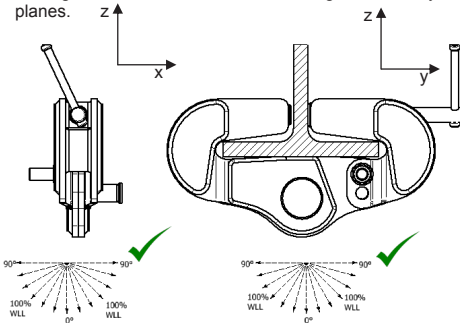

**Special note on the the UGC – 2 (i.e. 2 ton UGC clamp).** To avoid damage to the locking pin the 2t Universal Girder Clamp must only be loaded as below.

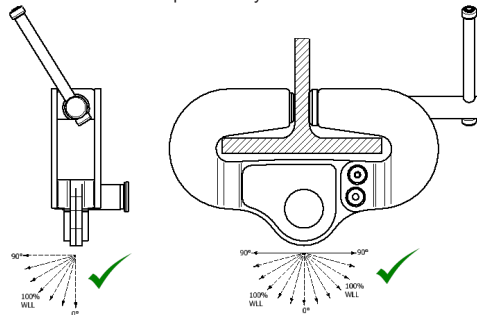

## 10 Maintenance

### 10.1 Maintenance and Inspection Intervals

Elephant Lifting Products universal girder clamps are extremely robust and require little maintenance. Compliance with maintenance and inspection intervals is of great importance, in order that the girder clamps operate safely and reliably over a period of many years. If the girder clamp is being operated in a harsh environment that leads to accelerated wear, then the intervals should be reduced.

### CAUTION

Maintenance work on Elephant Lifting Products universal girder clamps must only be performed by trained and qualified personnel.

In the case of maintenance work exceeding normal service and maintenance, please contact Elephant Lifting Products.

### 10.2 Cleaning and Care

If your Elephant Lifting Products universal girder clamp has to work in dirty surroundings, remove coarse dirt from the clamp and grease jacking screw.

### 10.3 Spare Parts

There are no spare parts available for the Elephant Lifting UGC girder clamps and therefore if repairing is required the girder clamp must be replaced.

### NOTICE

- Please note the requirements of the Occupational Health and Safety Act of South Africa (Act 85 of 1993), Driven Machinery (Regulation 18) Lifting Machines and Lifting Tackle regarding the examination and testing of lifting machines and lifting tackle.
- Or the relevant legal requirements of the country where the machine is to be used.

## 11 Technical Data

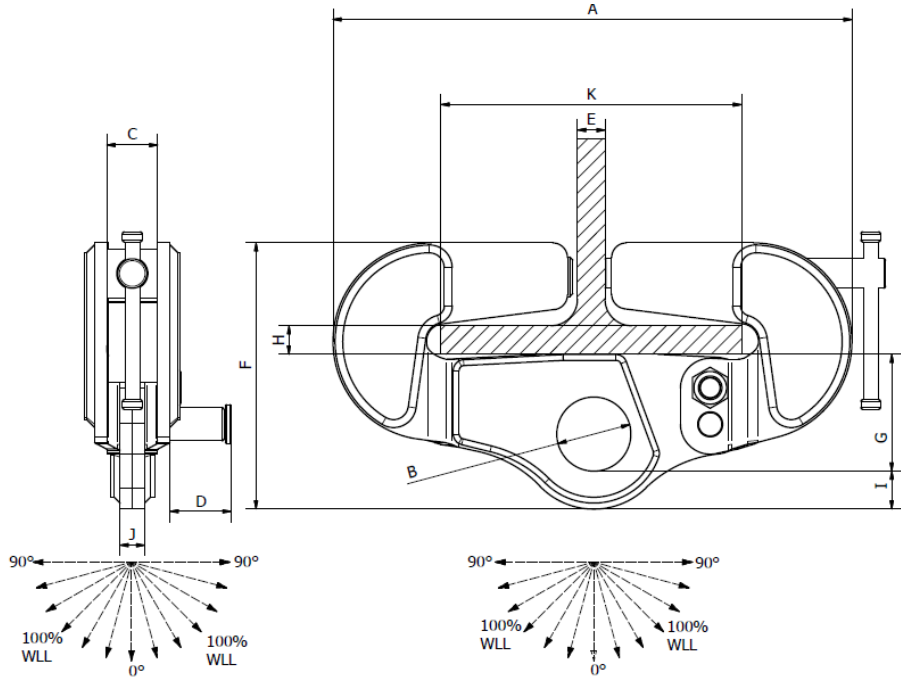

Figure 1 : Technical Drawing

Product Code	Capacity [tonne]	Dimensions [mm]										Net Mass [kg]	
		A	B	C	D	E	F	G	H	I	J		K
ATS-UGC - 2	2	360	52	51.50	50	32	209	91	25.4	23	16	125-204	10
ATS-UGC - 3	3	390	68	51.50	50	32	228	100	25.4	28	20	125-204	14
ATS-UGC - 5	5	527	75	51.50	50	32	270	120	25.4	38	25	125-305	28
ATS-UGC - 10	10	525	76	51.50	102	32	271	120	25.4	38	50	125-305	42

Figure 2 : Table of Sizes

Due to continued innovation and improvement of our products, specifications and dimensions are subject to change without notice. Please consult Elephant Lifting with any questions.



Elephant Lifting Products, LLC  
38381 N. Robert Wilson Rd. | Gonzales, Louisiana 70737 • USA  
Toll Free: 1.888.844.6113 • Phone: 1.225.644.6113 • Fax: 1.225.644.6695  
[www.elephantlifting.com](http://www.elephantlifting.com) • [sales@elephantlifting.com](mailto:sales@elephantlifting.com)