

FRAME MATERIAL: STEEL
 WHEELS: SOLID RUBBER
 BRAKE: YES
 LOAD CAPACITY: 1,000 LBS.
 WEIGHT: 78 LBS.
 WIDTH: 25"
 DEPTH: 19-3/4"
 HEIGHT: 52"
 LOCKING CHIME HOOK "L" AS SUFFIX
 FIBER CHIME HOOK "F" AS SUFFIX
 CABLE CHIME HOOK "C" AS SUFFIX
 PLASTIC CHIME HOOK "P" AS SUFFIX

PROPRIETARY AND CONFIDENTIAL

THE INFORMATION CONTAINED IN THIS DRAWING IS THE SOLE PROPERTY OF VALLEY CRAFT. ANY REPRODUCTION IN PART OR AS A WHOLE WITHOUT THE WRITTEN PERMISSION OF VALLEY CRAFT IS PROHIBITED.

UNLESS OTHERWISE SPECIFIED:

DECIMALS
 2 PLACES ±0.01
 3 PLACES ±0.005
 ANGLE ±1°

GRIND/SAND SHARP EDGES .015 MAX DOES NOT APPLY TO DRILLED HOLE DIA.



TITLE: TRK-DRUM/625SS STD CH

B	-	CREATED	DN	04/19/2019
CHG.	E.C.O.	DESCRIPTION / WAS	BY	DATE

ALL ANGLES ARE 90° UNLESS SPECIFIED

	NAME	DATE
DRAWN	DN	04/19/2019
CHECKED		
ENG APPR.		

SIZE	PART NO.	F82150A1
A	MATL:	Material <not specified>
SCALE: 1:16	WEIGHT: 65.88	SHEET 1 OF 3

Not Modeled F60180A1: BRAKE CABLE ASSEMBLY Qty. 1

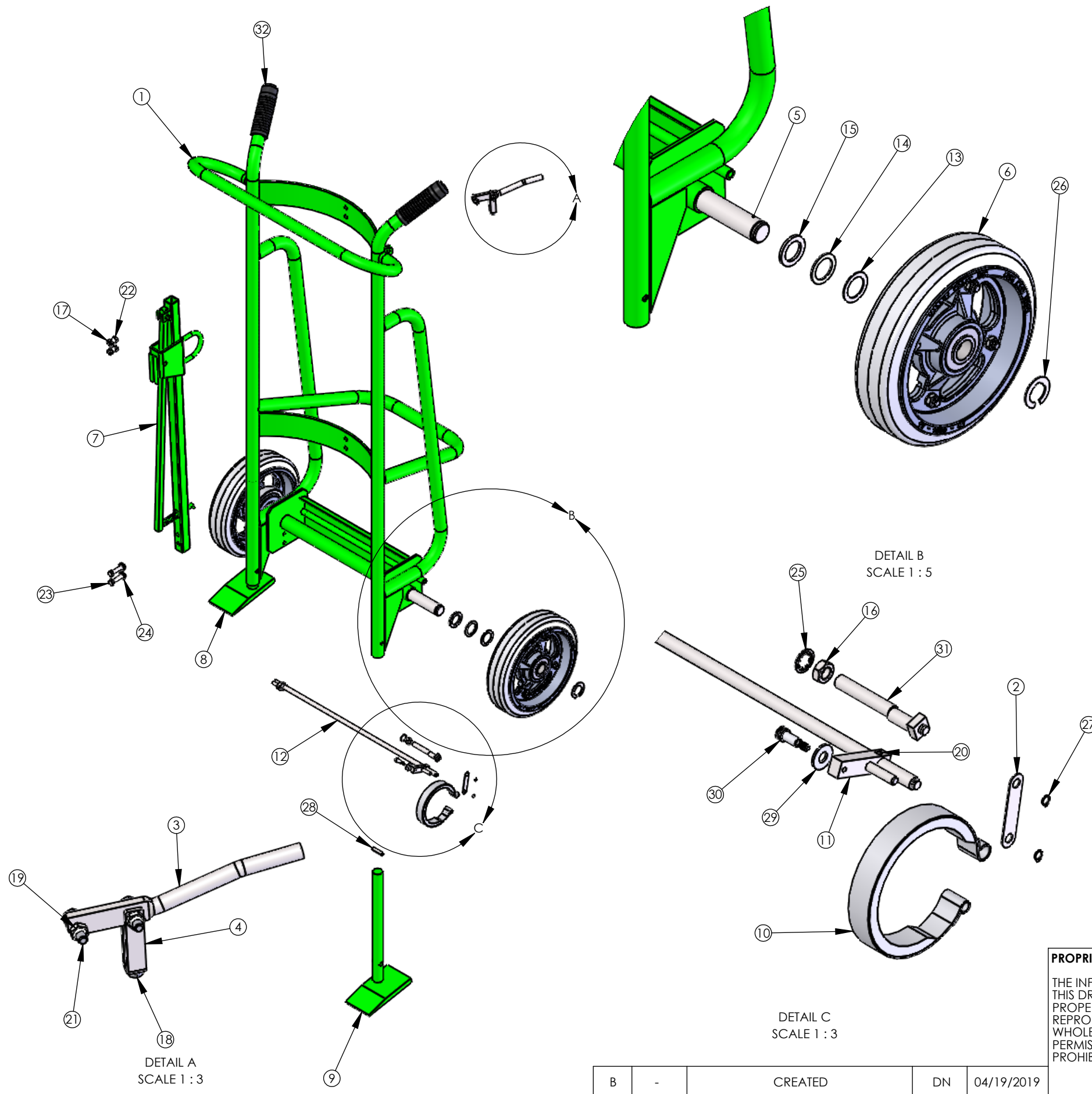

ITEM NO.	PART NUMBER	DESCRIPTION	QTY.
1	F60260A4	F W/625SS	1
2	F30012A8	LINK-CONN/825	2
3	F30013A7	HDL-BRK/825	1
4	F30014A6	CLEVIS-BRK CABLE	1
5	F30027A1	AXLE-FRT/650S	1
6	F60004A5	WHL-10 D/M	2
7	F60039B2/R60039	CHIME HOOK ASSY - STEEL --CS, use R60039 for RPMTS	1
7	F60946A6	CH ASSY-S/ CABLE	1
7	F60949A3	CH ASSY-S/ FIBER	1
7	F60947A5	CH ASSY-S/ LOCKING	1
7	F60945A7	CH ASSY-S/ PLASTIC	1
8	F60044A7/R70044	SHOE WLDMT-RH S/600 -- CS, use R70044 for RPMTS	1
9	F60045A6/R70045	SHOE WLDMT-LH S/600 -- CS, use R70045 for RPMTS	1
10	F62177A2	BRK BAND ASSY	2
11	F68656A4	BRK ROD PIN WLDMT	1
12	F68891A9	BRK ROD WLDMT-20.63	1
13	Z10011A5	BUSH-MACH 1x18Gx1-1/2 OD	2
14	Z10012A4	BUSH-MACH 1x14Gx1-1/2 OD	2
15	Z10013A3	BUSH-MACH 1x10Gx1-1/2 OD	2
16	Z10030A2	NUT-HEX JAM 3/8-24	2
17	Z10036A6	NUT-HEX KEPS 5/16-18	4
18	Z10041A9	NUT-HEX MACH #10-32	1
19	Z10043A7	NUT-NYL NE 1/4-20	2
20	Z10069A6	PIN-SPG 3/16X5/8	1
21	Z10112A3	S-HHC 1/4-20X1	2
22	Z10122A1	S-HHC 5/16-18X3/4	2
23	Z10125A8	S-HHC 5/16-18X1-1/2	2
24	Z10200A6	WASHER-1/4 FLAT USS	2
25	Z10209A7	WASHER-3/8 LOCK INT TOOTH	2
26	Z10223A9	RING-RTNG 1	2
27	Z10231A9	RING-RTNG 1/4	4
28	Z10234A6	PIN-SPG 5/16X1-1/4	2
29	Z10602A2	WASHER-1/4 FLAT SAE	1
30	Z10805A2	BOLT-STRIPPER 1/4X1/2	1
31	Z30012A2	ECC-BRK SHORT	2
32	Z50007A7	GRIP-HDL 1-1/8" BLK	2

PROPRIETARY AND CONFIDENTIAL
 THE INFORMATION CONTAINED IN THIS DRAWING IS THE SOLE PROPERTY OF VALLEY CRAFT. ANY REPRODUCTION IN PART OR AS A WHOLE WITHOUT THE WRITTEN PERMISSION OF VALLEY CRAFT IS PROHIBITED.

UNLESS OTHERWISE SPECIFIED:
 DECIMALS
 2 PLACES ±0.01
 3 PLACES ±0.005
 ANGLE ±1°
 GRIND/SAND SHARP EDGES .015 MAX
 DOES NOT APPLY TO DRILLED HOLE DIA.

VALLEYCRAFT
 2001 South Hwy. 61, Lake City, MN 55041-9555, U.S.A.
 TITLE: TRK-DRUM/625SS STD CH

B	-	CREATED	DN	04/19/2019
CHG	E.C.O.	DESCRIPTION / WAS	BY	DATE

ALL ANGLE ARE 90° UNLESS SPECIFIED

	NAME	DATE
DRAWN	DN	04/19/2019
CHECKED		
ENG APPR.		

SIZE	PART NO.	F82150A1
B	MATL:	Material <not specified>
SCALE:	1:16	WEIGHT: 65.88
		SHEET 2 OF 3

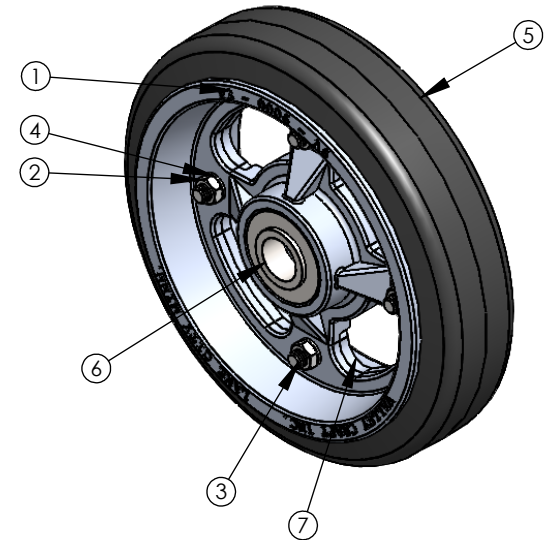
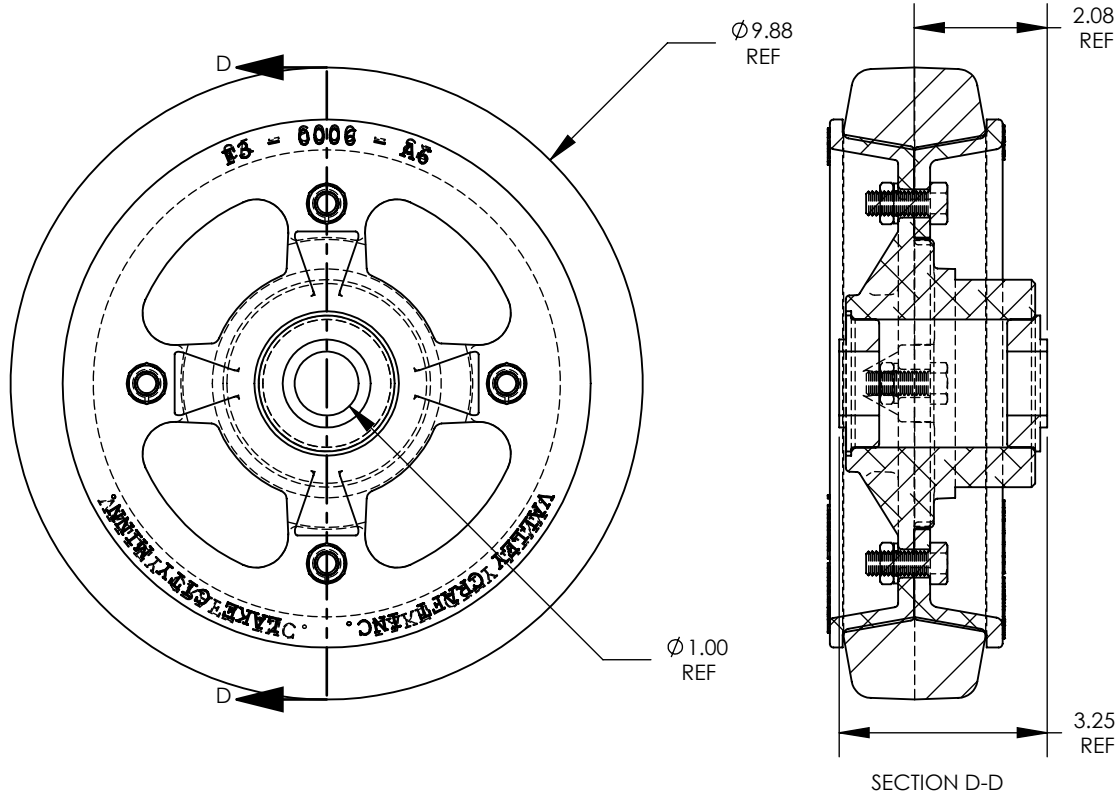

NOTES:

- △ A : 10 X 2-1/2 TIRE SIZE
- △ B : SMOOTH TREAD PATTERN
- △ C : SOFT RUBBER WHEEL MATERIAL
- △ D : 600# LOAD CAPACITY
- △ E : 8.5# WEIGHT/WHEEL
- △ F : ALUMINUM HUB MATERIAL
- △ G : BALL BEARING TYPE
- △ H : SILVER HUB COLOR

ITEM NO.	PART NUMBER	DESCRIPTION	QT. Y.
1	F30006A6	HUB-D/M 10X2.5	1
2	Z10026A8	NUT-HEX JAM 3/8-16ZP	4
3	Z10132A9	S-HHC 3/8-16X1	4
4	Z10214A0	WASHER-3/8 LOCK MD	4
5	Z30001A5	TIRE-HARD BASE D/M 10 X 2-1/2	1
6	Z30002A4	BRG-FLG 1/RPMT	2
7	Z30003A3	FLG-D/M 10X.5HD-10F	1

PROPRIETARY AND CONFIDENTIAL

THE INFORMATION CONTAINED IN THIS DRAWING IS THE SOLE PROPERTY OF VALLEY CRAFT. ANY REPRODUCTION IN PART OR AS A WHOLE WITHOUT THE WRITTEN PERMISSION OF VALLEY CRAFT IS PROHIBITED.

UNLESS OTHERWISE SPECIFIED:

DECIMALS
2 PLACES ±0.01
3 PLACES ±0.005
ANGLE ±1°

GRIND/SAND SHARP EDGES .015 MAX DOES NOT APPLY TO DRILLED HOLE DIA.



TITLE: WHL-10 D/M

NAME	DATE	SIZE	PART NO.
DRAWN JS		A	F60004A5
CHECKED			MATL:
ENG APPR.		SCALE: 1:3	WEIGHT: SHEET 3 OF 3

CHG.	E.C.O.	DESCRIPTION / WAS	BY	DATE
A	-	DRAWN	JS	01/29/2009

ALL ANGLES ARE 90° UNLESS SPECIFIED