



HANDLING
SYSTEMS
INTERNATIONAL

OWNER'S MANUAL

MODEL 313

CANTILEVER STYLE COLUMN MOUNTED JIB CRANE

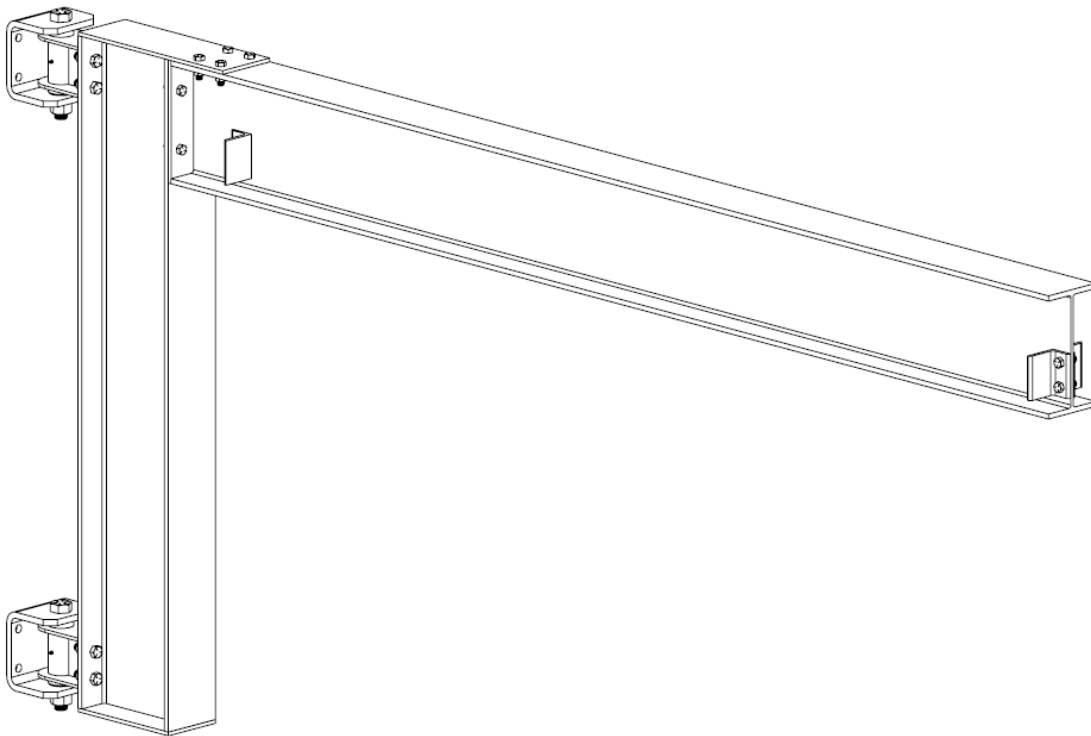

SERIAL #:

WARNING

This equipment should not be installed, operated or maintained by any person who has not read and understood all the contents of this manual. Failure to read and comply with the contents of this manual can result in serious bodily injury or death, and/or property damage.

PHONE (888) 352-1213 • FAX (708) 352-6593 • McCook, IL

Table of Contents

<u>Section</u>	<u>Page Number</u>
Important Information and Warnings.....	3
Technical Information and Specifications.....	4
Crane Terms.....	5
Installation Instructions.....	8
Rotation Stops (If Applicable).....	10
Tight Wire Kit (If Applicable).....	11
Operation Introduction.....	12
Shall's and Shall Not's for Operation.....	13
Maintenance Inspection.....	14
Lubrication.....	15
Troubleshooting.....	16
Warranty.....	17
Parts Information.....	18
Parts Breakdown.....	19

WARNING

ONLY COMPETENT ERECTION PERSONNEL FAMILIAR WITH STANDARD FABRICATION PRACTICES SHOULD BE EMPLOYED TO ASSEMBLE HANDLING SYSTEMS CRANES BECAUSE OF NECESSITY IN INTERPRETING THESE INSTRUCTIONS. HANDLING SYSTEMS IS NOT RESPONSIBLE FOR QUALITY OF WORKMANSHIP PERFORMED DURING CRANE INSTALLATION.

WARNING

ALL HANDLING SYSTEMS EQUIPMENT IS NOT DESIGNED FOR OR MADE FOR TRANSPORTING HUMANS. FAILURE TO COMPLY WITH ANY ONE OF THE LIMITATIONS STATED IN THIS CRANE MANUAL CAN RESULT IN PROPERTY DAMAGE, INJURY, OR DEATH. PLEASE TAKE ALL NECESSARY PRECAUTIONS DURING INSTALLATION.

WARNING

CONSULT WITH A QUALIFIED STRUCTURAL ENGINEER TO DETERMINE IF YOUR SUPPORT STRUCTURE IS ADEQUATE TO SUPPORT THE LOADS GENERATED BY ANCHOR BOLT FORCE, OVERTURNING MOMENT, OR AXIAL LOAD OF YOUR CRANE.

WARNING

CRANE CANNOT BE UTILIZED AS A GROUND: A SEPARATE GROUND WIRE IS REQUIRED.

WARNING

DO NOT MODIFY CRANE IN ANY WAY. ANY ALTERATIONS DONE IN THE FIELD WITHOUT CONSENT FROM HANDLING SYSTEMS WILL VOID ALL WARRANTY.

WARNING

OVERLOADING AND IMPROPER USE CAN RESULT IN INJURY

WARNING

- MANUAL MUST BE FULLY READ AND UNDERSTOOD BY QUALIFIED ERECTION PERSONNEL PRIOR TO INSTALLATION AND USE OF PRODUCT.
- CRANE IS NOT DESIGNED FOR AND SHOULD NOT BE USED FOR LIFTING OR TRANSPORTING HUMANS
- CRANE CAN NOT BE UTILIZED AS A GROUND.
- DO NOT FIELD MODIFY CRANE IN ANY WAY
- CONSULT WITH QUALIFIED STRUCTURAL ENGINEER TO DETERMINE IF JIB CRANE SUPPORT STRUCTURE IS ADEQUATE BASED ON THE LOADS GENERATED BY THE JIB CRANE



Technical Information and Specifications

Product Code for Cantilever Jib

(Cantilever Jib includes 752 fitting kit, boom, stem, boom/stem connection hardware, end stops, and end stop hardware. Mounting hardware is supplied by others.)

313 - 1000 - 08

Type of Column/Wall Mounted Jib Crane:
313 - Cantilever Style

Capacity Code
(examples):
500 = 500lbs (1/4 Ton)
1000 = 1,000lbs (1/2 Ton)
2000 = 2,000lbs (1 Ton)
4000 = 4,000lbs (2 Ton)
6000 = 6,000lbs (3 Ton)

Span (examples):
08 = 8ft
10 = 10ft
20 = 20ft

Product Code for Cantilever Jib Fitting Kit

(Fitting Kit includes fittings only. This kit is for customers providing boom, stem, boom/stem connection hardware, mounting hardware, etc.)

752 - 4

Model Type:
752 - Fitting Kit

Fitting Style & Size
(examples):
4 - Cantilever Style: J1
5 - Cantilever Style: J2
6 - Cantilever Style: J3

Crane Terms

In order to better understand jib cranes, here are the commonly used terms that are used to specify and design jibs.

- **Anchor Bolts:** Large steel bolts used to mount a base mounted pillar jib crane to the H.S.I. recommended foundation.
- **Boom:** The horizontal beam on which the hoist trolley travels.
- **Fitting Centers:** The distance, centerline to centerline, between two support brackets (fittings) of a wall mounted jib crane.
- **Capacity:** The maximum live weight that the crane is designed to support.
- **End Stops:** Bolted to each end of the boom to prevent the trolley from falling off of the beam.
- **Foundation:** For free standing pillar base mounted jibs. Foundations are used to support the jib and prevent it from tipping over.
- **Gussets:** Reinforcing plates used to stiffen mast at the base plate.
- **Head:** Houses the roller, and lowers the crushing forces that are imposed on the mast.
- **Height Under the Boom (H.U.B.):** The distance from the finished floor to the underside of the crane boom. To find the under-boom, take the height of the load, plus the distance the load is lifted, plus the headroom requirements of the hoist/trolley and any attachments. Extra room aside from mandatory room needed could be helpful.
- **Mast:** The vertical member of the jib, which supports the crane. Pillar jibs have round pipes as masts.
- **Overall Height:** The highest point of the jib crane (including any hardware). A minimum clearance (usually 3") is required from any overhead obstruction.
- **Hoist:** The actual lifting mechanism (powered by electric, air, or manual movement) that hangs from the trolley that rides on the boom of a jib crane.
- **Trolley:** The mechanism that travels back and forth on the crane boom (powered by electric, air, or manual movement) which the hoist hangs from.
- **Overtipping Moment:** The overturning moment is the force applied to the mounting structure of a self-supporting pillar jib. This load is created by suspending a load from the boom, and is greatest at full load, at the very end of the boom.
- **Rotation Stops:** Limits the rotation of a pillar base mounted jib crane boom (which are standard at 360°). Stops are field welded to the mast.
- **Span:** The span for a pillar base mounted jib crane is the distance from the center of the mast to the end of the boom. The span for a column mounted crane is measured from the face of the mounting surface to the end of the boom. The span for a mast type jib crane is measured from the center of the vertical mast to the end of the boom.
- **Thrust and Pull:** Thrust and Pull are forces applied to a wall/column mounted jib cranes support structure. Thrust is the pushing force exerted on the structure, and pull is the tensile, or pulling force. Thrust and Pull are equal to each other (but opposite in direction), and are given for maximum at full load at the end of the boom.
- **Clear Span:** The measurement between the end stops on a crane boom.
- **Hook Travel:** The distance that the hook on the hoist travels.

This Page Left Intentionally Blank

This Page Left Intentionally Blank

Pre-Installation

1. There must be an adequate wall, column, or truss to support the jib crane. Consult a qualified structural engineer to determine if the support structure is adequate to support the thrust and pull of your crane (See **Crane Drawing** for Thrust and Pull)
2. Ensure there will be sufficient clearance (3" minimum) above the boom throughout the rotation.
3. Check jib crane for physical damage due to shipping.
4. Ensure all capacity stickers and warning labels are clearly visible and properly affixed.
5. Check packing list to ensure no parts have been lost prior to initiating assembly of crane.
6. See Jib Crane Drawing for bolt locations and dimensions.
7. Read entire manual before installing the crane.

Installation

1. If multiple cranes were ordered, locate stamped serial number on each crane part for proper part matching during installation. Although crane parts may appear to be identical, each crane is assembled and built separately. All parts that do not have the same stamped serial number may not line up properly for installation.
2. Reference Jib Crane Drawing included in the crane information packet.
3. Make sure the support structure (COLUMN) is plumb for installation. Prepare the COLUMN for jib fittings.
5. Use the Crane Drawing as a guide to determine the bracket hole layout for the TOP FITTING bracket and BOTTOM FITTING bracket. Make sure the bracket holes are properly aligned.
6. Drill bolt holes for the TOP FITTING bracket and BOTTOM FITTING bracket, and bolt them to supporting structure (COLUMN). Do not torque bolts until brackets are plumb. See **Figure 1**. Note: Hardware to bolt fittings to COLUMN is supplied by others.
7. Plumb TOP FITTING and BOTTOM FITTING through pivot holes. If necessary, shim between COLUMN and fittings (shims by others).

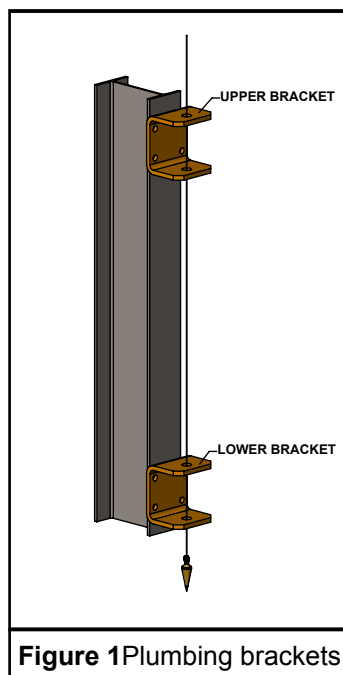
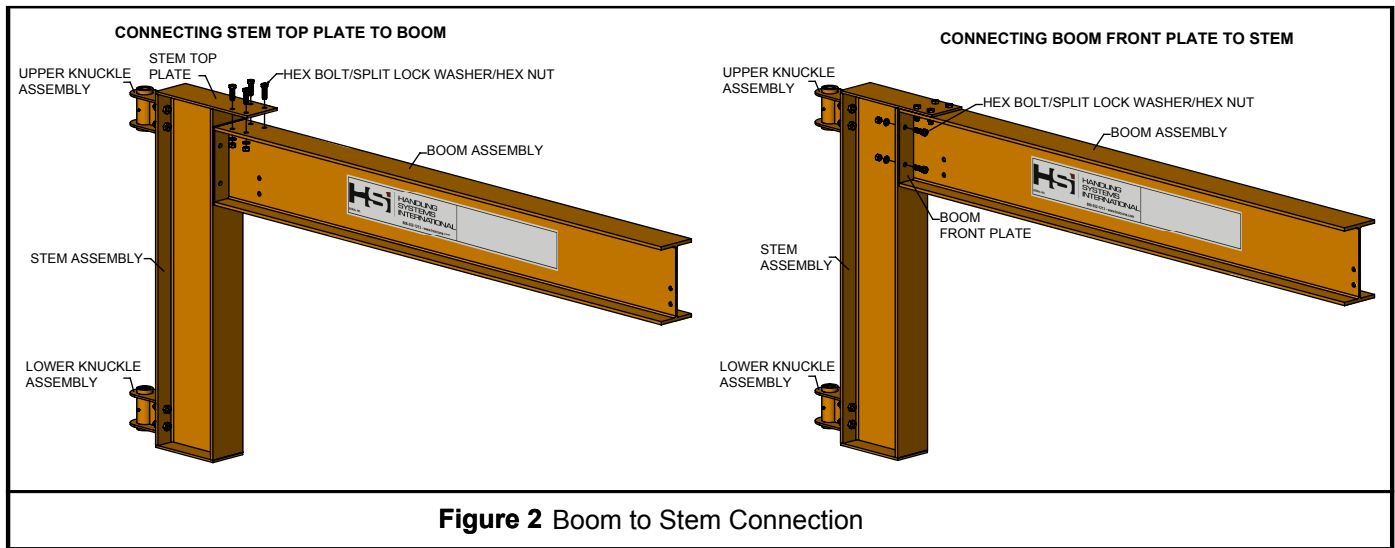

Figure 1 Plumbing brackets

- Bolt upper and lower knuckle assemblies to stem beam. Refer to Jib Crane Drawing for hardware sizes and locations. For Torque Values, see **Table 1**. Connect stem top plate to boom and connect boom front plate to stem - See **Figure 2**. If stem and boom are welded together, skip to Step 9.



- Raise jib into position and attach to wall bracket using hardware provided (see **Figure 3**). Tighten nuts on hex bolt until lockwashers are compressed, being sure boom rotates freely.

BOLT DIA.	TORQUE (ft.-lbs.)
1/4"-20	6
3/18"-16	20
1/2"-13	50
5/8"-11	95
3/4"-10	175
7/8"-9	300

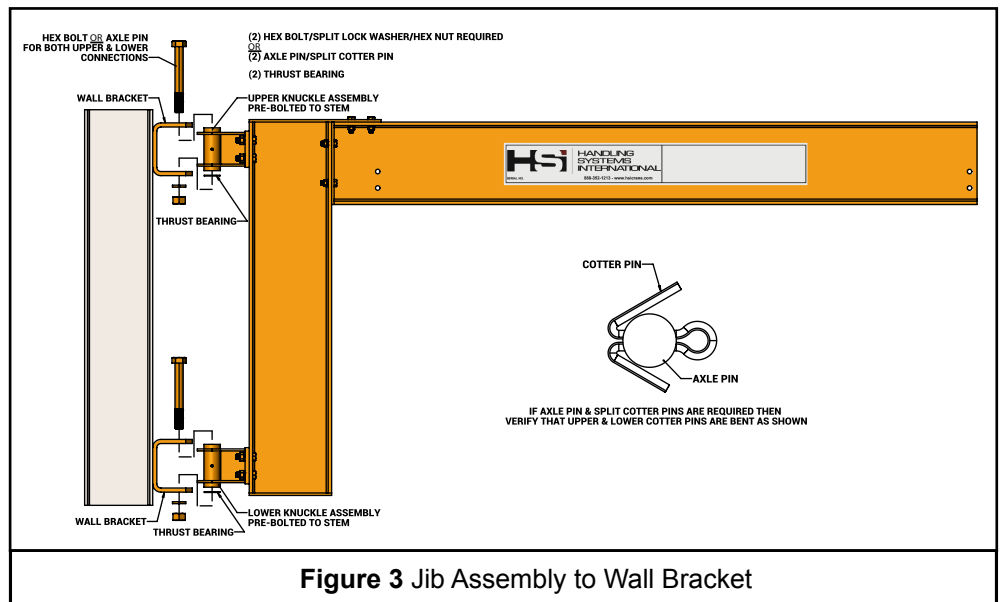

- Check jib for “plumbness” by permitting crane to swing freely. Make adjustments where needed by shimming between supporting structure (COLUMN) and TOP and/or BOTTOM FITTINGS.
- Ensure all fittings are greased.
- Check rotation of jib for alignment, binds, or slow-downs. Make sure all obstructions or interferences are removed.

NOTE: SHIMS CAN BE ADDED TO ADJUST TIP OF BOOM ELEVATION TO PROPER LEVEL IN BETWEEN CANTILEVER FITTING AND STEM CONNECTION AND/OR FRONT PORTION OF STEM PLATE TO BOOM BOLTED CONNECTION

13. If applicable, install MECHANICAL ROTATION STOPS

INCLUDES (2) ROTATION STOPS

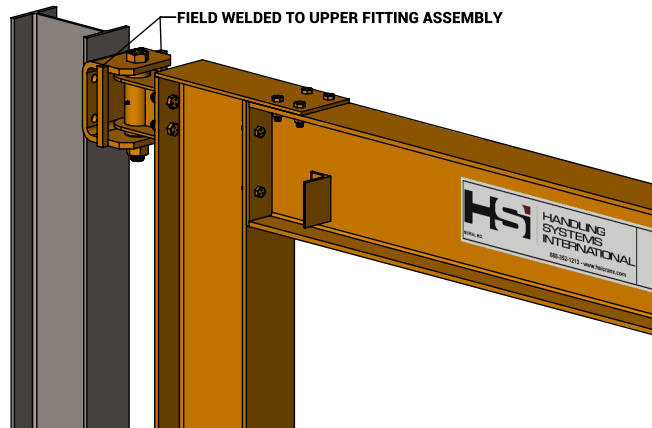

14. Bolt two inner END STOPS to BOOM. Slide trolley hoist on BOOM, then bolt two remaining END STOPS to BOOM. Make sure trolley hoist hits the END STOP and not the jib STEM. Move END STOPS to correct location if needed. (For units with Tight Wire Kit, refer to **Page 11**).

(4) HEX BOLT/SPLIT LOCK WASHER/HEX NUT REQUIRED

(4) END STOPS

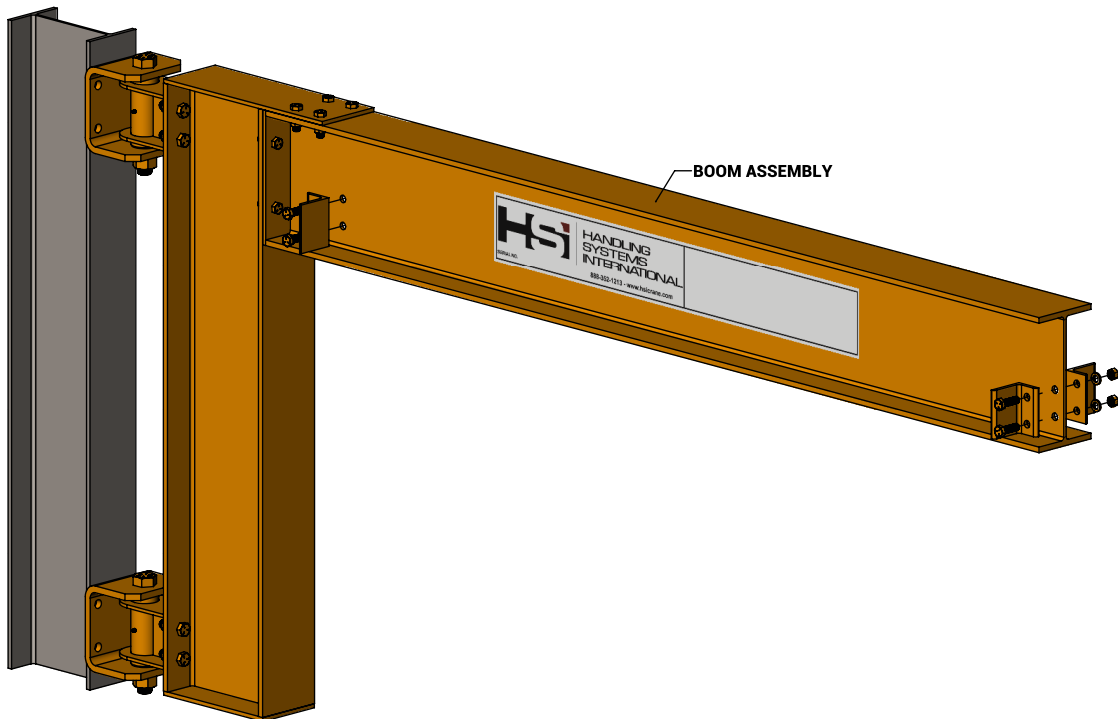

9990000

A

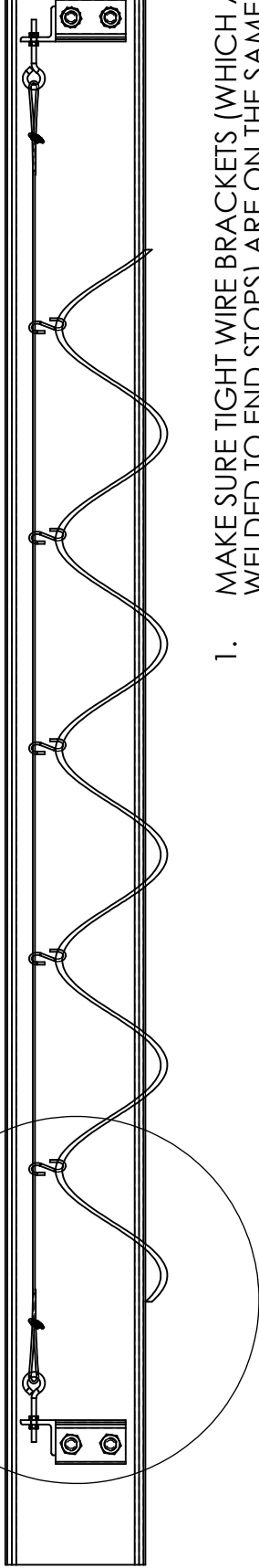

1. MAKE SURE TIGHT WIRE BRACKETS (WHICH ARE WELDED TO END STOPS) ARE ON THE SAME SIDE OF BOOM.
2. LOOP CABLE THROUGH EYE BOLT AT ONE END. TIGHTEN WITH CABLE CLAMP. PUT "S" HOOKS ON CABLE. LOOP CABLE THROUGH OTHER EYE BOLT. TIGHTEN WITH CABLE CLAMP.
3. SLIP EYE BOLT THROUGH TIGHT WIRE BRACKET AND TIGHTEN EYE BOLT UNTIL TIGHT WIRE IS TIGHT.
4. **NOTE: 361 MODEL JIB ONLY REAR TIGHT WIRE BRACKET IS BOLTED TO REAR GUSSET ON BOOM.
5. **NOTE: FOR CRANES WITH 6" BEAM TIGHT WIRE BRACKET MAY HAVE DIFFERENT ORIENTATION DUE TO SPACE CONSTRAINTS.

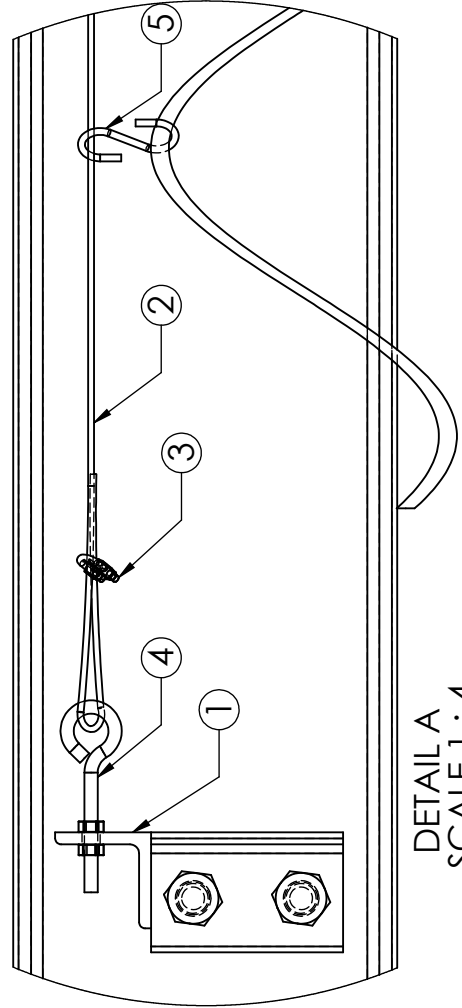
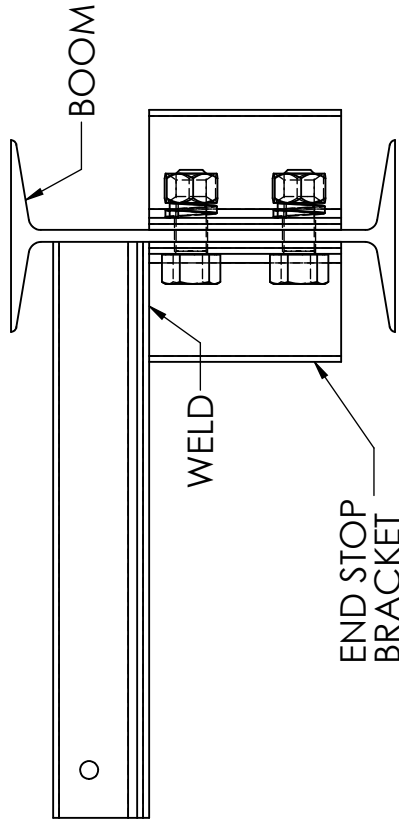

DETAIL A
SCALE 1 : 4

ITEM NO.	DESCRIPTION	QTY.
1	TIGHT WIRE ANGLES (WELDED TO ES)	2
2	1/8" DIA CABLE (LENGTH = CRANE SPAN)	1
3	CABLE CLAMPS	2
4	5/16" EYE BOLTS W/ NUTS	2
5	"S" HOOKS	#

HANDLING SYSTEMS INTERNATIONAL
L.AGRANGE, IL 60525

DESCRIPTION TIGHT WIRE ASSEMBLY

PART NUMBER 9990000 MATERIAL

DRAWN BY D. Grujic DATE DRAWN 05/02/07 DRAWING SIZE A SHEET NUMBER 1 SCALE: 1:10

TOLERANCES: DECIMALS (UNLESS OTHERWISE SPECIFIED) TWO PLACE (.00) + .015 THREE (.000) + .005 INC. ANY REPRODUCTION IN PART OR AS A WHOLE WITHOUT THE WRITTEN PERMISSION OF HANDLING SYSTEMS INTERNATIONAL, INC. IS PROHIBITED. ANGLES +/- 30 MINUTES. ALL DIMENSIONS ARE IN INCHES UNLESS OTHERWISE SPECIFIED.

Operation Introduction

The suggestions below are not intended to take precedence over existing plant safety rules and regulations or OSHA regulations. It is the responsibility of the owner to make personnel aware of all federal, state and local rules and codes, and to make certain operators are properly trained.

DANGER

DO NOT WALK UNDER A SUSPENDED LOAD
KEEP HANDS CLEAR OF ROTATING PARTS

WARNING

CRANE OPERATORS SHALL BE REQUIRED TO READ THE OPERATION SECTION OF THIS MANUAL, THE WARNINGS CONTAINED IN THIS MANUAL, INSTRUCTION AND WARNING LABELS ON THE HOIST OR LIFTING SYSTEM, APPLICABLE ANSI AND OSHA SAFETY STANDARDS, AND THE CRANE OPERATOR'S MANUAL PUBLISHED BY THE CRANE MANUFACTURER'S ASSOCIATION OF AMERICA (CMAA). THE OPERATOR SHALL ALSO BE REQUIRED TO BE FAMILIAR WITH THE CRANE AND CRANE CONTROLS BEFORE BEING AUTHORIZED TO OPERATE THE CRANE OR LIFTING SYSTEM.

CRANE OPERATORS SHOULD BE TRAINED IN PROPER RIGGING PROCEDURES FOR THE ATTACHMENT OF LOADS TO THE HOIST HOOK.

CRANE OPERATORS SHOULD BE TRAINED TO BE AWARE OF POTENTIAL MALFUNCTIONS OF THE EQUIPMENT THAT REQUIRE ADJUSTMENT OR REPAIR, AND TO BE INSTRUCTED TO STOP OPERATION IF SUCH MALFUNCTIONS OCCUR, AND TO IMMEDIATELY ADVISE THEIR SUPERVISOR SO CORRECTIVE ACTION CAN BE TAKEN.

CRANE OPERATORS SHOULD HAVE NORMAL DEPTH PERCEPTION, FIELD OF VISION, REACTION TIME, MANUAL DEXTERITY, HEARING, AND COORDINATION.

CRANE OPERATORS SHOULD NOT HAVE A HISTORY OF OR BE PRONE TO SEIZURES, LOSS OF PHYSICAL CONTROL, PHYSICAL DEFECTS, OR EMOTIONAL INSTABILITY THAT COULD RESULT IN ACTIONS OF THE OPERATOR BEING A HAZARD TO THE OPERATOR OR TO OTHERS.

CRANE OPERATORS SHOULD NOT OPERATE A CRANE OR LIFTING SYSTEM WHEN UNDER THE INFLUENCE OF ALCOHOL, DRUGS, OR MEDICATION.

NOTICE

Read OSHA Specification 1910.179 "Overhead and Gantry Cranes," ANSI B30.11, "Monorails and Underhung Cranes," ASMEB30.16, and any other applicable standards.

Read the hoist manufacturer's Operating and Maintenance Instructions.

Read all labels attached to equipment.

Shall's and Shall Not's for Operation

WARNING

Improper operation of a crane can create a potentially hazardous situation which, if not avoided, could result in death or serious injury, and substantial property damage. To avoid such a potentially hazardous situation **THE OPERATOR SHALL:**

- **NOT** operate a damaged, malfunctioning or unusually performing crane.
- **NOT** operate a crane until you have thoroughly read and understood Manufacturer's Operating and Maintenance Instructions or Manuals.
- Be familiar with operating controls, procedures, and warnings.
- **NOT** operate a crane that has been modified without the manufacturer's approval.
- **NOT** lift more than rated load for the crane/hoist/trolley.
- **NOT** use the crane to lift, support, or transport people.
- **NOT** lift loads over people.
- **NOT** operate a crane unless all persons are and remain clear of the supported load.
- **NOT** operate unless load is centered under hoist.
- **NOT** leave load supported by the crane/hoist unattended unless specific precautions have been taken.
- **NOT** allow the crane to be used as an electrical or welding ground.
- **NOT** remove or obscure the warnings on the crane.
- **NOT** operate a crane on which the safety placards or decals are missing or illegible.
- **NOT** operate a crane that has any changes in rolling effort or unusual noises.
- Warn personnel before lifting or moving a load.
- Warn personnel of an approaching load.
- Ensure that end-stops are in place.
- Ensure that all bolts are tight and have lockwashers.
- **NOT** put hands near rotating parts.

WARNING

Improper operation of a crane can create a potentially hazardous situation which, if not avoided, could result in minor or moderate injury, or property damage. To avoid such a potentially hazardous situation **THE OPERATOR SHALL:**

- Maintain a firm footing or be otherwise secured when operating the crane.
- Make sure the load is free to move and will clear all obstructions.
- Avoid swinging the load or hook.
- Inspect the crane regularly, replace damaged or worn parts, and keep appropriate records of maintenance.
- Use the crane manufacturer's recommended parts when repairing the unit.
- Lubricate the roller bearings per crane manufacturer's recommendations.
- **NOT** allow your attention to be diverted from operating the crane.
- **NOT** allow the crane to be subjected to sharp contact with other cranes, structures, or objects through misuse.
- **NOT** adjust or repair the crane unless qualified to perform such adjustments or repairs.
- Ensure that festooning cannot be snagged or pinched.

JIB BOOM OPERATION

- Verify the hook is high enough to clear any obstruction before using the boom of the jib crane.
- Ensure the jib boom is directly over the load before lifting the load.
- Start moving the jib boom slowly and bring it up to speed gradually.
- Reduce the speed of the boom as it approaches the place where it should stop.

TROLLEY OPERATION

- Refer to the trolley's operating instructions.

HOIST OPERATION

- Refer to the hoist's operating instructions.

Maintenance Inspection

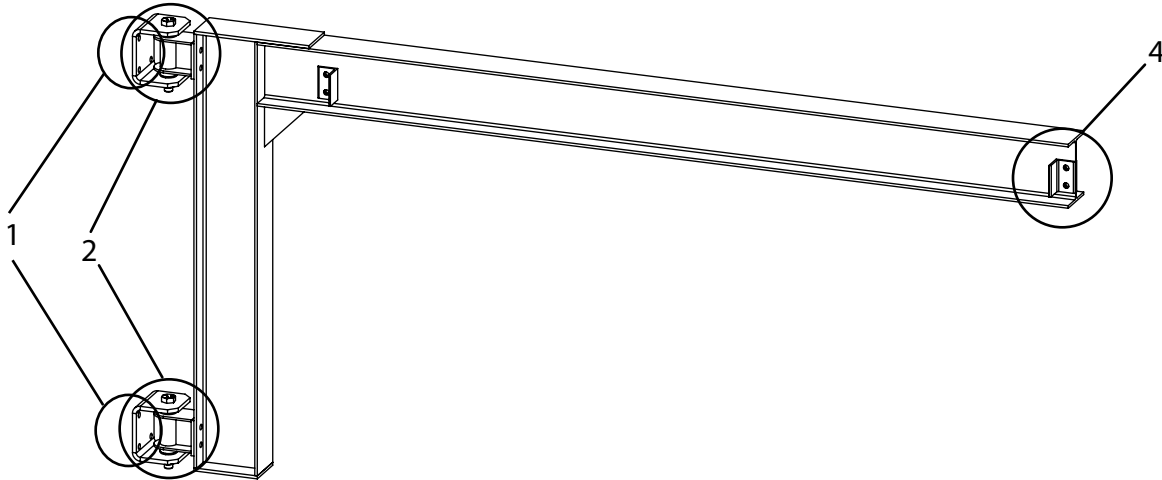

Crane Inspection

Figure No.	Item	Inspection	Frequency
1	Mounting Bolts	Check that the lock-washers are fully compressed and the nuts are tightened to manufacturer's specifications.	Every 500 hours Or 3 months
2	Fitting Assemblies	For connection from fittings to beam face and flange – check that the lock-washers are fully compressed and the nuts are tightened to the proper torque specs from Table 1 . Make sure cotter pin/bolt is securely fastened into fitting pin hole. Lubricate fittings per Page 13	Every 500 hours Or 3 months
3	Stem to Boom Connection	Check that the lock-washers are fully compressed and the nuts are tightened to the proper torque specs from Table 1 .	Every 500 hours Or 3 months
4	End Stop/Tight Wire Kit	Check that the lock-washers are fully compressed and the nuts are tightened to the proper torque specs from Table 1 .	Every 500 hours Or 3 months
-	Additional Items	Conduct a general inspection of all additional items purchased.	Every 1000 hours Or 6 months
-	General	Conduct a visual inspection of the overall crane and check any operator reports. If any flaws or problems are found, the crane should be taken out of service and reported to manufacturer immediately.	Every 500 hours Or 6 months

WARNING

Any changes in rolling effort or unusual noises must be immediately identified and corrected

Lubrication

1. The most economical way to maintain a jib crane and keep it in good operating condition is to lubricate all moving parts regularly.
2. Regular inspection of all parts should be made and all loose parts should be adjusted. Parts that become worn should be replaced immediately.
3. The lubrication interval varies with the use of the machine. A crane operating 24 hours a day, 7 days a week, should demand lubrication once a week. Whereas a standard duty crane, operating eight hours a day on a five day week should be lubricated once every two to three weeks. Cranes under a standby classification, being used once or twice a month, should be lubricated at least once every six months.
4. The actual interval from one lubrication to the next depends entirely upon the type and length of operation to which the crane is subjected. These factors are variable and sometimes cannot be definitely determined. In this case, the crane operator or maintenance engineer would determine when the crane should be lubricated.
5. The roller bearings on the jib crane require lubrication. They are serviced by pressure type fittings.
6. The recommended lubricants for these bearings are:
 - a. Texaco Marfax No. 0 for below 32 degrees F
 - b. Texaco Marfax No. 1 for above 32 degrees F
7. If Texaco products are not available, equivalent lubricants are satisfactory.

Troubleshooting

Troubleshooting Guide		
Symptom	Possible Cause	Remedy
Boom is drifting	Fittings are not plumb	Shim between supporting structure and fittings accordingly
	Fittings are misaligned	Align fitting holes properly
Does not rotate smoothly	Debris in bearings	Remove debris
	Fittings are misaligned	Align fitting holes properly
Does not rotate a complete rotation	Crane boom has an obstruction	Remove any obstruction



11 Year Warranty

HSI's 11 year warranty is the best in the industry.

What Products Are Covered?

- Manual Rotation Jib Cranes
- Manual Steel Gantry Cranes
- Defects in material and workmanship

The Fine Print:

Handling Systems International, Inc. (known as H.S.I.) warrants manual push/pull Jib and Gantry Crane products it manufactures against defects in material or workmanship for a period of eleven years from date of receipt by purchaser or customer. This warranty does not cover failure or defect in paint or material finish. This warranty does not cover failure or defect caused by operation in excess of recommended rated capacities, misuses, negligence or accident, and alteration or repair of any kind not authorized by H.S.I. H.S.I. systems shall not be modified after manufacture without written authorization of H.S.I. Any field modifications made without written authorization of H.S.I. shall void all H.S.I.'s warranty obligation. H.S.I. agrees to furnish the same or substantially similar replacement part (new or repaired) free of charge, providing the buyer gives immediate written notice of alleged defects, and if requested by H.S.I., returns the defective parts to the factory, for H.S.I.'s inspection and examination. Purchaser or end user shall be solely responsible for all freight and transportation costs incurred in connection with any warranty work provided by H.S.I. hereunder. H.S.I. will not be liable for any loss, injury or damage to persons or property, nor for damages of any kind resulting from failure or defective operation of any materials or equipment furnished hereunder. H.S.I. shall not be liable under any circumstances for any incidental, special and/or consequential damages whatsoever, whether or not foreseeable, including but not limited to damages for lost profits and all such incidental, special and/or consequential damages are hereby also specifically disclaimed. This warranty applies only to H.S.I. equipment or materials which, after our inspection, are determined to be defective either in material supplied or workmanship performed by H.S.I. Where equipment is furnished by H.S.I. but not of its manufacture, H.S.I.'s liability is limited to such adjustment as the actual manufacturer makes to H.S.I. H.S.I. will not be liable for the cost of repairs, alterations, or replacements or any expense connected therewith made or incurred by the purchaser or his agents or employees, except upon written authority from H.S.I. This warranty is personal to purchaser only and applies only to equipment which purchaser has properly operated and maintained in accordance with H.S.I.'s written instructions. H.S.I. assumes no liability for any consequential damages suffered through the use of loss of use of its equipment. This constitutes H.S.I.'s sole warranty with respect to the equipment and material manufactured by itself. H.S.I. makes no other warranty of any kind whatsoever, expressed or implied, and all implied warranties of merchantability and fitness for a particular purpose which exceed the aforementioned obligation are hereby disclaimed by H.S.I.

Parts Information

When ordering Parts, please provide the crane serial number which is stamped into each crane part (see **Figure 5**). The serial number is also located underneath the “HSI” logo.

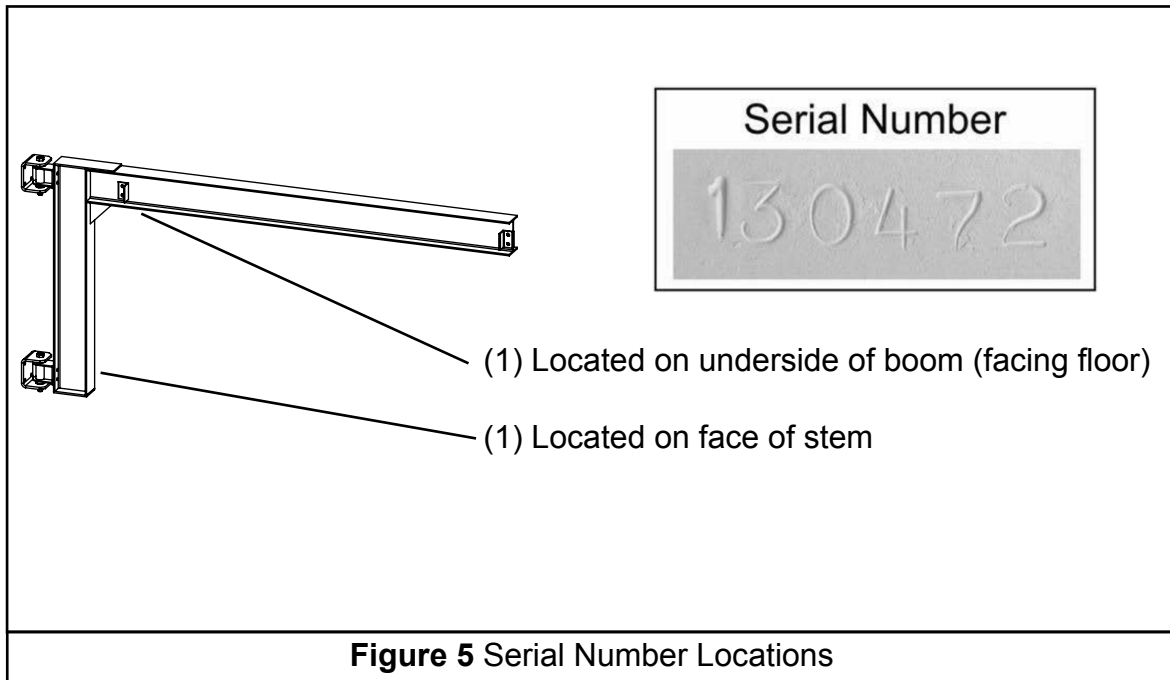

Parts Breakdown

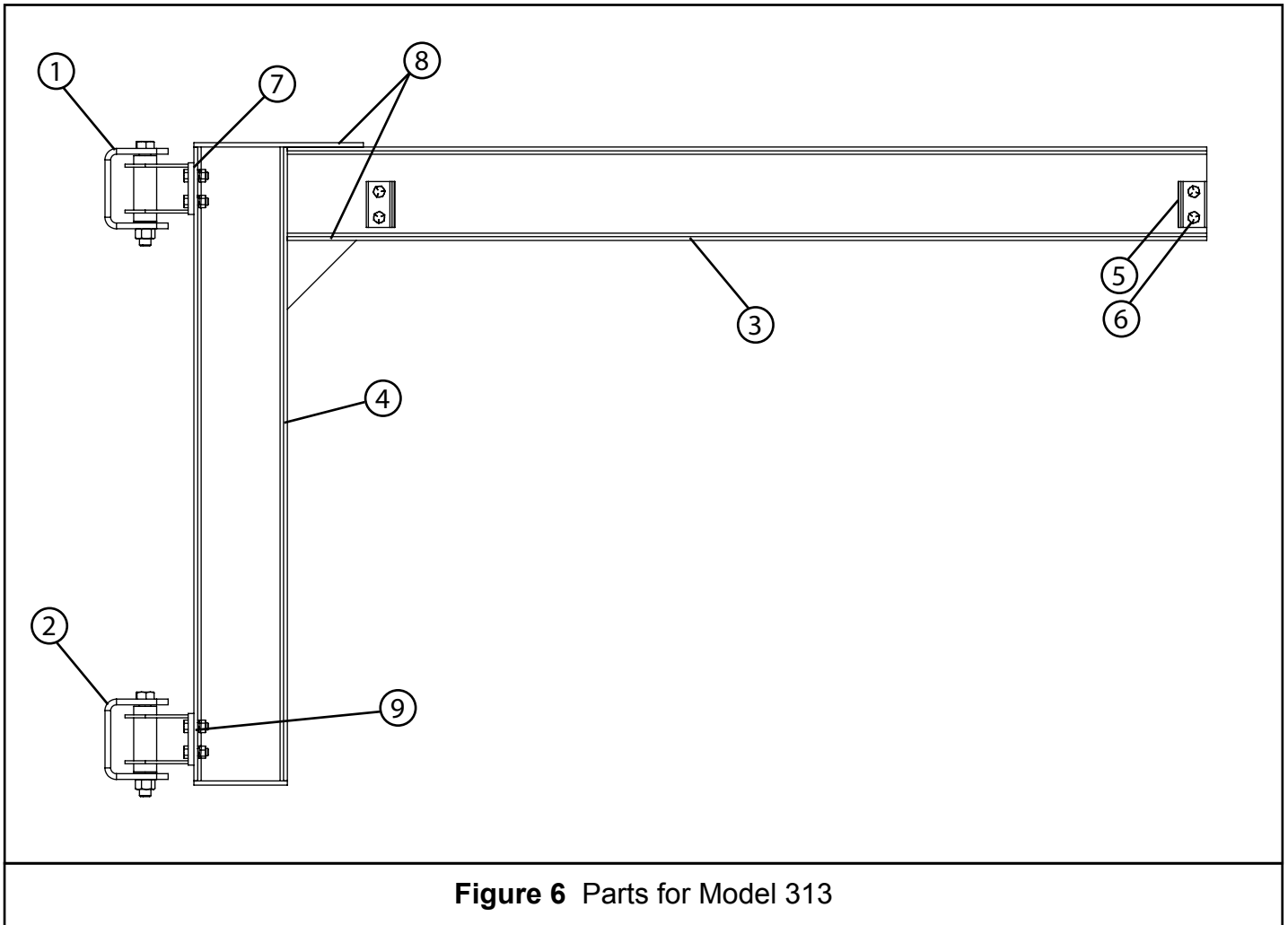

**This figure is for reference only; actual crane may look different*

Figure No.	Description	Qty
1	Top Fitting*	1
2	Bottom Fitting*	1
3	Boom Assembly	1
4	Stem Assembly	1
5	End Stops	4
6	End Stop Hardware	-
7	Top Fitting Hardware	-
8	Boom To Stem Hardware	-
9	Bottom Fitting Hardware	-

**Mounting Hardware is supplied by others*



www.hsicrane.com

Handling Systems Intl. Inc.
8000 Joliet Rd.
McCook, IL 60525

(888) 352-1213 Toll Free