

THREE STEP, ALUMINUM, CROSS OVER - COL-AL-3-26-44

APPROX WEIGHT: 172.43 lbs.
 DOES NOT INCLUDE WEIGHT OF POWER OR PACKAGING!!!

*** ANY ADDITIONS, DELETIONS, OR OMISSIONS MUST BE CORRECTED ON THIS DRAWING AS THIS DRAWING WILL BE CONSIDERED ALL INCLUSIVE ***
 ALL GRAPHICS PROVIDED ARE FOR REFERENCE ONLY. IF CERTAIN DIMENSIONS ARE CRITICAL PLEASE VERIFY THOSE DIMENSIONS WITH YOUR SALESPERSON

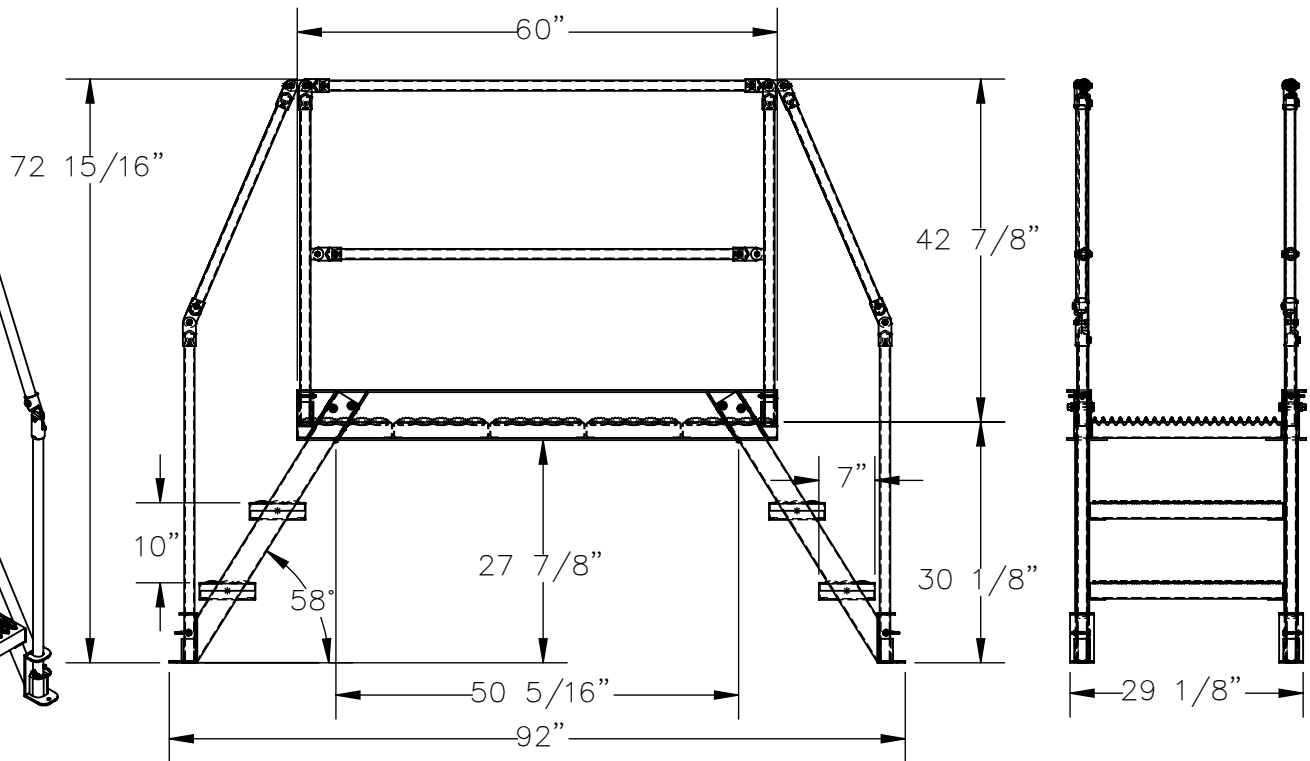
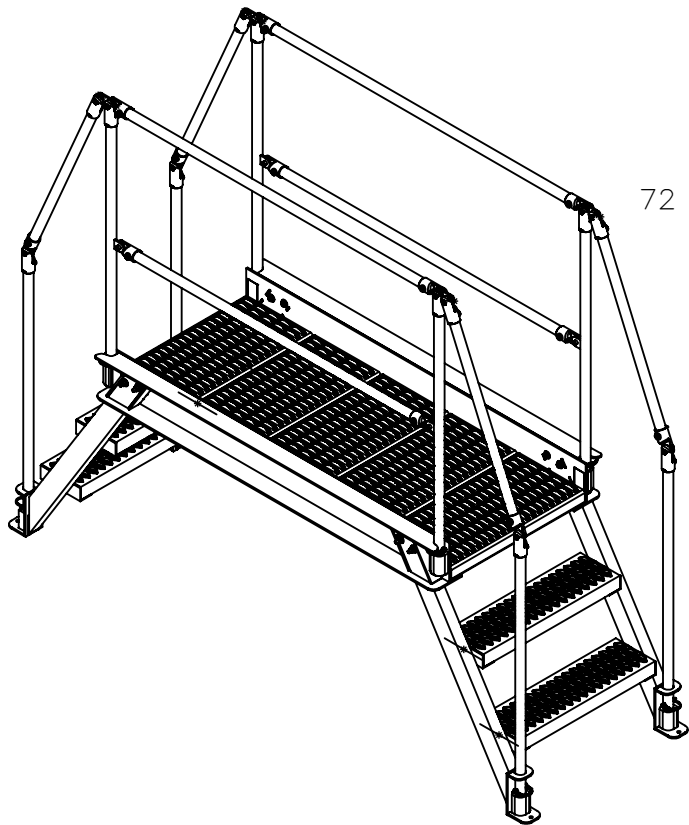

DIMENSION TOLERANCE ± 1/4"

STANDARD FEATURES:

MODEL NUMBER: COL-AL-3-26-44
 OVERALL SIZE
 29 1/8" W x 92" L x 72 15/16" H
 CLEARANCE SPAN:
 50 5/16" W x 27 7/8" H
 TOP PLATFORM HEIGHT: 30 1/8"
 STEP HEIGHT SPACING: 10"
 STEP DEPTH: 7"
 STEP & PLATFORM WIDTH: 29 1/8"
 CLIMB ANGLE: 58°
 OVERALL CAPACITY: 500 LBS.
 ALUMINUM CONSTRUCTION

SPECIAL FEATURES:

NONE

APPROVAL

I, THE UNDERSIGNED, AGREE THAT THE PRODUCT AS REPRESENTED SATISFIES DESIGN AND DIMENSION REQUIREMENTS. I ALSO ACKNOWLEDGE MY DUTY TO CONFIRM PRODUCT AND INSTALLATION COMPLIANCE WITH ALL APPLICABLE FEDERAL, STATE AND LOCAL REGULATIONS AND STANDARDS.
UNITS REQUIRING APPROVAL DRAWINGS OR MODIFIED ARE NON-RETURNABLE

As drawn As marked

Signed: _____ Date: _____

Printed Name: _____

LEAD TIME WILL START UPON RECEIPT OF SIGNED APPROVAL DRAWING

DISTRIBUTOR'S NAME:		P.O.#
VESTIL MANUFACTURING		X
DRAWN BY: T. HARKRADER		W.O.#
DATE: 8/25/21		X
REFERENCE: X	SCALE: 1:24	SALES: X
QUOTED LEAD TIME: X	QUOTE #	FILE NAME:
	X	44-007-768