

# ADJUSTABLE STEEL GANTRY CRANE - AHS-2-15-10

APPROX WEIGHT: 718.98 lbs.  
DOES NOT INCLUDE WEIGHT OF POWER OR PACKAGING!!!

\*\*\* ANY ADDITIONS, DELETIONS, OR OMISSIONS MUST BE CORRECTED ON THIS DRAWING AS THIS DRAWING WILL BE CONSIDERED ALL INCLUSIVE \*\*\*

ALL GRAPHICS PROVIDED ARE FOR REFERENCE ONLY. IF CERTAIN DIMENSIONS ARE CRITICAL PLEASE VERIFY THOSE DIMENSIONS WITH YOUR SALESPERSON

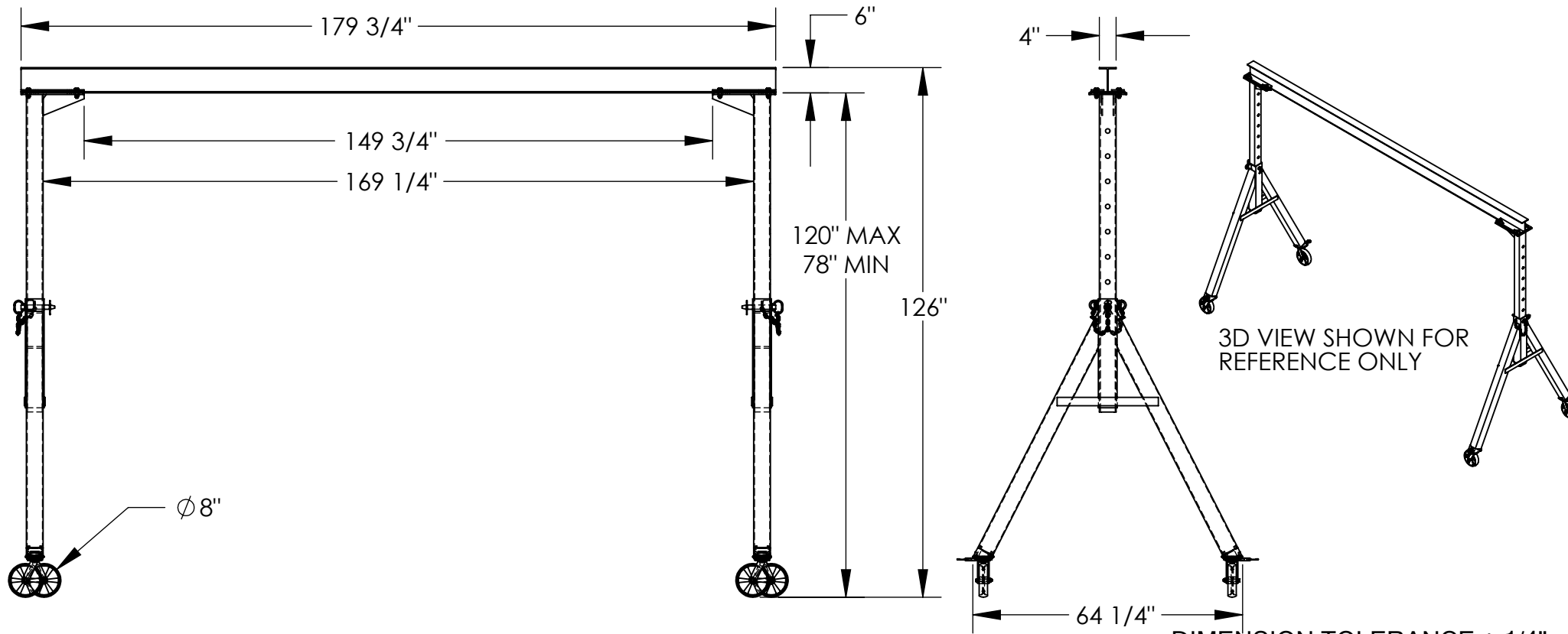

## STANDARD FEATURES

- MODEL NUMBER IS AHS-2-15-10
- CAPACITY IS 2,000 LBS.
- BASE WIDTH IS 64 1/4"
- MAX OVERALL HEIGHT IS 126"
- I-BEAM HEIGHT IS 6"
- I-BEAM FLANGE WIDTH IS 4"
- OVERALL I-BEAM LENGTH IS 179 3/4"
- USABLE I-BEAM LENGTH IS 149 3/4"
- ADJUSTABLE UNDER I-BEAM HEIGHT
  - 120" MAX
  - 78" MIN
- HEIGHT IS ADJUSTABLE IN 6" INCREMENTS
- CASTERS: (4) Ø8" X 2" WIDE GLASS FILLED NYLON SWIVEL CASTERS WITH FOUR LOCKING POSITIONS
- DURABLE LIQUID PAINT BLUE FINISH

## SPECIAL FEATURES

NONE

|   |  |                                    |
|---|--|------------------------------------|
| <b>APPROVAL</b>   | I, THE UNDERSIGNED, AGREE THAT THE PRODUCT AS REPRESENTED SATISFIES DESIGN AND DIMENSION REQUIREMENTS. I ALSO ACKNOWLEDGE MY DUTY TO CONFIRM PRODUCT AND INSTALLATION COMPLIANCE WITH ALL APPLICABLE FEDERAL, STATE AND LOCAL REGULATIONS AND STANDARDS. |                                    |
|   | <b>UNITS REQUIRING APPROVAL DRAWINGS OR MODIFIED ARE NON-RETURNABLE</b>  |                                    |
|   | <input type="checkbox"/> As drawn  | <input type="checkbox"/> As marked |
| Signed: _____   |  | Date: _____                        |
| Printed Name: _____   |  |                                    |
| <i>LEAD TIME WILL START UPON RECEIPT OF SIGNED APPROVAL DRAWING</i> |  |                                    |

|                      |             |            |
|----------------------|-------------|------------|
| DISTRIBUTOR'S NAME:  |             | P.O.#      |
| VESTIL MANUFACTURING |             | X          |
| DRAWN BY: ND         |             | W.O.#      |
| DATE: 10/12/2009     |             | X          |
| REFERENCE: X         | SCALE: 1:35 | SALES: X   |
| QUOTED LEAD TIME: X  | QUOTE # X   | FILE NAME: |
|                      |             | 28-007-202 |