

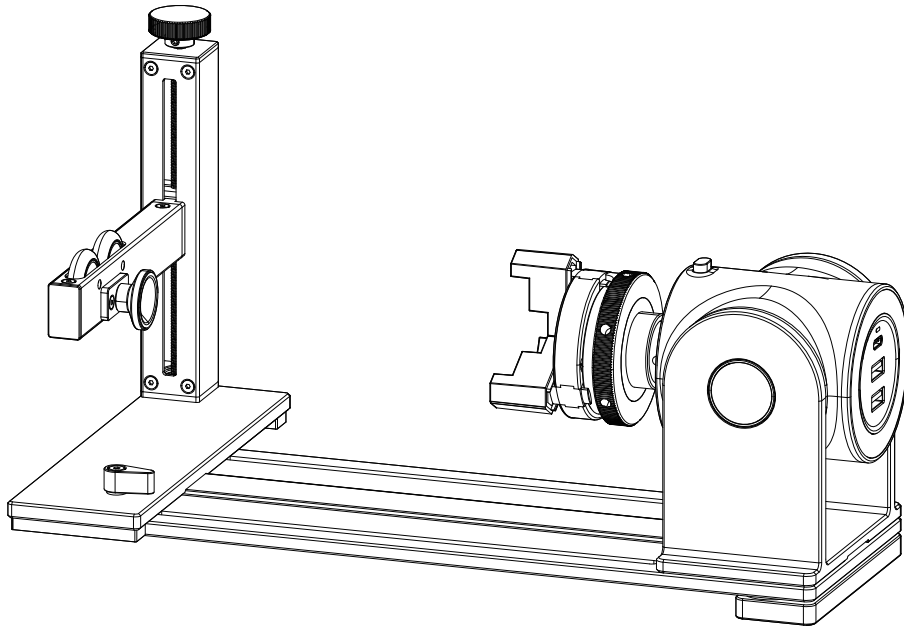

# **LX1 & LX1 Max**

## Rotary Extension User Manual



**此页不印刷内容**

## After-Sales Services

- Technical support for this product is available globally. Please contact us if you encounter any problem with your LX1 & LX1 Max and we will get back to you as soon as possible.
- Email: [support@laserpecker.com](mailto:support@laserpecker.com)

## Online User Community

- LaserPecker's huge online global community connects our diverse group of dedicated users and offers support, inspiration, and a showcase for sharing creativity.
- Facebook: LX1 Series VIP Group



LX1 Series VIP Group

## List of Included Parts

Double-step  
Jaw \* 3

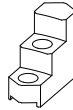

Single-step  
Jaw \* 3

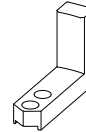

Stud  
Component \* 3



Rotary Head\*1

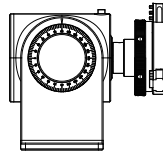

Base Plate\*1



1m USB-A Cable \*1



Tailstock\*1

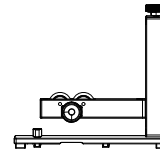

Elevation Pad \* 1

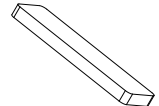

M3x6 Screw \*6



M3x10 Screw \*4



Hex Key\*1



# Component Overview & Descriptions

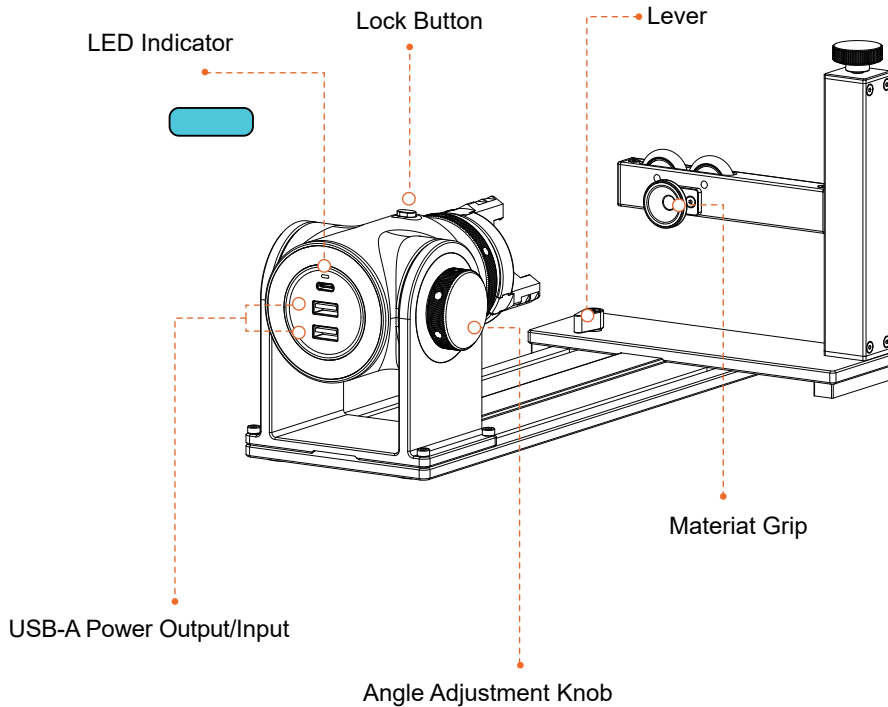

# Component Overview & Descriptions

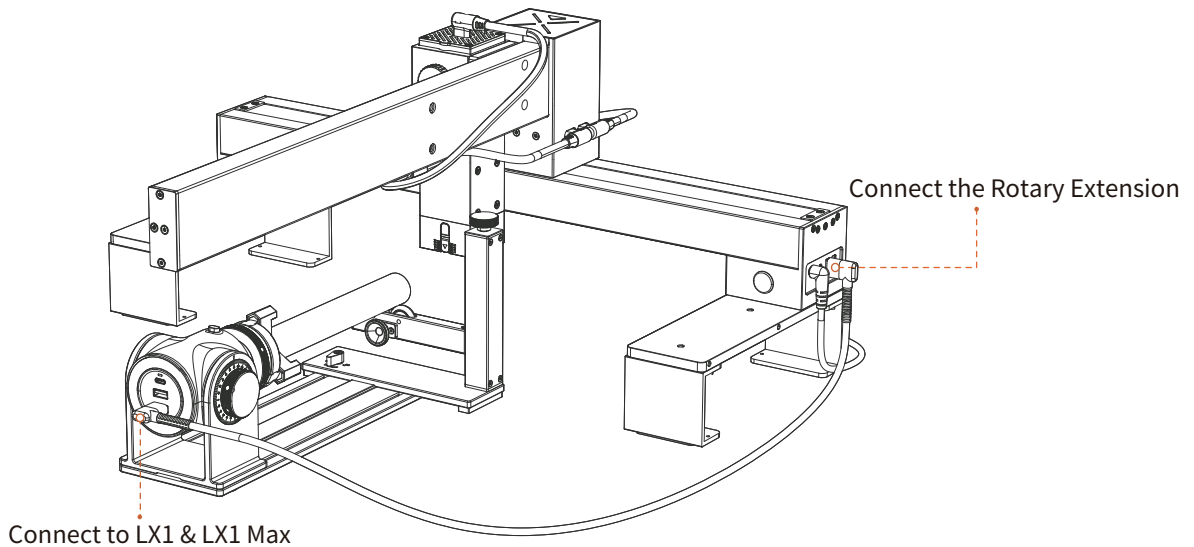

# Quick Installation

## 1 Assemble the Riser Add-on(sold separately)

Tighten the screws to connect the heightening feet to the LX1 & LX1 Max support feet

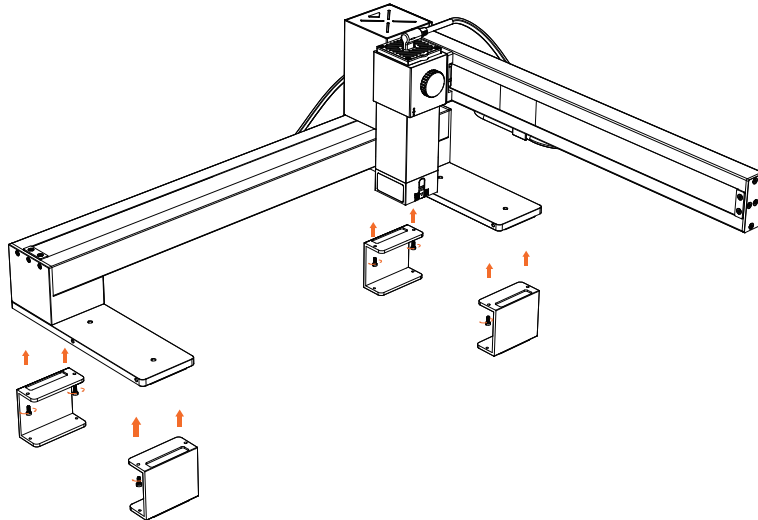

## 2 Assemble the Rotary Headstock

Attach Rotary Head to Base Plate with 4 pcs of M3x10 screws and the Hex Key.

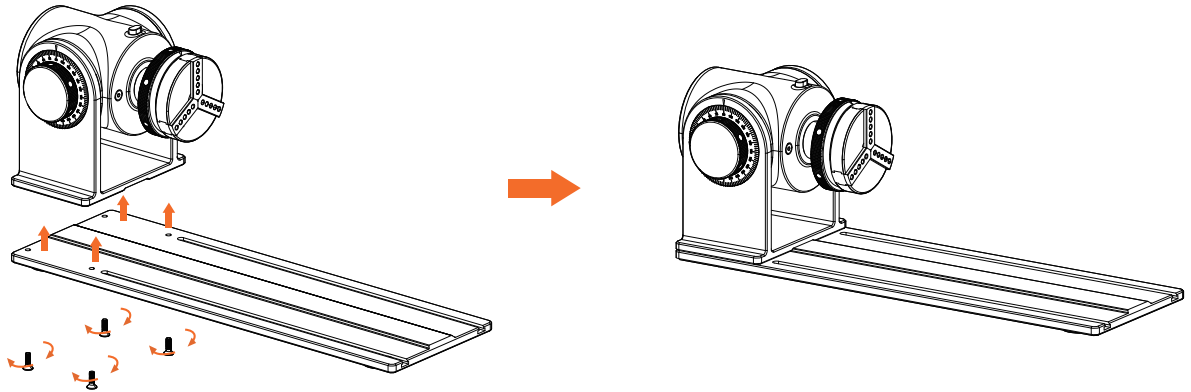

### 3 Headstock Assembly

#### ① Double-step Jaws Installation

Attach three double-step jaws to the rotary chuck using the wrench and 6 pcs of M3x6 screws.

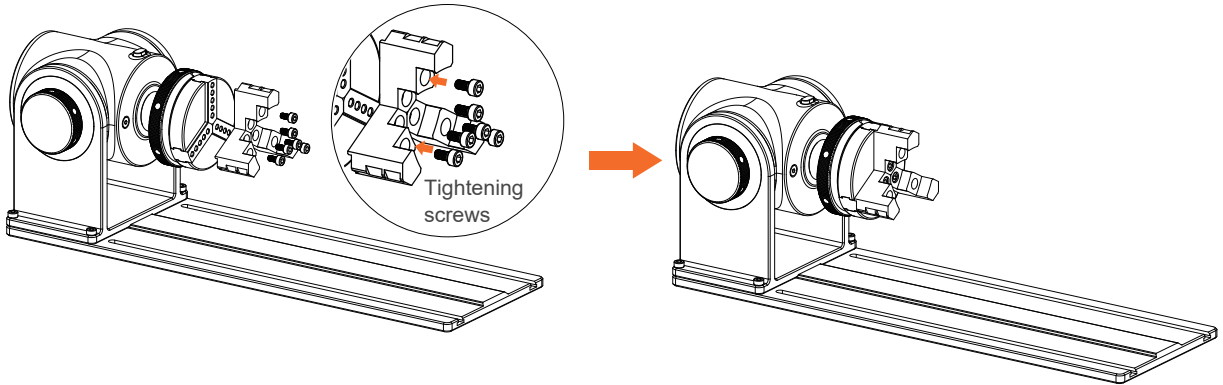



## ② Single-step Jaws Installation

Attach three single-step jaws to the rotary chuck using the wrench and 6 pcs of M3x6 screws.

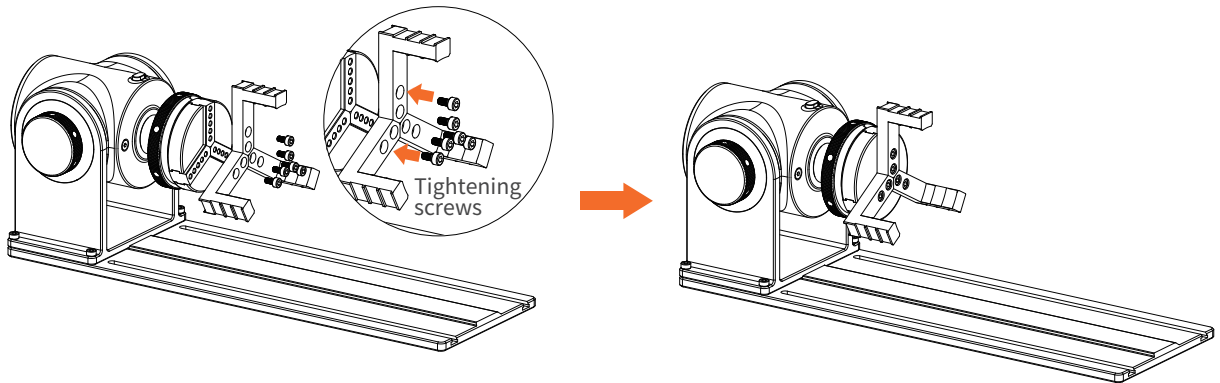

### ③ Stud Component Installation

Attach three stud components to the rotary chuck.

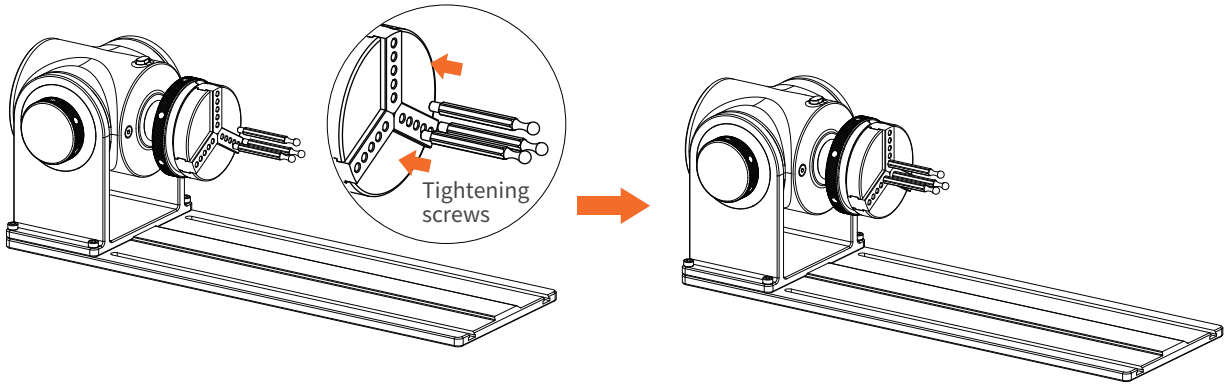

## 4 Rotary Extension Assembly

Slide the Tailstock onto the track along the base of the Rotary Head

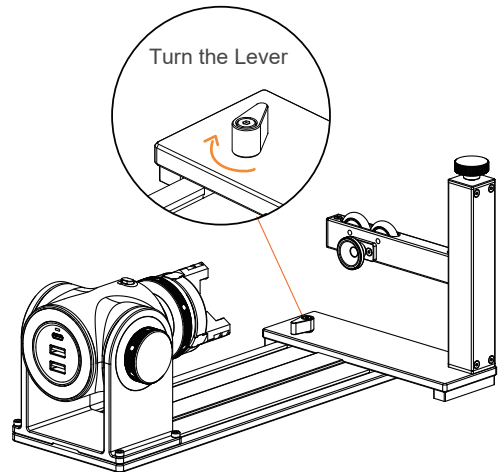
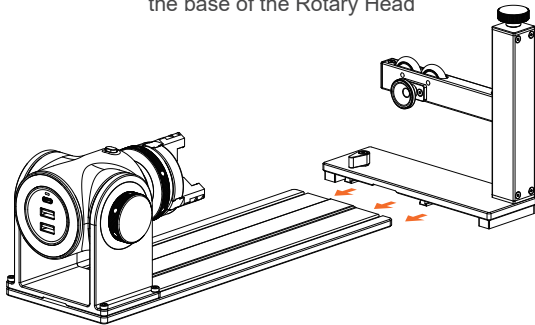

## Quick Start Guide

Turn on Mode Settings>Rotary Extension on the app, and the LX1 & LX1 Max laser module will automatically move to the specified position. According to the position of the laser head, adjust the position of the rotary extension, and perform manual focus at the same time. Open the preview to align the objects that need to be sculpted.

- 1 Turn on the Rotary Extension button.
- 2 Turn the screw at the top of the Tailstock to adjust the height of the support bracket.

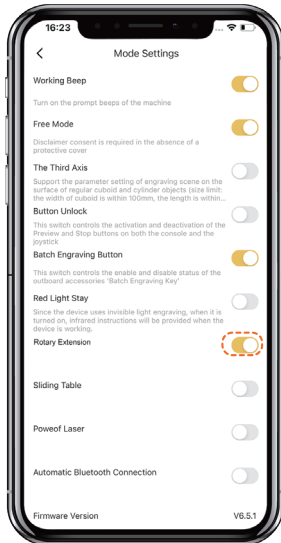

Turn the knob

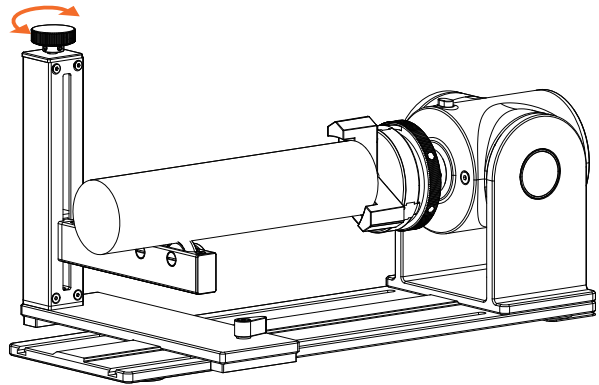

- 3 When the object is too large, press down the Lock Button and turn the gear on the chuck till the jaws can hold the object.

- 4 When the object is fixed, press up the Lock Button so the chuck will rotate as it should when previewing and engraving/cutting.

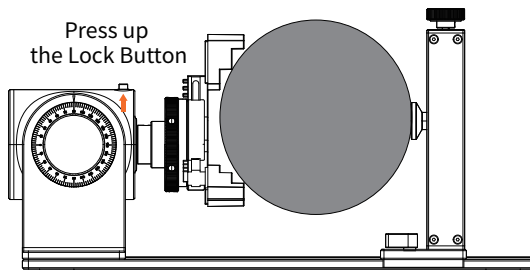
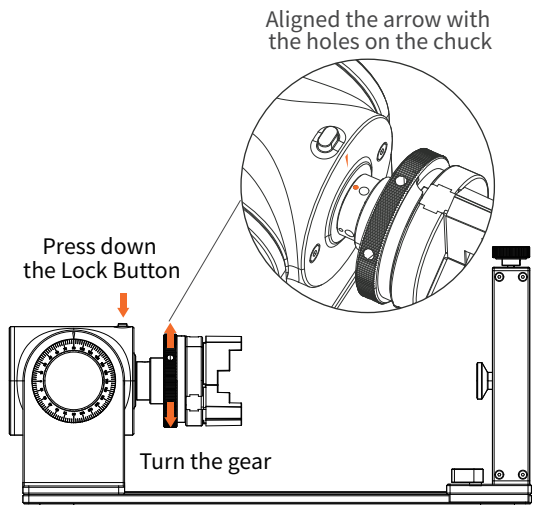

# Product Specification

Size	308*108*99mm
Weight	1.7kg
Chuck diameter range	52mm-80mm
Engraving maximum diameter	200mm
Appearance	Anodic oxidation of aluminum alloy
Engraving diameter range (Double-step Jaw)	0mm-128mm
Engraving diameter range (Single -step Jaw)	66mm-145mm
Engraving diameter range (Stud Component)	13mm- 78mm
Operating system	Support iOS 9.0+, Android 6.0+, MacOS 10+, Windows 10+
Power input	5V/1A
Precise control	0.014°
Idling movement speed	140.625 degrees/second
Fastest engraving speed	$V = 360/200/128/0.00012 = 117.1875$ degrees per second
Slowest engraving speed	$V = 360/200/128/0.00012 = 117.1875$ degrees per second

**此页不印刷内容**

# LaserPecker

---

Shenzhen Hingin Technology Co., Ltd

We support global online technical support services for this product. If you have any problems during your use, please contact us.

Email: [support@laserpecker.com](mailto:support@laserpecker.com)