

USER MANUAL

CREEPER ICE dry ice machine

V1.1
2021/10/25



CREEPER ICE PLUS



CREEPER ICE

Showven Technologies Co., Ltd

USER MANUAL

CREEPER ICE dry ice machine

★Please read this manual carefully before operating this product.

★Warranty card attached in the manual, please keep it well.

▲SAFETY CONSIDERATIONS

- \ Unauthorized repair are prohibited, it may cause serious incident
- \ Never store dry ice in sealed container, it may explosion due to dry ice sublimates to carbon dioxide gas.
- \ Never cover or block the nozzle when operation to avoid explosion due to the generation of carbon dioxide gas.
- \ Wear thick gloves when handling dry ice, do NOT handle with bare hands.
- \ Do NOT swallow dry ice, it may lead to severe injuries.
- \ Before breaking the dry ice, cover it with a piece of cloth or place it in a cloth bag, do wear protective goggles.
- \ Dry ice gives off carbon dioxide gas, which may cause difficulty breathing or suffocation. So please make sure the space is well ventilated before operate CREEPER ICE machine, do NOT use in confined space.
- \ Make sure power supply in consistent with the rated voltage of the equipment, and the socket must well grounded. Unplug and turn off the machine when not use.
- \ The output nozzle is very hot when machine is running, do NOT touch it. Keep a minimum distance of 2m from the nozzle to nearest object.
- \ Do NOT use the product as a space heater.
- \ Always disconnect the power connection before cleaning.
- \ Empty the water tank before transport or storage the machine.
- \ For safety reasons, please operate the product on horizontal ground only. Lock wheels to keep from moving.
- \ Use clean water as impurities may result in damage to the machine.
- \ Do not operate product in ambient temperature higher than 50°C.
- \ Always install the machine in well ventilated place, at least 50cm space around the machine. Do NOT cover the nozzle.
- \ For adult use only, keep it away from children, fire, inflammable and explosive articles.
- \ The area in front of machine may become wet during operation. Be aware of the slip ground.
- \ If the machine fails to work, please stop operation and unplug the machine. Check fuse, power cable and socket etc. carefully, if can't solve the problem, please contact SHOWVEN (info@showven.cn) or your local SHOWVEN partner for advise.

▲Foreword

Thanks for choosing SHOWVEN CREEPER ICE series dry ice machine. Please read following manual carefully and completely before operating this product. Operate according to instructions is very important for safety, and can elongate the service life of the machine.

▲Functional Characteristics

- \ Molded enclosure, lighter, durable and rustless.
- \ Water spray design, fast ON/OFF, dry ice saving
- \ No mechanical lifting structure, better stability
- \ Huge ice and water reservoir, supporting long effects time
- \ Continuous variable fog output adjustment, meet different application scenario
- \ Water tank and ice basket separate design, longer ice storage time, achieve multi use with single ice feeding
- \ Dual or triple heating system, flexible power switch meet different power supply
- \ Abrasion-resistant silent caster
- \ Easier residual water drainage
- \ Rain-proof structure

▲Technical Specifications

\ Model:	CREEPER ICE PLUS	CREEPER ICE
\ Dimension:	642x584x887mm	492x584x760mm
\ Packing Dimension:	677x619x826mm	527x619x726mm
\ Voltage:	AC220-240V, 50/60Hz AC100-120V, 50/60Hz	AC220-240V, 50/60Hz AC100-120V, 50/60Hz
\ Fuse:	Breaker 3P 20A	Breaker 20A
\ Work power:	3000W/9000W (230V) 1600W/4800W (120V)	3000W/6000W (230V) 1600W/3200W (120V)
\ Heating Up Time:	Appr. 40min @9000W Appr. 70min @4800W	Appr. 30min @6000W Appr. 50min @3200W
\ Dry Ice Capacity:	30kg	15kg
\ Water Tank Capacity:	75L	55L
\ DMX-512:	yes	yes
\ Wireless Control:	yes	yes
\ Output Volume Adjustment:	50%-100%	50%-100%
\ Max. Coverage Area:	Appr. 800 m ²	Appr. 500 m ²
\ Cumulative Output Time:	5-10min	5-10min
\ Consumable:	Dry ice, Water	Dry ice, Water
\ Net. Weight:	45kg	35kg
\ Gross Weight:	68kg	50kg

▲Product Overview

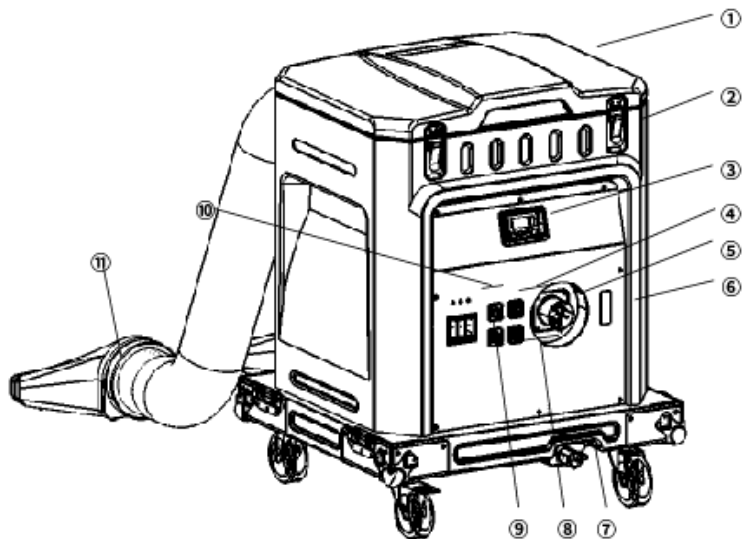

CREEPER ICE PLUS

1. Upper Cover
2. Upper Cover Lock
3. LCD and Function Buttons
4. 3-pin XLR
5. Industrial Power Socket
6. Water Level Indicator
7. Drain Valve
8. 5-pin XLR
9. Air Switch
10. LED Indicator x3
11. Fog Outlet

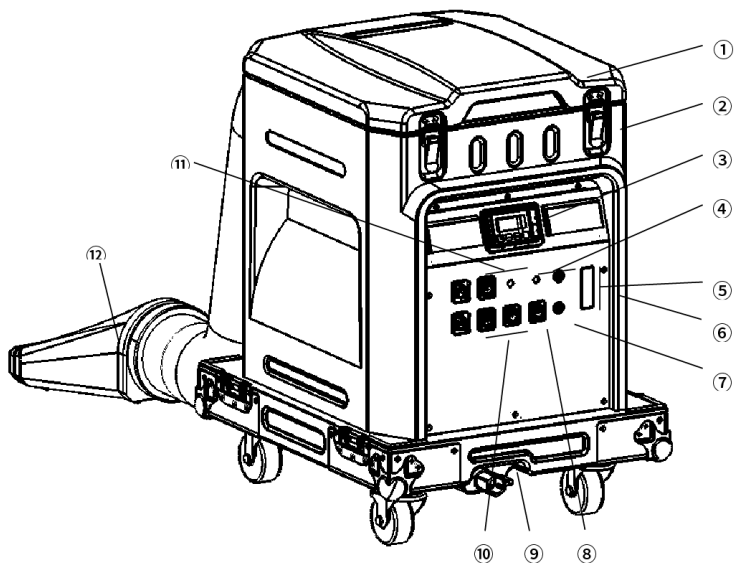

CREEPER ICE

1. Upper Cover
2. Upper Cover Lock
3. LCD and Function Buttons
4. LED Indicator x2
5. Fuse x2
6. Water Level Indicator
7. Auxiliary Power Input
8. Main Power Input
9. Drain
10. 5-pin XLR
11. 3-pin XLR
12. Fog Outlet

▲Operation Panel

1. Control button area

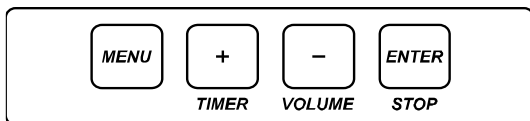

MENU: switch through setup menu;

+: parameter up, multiplex "TIMER" (Timer Fog output when in main interface);

-: parameter down, multiplex "VOLUME" (Continuous Fog output when in main interface);

ENTER: confirm and save parameters (screen will blink once when save successfully); multiplex "STOP".

NOTE: Screen will switch to main interface automatically if not press any button in 15s.

▲Interface

1. Main interface:

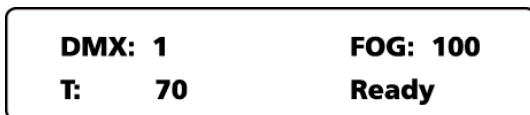

First Line: DMX address and Fog Output Volume, ":" blinks when there is DMX in signal.

Second Line: water temperature, when temp. reached set temp. it will show "READY" means the machine is ready to firing, press "VOLUME" to generate fog.

2. Error Information:

Error information	Explanation
E1 No Water	Filling the water tank
E2 Temp. Sensor	Temp. Sensor loose or sensor cutting out
E5 K Temp. Over	Circuit board malfunction
E6 Heat Fail	Heater broken or circuit board malfunction.

3. Setting Menu

Press "MENU" switch through setup menu.

Items	Value	Explanation
DMX Address	1~511	DMX address setup
Temp. Setup	60-80°	Water TEMP. Set, the higher the temp. the longer the fog output
Fog Volume Output	50-100%	Fog output volume increase as the value increase
Wireless Set	ON / OFF	Wireless function set
Language	中文/English	Language switch

▲Operation

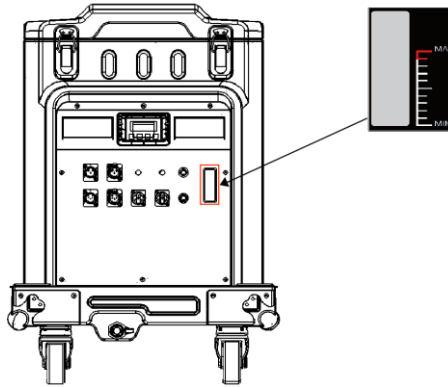

1. Check the machine and accessories, ensure it is in good status. Place the machine on a flat surface, tilting may result in inaccurate water level alarm. Lock wheels to keep from moving.
2. Open the upper cover and filling the machine with water until reached the Max. water level. CREEPER ICE water tank is 55L, CREEPER ICE PLUS is 75L.
3. Connect the machine to suitable rated power supply. Please ensure power supply meets the requirement. Always connect the machine to a protected circuit and ensure it is properly grounded.
4. CREEPER ICE with dual power supply design, users can use single or dual power to heating up. Whenever in single or dual power mode, the main power input must connected, the corresponding LED indicator will light up when power supply connected successfully.
5. CREEPER ICE PLUS use industrial power socket. Turn on the air switch when power connected, and the LED indicator will light up.
6. Open the upper cover, put the dry ice into basket. Close the upper cover and lock it. If filling the ice basket outside of machine, please make sure it well fitted when put it back to machine.
7. When machine was ready, water reached set temp., press VOLUME the machine will start to work. When water temp. lower than 30°, machine will stop working automatically, operator can also press STOP to stop the machine.
8. If need to transport the machine after show, please drain the remaining water when it is cool down. Please be aware of the hot water.

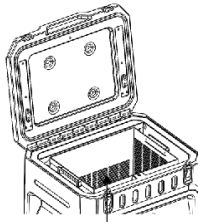

Ice basket

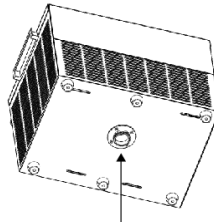

Ice basket
connector part

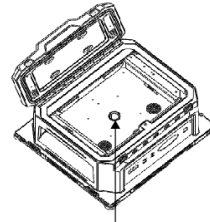

Machine connector
part with ice basket

▲DMX Control

channel	Function
CH1	1~5: Fog off 6~255: Fog volume adjustment, fog volume increase from 50% to 100%

▲Wireless Control

Wireless control is used to remote control the machine. Before use the wireless function please make sure machine was ready, wireless status was ON, and no DMX cable connection.

Remote controller:

- A. Fog output START
- B. Fog output STOP

If the wireless remote is not working, please check the wireless function setup on machine. Press "MENU" find "wireless control" switch it into "ON", press "ENTER" to save the setup. Remote control match with machine was also in this interface, press any key on remote control for 1s, the LCD screen will blink once, means the match was successful.

NOTE: Remote controller is optional configuration. You can buy it separately from SHOWVEN or SHOWVEN authorized partners.

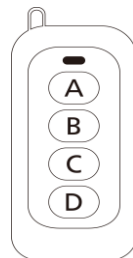

▲Product Package

CREEPER ICE

- Main unit x 1unit
- Power Cable x 2 pieces
- User Manual x 1 piece
- Fog vent hose 3.3m x 1piece
- Flight case package



CREEPER ICE PLUS

- Main unit x 1unit
- Power Cable x 1 pieces
- User Manual x 1 piece
- Fog vent hose 3.3m x 2 pieces
- Fog vent head x 2 pieces
- Flight case package



▲Caster Installation

Please install the caster according to below schematic diagram. The brake wheel must installed in specific position accordingly.

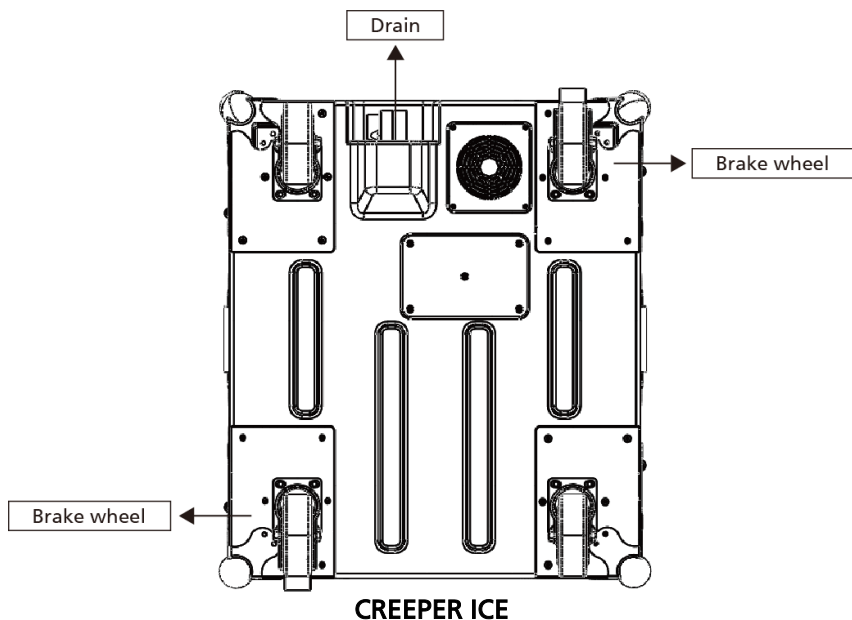
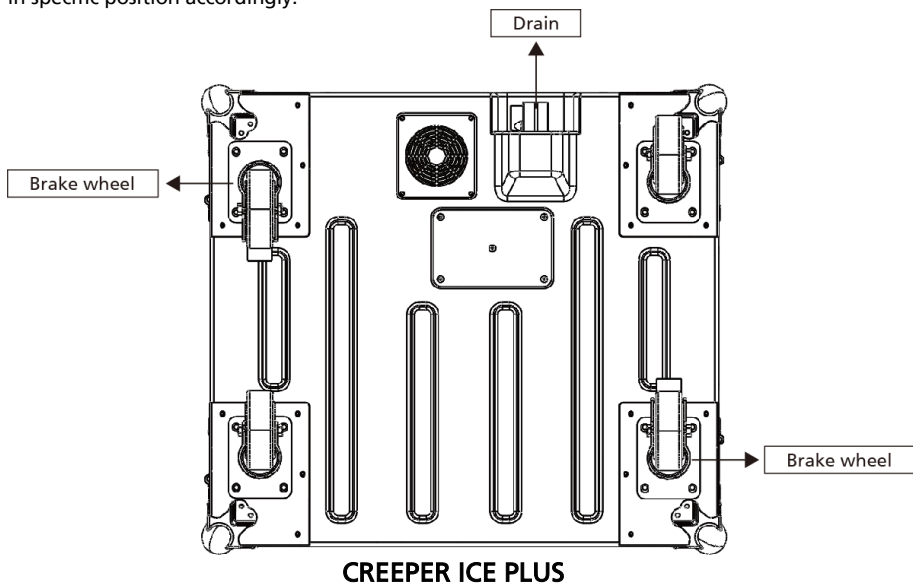

Warranty Instructions

▲ Sincere thanks for your choosing our products, you will receive quality service from us

▲ The product warranty period is one year. If there are any quality problems within 7 days after shipping out from our factory, we can exchange a brand new same model machine for you

▲ We will offer free of charge maintenance service for machines which with hardware malfunction (except for the instrument damage caused by human factors) in warranty period. Please don't repair machine without factory permission

★Below situations NOT included in warranty service:

1. Damage caused by improper transportation, usage, management, and maintenance, or damage caused by human factors;
2. Disassemble, modify or repair products without permission;
3. Damage caused by external reasons (lightning strike, power supply etc.)
4. Damage caused by improper installation or use;

For product damage not included in warranty range, we can provide paid service.

★Invoice and warranty card are necessary when applying for maintenance service from SHOWVEN.

Warranty Card

Product Name:		Serial No.	
Purchase Date:			
Tel:			
Address:			
Info. feedback about the problem:			
Actual problem:			
Maintenance detail:			
Service Engineer:		Service Date:	

SHOWVEN[®]



Showven Technologies Co., Ltd.

Tel: +86-731-83833068

Web: www.showven.cn E-mail: info@showven.cn

Add: Liuyang Economic Development Zone, Changsha, 410300, Hunan Province,
P.R.China