

UNIT – VI: REPRODUCTION

CHAPTER-1

SEXUAL REPRODUCTION IN FLOWERING PLANTS

Topic-1

Sexual Reproduction in Flowering Plants

Concepts Covered • Structure of a flower, male and female reproductive structures, development of male and female gametophytes.



Revision Notes

- ▶ **Flower**
 - Flowers are the site of sexual reproduction in flowering plants.
 - Parts of a typical angiospermic flower are: sepals, petals, stamens and pistils.
 - The four whorls of the flower are attached on a central axis called thalamus.
 - A flower can be bisexual (contains both male and female reproductive parts) or unisexual (only one of the reproductive parts is present).
- ▶ **Male Reproductive Structures**
 - Androecium (Whorl of Stamens)**
 - Androecium consists of a whorl of stamens.
 - The number and length of the stamens are variable in flowers of different species.
 - A stamen has three parts namely, anther, filament and connective.
 - (a) Anther**
 - It is the terminal and bilobed part of stamens attached with filament. A bilobed anther is called dithecous.
 - Each lobe has two pollen sacs or microsporangia. Therefore, the anther is tetrasporangiate.
 - A longitudinal groove runs lengthwise separating the theca.
 - (b) Filament**
 - It is the long and slender stalk part of the stamen.
 - Its proximal end is attached to the thalamus or petals of the flower.
 - (c) Connective**
 - The structure which connects the anther lobes is known as connective.
- ▶ **Transverse section of an anther**
 - The anther is tetragonal in a structure consisting of four microsporangia or pollen sacs located at the corners, two in each lobe.
 - The microsporangia develop to become pollen sacs.
 - They extend longitudinally throughout the length of an anther.
 - These are packed with pollen grains.
- ▶ **Structure of microsporangium or pollen sac**
 - It is circular and is generally surrounded by wall layers namely,
 - (a) Epidermis (b) Endothecium
 - (c) Middle layers (d) Tapetum
 - The first two layers perform the function of protection and help in **dehiscence** of anther to release the pollens.
 - The middle layers and the innermost layer, (tapetum) nourishes the developing pollen grains.
 - The cells of the tapetum possess dense cytoplasm and more than one nuclei.
 - When the anther is young, a group of compactly arranged **homogenous** cells called sporogenous tissues occupies the centre of each microsporangium.



Key Words

Homogenous: Common origin or environment.

Viability: Ability to survive.

Dehiscence: Splitting or bursting

► **Microsporogenesis**

- When the anther develops, each cell of sporogenous tissue undergoes meiotic division to form microspore tetrads.
- Each cell of sporogenous tissue is a microspore mother cell (MMC) or pollen mother cell (PMC).
- The process of formation of microspores from a pollen mother cell (PMC) through meiosis is called microsporogenesis.

► **Dehiscence of anther**

- The microspores get arranged in a group of four cells and each group is called microspore tetrad.
- As the anthers mature and dehydrate, the microspores dissociate from each other and develop into pollen grains.
- From each microsporangium, thousands of pollen grains are formed and released due to the **dehiscence** of anther.

► **Pollen grain (Male gametophyte)**

- Pollen grain germinate and give rise to male gametophyte.
- These are spherical, measuring about 25-50 micrometers in diameter.
- Pollen grains are well preserved as fossils due to the presence of sporopollenin, a tough, resistant and stable material.
- A pollen grain has a two-layered wall namely, exine and intine.

(a) **Exine**

- Exine is the hard outer layer which is made up of sporopollenin.
- The sporopollenin is one of the most resistant organic materials.
- It can withstand high temperature and strong acids and alkali.
- It cannot be degraded by enzymes.
- The exine has apertures called germ pores where sporopollenin is absent.

(b) **Intine**

- It is the inner, thin and continuous layer that is made up of cellulose and pectin.
- A mature pollen grain contains two cells namely, vegetative cell and generative cell.

(i) **Vegetative cell**

- It is the bigger cell having abundant food reserve and a large irregularly shaped nucleus.

(ii) **Generative cell**

- It is the smaller cell that floats in the cytoplasm of the vegetative cell.
- It is spindle shaped with dense cytoplasm and a nucleus.
- The pollen grains are generally shed at the 2-celled stage in flowering plants.
- In other plants, the generative cell divides mitotically to give rise to the two male gametes before pollen grains are shed in a 3-celled stage.
- Once they are shed, pollen grains have to land on the stigma before they lose **viability**.
- The period of pollen grains remaining viable varies and depends on the prevailing temperature and humidity.
- The viability of pollen grains of some cereals such as rice, wheat, etc. is 30 minutes while some members of Leguminosae, Rosaceae & Solanaceae have viability for months.
- Pollen grains of some plants like *Parthenium* are allergic for some people leading to chronic respiratory disorders such as asthma, **bronchitis**, etc.
- Pollen grains are rich in nutrients.
- Pollen tablets are used as food supplements.
- Pollen consumption in the form of tablets and syrups increases the performance of athletes and race horses.
- It is possible to store pollen grains for years in liquid nitrogen (-196°C).
- The pollens stored in the pollen banks for **crop breeding** programmes.



Key Words

Bronchitis: Inflammation of the mucous membrane in the bronchial tubes.

Crop breeding: Deals with the production and selection of superior phenotypes for the development of improved and new varieties.

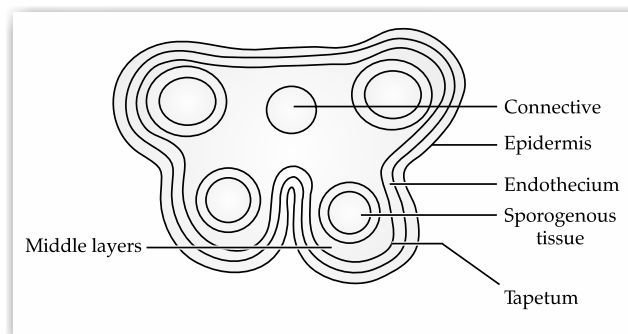

Fig 1.1: Transverse Section of a young anther



Mnemonics

Concept: Male Reproductive Structures

Mnemonic: Ask For Connectivity

Interpretation: Anther, Filament, Connective

Concept: Structures of microsporangium or pollen sac

Mnemonic: Eating Tomato

Interpretation: Endothecium, Tapetum

Concept: Female Reproductive Structures

Mnemonic: Small Soft Ornament

Interpretation: Stigma, Style, Ovary

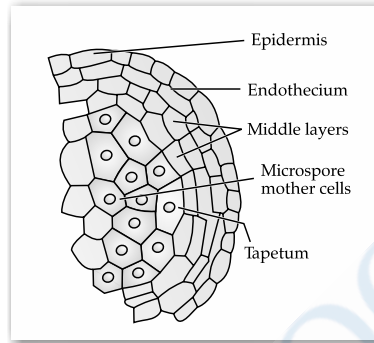

Fig 1.2: Enlarged view of an microsporangium

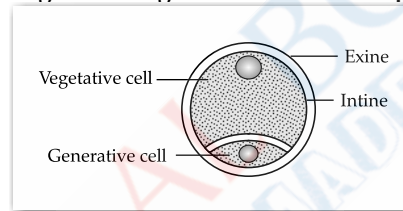

Fig 1.3: Structure of two-celled male gametophyte (pollen grain)

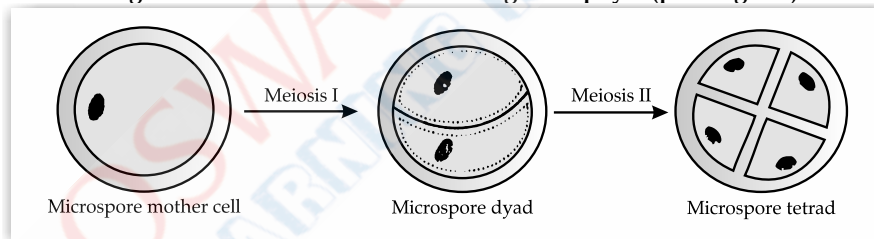

Fig 1.4: Microsporogenesis

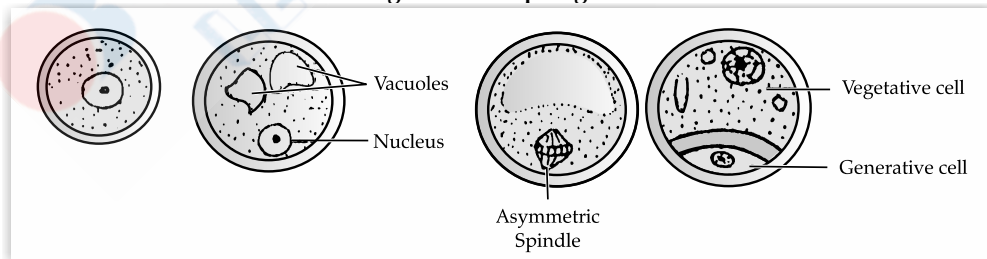

Fig 1.5: Stages of a microspore maturing into a pollen grain

► Female Reproductive Structures

Gynoecium (Pistil)

- It represents the female reproductive part of the flower.
- If it consists of a single pistil or carpel then, it is known as monocarpellary or if it has more than one pistil or carpel then, it is called multicarpellary.
- When there is more than one carpel, they may be fused then the pistil is known as syncarpous or may be free then, it is known as apocarpous.
- Each carpel has three parts namely stigma, style and ovary.

(a) Stigma

It is a landing platform for pollen grains.



Key Words

Placenta: The surface of the carpel to which the ovules are attached.

Integuments: Outer hard protective layer in plants.

Degenerate: To lose structural or physical ability.

(b) Style

It is an elongated slender part beneath the stigma.

(c) Ovary

- It is the basal swollen part of the carpel.
- Inside the ovary is the ovarian cavity called the locule where the **placenta** is located.
- **Placenta** contains the ovules or megasporangia.
- The number of ovules in an ovary may be one as seen in wheat, paddy, mango, etc., or many as seen in papaya, watermelon, orchids, etc.

➤ Megasporangium (Ovule)

- It is a small structure attached to the placenta by a stalk called the funicle.
- The junction where the body of the ovule and funicle fuse is called the hilum.
- Each ovule has one or two and some times three protective coverings called **integuments**.
- **Integuments** encircle the ovule except at the tip where a small opening called micropyle is organised.
- Opposite to the micropylar end is the chalaza which is the basal part of the ovule.
- Within the integuments, there is a mass of cells called nucellus which contains reserve food materials.
- Inside the nucellus there is an embryo sac, which is also called as the female gametophyte.
- An ovule has a single embryo sac usually formed from a single haploid megaspore.

➤ Megasporogenesis

- The formation of haploid megaspores from the diploid megaspore mother cell (MMC) as a result of meiosis is called megasporogenesis.
- A single megaspore mother cell is differentiated in the micropylar region of the nucellus.
- The megaspore mother cell is a large cell containing dense cytoplasm and a prominent nucleus.
- The megaspore mother cell undergoes meiotic division resulting in the production of four haploid megaspores.

➤ Female gametophyte (Embryo sac)

- In most of the flowering plants, only one megaspore is functional while the other three **degenerate**.
- The functional megaspore develops into the female gametophyte or embryo sac.
- This method of embryo sac formation from a single megaspore is termed as monosporic development.

➤ Development of Female gametophyte

- The nucleus of the functional megaspore divides mitotically to form two nuclei which move towards the opposite poles, forming a two-nucleated embryo sac.
- Two more sequential mitotic nuclear divisions result in the formation of the four-nucleated and later the eight-nucleated stages of the embryo sac.
- These divisions are strictly free nuclear, i.e., nuclear divisions are not followed immediately by cell wall formation.
- After eight-nucleate stage, the organisation of the typical female gametophyte or embryo sac takes place.
- Generally six of the eight nuclei are surrounded by cell walls and organised into cells.
- The remaining two nuclei called the polar nuclei are found below the egg apparatus in the large central cell.

➤ Distribution of the cells within the embryo sac

- The three cells consisting of two synergids and one egg cell which are grouped at the micropylar end constitute the egg apparatus.
- The synergids have special cellular thickenings at the micropylar tip called filiform apparatus.
- The filiform apparatus helps to guide the pollen tubes into the synergid.
- Three cells at the chalazal end organise as the antipodals.
- Thus, a typical mature angiosperm embryo sac at maturity is eight-nucleate and seven-celled.

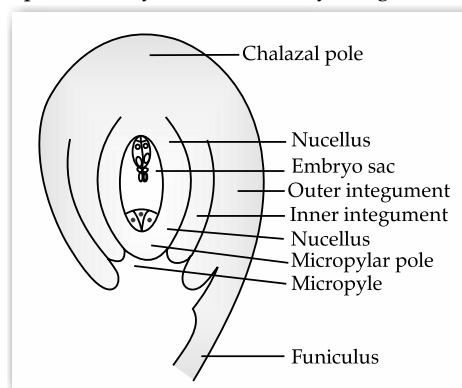

Fig 1.6: A diagrammatic view of a typical anatropous ovule

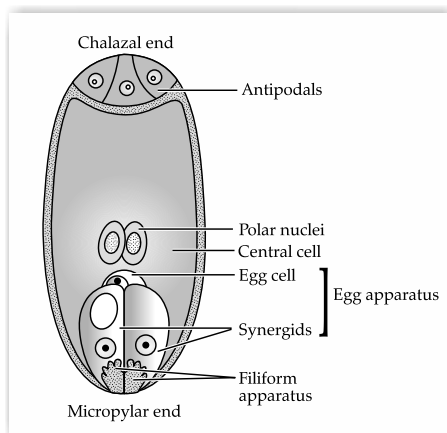

Fig 1.7: A diagrammatic view of the mature embryo

Topic-2

Pollination and Fertilisation

Concepts Covered • Modes of Pollination, • Pollen-Pistil Interaction, Artificial Hybridisation, Double Fertilisation



Revision Notes

► Modes of Pollination

- The process of transfer of pollen grains from the anther to the stigma of a pistil is known as pollination.
- There are few external agents which help the plants for pollination to take place.
- Pollination is of three types based on the source of pollens namely,
 - (a) Autogamy
 - (b) Geitonogamy
 - (c) Xenogamy

► Autogamy

- When the pollen grains are transferred from the anther to the stigma of the same flower, it is known as autogamy.
- In flowers with exposed anthers and stigma, a complete autogamy is rare and hence the anthers and stigma should lie close to each other to enable self-pollination. Along with this there should be **synchrony** in pollen release and **stigma receptivity**.
- Plants like *Viola* (common pansy), *Oxalis* and *Commelina* produce two types of flowers namely Chasmogamous flowers and Cleistogamous flowers.

(a) Chasmogamous flowers

- They are similar to flowers of other species with exposed anthers and stigma.

(b) Cleistogamous flowers

- They do not open at all.
- Anthers and stigma lie close to each other.
- They are autogamous as there is no chance of cross-pollination.
- When anthers dehisce in the flower buds, pollen grains come in contact with the stigma for pollination.
- Cleistogamous flowers produce assured seed set even in the absence of pollinators.

► Geitonogamy

- When the pollen grains are transferred from the anther to the stigma of another flower of the same plant, it is known as geitonogamy.
- It involves pollination with the help of a pollinating agent. It is structurally cross-pollination but genetically self-pollination.
- It is genetically similar to autogamy because the pollen grains come from the same plant.

► Xenogamy

- When the pollen grains are transferred from anther to the stigma of a different plant, it is known as xenogamy. It brings about genetically different types of pollen grains to the stigma.

► Agents of pollination:

- There are two types of agents of pollination namely:

- (a) Biotic agents
- (b) Abiotic agents

► Abiotic Agents

- There are two abiotic agents namely, wind and water which help pollination to take place.

► Pollination by Wind

- The pollination taking place by the wind is called anemophily.
- Wind and water pollinated flowers are not very colourful and do not produce nectar.
- Wind pollinated flowers often have a single ovule in each ovary.
- Numerous flowers remain packed into an inflorescence.
- Example – In corn cob, the tassels are the stigma and style wave in the wind to trap pollen grains. Wind pollination is commonly seen in grasses.



Key Words

Synchrony: Fluctuation of multiple populations of different places in the same way.

Stigma receptivity: Ability of stigma to support viable anther for germination.

► Characteristics of Anemophilous flowers

- The flowers produce an enormous amount of pollen.
- The pollen grains are light and non-sticky so that they can be transported through wind currents.
- They often possess well-exposed stamens for easy dispersal of pollens into wind currents.
- They have large, feathery and sticky stigma to trap air-borne pollen grains.

► Pollination by Water

- The pollination taking place by water is called hydrophily.
- It is limited to about 30 genera, mostly monocotyledons.
- In *Vallisneria*, the female flowers reach the surface of the water by the long stalk and the male flowers or pollen grains are released on to the surface of the water. These male flowers or pollen grains are carried by water currents and reach the female flowers.
- In sea grasses, the female flowers remain submerged in water and the long, ribbon-like pollen grains are carried inside the water and reach the stigma.
- The pollen grains of most of the water-pollinated species have a mucilaginous covering to protect from wetting.
- Not all aquatic plants use hydrophily. For example, in aquatic plants like water hyacinth, water lily, etc., the flowers emerge above the level of water for entomophily or anemophily i.e., for pollination to take place by insects or wind.
- It is seen in *Vallisneria* & *Hydrilla* (freshwater), *Zostera* (marine sea-grasses), etc.

► Biotic Agents

- Some flowering plants use animals as pollinating agents like Bees, butterflies, flies, beetles, wasps, ants, moths, birds (sunbirds and hummingbirds) bats, some primates (lemurs), arboreal (tree-dwelling) rodents, reptiles (gecko lizard & garden lizard) etc.
- When the pollination takes place by insects, it is known as entomophily.
- Often flowers of animal pollinated plants are specifically adapted for a particular species of animal.
- When the animal comes in contact with the anthers and the stigma, pollen grains may get stuck to the body of the animals, which results in pollination.
- Some plants provide safe places as a floral reward to lay eggs as seen in *Amorophophallus*, the tallest flower.
- There is a very close obligatory symbiotic relationship between the species of moth (*Pronuba*) and the plant *Yucca*. They cannot complete their life cycles without each other. The moth deposits its eggs in the locule of the ovary and the flower gets pollinated by the moth. The larvae of the moth come out of the eggs as the seeds start developing.
- Many insects consume pollen or nectar without bringing about pollination. They are called pollen/nectar robbers.

► Characteristics of Entomophilous Flowers

- Flowers are large, colourful, fragrant and rich in nectar.
- When the flowers are small, they form inflorescence to make them visible.
- The flowers pollinated by flies and beetles secrete foul odours to attract these animals.
- The pollen grains are generally sticky.



Key Words

Unisexual flowers: Flower which contain only one i.e., either male or female reproductive parts in it.

Monoecious: An individual possessing both male and female reproductive organs.

► Outbreeding Devices (Devices for promoting Cross-Pollination)

- To avoid self-pollination, cross-pollination is encouraged in plants as follows:

(a) Avoiding Synchronisation

- In some species, pollen release and stigma receptivity are not synchronised.
- Either the pollen is released before the stigma becomes receptive or the stigma becomes receptive before the release of pollen i.e., the anther and stigma mature at different times. This phenomenon is called dichogamy. It prevents autogamy.

(b) Arrangement of Anther and Stigma at different Positions

- In some species, the arrangement of anther and stigma at different positions prevents autogamy.

(c) **Self-incompatibility**

- It is a genetic mechanism that prevents pollen of one flower to germinate on the stigma of the same flower on of the same plant due to the presence of similar sterile genes in pollen and stigma.

(d) **Production of Unisexual Flowers (Dicliny)**

- **Monoecious** plants such as castor and maize, where the male and the female flowers are present on the same plant prevents autogamy but not geitonogamy. On the other hand, dioecious plants like papaya, where the male and female flowers are present on different plants prevent both autogamy and geitonogamy.

► **Pollen-pistil Interaction**

- It is a dynamic process involving pollen recognition followed by promotion or inhibition of the pollen.
- This interaction takes place through the chemical components produced by them.
- If the pollen is compatible, then the pistil accepts it and promotes post-pollination events.
- The pollen grain germinates on the stigma to produce a pollen tube through one of the germ pores.
- The contents of the pollen grain move into the pollen tube.
- The pollen tube grows through the tissues of the stigma and style and reaches the ovary.
- If the pollen is incompatible, then the pistil rejects the pollen by preventing pollen germination on the stigma or the pollen tube growth in the style.
- In some plants, the pollen grains are shed at the two-celled stage, the generative cell divides and forms the two male gametes during the growth of the pollen tube on the stigma.
- In plants that shed pollen in the three-celled stage, the pollen tubes carry two male gametes from the beginning.
- The pollen tube, after reaching the ovary, enters the ovule through the micropyle chalaza/integuments and then enters one of the synergids through the filiform apparatus.
- The filiform apparatus present at the micropylar part of the synergids guides the entry of the pollen tube.
- A plant breeder can manipulate pollen-pistil interaction, even in incompatible pollinations, to get desired hybrids.

► **Artificial Hybridisation**

- It is one of the major approaches of crop improvement programme by using desired pollen grains for pollination.
- This is achieved by emasculation and bagging techniques.
- Emasculation is the removal of anthers by using forceps from the **bisexual flower** bud of female parent before the anther dehiscence.



Key Words

Bisexual flower: Flower containing both male and female reproductive organs.

Synergids: In angiospermic flowers, one of the two small cells lying near the micropyle in the embryo sac.

- The emasculated flowers are then covered with a suitable bag made up of butter paper to prevent contamination of its stigma with unwanted pollen. This is called bagging.
- When the stigma attains receptivity, the mature pollen grains collected from anthers of the male parent are dusted on the stigma. Then the flowers are rebagged and allowed to develop the fruits.
- If the female parent produces unisexual flowers, there is no need for emasculation.
- The female flower buds are bagged before the flowers open.
- When the stigma becomes receptive, pollination is carried out using the desired pollen and the flower rebagged.

► **Double Fertilisation**

- The pollen tube after entering one of the **synergids** releases its contents including the two male gametes into the cytoplasm of the synergid.
- One of the male gametes moves towards the egg cell and fuses with its nucleus by the process of syngamy to form a diploid cell called the zygote.
- The other male gamete moves towards the two polar nuclei located in the central cell and fuses with them to produce a triploid primary endosperm nucleus (PEN).
- As this involves the fusion of three haploid nuclei, it is called triple fusion.
- Since two types of fusions viz. syngamy and triple fusion take place in an embryo sac, it is called double fertilisation.
- The central cell after triple fusion becomes the primary endosperm cell (PEC) and develops into the endosperm while the zygote develops into an embryo.
- It is an event unique to flowering plants.

Topic-3**Post-fertilisation Changes and Special Modes of Reproduction**

Concepts Covered • Embryo and its Development • Structure and types of Seed • Fruit and its types • Apomixis and Polyembryony

**Revision Notes****Embryo and its Development**► **Post-fertilisation Events**

- The development of endosperm and embryo, the maturation of ovule(s) into seed(s) and ovary into fruit are post-fertilisation events.

► **Endosperm Development**

- The primary endosperm cell divides repeatedly by mitosis to form a triploid endosperm tissue.
- Endosperm cells are filled with reserve food materials that are used for the nutrition of the developing embryo.
- During the endosperm development, the primary endosperm nucleus undergoes successive mitotic nuclear divisions to give rise to free nuclei. This stage is called free-nuclear endosperm.
- Then the endosperm becomes cellular due to the cell wall formation.
- For example, the tender coconut water is a free-nuclear endosperm that is made up of thousands of nuclei and the surrounding white kernel is the cellular endosperm.

► **Embryo Development**

- The embryo develops at the micropylar end of the embryo sac where the zygote is situated.
- The zygotes divides only after the formation of a certain amount of endosperm to provide nutrition to the developing embryo.
- The development of embryo is similar in monocotyledons and dicotyledons up to the octant stage.
- The zygote gives rise to the pro-embryo and subsequently to the globular, heart-shaped and mature embryo.

► **Dicotyledonous Embryo**

- It has a central embryonal axis and two lateral cotyledons.
- The portion of the embryonal axis above the level of cotyledons is the epicotyl, which terminates into the plumule (stem tip).
- The cylindrical portion below the level of cotyledon is hypocotyl that terminates into the radicle (root tip).
- The root tip is covered with a root cap.

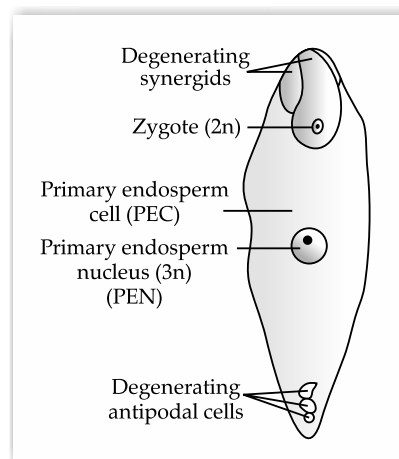

Fig 1.8: Fertilised embryo sac

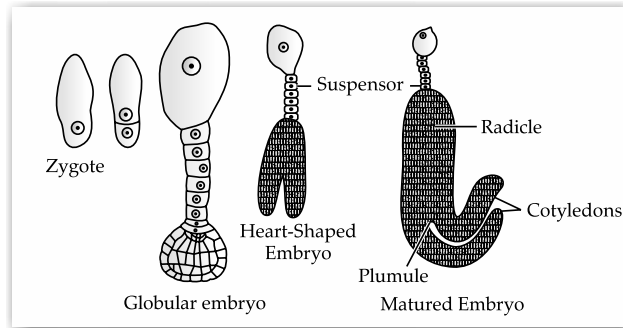

Fig. 1.9: Stages in embryo development in a dicot showing zygote and primary endosperm nucleus

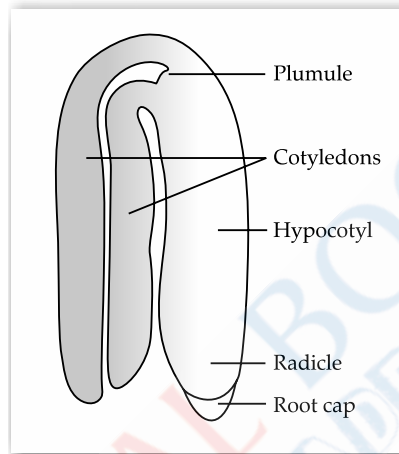

Fig 1.10: A typical dicot embryo

► **Monocotyledonous Embryo**

- They possess only one cotyledon.
- In the grass family, the cotyledon is called the scutellum which is situated lateral to the embryonal axis.
- At its lower end, the embryonal axis has the radicle and root cap enclosed in an undifferentiated sheath called coleorhiza.
- The portion of the embryonal axis above the level of attachment of the scutellum is the epicotyl.
- It has a shoot apex and a few leaf primordia enclosed in a hollow foliar structure called coleoptile.

► **Seed**

- Seed is the final product of sexual reproduction.
- It is the fertilised ovule formed inside fruits.
- It consists of the seed coat(s), cotyledon(s) and an embryonal axis.
- The cotyledons are simple, thick and swollen due to the storage of food as seen in most of the dicots.
- Mature seeds may be non-albuminous or albuminous.

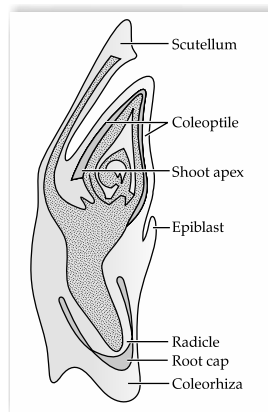

Fig 1.11: L.S of an embryo of grass

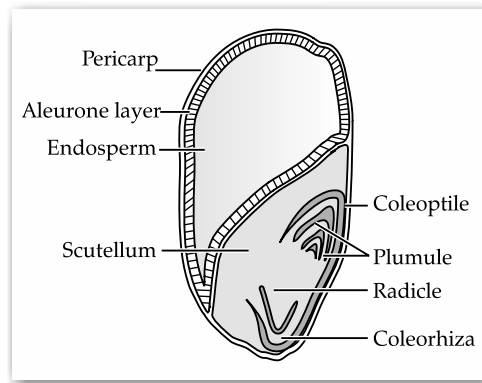

Fig 1.12: L.S (grain of maize)

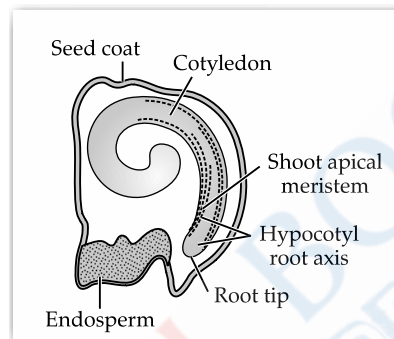

Fig 1.13: L.S. (monocot seed of onion)

► **Non-albuminous or Non-endospermic Seeds**

- These seeds have no residual endosperm as it is completely consumed during embryo development.
- Examples - pea, groundnut, beans.



Key Word

Pericarp: Part of fruit formed from the wall of the ripened ovary.

► **Albuminous or Endospermic Seeds**

- These seeds retain a part of the endosperm as it is not completely used up during embryo development.
- Examples: wheat, maize, barley, castor, coconut, sunflower.
- In some seeds like black pepper, beet, etc., the remnants of nucellus also persistent. It is called the perisperm.
- Integuments of ovules harden as tough protective seed coats.
- It has a small pore (micropyle) through which oxygen and water enter into the seed during germination.
- As the seed matures, its water content gets reduced and the seeds become dry (10-15 % moisture by mass). The general metabolic activity of the embryo slows down.
- The embryo may enter a state of inactivity (dormancy).
- If favourable conditions are available such as adequate moisture, oxygen and suitable temperature, they germinate.

► **Fruit**

- The ovary develops into a fruit after pollination and fertilisation.
- The transformation of ovules into seeds and ovary into fruit proceeds simultaneously.
- The wall of the ovary develops into a **pericarp**.
- The fruits may be fleshy as seen in guava, orange, mango, etc., or may be dry as seen in groundnut, mustard, etc.,
- Many fruits have mechanisms for the dispersal of seeds.
- Fruits are of two types namely:
 - (a) **True fruits:** When the fruit develops only from the ovary and other floral parts degenerate and fall off, they are called true fruits. Examples- mango, maize, grape.
 - (b) **False fruits:** When parts of a flower other than the ovary also contribute to the fruit formation, they are called false fruits. Examples- apple, strawberry, cashew, etc.

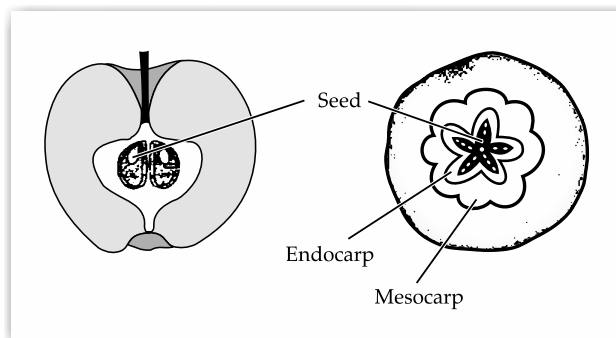

Fig 1.14: Sectional view of an apple

- In some species such as banana, the fruits develop without fertilisation, these fruits are called parthenocarpic fruits.
- Parthenocarpy can be induced through the application of **growth hormones**. Such fruits are seedless.

► Advantages of Seeds

- The pollination and fertilisation processes are independent of water while the seed formation is more dependable.
- Seeds have better adaptive strategies for dispersal to new habitats and help the species to colonise in other areas.
- They have food reserves and so young seedlings are nourished until they are capable of photosynthesis.
- The hard seed coat protects the young embryo.
- Since seeds are the products of sexual reproduction, they generate new genetic combinations leading to variations.
- The dehydration and dormancy of mature seeds are crucial for the storage of seeds.
- It can be used as food throughout the year and also to raise a crop in the next season.

► Viability of Seeds after Dispersal

- In a few species, the seeds lose viability within a few months or live for several years.
- Some seeds remain alive for hundreds of years.
- The oldest is lupine (*Lupinus arcticus*) excavated from Arctic Tundra. The seed germinated and flowered after an estimated record of 10,000 years of dormancy.
- 2000 years old viable seed is of the date palm (*Phoenix dactylifera*) discovered during the archeological excavation at King Herod's palace near the Dead Sea.

► Apomixis and Polyembryony

- Apomixis (apo = without; mixis = mixing together) means the production of seeds without fertilisation.
- It is seen in some species of Asteraceae and grasses.
- The apomixis is a form of asexual reproduction that mimics sexual reproduction.
- The occurrence of more than one embryos in a seed is called polyembryony.

► Development of Apomictic Seeds

- In some species, the diploid egg cell is formed without reduction division and develops into the embryo without fertilisation.
- In species like Citrus and Mango varieties, some of the nucellar cells surrounding the embryo sac divide and protrude into the embryo sac and develop into the embryos. Hence, in these species, each ovule contains many embryos.



Key Word

Growth hormone: Hormones which stimulate cell division, flowering, enlargement, dormancy, abscission such as Auxins, Gibberellins, cytokinins, ethylene, ABA etc.

► Importance of Apomixis in Hybrid Seed Industry

- Hybrid seeds have to be produced every year.
- If the seeds collected from hybrids are sown, the plants in the progeny will segregate and lose hybrid characters.
- The production of hybrid seeds is costly. Hence the cost of hybrid seeds is also expensive for the farmers.
- If the hybrids are made into apomictic, there is no segregation of characters in the hybrid progeny. This helps farmers to use the hybrid seeds to raise new crop year after year without losing hybrid characteristics.



Mnemonics

- 1. Concept:** Cells in Mature Embryo sac
Mnemonics: All Purpose Central Education Senior Federation
Interpretation: Antipodal, Polar nuclei, Central cell, Egg cell, Synergid, Filiform apparatus
2. Concept: L. S. of Grain of maize

Mnemonics: Personal Assistant Engineer and Senior Commandant of Railway Police Crops.
Interpretation: Pericarp, Aleurone layer, Endosperm, Scutellum, Coleoptile, Radicle, Plumule, Coleorhiza

CHAPTER-2

HUMAN REPRODUCTION

Topic-1

Human Reproductive System

Concepts Covered • Structure of Male Reproductive System, • Structure of Female Reproductive System



Revision Notes

Reproductive System

► Male Reproductive System

- It consists of :
 - (a) A pair of testes
 - (b) Accessory ducts
 - (c) Accessory glands
 - (d) External genitalia

► Testes

- Testes are the primary sex organs that produce sperms and testosterone **hormone**.
- Testes are located in the scrotum present in between upper thighs.
- The low temperature (2 – 2.5°C less than the normal internal body temperature) in the scrotum helps for the proper functioning of testes and spermatogenesis.
- Each testis is oval in shape and has about 250 (200 – 300) compartments called testicular lobules.
- Each lobule is filled with connective tissue and contains 1-3 coiled yellow seminiferous tubules in which sperm are produced.
- Seminiferous tubule is lined internally with spermatogenic cells called spermatogonia or primary male germ cells and sertoli cells or supporting cells.
- Spermatogonia undergo meiotic divisions and leads to sperm formation.
- Sertoli cells give shape and nourishment to developing spermatogenic cells and therefore also called as **nurse cells**.
- The regions outside the seminiferous tubules are the interstitial spaces which contain small blood vessels and interstitial cells or Leydig cells.
- The Leydig cells are endocrine in nature and secrete testicular hormones called androgens.
- Immunologically competent cells are also present.

► Accessory Ducts

- The duct system includes **rete testis, vasa efferentia, epididymis** and **vas deferens**.
- The seminiferous tubules open into the vasa efferentia through rete testis.
- The vasa efferentia open into the epididymis.
- The epididymis leads to vas deferens that ascends into the abdomen and loops over the urinary bladder.
- It receives a duct from the seminal vesicle and opens into the urethra as the ejaculatory duct.
- These ducts store and transport the sperms from the testis to the outside through urethra.
- The urethra originates from the urinary bladder and extends through the penis to its external opening called the urethral meatus.

► **Accessory Male Genital Glands**

- It includes paired seminal vesicles, prostate and paired bulbourethral glands (Cowper's glands).
- The secretions of these glands constitute the seminal plasma, which is rich in fructose, calcium and certain enzymes.
- Seminal vesicles produce seminal fluid and form 60 – 70% of semen.
- The secretion of bulbourethral glands is alkaline and rich in mucus. It helps in the lubrication of the penis, supplies nutrient to sperms and provides an alkaline medium to counteract the acidity of the uterus.

► **External Genitalia**

- The penis is the male external genitalia.
- It is made up of special tissue that helps in the erection of the penis to facilitate insemination.
- The enlarged end of the penis is called the glans. The penis is covered by a loose fold of skin called foreskin.

IMPORTANT DIAGRAMS

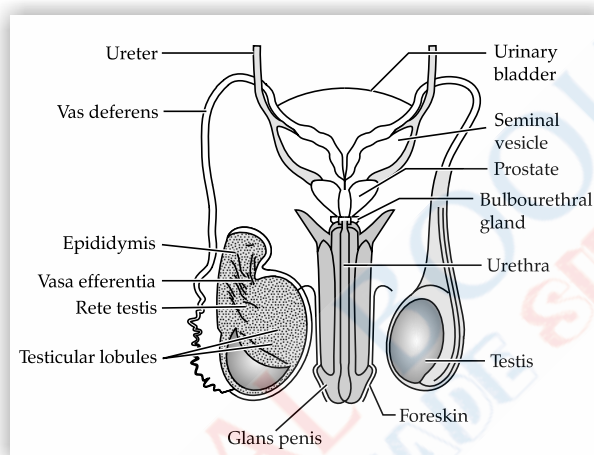

Fig 2.1 : Human Male Reproductive System

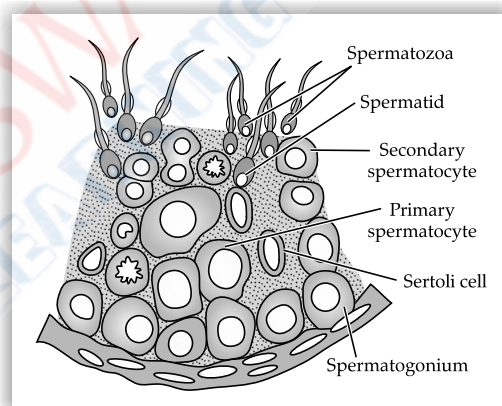

Fig 2.2 : Sectional view of human seminiferous tubule

► **The Female Reproductive System**

- It includes a pair of ovaries, accessory ducts and external genitalia.

► **Ovaries**

- They are the primary female sex organs that produce ova or the female gametes. It secretes many steroid ovarian hormones such as estrogen and progesterone.
- Ovaries are located on both sides of the lower abdomen.
- Each ovary is about 2-4 cm in length.
- The ovaries are connected to the pelvic wall and uterus by ligaments.
- Each ovary is covered by a thin epithelium which encloses the ovarian stroma.
- The stroma has outer cortex and an inner medulla.
- The ovary contains groups of cells known as Ovarian or Graafian follicles.
- Each follicle carries a centrally placed ovum.

► **Accessory Ducts**

- It includes two **oviducts** or **fallopian tubes**, **cervix**, a **uterus** and **vagina**.
- Each oviduct is 10-12 cm long and has four parts namely, infundibulum, ampulla, isthmus and uterine part.

(a) **Infundibulum**

- It is the funnel-shaped opening provided with many finger-like fimbriae for catching released ovum.
- It helps to collect the ovum after its release from the ovary.

(b) **Ampulla**

- The infundibulum leads to the curved and dilated part called the ampulla.

(c) **Isthmus**

- It is the last straight part of the oviduct.
- It has a narrow lumen and joins the uterus.

(d) **Uterine part**

- It is about 1 cm long part of the oviduct which passes into the uterus.

► **Uterus**

- It is single and also called the womb.
- The shape of the uterus is like an inverted pear.
- It is supported by ligaments attached to the pelvic wall.
- The uterus opens into the vagina through a narrow **cervix**.
- The cavity of the cervix is called the cervical canal which along with the vagina forms the birth canal.
- The wall of the uterus is thick and muscular and is differentiated into three layers of tissue namely,
 - (a) The external thin membranous perimetrium.
 - (b) The middle thick layer of smooth muscle, myometrium.
 - (c) The inner glandular layer called the endometrium.
- The endometrium undergoes cyclic changes during the menstrual cycle while the myometrium exhibits strong contraction during delivery of the baby.
- The vagina opens to the exterior between the urethra and anus.
- The lumen of the vagina is lined by a glycogen-rich mucous membrane consisting of sensitive papillae and Bartholin's glands.
- The secretions of Bartholin's glands lubricate the penis during sexual activity.

► **External Genitalia**

- It includes the **mons pubis**, **labia majora**, **labia minora**, **hymen** and **clitoris**. The external genitalia are collectively called the vulva.
- Mons pubis is a cushion of fatty tissue covered by skin and pubic hair.
- The labia majora are a pair of large thicker fleshy folds of tissue, which surround the vaginal opening.
- The labia minora are a pair of narrow fleshy folds of tissue found below labia majora.
- The opening of the vagina is often covered partially by a membrane called the **hymen**.
- The **hymen** is often torn during the first coitus (intercourse) or accidentally.
- The clitoris is a tiny finger-like structure that lies at the upper junction of the two labia minora above the urethral opening.



Key Words

Cervix : Connects vagina and uterus

Hymen : Thin membrane partially covering the vaginal aperture

► **Mammary Glands**

- A pair of mammary glands containing glandular tissue and fat is present in the chest region.
- The glandular tissue of each breast has 15-20 mammary lobes containing clusters of cells called alveoli.
- The cells of alveoli secrete milk which is stored in the cavities or lumen of alveoli.
- The alveoli open into mammary tubules.
- The tubules of each lobe join to form a mammary duct.
- Several mammary ducts join to form a wider mammary ampulla which is connected to the lactiferous duct through which milk is sucked out.



Mnemonics

1. Concept: Accessory Male Genital Glands

Mnemonics: Supreme Power in Back or Seven

Pieces of Banana

Interpretations: Seminal vesicles, Prostate,

Bulbo-urethral glands

2. Concept: Structure of Oviducts.

Mnemonics: I Am Intelligent than U

Interpretations: Infundibulum, Ampulla, Isthmus, Uterine part.

3. Concept: Female External genitalia

Mnemonics: Mobile's Light Led Him Crazy.

Interpretations: Mons pubis, Labia majora, Labia minora, Hymen Clitoris.

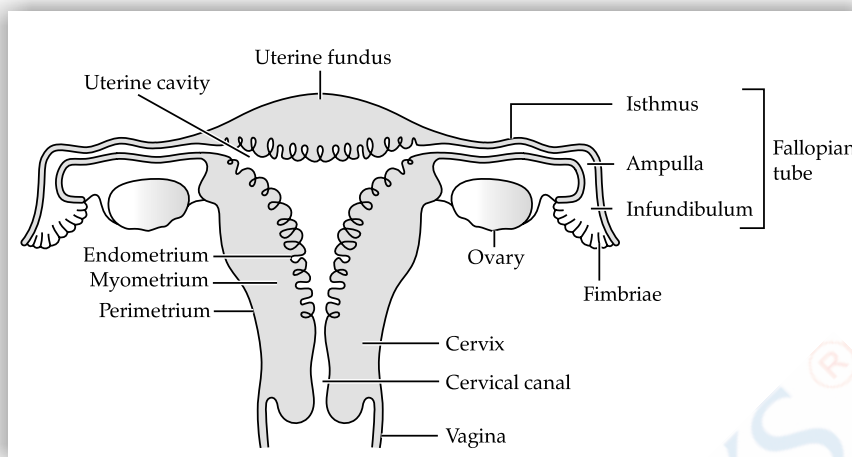

Fig 2.3: Human Female Reproductive system

Topic-2

Gametogenesis and Menstrual Cycle

Concepts Covered • Gametogenesis • Structure of Sperm • Structure of Ovum
• Menstrual Cycle



Revision Notes

► Gametogenesis

- The process of formation of gametes or sex cells is known as gametogenesis.
- It includes spermatogenesis and oogenesis.

► Spermatogenesis

- It is the process of the formation of sperms in seminiferous tubules of testes.
- It has two stages namely,
 - (a) Formation of **spermatids**
 - (b) Spermiogenesis
- During the formation of **spermatids**, spermatogonia i.e., sperm mother cells or immature male germ cells produce spermatids.
- In spermiogenesis, the spermatids are transformed into sperm.
- Each primary spermatocyte undergoes meiosis-I and produces two haploid secondary spermatocytes.
- Each secondary spermatocyte divides by meiosis-II and produces two haploid spermatids.
- Thus, four spermatids are formed from each primary spermatocyte.
- The spermatids, under the influence of FSH of the anterior pituitary, are converted into spermatozoa. The process is called spermiogenesis.
- After spermiogenesis, the sperm head become embedded in the Sertoli cells and are finally released from seminiferous tubules. The process of release of mature spermatozoa from the Sertoli cells into the **lumen** of seminiferous tubules is known as spermiation.

► Hormones in Spermatogenesis

- The hypothalamus releases a large amount of Gonadotropin-releasing hormone (GnRH).
- GnRH stimulates the anterior pituitary gland to secrete two gonadotropins namely Luteinizing hormone (LH) and Follicle stimulating hormone (FSH).
- LH acts on the Leydig cells and stimulates the synthesis and secretion of androgens which in turn stimulate the spermatogenesis.
- FSH acts on the Sertoli cells and stimulates the secretion of some spermatogenic factors which help in the process of spermiogenesis.

► Structure of Sperm

- It is a microscopic structure.
- A mature sperm measures about $60\ \mu\text{m}$ (0.06 mm) long.
- A plasma membrane envelops the whole body of sperm.

- Sperm consists of four parts namely, head, neck, a middle piece and a tail region.

(a) Head

- It is oval-shaped, consisting of a nucleus and **acrosome**.
- The **acrosome** is formed from Golgi complex which contains lytic enzymes, that help in fertilisation of the ovum.



Key Words

Spermatids: Formed after the second meiotic division from spermatocyte and develop into spermatozoa.

Acrosome: Membranous organelle located above the anterior part of the sperm nucleus containing number of hydrolytic enzymes.

(b) Neck

- Behind the head is a neck containing proximal and distal centrioles.
- The distal centriole of the neck is connected to the axial filament.

(c) Middle Piece

- It is composed of axial filament surrounded by numerous mitochondria and cytoplasm.
- Mitochondria produce energy for the sperm motility.

(d) Tail

- It consists of a central axial filament.
- The sperm moves in fluid medium and female genital tract by the undulating movement of the tail.
- Sperms are transported through the accessory ducts.
- The secretions of the epididymis, vas deferens, seminal vesicle and prostate are essential for maturation and motility of sperms.
- The seminal plasma and sperms together constitute the semen.
- The human male ejaculates about 200-300 million sperms during a coitus ejaculation.
- For normal fertility at least 60% of sperms must have a normal shape and size and 40% of them, must show vigorous motility.

Key Diagram :

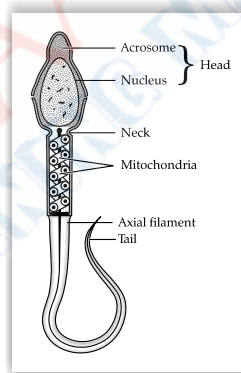
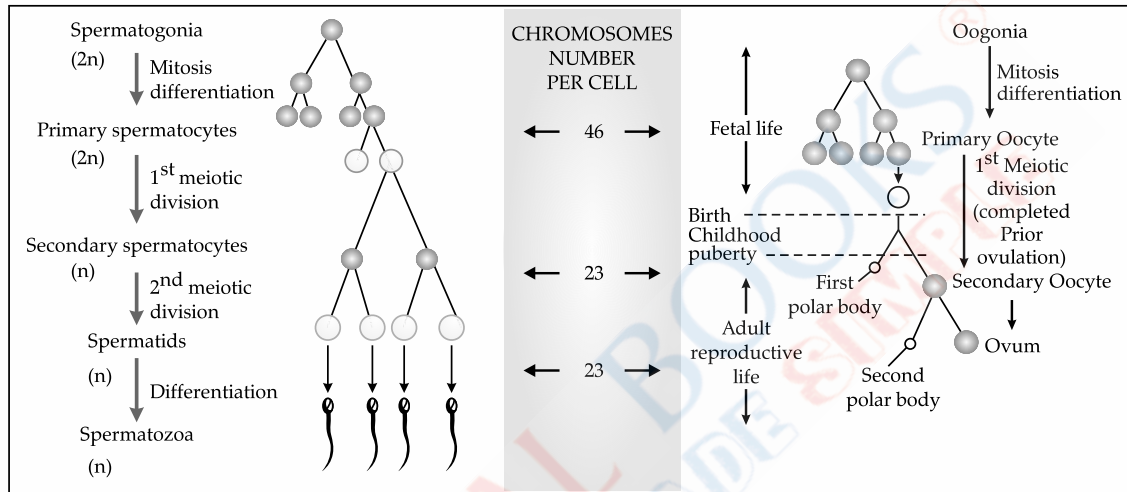

Fig 2.4 : Structure of a Sperm

► **Oogenesis**

- It is the process of formation and maturation of the ovum.
- It takes place in Graafian follicles.
- It is initiated in embryonic stage when millions of egg mother cells (oogonia) are formed within each ovary.
- No oogonia are formed and added after birth.
- Oogonia multiply to form primary oocytes which enter into prophase-I of the meiosis and get temporarily arrested at that stage.
- Each primary oocyte gets surrounded by a layer of granulosa cells to form a primary follicle.
- A large number of primary follicles degenerate during the phase from birth to puberty.
- Therefore at puberty, only 60,000-80,000 primary follicles are left in each ovary.
- The primary follicles get surrounded by more layers of granulosa cells and a new theca to form secondary follicles.
- The secondary follicles get transformed into a tertiary follicle.
- It has a fluid-filled cavity (antrum).
- The theca layer forms an inner theca interna and an outer theca externa.

- The primary oocyte within the tertiary follicle grows in size and undergoes first unequal meiotic division to form a large haploid secondary oocyte and a tiny first polar body.
- The secondary oocyte retains the nutrient-rich cytoplasm of the primary oocyte.
- It is unknown, whether the first polar body divides further or degenerates.
- The tertiary follicle further changes into the mature follicle (Graafian follicle).
- The secondary oocyte forms a new membrane (zona pellucida).
- The Graafian follicle now ruptures to release the secondary oocyte (ovum) from the ovary. This is called ovulation.

Key Diagram :**Fig 2.5 : Schematic representation of (a) Spermatogenesis (b) Oogenesis****Structure of Ovum**

- It is a spherical or oval and non-motile female gamete.
- It is about 0.2 mm in diameter.
- The human ovum is non cleidoc (without shell) and alecithal (without yolk).
- Ovum has four membranes namely,
 - Plasma membrane (Oolemma) :** Innermost layer.
 - Vitelline membrane :** Attached to the plasma membrane.
 - Zona pellucida :** Transparent non-cellular, thick, glycoprotein rich layer found outer to the vitelline membrane.
 - Corona radiata :** Outer layer is formed of follicle cells. These cells are held together by a mucopolysaccharide called hyaluronic acid.

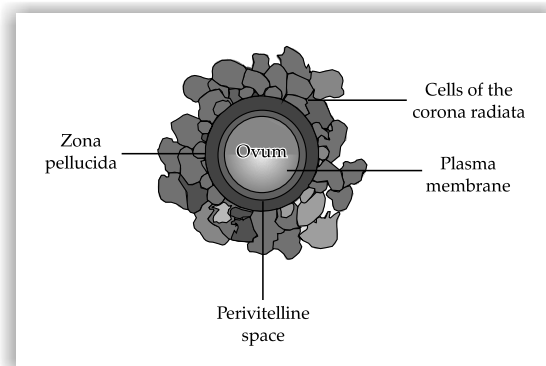
**Fig 2.6 : Structure of human ova**

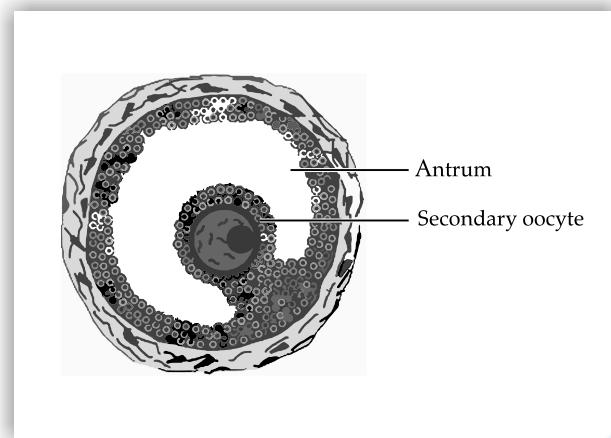

Fig 2.7 : Graafian follicle

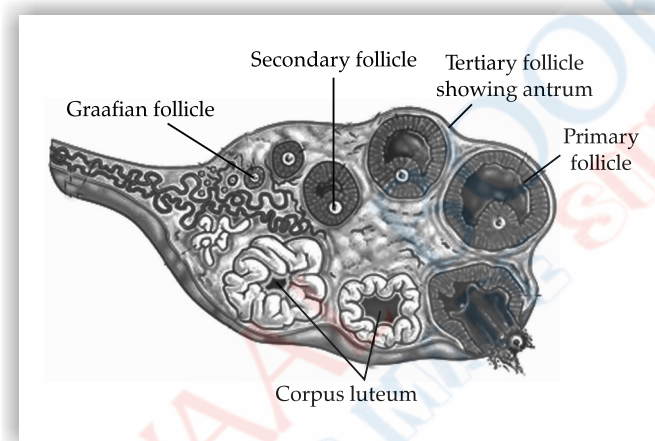

Fig 2.8 : Sectional view of ovary

► Menstrual Cycle

- The reproductive cycle in the human female and related primates is called the menstrual cycle.
- The first menstruation begins at puberty (at the age of 10-12 years) and is called menarche.
- In human females, menstruation is repeated at an average interval of about 28/29 days and the cycle of events starting from one menstruation till the next one is called the menstrual cycle.
- One ovum is released during the middle of each menstrual cycle.
- The cycle starts with the menstrual phase, when menstrual flow occurs, it lasts for 3-5 days.
- The menstrual flow results due to the breakdown of the endometrial lining of the uterus and its blood vessels which form the liquid that comes out through the vagina.
- Menstruation occurs only if the released ovum is not fertilised.
- Lack of menstruation may be indicative of pregnancy or may also be caused due to some other underlying causes like stress, poor health, etc.
- The menstrual phase is followed by the follicular phase.
- During the follicular phase, the primary follicles in the ovary grow to become a fully mature Graafian follicle and simultaneously, the endometrium of uterus regenerates through proliferation. These changes in the ovary and the uterus are induced by changes in the levels of pituitary and ovarian hormones.
- The secretion of gonadotropins (LH and FSH) increases gradually during the follicular phase and stimulates follicular development as well as secretion of estrogens by the growing follicles.
- Both LH and FSH attain a peak level in the middle of the cycle (about the 14th day).
- Rapid secretion of LH leading to its maximum level during the mid-cycle called LH surge induces rupture of Graafian follicle and thereby the release of an ovum (ovulation).
- The ovulation (ovulatory phase) is followed by the luteal phase during which the remaining parts of the Graafian follicle transform as the corpus luteum.
- The corpus luteum secretes large amounts of progesterone which is essential for the maintenance of the endometrium.
- During pregnancy, all events of the menstrual cycle stop and there is no menstruation.
- In the absence of fertilisation, the corpus luteum degenerates. This causes disintegration of the endometrium leading to menstruation, marking a new cycle.
- In human beings, the menstrual cycle ceases at around 50 years of age and is termed as menopause.

- Cyclic menstruation is an indicator of the normal reproductive phase and extends between menarche and menopause.

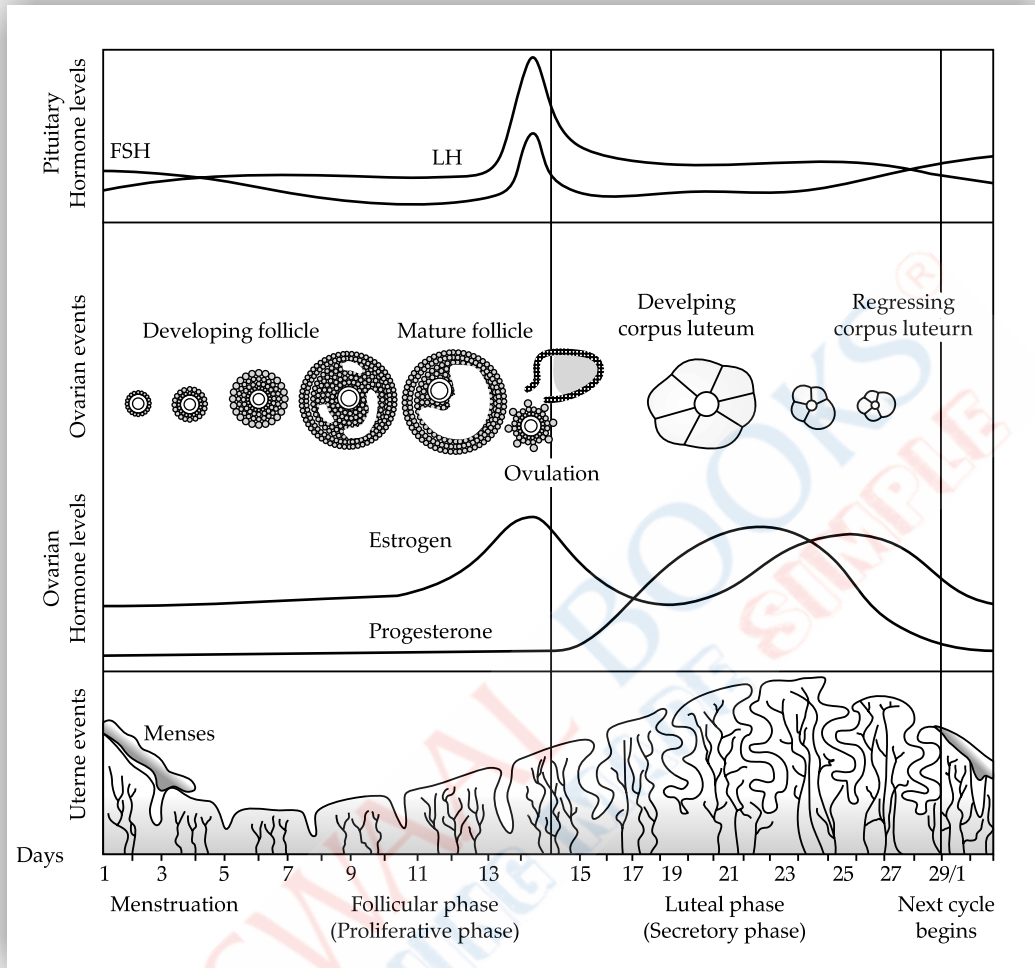

Fig 2.9 : Various events during Menstrual Cycle



Mnemonics

1. **Concept:** Structure of Sperm

Mnemonics: High Node Magnification Time

Interpretations: Head, Neck, Middle piece, Tail

2. **Concept:** Structure of Ovum

Mnemonics: Please cross Via Zebra Crossing

Interpretations: Plasma membrane Vitelline membrane, Zona pellucida, Corona radiata

Topic-3

Fertilisation and Post-Fertilisation Events

Concepts Covered • Fertilisation • Pregnancy • Placenta Formation and Functions
• Lactation • Parturition



Revision Notes

► Fertilisation

- The process of fusion of male gamete (sperm) with the female gamete (ovum) is called fertilisation.
- During copulation, semen is released through the penis into the vagina (insemination).

- After insemination, the sperms swim through the cervix and enter into the uterus and reach the ampullary-isthmic junction of the oviduct where fertilisation takes place.
- The process of fertilisation takes place as follows :
Sperms → vagina → cervical canal → uterus → isthmus

↓
Fertilisation ← Ampullary-isthmic Junction ampulla

↑
Ovum (from ovary) → fimbriae → infundibulum →

- Fertilisation (sperm + ovum → zygote) occurs only if ovum and sperms are transported simultaneously. So all copulations do not lead to fertilisation and pregnancy.
- As soon as sperm contacts with zona pellucida, it induces changes in the membrane that block entry of additional sperms.
- With the help of enzymes of the acrosome, which dissolve the zona pellucida and plasma membrane of the ovum, the sperm enters into the cytoplasm of the ovum. This induces second meiotic division of the secondary oocyte to form a second polar body and a haploid ovum (ootid).
- The haploid nuclei of the sperm and ovum fuse together to form a diploid zygote.

► Implantation

- The mitotic division (cleavage) starts as the zygote moves through the isthmus of the oviduct towards the uterus and forms 2, 4, 8, 16 daughter cells called blastomeres.
- The embryo with 8-16 blastomeres is called a **morula**.
- **Morula** continues to divide and transforms into a large mass of cells called the blastocyst, which moves further towards the uterus.



Key Word

Morula: The embryo with 8-16 celled blastomeres.

Chorionic villi: Tiny projections of placental tissue that look like fingers and contain the same genetic material as the foetus.

- The blastomeres in the blastocyst are arranged into an outer layer (trophoblast) and an inner group of cells (inner cell mass) attached to the trophoblast.
- The trophoblast layer then gets attached to the endometrium and the inner cell mass gets differentiated into three germ layers namely, outer ectoderm, middle mesoderm and inner endoderm forming 3-layered structure (gastrula) leading to the formation of the embryo.
- After attachment, uterine cells divide rapidly and cover the blastocyst.
- As a result, the blastocyst becomes embedded in the endometrium of the uterus. This is called implantation.

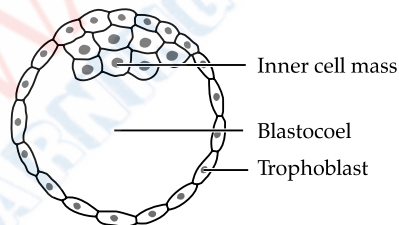

Fig 2.10: Diagram of a Blastocyst

► Pregnancy and Embryonic Development

- After implantation, the finger-like projections called **chorionic villi** appear on the trophoblast which is surrounded by the uterine tissue and maternal blood.
- The chorionic villi and uterine tissue become interdigitated with each other and form a structural and functional unit between the developing embryo and the maternal body called the placenta.
- The placenta is a structural and functional unit between the embryo (foetus) and the maternal body.
- The placenta is connected to the embryo by an umbilical cord.
- The umbilical cord helps to transport substances to and from the embryo.

► Functions of Placenta

- It acts as a barrier between the foetus and mother.
- Soluble inorganic and organic materials, nutrients, hormones, antibodies, etc. can pass through the placenta from the mother to the foetus.
- It helps in the gas exchange between mother and foetus.
- It helps to eliminate nitrogenous wastes of foetus.
- It acts as an endocrine gland by secreting several hormones like human Chorionic Gonadotropin (hCG), human Placental Lactogen (hPL), oestrogens, progesterone and relaxin.

► Pregnancy

- During pregnancy, levels of estrogen, progesterone, cortisol, prolactin, thyroxine, etc. are also increased in maternal blood.

- They support the foetal growth, metabolic changes in the mother and maintain pregnancy.
- Three germ layers (ectoderm, endoderm, mesoderm) give rise to all tissues (organs) in adults.
- The stem cells in inner cell mass have the potency to give rise to all the tissues and organs.
- Human pregnancy (gestation period) lasts 9 months (for cats : 2 months, dogs : 2 months, elephants : 21 months).

► **Changes in Embryo during Pregnancy**

- After one month of pregnancy : The heart is formed.
- End of second month : Limbs and digits are developed.
- End of 12 weeks (first trimester) : The major organs such as limbs, external genital organs etc., are well developed.
- During 5th month : The first movement of foetus and appearance of hair on the head.
- End of 24 weeks (second trimester) : Body is covered with fine hair, eyelids separate and eye lashes are formed.
- End of 9 months : Ready for delivery.

► **Parturition (Labour) and Lactation**

- The process of giving birth to young ones after the gestation period of nine months is known as parturition.
- Parturition is induced by a neuroendocrine mechanism.
- The signals originating from the foetus and placenta induce mild uterine contractions (foetal ejection reflex). This causes the release of oxytocin from the maternal pituitary.
- Oxytocin causes stronger uterine muscle contractions which in turn stimulate further secretion of oxytocin. This process is continued leading to the expulsion of the baby out of the uterus through the birth canal.
- After parturition, the umbilical cord is cut off.
- The placenta and remnants of the umbilical cord are expelled from the maternal body after parturition. This is called "after birth".

► **Lactation**

- The mammary glands produce milk towards the end of pregnancy by the process called lactation.
- The yellowish milk produced during the initial few days of lactation is called colostrum.
- The colostrum contains several antibodies essential to develop resistance for newborn babies.

CHAPTER-3

REPRODUCTIVE HEALTH



Revision Notes

► **Reproductive Health**

- The term 'reproductive health' simply refers to healthy reproductive organs with normal functions. According to WHO (World Health Organisation), the word 'reproductive health' means a total well-being in all aspects of reproduction i.e., physical, emotional, behavioural and social.
- Thus, a society with people having physically and functionally normal reproductive organs and normal emotional and behavioural interactions among them in all sex-related aspects might be called reproductively healthy.

► **Problems Associated with Reproductive Health :**

- Rapid increase in the human population is called population explosion.
- Lack of awareness and sex education in people.
- Spread of myths and misconceptions about sex-related aspects.
- Common occurrence of sexually transmitted diseases due to lack of knowledge of hygiene of reproductive organs.
- Illegal abortions and female **foeticides**.
- Sex abuse and sex-related crime.

► **Strategies of Reproductive Health Programmes:** To ensure total reproductive health, several programmes like reproductive health programmes and family planning were started in 1951.



Key Words

Foeticide : Destruction or abortion of a foetus.

Pre-natal : Before birth

Post-natal : After birth

► **The aims of Reproductive and Child Care Programmes :**

- Create awareness in both males and females about various reproductive aspects with the help of audio-visual and print media by both Government and Non-Government agencies.

- (b) Provide **sex education** in schools to save the young generation from myths and misconceptions about sex related issues.
- (c) **Prevention and control of sexually transmitted diseases** by providing the correct information about reproductive organs, adolescence and safe and hygienic sexual practices.
- (d) **Educate the fertile couples** and those in marriageable age about birth control devices, **pre-natal** and **post-natal** care of mother and child, importance of breast-feeding, etc.
- (e) Provide awareness about **ill-effects of population explosion, sexual abuses, sex discrimination and sex related crimes**.
- (f) **Provide medical facilities and support** like infra structural facilities, professional expertise and material support to decrease maternal and infant mortality rates.
- (g) Reduce the **problem of infertility** by promoting Assisted Reproductive Techniques (ARTs).

► **Steps Taken to Maintain a Reproductively Healthy Society**

1. Imposing a statutory ban on amniocentesis (analysis of amniotic fluid-Foetal Sex Determination.)
2. Rigorous implementation of **immunisation** programs.
3. Creation of specialised health centres like infertility clinic for diagnosis and corrective treatment of some infertility disorders.
4. Better awareness about sex-related matters and sex-related problems, etc.
5. Increase in the number of medically assisted deliveries and better post-natal care.
6. Increase in the number of couples with small families.
7. Early detection and cure of STDs.

► **Reasons for Population Explosion** : Tremendous increase in size and growth rate of population is called population explosion. It is due to :

1. Rapid decline in death rate.
2. More longevity, longer life span.
3. Advanced medical facilities.
4. Prevention of diseases.
5. Developed techniques in agriculture.
6. Better transport facilities.
7. Protection from natural factors.
8. Increase in the number of people of reproductive age.

► **Consequences of Population Explosion** : Poverty, unemployment, shortage of food, unhygienic conditions, education problems, residential problems, pollution, crime, excessive consumption of natural resources etc.

► **How to Control Over Population ?**

- (i) People should be given education regarding the advantages of small family and family planning methods.
- (ii) Increasing the age of marriage.
- (iii) Incentives to those families, who are adopting family planning methods.
- (iv) Birth control through vasectomy and tubectomy.
- (v) Family planning programmes with the slogan 'Hum Do Hamare Do'.

► **Birth Control Measures :**

The most important step to overcome this problem is to encourage smaller families by using various contraceptive methods. The contraceptive methods help to prevent unwanted pregnancies.

► **An ideal contraceptive should be**

- User-friendly, easily available, effective and reversible.
- With no or least side-effects.
- Non-interfering with sexual drive, desire & sexual act.



Key Words

Immunisation : A process of making an individual immune to infection (Protecting against disease by the use of vaccine)

Abstinence : Practice of refraining oneself from sexual intercourse, stimulants, food etc.

► They are grouped as follows :

1. **Natural or Traditional Methods** : These methods of birth control depend upon the natural rhythm of a woman. These include the following methods :

- (a) **Coitus interruptus** : This involves withdrawing the penis by the male partner before ejaculation so that semen is not deposited in the vagina. It is the oldest method of voluntary fertility control. This method has certain limitations:
 - Some sperms may be deposited in the vagina even before the sexual climax.
 - May develop physiological and psychological problems for both partners.

- (b) **Periodic abstinence** : A week before and a week after the menstrual phase are supposed to be safe periods for sexual intercourse. It reduces the chances of pregnancy by about 80 percent.
The period from 10th to 17th day (both days included) of the menstrual cycle is called danger or risk or fertile period and unprotected sexual intercourse should be avoided during this period.
- (c) **Lactational amenorrhea** : It has been noticed that during the period of intense lactation after the parturition, the mother does not undergo menstruation and ovulation so, the chances of conception are nearly nil. It also has no side effects but it is effective only up to a maximum period of six months after parturition.
2. **Artificial Methods** : This involves mechanical or barrier methods.
- (a) **Condoms** : These are rubber or latex sheaths that are put on the penis before coitus (copulation). These are popularly called 'Nirodh'. These check pregnancy by preventing the deposition of sperms in the vagina. These can be self-inserted to give privacy to the user. These also prevent the spread of sexually transmitted diseases (STDs) including AIDS, syphilis, etc. Female condoms are also available called femidoms.
- (b) **Diaphragms and cervical caps** : These are mechanical barriers made of rubber and fitted in the vagina of a female to check the entry of sperms in the uterus. These are reusable.
- (c) **Intra Uterine Devices (IUDs)** : These are inserted by doctors or expert nurses in the uterus through the vagina. These include :
- Non-medicated IUDs (e.g., Lippes loop)
 - Copper releasing IUDs (e.g., Copper T)
 - Hormone releasing IUDs (e.g., Progestogen) : Make the uterus unsuitable for **implantation** and the cervix hostile to the sperms.
 - IUDs increase the phagocytosis of sperms. The Cu ions suppress the motility and fertilising capacity of sperms.
 - IUDs are ideal contraceptives for females who want to delay pregnancy or spacing in children.
3. **Chemical Methods** : These are of the following types :
- (i) **Spermicidal tablets, jellies, paste and creams** introduced in the vagina before coital activity. These kill sperms. Common spermicidal chemicals used are lactic acid, citric acid, potassium permanganate, zinc sulphate etc.
- (ii) **Physiological (Oral) Devices** : These are the hormonal preparation in the form of pills for females.
- The pills are usually small doses of progestogens or progestogen–estrogen combinations in the form of tablets (pills).
 - Pills are taken daily for 21 days starting within the first five days of the menstrual cycle. After a gap of 7 days (during which **menstruation** occurs) it has to be repeated in the same pattern as long as the female desires to prevent conception.
 - They inhibit ovulation and implantation as well as alter the quality of cervical mucus to prevent the entry of sperms.
 - Pills are very effective with lesser side effects.
 - **Saheli** : It is a new oral contraceptive for females. It was developed by the **Central Drug Research Institute (CDRI)** Lucknow. It contains a non-steroidal preparation. It is a 'once a week' pill with very few side effects and high contraceptive value.
 - **Drawbacks of Oral Contraceptives** : Nausea, abdominal pain, breakthrough bleeding, irregular menstrual bleeding, breast cancer etc.
- (iii) **Injectables/Implants**
- Progestogens alone or in combination with an oestrogen is used by females as injections or implants under the skin.
 - Their mode of action is similar to that of pills and their effective periods are much longer. These are also effective within 72 hours of coitus. Thus it has been found to very effective as emergency contraceptives.



Key Words

Implantation : The attachment of fertilised egg to the wall of uterus at the beginning of pregnancy.

Menstruation : Vaginal bleeding in women as a part of monthly cycle.

Coitus : Sexual intercourse

4. **Sterilisation or Surgical Methods** : These methods block gamete transport and so prevent conception. These include the following measures :
- (a) **Male sterilisation** : It is a permanent method of birth control in which either testes are surgically removed, called castration, or cutting of the vas deferens, called **Vasectomy**. The vas deferens is exposed and cut through a small incision on the scrotum to prevent the passage of sperms.
- (b) **Female sterilisation** : Methods of female sterilisation include :
- (i) Ovariectomy involves surgical removal of ovaries.
- (ii) **Tubectomy** involves cutting or tying up of fallopian tubes through a small incision in the abdomen or through vagina.
- (iii) Tubal ligation involves blocking of fallopian tubes by an instrument called a laparoscope.

- ▶ **Medical Termination of Pregnancy (MTP)**
 - Intentional or voluntary termination of pregnancy before full term is called MTP or induced abortion.
 - 45 to 50 million MTPs are performed in a year all over the world (i.e., 1/5th of the total number of conceived pregnancies).
 - MTP helps to decrease the population.
 - Because of emotional, ethical, religious and social issues many countries have not legalised MTP.
 - Government of India legalised MTP in 1971 with some strict conditions to check indiscriminate and illegal female foeticides which are reported to be high in India.
- ▶ **Importance of MTP**
 - To avoid unwanted pregnancies due to casual intercourse or failure of the contraceptive used during **coitus or rapes**.
 - Essential in cases where continuation of the pregnancy could be harmful to the mother or to the foetus or both.
 - MTPs are safe during the first trimester, (up to 12 weeks of pregnancy). 2nd-trimester abortions are very risky.
- ▶ **Problems Related to MTPs**
 - Majority of the MTPs are performed illegally.
 - Misuse of amniocentesis (a foetal sex determination test based on the chromosomal pattern in the amniotic fluid).
 - MTP for a female child causes sex imbalance in society.
- ▶ **Amniocentesis**
 - It is a prenatal diagnostic method to determine the sex of the developing baby. This method has both positive and negative application. This method is legally banned in India.
 - (a) **Positive application**
 - It helps to detect any genetically controlled congenital disease or any metabolic disorders in the foetus.
 - (b) **Negative application**
 - People use this method for female foeticide, which causes sex imbalance in society.
- ▶ **Sexually Transmitted Diseases (STDs)**
 - **Diseases transmitted through sexual intercourse are called Sexually transmitted diseases (STDs)/Venereal diseases (VD) or Reproductive tract infections (RTI).** e.g., Gonorrhoea, syphilis, genital herpes, **chlamydia**, genital warts, trichomoniasis, hepatitis-B and HIV leading to AIDS.
 - **Hepatitis-B and HIV are also transmitted:**
 - (a) By sharing of injection needles, surgical instruments, etc.
 - (b) By transfusion of blood.
 - (c) From infected mother to foetus.
 - Except Hepatitis B, genital herpes, HIV and other diseases are completely curable if detected early and treated properly.
 - **Early symptoms :** Itching, fluid discharge, slight pain, swellings, etc., in the genital region.
 - Absence or less significant early symptoms and the social stigma deter the infected persons to consult a doctor. This leads to pelvic inflammatory diseases (PID), abortions, stillbirths, ectopic pregnancies, infertility, cancer of the reproductive tract, etc.
 - All persons are vulnerable to STDs. These are very high among persons in the age group of 15-24 years.
 - **Prevention :**
 - (a) Avoid sex with unknown partners/multiple partners.
 - (b) Always use condoms during coitus.
 - (c) In case of doubt, go to a qualified doctor for early detection and get complete treatment.
- ▶ **Infertility**
 - It is the inability of male or female to produce children.
 - The reasons for this may be physical, congenital, diseases, drugs, immunological or even psychological.
- ▶ **Assisted Reproductive Technologies (ART)**
 - (1) **In vitro fertilisation (IVF- test tube baby programme) :** In this method, ova from the wife/donor and sperms from the husband/donor are collected and are induced to form zygote under simulated conditions in the laboratory. This is followed by Embryo transfer (ET). It is of 2 types :
 - (a) **Zygote Intra Fallopian Transfer (ZIFT) :** Transfer of zygote or early embryos (with up to 8 blastomeres) into the fallopian tube.
 - (b) **Intra Uterine Transfer (IUT) :** Transfer of embryos with more than 8 **blastomeres** into the uterus. The embryo formed by *in vivo* fertilisation (fertilisation within the female) is also used for such transfer to assist those females who cannot conceive.



Key Words

Chlamydia : A sexually transmitted disease caused by the bacteria *chlamydia trachomatis*. The disease infects both men and women.

Blastomeres: Cells formed by the cleavage of zygote or fertilised ovum which later produce morula.

(2) **Gamete Intra Fallopian Transfer (GIFT)** : Transfer of an ovum from a donor into the fallopian tube of another female who cannot produce ovum, but can provide a suitable environment for fertilisation and development.

(3) **Intra Cytoplasmic Sperm Injection (ICSI)** : A laboratory procedure in which a single sperm (from a male partner) is injected directly into an egg (from a female partner). Then the fertilised egg is implanted into the woman's uterus.

(4) **Artificial Insemination (AI) technique:**

- The semen collected from the husband or a healthy donor is artificially introduced into the vagina or the uterus (IUI- intra-uterine insemination) of the female.
- This technique is useful for the male partner having an inability to inseminate female or low sperm counts, etc.

(5) **Surrogacy**

- Here, a woman (surrogate mother) bears a child for a couple unable to produce children, because the wife is infertile or unable to carry.
- The surrogate is impregnated either through artificial insemination or through the implantation of an embryo produced by *in vitro* fertilisation.

► **Problems of ART**

- It requires high precision handling by specialized professionals and expensive **instrumentation**. Therefore, these facilities are available only in very few centres and are affordable to only a limited number of people.



Key Word

Instrumentation: The use or application of instruments to carry out some specific task.



Mnemonics

Concept: Sexually Transmitted Diseases (STDs)

Mnemonics: Haryana Government School Head Girl

Interpretations: Hepatitis B, Genital herpes, Syphilis HIV, Gonorrhoea.

UNIT – VII: GENETICS AND EVOLUTION

CHAPTER-4

PRINCIPLES OF INHERITANCE AND VARIATION

Topic-1

Mendel's laws and Chromosomal Theory

Concepts Covered • Heredity, variation, Mendel's laws of Inheritance, Non-Mendelian inheritance, Chromosomal theory, Linkage and Recombination.



Revision Notes

- **Heredity (L. hereditas - heirship or inheritance)** : It is the sum of all biological processes by which particular characteristics are passed on from parents to their offspring, either through asexual or sexual reproduction.

- **Variation:** Tendency of differences in various traits of individuals of a progeny from one another and their parents.

Mendel's Laws of Inheritance :

- **Hybridization Experiments on Garden Pea (*Pisum sativum*)**

- Mendel selected 7 pairs of contrasting traits of true breeding pea varieties.

S. No.	Characters	Dominant	Recessive
1.	Height of the stem	Tall (T)	Dwarf (t)
2.	Colour of the flower	Violet/ Red (R)	White (r)
3.	Position of the flower	Axial (A)	Terminal (a)
4.	Shape of pod	Full/ Inflated (I)	Constricted (i)
5.	Colour of pod	Green (G)	Yellow (g)
6.	Shape of seed	Round (R)	Wrinkled (r)
7.	Colour of seed/cotyledons	Yellow (Y)	Green (y)

Inheritance of One Gene

► Monohybrid Cross :

- A cross involving two plants differing in one pair of contrasting characters.
- e.g., Mendel crossed tall and dwarf pea plants to study the inheritance of one gene.

► Steps in Making a Cross of Pea :

- Selection of two pea plants with contrasting characters.
- Removal of anthers (emasculation) of one plant to avoid self-pollination. This is a female parent now.
- Collection of pollen grains from the other plant (male parent) and transfer to female parent for pollination.
- Collection of seeds and production of offspring.
- Mendel made similar observations for other pairs of traits and proposed that factors were inherited from parent to offspring. Later, these factors were called genes.
- The **F₁ generation** (Tt) when self-pollinated, produces gametes T and t in equal proportion.
- Mendel self-pollinated the **F₂ generation** plants.
- He found that dwarf F₂ plants continued to generate dwarf plants in F₃ & F₄ generation.
- He concluded that the **genotype** of the dwarf was homozygous- *tt*.

► Monohybrid Phenotypic Ratio : 3 Tall : 1 Dwarf = 3 : 1

► Monohybrid Genotypic Ratio :

1 Homozygous tall (TT) : 2 Heterozygous tall (Tt) : 1 Homozygous dwarf (tt)

► Back cross and Test cross

- **Back cross** : Crossing of F₁ hybrid with either of its parent.
- **Test cross** : Crossing of an F₁ hybrid with its recessive parent (Test cross ratio=1:1). It is used to find out the unknown genotype. Mendel conducted a test cross to determine the F₂ genotype.

Mendel's Principles or Laws of Inheritance :

1. Principle of Dominance

- Characters are controlled by discrete units called factors.
- Factors occur in pairs.
- In a dissimilar pair of factors or contrasting **alleles** i.e., in heterozygous condition, only one member of the pair expresses its effect in the hybrid and is called dominant while the manifestation of the other is masked and is called recessive.

2. Law of Segregation

This law states that allelic pairs separate or segregate during gamete formation and randomly unite at fertilization, thus homozygous parent produces similar gametes. Heterozygous parent produces two kinds of gametes, each having one allele in equal proportion.

The Concept of Dominance

- In heterozygotes, there are dominant and recessive alleles.
- The normal (unmodified or functioning) allele of a gene produces a normal enzyme that is needed for the transformation of a substrate.
- The modified allele is responsible for the production of
 - (i) The normal/less efficient enzyme or
 - (ii) A non-functional enzyme or
 - (iii) No enzyme at all
- **In the first case** : The modified allele will produce the same phenotype like the unmodified allele. It becomes dominant.
- **In 2nd and 3rd cases** : The **phenotype** is dependent only on the functioning of the unmodified allele. Here, the modified allele becomes recessive.

Key Words

Alleles or allelomorphs : A pair of Mendelian factors or genes located on the same locus of two homologous chromosomes of an individual which control the expression of a trait or character are called alleles or allelomorphs.

F₁ generation: Hybrids Produced from a cross between the genetically different individuals called parents. e.g., Tt individuals are produced in F₁ generation from a cross between TT and tt parents.

F₂ generation : It is the generation of individuals which arises as a result of interbreeding or selfing amongst individuals of F₁ generation.

Genotype : (Gk. Geno-race; typos — image). It is the genetic constitution of individual with regard to one or more characters irrespective that whether the genes are expressed or not, for e.g., genotype of hybrid tall pea plant is Tt, pure tall TT and pure dwarf tt.

Phenotype : (Gk. Pheno — to appear, typos — image): It is observable or measurable distinctive structural or functional characteristic of an individual. e.g., phenotypic tall pea plant can be genotypically TT or Tt.

Non-Mendelian Inheritance

(a) Incomplete Dominance

- It is an inheritance in which heterozygous offspring shows an intermediate character between two parental characteristics. e.g., Flower colour in Snapdragon (dog flower or *Antirrhinum* sp.) and *Mirabilis jalapa* (4'O clock plant).
- Here, phenotypic and genotypic ratios are the same.
- Phenotypic ratio = 1 Red : 2 Pink : 1 White
- Genotypic ratio = 1 (RR) : 2 (Rr) : 1(rr)
- This means that R was not completely dominant over r.

Key Fact

Mendel, besides pea plant, also worked on Hawkweed (*Hieracium*) and lablab. But he failed to obtain same results as he found availability and in garden pea due to parthenogenesis and non-availability of pureline seeds.

(b) Co-dominance

- It is the inheritance in which both alleles of a gene are expressed equally and independently in a hybrid i.e., both the alleles are dominant e.g., ABO blood grouping in humans.
- ABO blood groups are controlled by the gene.
- The gene (*I*) has three alleles *I^A*, *I^B* and *i*. However, a person can have any two of these three alleles. *I^A* and *I^B* both are dominant alleles while *i* is a recessive allele.
- The alleles *I^A* and *I^B* produce antigen A and antigen B respectively on the RBC surface while allele *i* doesn't produce any antigen.
- When *I^A* and *I^B* are present together they both express their types of surface antigen A and B. This is due to co-dominance.

(c) Multiple Allelism

- Here, more than two alleles govern the same character.
- Since in an individual, only two alleles are present, multiple alleles can be found only when population studies are made e.g., ABO blood grouping (3 alleles : *I^A*, *I^B* & *i*). The skin colour and height of humans are also examples of multiple alleles.

(d) Pleiotropy

- Pleiotropy is the phenomenon in which one gene controls many traits. For example, the gene in pea plants that controls the round and wrinkled texture of seeds also influences the phenotypic expression of starch grain size.
- So, if the starch grain size is considered as the phenotype, then from this angle, the alleles show incomplete dominance.
- Therefore, dominance is not an autonomous feature of a gene or the product that it has information for. It depends as much on the gene product and the production of a particular phenotype.

Inheritance of Two Genes

► Dihybrid Cross

- A cross between two parents differing in two pairs of contrasting characters.
- Mendel made some dihybrid crosses e.g., Cross between the pea plants with round shaped and yellow coloured seeds (RRYY) and wrinkled shaped and green coloured seeds (rryy).
- On observing the F₂ generation, Mendel found that the yellow and green colour segregated in a 3:1 ratio.
- Round and wrinkled seed shape also segregated in a 3:1 ratio.

- Thus, the segregation of one pair of contrasting characters (Round and wrinkled shape) is independent of the segregation of another pair of contrasting character (yellow and green) colour and also that some new combinations of character appear in F_2 generation as the alleles get randomly rearranged in the offsprings at the time of fertilization.
- Dihybrid genotypic ratio: 1 : 2 : 2 : 4 : 1 : 2 : 1 : 2 : 1
 $RRYY = 1$; $RRYy = 2$; $RrYY = 2$; $RrYy = 4$; $RRyy = 1$; $Rryy = 2$; $rrYY = 1$; $rrYy = 2$; $rryy = 1$
- **Dihybrid Phenotypic ratio :**
 Round yellow 9 : Round green 3 : Wrinkled yellow 3 : Wrinkled green : 1, i.e., 9 : 3 : 3 : 1
 The ratio 9 : 3 : 3 : 1 can be derived as a combination series of 3 yellow : 1 green, with 3 round : 1 wrinkled.
 i.e., $(3 : 1)(3 : 1) = 9 : 3 : 3 : 1$

3. Mendel's Law of Independent Assortment :

- It states that when more than one pair of characters are involved in a cross, the segregation of one pair of contrasting characters is independent of the segregation of other pair of contrasting characters and also that new recombinations of characters along with the parental type also appear in the F_2 generation.

► Non-recognition of Mendel's work

- **Mendel's work remained unrecognizable till 1900 because :**
 - (a) Communication was not easy.
 - (b) Non-recognition of Mendel as a scientist.
 - (c) His mathematical approach was new and unacceptable.
 - (d) He used statistical calculations which were beyond the comprehension of the biologists of his time.
 - (e) Chromosomes, mitosis and meiosis were not known in Mendel's time.
 - (f) The concept of genes (factors) as stable and discrete unit was not accepted. Mendel could not explain the continuous variations seen in nature.
 - (g) Mendel could not provide any physical proof for the existence of factors.
- In 1900, de Vries of Holland, Correns of Germany & Von Tschermak of Austria independently rediscovered Mendel's results and proclaimed their conclusions as Mendel's Laws of inheritance.

► Chromosomal Theory (1902)

- The Chromosomal theory was proposed independently by Walter Sutton and Theodore Boveri in 1902.
- Walter Sutton & Theodore Boveri proposed that the pairing and separation of a pair of chromosomes during meiosis lead to the segregation of pair of factors.
- Sutton united chromosomal segregation with Mendelian principles and called it the Chromosomal Theory of Inheritance.
- **It states that :**
 - (a) Chromosomes are vehicles of heredity i.e., they are transmitted from parents to offspring.
 - (b) Two identical chromosomes form a homologous pair. Genes are present in a linear fashion on chromosomes.
 - (c) They segregate at the time of gamete formation.
 - (d) Independent pairs segregate independently of each other.
 - (e) Chromosomes are mutable.
 - (f) Sex chromosomes determine the sex of an individual.

Parallelism between Genes (Mendelian factors) & Chromosomes :

- Mendelian factors as well as chromosomes are transferred from generation to generation.
- The chromosomes occurs in homologous pairs. The genes also occurs in pairs (allelic pairs).
- Both chromosomes and genes segregate at the time of gamete formation in such a way that gametes receive only one chromosome & similarly one allele of each pair.
- Different pairs of chromosomes segregate independently of each other. Similarly, one pair of alleles segregates independently of another pair.
- Fusion of two (male & female) gametes brings about the diploid chromosome number as well as the allelic pairs in the offsprings.
- **Thomas Hunt Morgan** proved the Chromosomal Theory of Inheritance using fruit flies (*Drosophila melanogaster*).

He took fruit flies as a suitable material because :

- (a) It breeds very quickly.
- (b) Short generation time (life cycle : 12-14 days).
- (c) Breeding can be done throughout the year.
- (d) Hundreds of progenies are produced per mating.
- (e) They can grow on a simple synthetic medium.
- (f) Male and female flies are easily distinguishable.

► Linkage and Recombination

- **Recombination :** It is a process by which pieces of DNA are broken and recombined to produce a new combination of alleles.

- **Linkage** : Physical association of two or more genes on a chromosome, which show the tendency to inherit together. They do not show independent assortment.
- Morgan et. al crossed yellow body and white eyed females with wild type brown body and red-eyed males and inter-crossed F₁ offsprings. He found that the two genes did not segregate independently, resulted in deviation from normal dihybrid ratio 9 : 3 : 3 : 1 in F₂ generation because the appearance of parental combinations were higher than the non-parental and new recombinations.
- Morgan further carried out several dihybrid test crosses in *Drosophila* to study sex-linked genes.
Cross A : Double recessive, yellow-bodied, white-eyed females (yw/yw) X hybrid brown-bodied, red-eyed males (Y^W/YW) (wild type).
Cross B : Double recessive, white-eyed, miniature winged (wm/wm) X hybrid red eyed, large winged (W^m/Wm) (wild type).
- **Morgan in the above crosses found that :**
 - (a) The two genes did not segregate independently of each other and the F₂ ratio deviated from the 9 : 3 : 3 : 1 ratio.
 - (b) Genes were located on the X chromosome.
 - (c) When two genes were situated on the same chromosome, the proportion of parental gene combinations was much higher than the non-parental type. This is due to linkage.
 - (d) Genes for white and yellow were very tightly linked and showed only 1.3% new recombination while white and miniature wings showed 37.2% recombination (loosely linked).
 - (e) Tightly linked genes show low recombination.
 - (f) Loosely linked genes show high recombination.

The strength of linkage is inversely proportional to the distance between two linked genes. Thus, the linkage between y & w alleles is stronger than the linkage between w & m alleles.
- **Linkage groups** : All the genes present together on a single chromosome make up a linkage group. The total number of linkage groups in an organism is equal to its haploid number of chromosomes or number of homologous pairs in diploid organisms.
- Alfred Sturtevant used the recombination frequency between gene pairs as a measure of the distance between genes and 'mapped' their position on the chromosome.
- Recombination frequency or the cross over value (COV) can be calculated by the following formula.

$$\text{COV} = \frac{\text{Number of recombinants}}{\text{Total number of offsprings}} \times 100$$

- Genetic maps are used as a starting point in the sequencing of genomes as was done in Human Genome Project.



Mnemonics

Concept: Non-Mendelian Inheritance

Mnemonics: I Care Mendel's Principles.

Interpretations: Incomplete dominance, Co-dominance, Multiple alleles, Pleiotropy

Example 1

- Q. In a garden pea plant, the flowers may be axial (A) position. Find out the proportion of terminal (a) in position. Find out the proportion the offspring in the following crosses would be expected to be terminal in position.

- (i) Aa × Aa
- (ii) AA × Aa

Sol. (i)

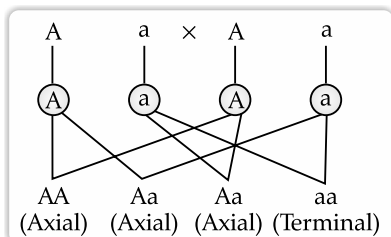

25 percent of the offspring are terminal in position

(ii)

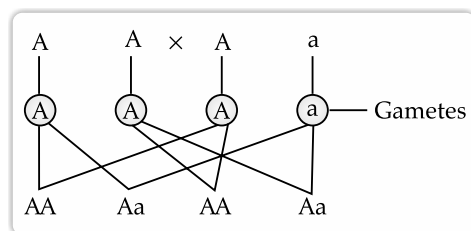

None of the offspring is terminal in position

Topic-2

Sex Determination and Chromosomal Disorder

Concepts Covered • Sex determination, Mendelian disorders, chromosomal disorders.



Revision Notes

Sex determination

- The method by which the distinction between male and female is established in a species is called sex determination.
- Sex of an individual is finalized at the time of zygote formation.

Autosomes and Sex chromosomes (allosomes)

- Autosomes are chromosomes other than sex chromosomes. They contain genes that determine somatic characteristics.
- Number of autosomes is the same in males and females.
- Sex chromosomes (X & Y) are the chromosomes that are involved in sex determination.
- Henking (1891)** studied spermatogenesis in some insects and observed that 50 % of sperm received a nuclear structure after spermatogenesis, whereas the other 50 % of sperms did not receive it.
- Henking called this structure as the **X body** (later it was called as **X-chromosome**).

Mechanism of Sex Determination

(i) **Chromosomal sex determination** : It is based on heterogamety i.e., the occurrence of two types of gametes in one of the two sexes. It is of the following types :

(a) XX-XO mechanism :

Here, the male is **heterogametic** i.e., XO besides autosomes (gametes with X and gametes without X) and female is **homogametic** i.e., XX (all gametes are with X chromosomes).

(b) XX-XY mechanism :

Male is heterogametic (X & Y) and female is homogametic (X only). e.g., Human and *Drosophila*.

(c) ZZ-ZW mechanism :

Male is homogametic (ZZ) and female is heterogametic (Z & W). e.g., Birds.

(d) ZO-ZZ mechanism : Females have only Z-chromosomes besides autosomes and males have a pair of Z-chromosomes e.g., in cockroaches.

XX-XO & XX-XY mechanisms show male heterogamety. ZZ-ZW mechanism shows female heterogamety.

Females have only Z chromosome besides autosomes and males have a pair of Z chromosome as seen in cockroaches.

Example 2

Q. Show the process of sex-linked inheritance of colour blindness

(a) If a colour-blind man (X^cY) marries a girl with normal vision (XX). Show the possibility of normal boy and carrier girl.

Sol.

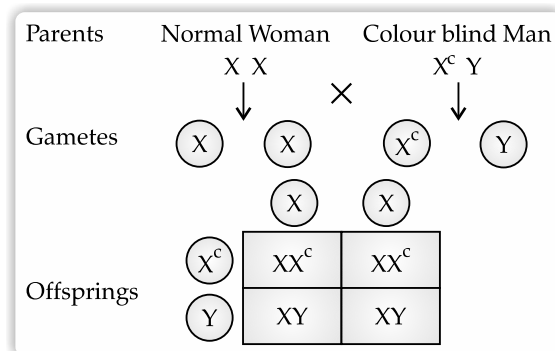

Result shows that 50 percent offspring are girls and they are carrier and 50 percent offspring are boys but they are normal.

Sex Determination in Humans (XX-XY type)

- Human has 23 pairs of chromosomes (22 pairs are autosomes and 1 pair is sex chromosome).

- A pair of X-chromosome (XX) is present in the female, whereas the X and Y chromosome are present in male.
 - During spermatogenesis, males produce 2 types of gametes i.e., 50 % with X-chromosome and 50 % with Y-chromosome.
 - Females produce the only ovum with X-chromosome.
 - There is an equal probability of fertilization of the ovum with the sperm carrying either the X or Y chromosome.
 - The sperm determines whether the offspring will be male or female.
- (ii) **Environmental Sex-determination** : Determination of sex depends upon the environmental condition. Environmental factors like temperature, etc., determine whether the zygote will develop into male or female. e.g., In turtles and crocodile.
- (iii) **Genetic balance mechanism of sex determination** : The sex of the individual is decided by the ratio of X-chromosome and autosome, as it is found in *Drosophila*.
- (iv) **Cytoplasmic Sex-determination** : Cytoplasmic or fertility factor called as an F⁺ factor located in plasmid determines the sex as it is found in some bacteria.
- **Genetic Disorders**
- There are two types of genetic disorders namely, Mendelian disorders and Chromosomal disorders.
- (1) **Mendelian Disorders**
- It is caused by alteration or mutation in a single gene.
 - The pattern of inheritance of Mendelian disorders can be traced in a family by the pedigree analysis. e.g., Haemophilia, Cystic fibrosis, Sickle-cell anaemia, Colour blindness, Phenylketonuria, Thalassaemia, etc.
 - Mendelian disorders may be dominant or recessive.



Mnemonics

Concept: Mendelian Disorders

Interpretations: Haemophilia, Thalassaemia, Cystic fibrosis, Colour blindness.

Mnemonics: Highlight The Concepts Clearly

- (a) **Colour blindness**
- It is a recessive sex-linked trait in which the eye fails to distinguish red and green colours.
 - The normal gene and its recessive allele are carried by X-chromosome.
 - In female, colour blindness appear when both the sex chromosomes carry the recessive gene.
- (b) **Haemophilia (Royal disease)**
- Sex-linked recessive disease.
 - In this, a protein involved in the blood clotting is affected.
 - A simple cut results in non-stop bleeding.
 - The heterozygous female (carrier) for haemophilia may transmit the disease to sons.
 - The possibility of a female becoming a haemophilic is very rare because mother has to be at least carrier and the father should be haemophilic (inviable in the later stage of life).
 - Queen Victoria was the carrier of this disease. So her family pedigree shows many haemophilic descendents.
- (2) **Chromosomal Disorders**
- They are caused due to the absence or excess or abnormal arrangement of one or more chromosomes.
 - These are of two types namely,
 - (a) Aneuploidy
 - (b) Euploidy.
- (a) **Aneuploidy**
- The gain or loss of chromosomes due to failure of segregation of chromatids during cell division. It includes,
 - (a) **Nullisomy (2n-2)** : A complete homologous pair is lost from diploid set.
 - (b) **Monosomy (2n-1)** : One chromosome is lost from the diploid set.
 - (c) **Trisomy (2n+1)** : One chromosome is added to the diploid set, so that one chromosome occurs in triplicate.
 - (d) **Tetrasomy (2n+2)** : Two chromosomes are added to the diploid set, so that a chromosome is found in quadruplicate.
- (b) **Polyploidy (Euploidy)**
- It is an increase in the number of chromosomes sets beyond the diploid X condition (2n).
 - This is often seen in plants.
 - Based on the number of chromosome sets, the polyploid are of the following types : triploids (3n), tetraploids (4n), pentaploids (5n), hexaploids (6n), etc.

- (a) **Autopolyploidy** : It is an increase in number of the same genome. e.g., AAA (autotriploid), AAAA (autotetraploid), etc.
- (b) **Allopolyploidy** : It is the increase in the number of sets of chromosome due to the coming together of diploid genomes of two or more than two individuals of different species. e.g., AABB, AABBDD. Bread wheat is allohexaploid (AABBDD). Triticale is the man-made cereal formed by hybridization between durum, wheat and rye. It is allohexaploid.
- **Autoallopolyploidy** : It is a kind of polyploidy where the genomes of two species come together in which one has double set of chromosomes. e.g., *Helianthus tuberosus* which is autoallohexaploid.
 - **Chromosomal aberrations** : These are the changes in morphology and structure of chromosome resulting in the change in number and sequence of genes on them without any change in ploidy. They are of the following types :
 1. **Deletion** : It is the loss of a terminal segment of a chromosome or from within the chromosome (interstitial segment) followed by a reunion of its remaining parts.
 2. **Inversion** : It is a change in a chromosome architecture due to breaking up, rotation through 180° of a segment and its reunion so that sequence of genes is reversed in the inverted region.
 3. **Duplication** : It is a change in chromosome structure in which a part of a chromosome breaks up and unites with another homologous chromosome. This process repeats the chromosome segments because the same block of genes is present more than once in a haploid component.
 4. **Translocation** : It is a change in chromosome architecture that is due to breaking up of segment of chromosome and its union with another non-homologous chromosome. It may also be due to mutual exchange of chromosomal segments between non-homologous chromosomes.

► Examples for Chromosomal Disorders

(a) Down's Syndrome (Mongolism) :

- It is the presence of an additional copy of chromosome number 21 (trisomy of 21).
- Genetic constitution : $45 A + XX$ or $45 A + XY$ (i.e., 47 chromosomes).
- **Features** :
 - (a) They are short-statured with small round head.
 - (b) Broad flat face.
 - (c) Furrowed big tongue and partially open mouth.
 - (d) Many "loops" on fingertips.
 - (e) Palm is broad with characteristic palm crease.
 - (f) Retarded physical, psychomotor & mental development.
 - (g) Congenital heart disease.



Key Fact

Punnett, Bateson and other workers found Mendel's work as an universal application, including animals also.

(b) Klinefelter's Syndrome :

- It is the presence of an additional copy of X-chromosome in male.
- Genetic constitution: $44 A + XXY$ (i.e., 47 chromosomes).
- **Features** :
 - (a) Overall masculine development however the feminine development is also expressed. e.g., development of breast (Gynaecomastia).
 - (b) Sterile.
 - (c) Mentally retarded.

(c) Turner's Syndrome :

- This is due to the absence of one of the X chromosomes in female.
- Genetic constitution: $44 A + XO$ (i.e., 45 chromosomes).
- **Features** :
 - (a) Sterile, Ovaries are rudimentary.
 - (b) Lack of other secondary sexual characters.
 - (c) Dwarf.
 - (d) Mentally retarded.



Mnemonics

Concept: Chromosomal Disorders

Mnemonics: Dying to know

Interpretations: Down's syndrome Turner's syndrome, Klinefelter's syndrome

CHAPTER-5

MOLECULAR BASIS OF INHERITANCE

Topic-1

Nucleic Acid – DNA and RNA

Concepts Covered • Nucleic acids, packaging of DNA helix, nucleosome, experiments to show DNA as a genetic material, RNA, process of protein synthesis.



Revision Notes

Genetic Material

► Nucleic Acids

- DNA and RNA are the two types of nucleic acids.
- DNA is the genetic material in all organisms except some viruses.
- RNA is the genetic material in some viruses.
- RNA mostly functions as messenger.

► Structure of Polynucleotide Chain

- Polynucleotides are the polymers of nucleotides.
- DNA and RNA are examples of polynucleotides.
- **A nucleotide has 3 components :**
 1. A nitrogenous base
 2. A pentose sugar (ribose in RNA and deoxyribose in DNA)
 3. A phosphate group
- Nitrogen bases are of 2 types :
 - (a) **Purines** : It includes Adenine (A) and Guanine (G).
 - (b) **Pyrimidines** : It includes Cytosine (C), Thymine (T) and Uracil (U). Thymine (5-methyl Uracil) present only in DNA and Uracil only in RNA (In place of thymine).
- A nitrogenous base is linked to the pentose sugar through an N-glycosidic linkage to form nucleoside.

Nucleosides in RNA	Nucleosides in DNA
Adenosine	Deoxyadenosine
Guanosine	Deoxyguanosine
Cytidine	Deoxycytidine
Uridine	Deoxythymidine

- Nitrogen base + sugar + phosphate group = Nucleotide (deoxyribonucleotide). In RNA, every nucleotide residue has an additional – OH group present at 2'-position in the ribose.
- 2 nucleotides are linked through 3' → 5' **phosphodiester** bond to form dinucleotide.
- When series of nucleotides are linked together, it forms polynucleotide.

► Structure of DNA

- **Johann Friedrich Miescher (1869)** : Identified DNA and named it as 'Nuclein'.
- **James Watson & Francis Crick** proposed the double helix model of DNA. It was based on the X-ray diffraction data produced by **Maurice Wilkins & Rosalind Franklin**.
- DNA is made of two polynucleotide chains coiled in a right-handed fashion. Its backbone is formed of sugar and phosphates. The bases project inside.
- The two chains have anti-parallel polarity i.e., one chain has the polarity 5' → 3' and the other has 3' → 5'.
- Nitrogen bases of opposite chains are held together by hydrogen bonds forming base pairs (bp).
- There are two hydrogen bonds between A and T (A = T) and three H-bonds between C and G (C ≡ G).
- Purine comes opposite to a pyrimidine. This generates a uniform distance between the two strands.

► Erwin Chargaff's Rule

- Purines and pyrimidines are always in equal amounts i.e., A + G = T + C.
- In DNA, the proportion of A is equal to T and the proportion of G is equal to C i.e., A = T and G = C.
- The base ratio A + T/G + C may vary from species to species but constant for a given species.
- Length of DNA = number of base pairs × distance between two adjacent base pairs.

- ϕ 174 (a bacteriophage) has 5386 nucleotides.
- Bacteriophage lambda has 48502 base pairs (bp).
- *E. coli* has 4.6×10^6 bp.
- Haploid content of human DNA = 3.3×10^9 bp.
- Number of base pairs in human = 6.6×10^9
- Length of DNA in humans = 6.6×10^9 bp $\times 0.34 \times 10^{-9}$ m/bp = 2.2 m
- Length of DNA in *E. coli* = 1.36 mm (1.36×10^{-3} m).
- ∴ The number of base pairs = 1.36×10^{-3} m / 0.34×10^{-9} m/bp = 4×10^6 bp.

► Packaging of DNA Helix

- In prokaryotes (e.g., *E. coli*), the DNA molecule is held with some positively charged non-histone basic proteins like negatively charged polyamines and form 'nucleoid'.
- In eukaryotes, there is a set of positively charged basic proteins called histones.
- Histone proteins are rich in positively charged basic amino acid residues lysine and arginine.
- There are five types of histone proteins-H1, H2A, H2B, H3 and H4.
- Two molecules each of H2A, H2B, H3 and H4 organize to form a unit of eight molecules called as histone octamer.
- Negatively charged DNA is wrapped around positively charged histone octamer to form a structure called a nucleosome.
- Nucleosomes are connected with the help of linker DNA on which H1 Histone is present.

► Nucleosome

- A typical nucleosome contains 200 bp of DNA helix.
- Therefore, the total number of nucleosomes in human = 6.6×10^9 bp / 200 bp = 3.3×10^7 .
- Nucleosomes constitute the repeated unit to form chromatin.
- Chromatin is the thread-like stained bodies.
- Nucleosomes in chromatin appears as "beads-on-string" when it is viewed under the electron microscope.
- Chromatin is packaged to form a solenoid or a zig-zag structure.
- Further supercoiling constitute a looped structure called chromatin fibre.
- These chromatin fibres further coil and condense at the metaphase stage of cell division to form chromosomes.
- Chromatin is packaged → solenoid → chromatin fibres → coiled and condensed at metaphase stage → chromosomes.
- Higher level packaging of chromatin requires non-histone chromosomal (NHC) proteins.
- Two types of chromatin are :
 - (a) **Euchromatin** : Loosely packed and transcriptionally active chromatin and is light-stained.
 - (b) **Heterochromatin** : Densely packed and inactive region of chromatin and stains dark.



Key Facts

In Eukaryotes, DNA polymerases are of 5 types, these are DNA polymerase α , β , γ , δ and ϵ .

Nucleotide arrangement in DNA can be seen by X-ray Crystallography.

Example 1

Q. Calculate the number of beaded structures (nucleosomes) present in the nucleus of diploid eukaryotic cell which possess 2.2×10^6 bp.

Sol. One nucleosome has 200 bp.
The number of beaded structures (nucleosomes)

present in the nucleus of diploid eukaryotic cell which possess 2.2×10^6 bp.

$$\therefore \frac{2.2 \times 10^6}{200} = 1.1 \times 10^4 \text{ or } 11 \times 10^3 \text{ nucleosomes}$$

► The Search for Genetic Material

Griffith's Experiment - Transforming Principle

- **Griffith** (1928) used mice and a bacterial strain, *Streptococcus pneumoniae*.
- *Streptococcus pneumoniae* has two strains :
 - (a) **Smooth (S) strain (Virulent)** : Has polysaccharide mucous coat. Causes pneumonia.
 - (b) **Rough (R) strain (Non-virulent)** : No mucous coat. Does not cause pneumonia.

► Experiment

- S-strain → Inject into mice → Mice die
- R-strain → Inject into mice → Mice live
- S-strain (Hk) → Inject into mice → Mice live
- S-strain (Hk) + R-strain (live) → Inject into mice → Mice die
- He concluded that there exists some 'transforming principle', that is transferred from heat-killed S-strain to R-strain. It enabled R-strain to synthesize smooth polysaccharide coat and become virulent. This must be due to the transfer of genetic material.

► Biochemical Characterization of Transforming Principle

- Oswald Avery, Colin MacLeod & Maclyn McCarty in 1944 worked to determine the biochemical nature of 'transforming principle' in Griffith's experiment.
- They purified biochemicals (proteins, DNA, RNA, etc.) from heat-killed S cells using suitable enzymes.
- They discovered that :
 - (a) Digestion of protein and RNA (using Proteases and RNases) did not affect transformation. So, the transforming substance was not a protein or RNA.
 - (b) Digestion of DNA with DNase inhibited transformation. It means that DNA caused the transformation of R cells to S cells i.e., DNA was the transforming substance.

► The Genetic Material is DNA

- The fact that DNA is the genetic material also came from the experiments of **Alfred Hershey** and **Martha Chase (1952)**.
- They worked with viruses that infect bacteria and are called bacteriophages.

► Hershey-Chase Experiment—Blender Experiment

- Hershey and Chase made two preparations of bacteriophage - In one, proteins were labelled with ^{35}S by putting in a medium containing radioactive sulphur (^{35}S). In the second, DNA was labelled with ^{32}P by putting in a medium containing radioactive Phosphorous (^{32}P).
- These preparations were used separately to infect *E. coli*.
- After infection, the *E. coli* cells were gently agitated in a blender to separate the phage particles from the bacteria.
- Then the culture was centrifuged. Heavier bacterial cells were formed as a pellet at the bottom. Lighter viral components outside the bacterial cells remained in the supernatant.
- They found that,
 - (a) Supernatant contains viral protein labelled with ^{35}S , i.e., the viral protein had not entered the bacterial cells.
 - (b) The bacterial pellet contains radioactive ^{32}P . This shows that viral DNA labelled with ^{32}P had entered the bacterial cells. This proves that DNA is the genetic material.

► Properties of Genetic Material

- A molecule that can act as a genetic material must fulfill the following criteria :
 - (a) Be able to generate its replica by the process of replication.
 - (b) Chemically and structurally be stable.
 - (c) Allow slow changes, the mutations that are required for evolution.
 - (d) It should be able to store genetic information which can be inherited.
 - (e) Be able to express itself as 'Mendelian Characters'.



Key Words

Euchromatin : The region of chromatin which is loosely packed and genetically active.

Heterochromatin : The chromatin that is more densely packed, stains dark and is genetically inactive.

► DNA is a better Genetic Material than RNA due to the following reasons :

- DNA is chemically less reactive and structurally more stable. It can undergo repair.
- Due to the unstable nature of RNA, RNA viruses (e.g., Q β bacteriophage, Tobacco Mosaic Virus, etc.) mutate and evolve faster.
- For the storage of genetic information, DNA is better due to its stability. But for the transmission of genetic information, RNA is better.
- RNA can directly code for protein synthesis, hence can easily express the characters. DNA is dependent on RNA for protein synthesis.

Reasons for stability (less reactivity) of DNA	Reasons for mutability (high reactivity) of RNA
Double-stranded	Single-stranded
Presence of thymine	Presence of Uracil
Absence of 2'-OH	Presence of 2'-OH

- The two DNA strands are complementary. On heating, they separate. When appropriate conditions are provided they come together. (In Griffith's experiment, when the bacteria were heat-killed, some properties of DNA did not destroy).

► RNA World

- RNA is a single-stranded structure but it is often folded back upon itself forming helices. Nitrogenous bases are like those of DNA except that there is **uracil** in place of **thymine**.

- RNA was the first regulatory chemical and genetic material in early life forms.
- It acts as genetic material and biocatalyst.
- Essential life processes (metabolism, translation, splicing, etc) evolved around RNA.
- DNA has evolved from RNA with chemical modifications that made it more stable.

▶ Central Dogma of Molecular Biology

- It was proposed by **Francis Crick** (1958). It states that the genetic information flows unidirectionally from DNA → RNA → Protein.

▶ Reverse Transcription : H. Temin and Baltimore in 1978 gave the concept of reverse flow of genetic information i.e., the formation of DNA from RNA. This is called Reverse Central Dogma or Teminism or reverse transcription. This takes place in some of the viruses in the presence of an enzyme called reverse transcriptase.

▶ Types of RNA

- RNA is of 3 types –mRNA, tRNA and rRNA.
- mRNA constitutes 2–5% of the total cellular RNA, tRNA is about 15% and rRNA is about 70–80%.
- **mRNA (messenger RNA)** : Provides a template for translation (protein synthesis) and is transcribed from DNA.
- **rRNA (ribosomal RNA)** : Structural and catalytic role during translation. e.g., ²³S rRNA in bacteria acts as ribozyme.
It is the component of ribosome and is the most stable type of RNA.
- **tRNA (transfer RNA or sRNA or soluble RNA or adaptor RNA)** : Brings amino acids for protein synthesis and reads the genetic code.
- tRNA is the smallest amongst all the RNA and is made up of 70–80 nucleotides only.

▶ DNA Replication

- Replication is the copying of DNA from parental DNA.
- **Watson & Crick** proposed a semi-conservative mode of replication.
- It suggests that the parental DNA strands act as a template for the synthesis of new complementary strands. After the completion of replication, each DNA molecule would have one parental and one new strand.

▶ Experimental Proof

- **Mathew Meselson & Franklin Stahl (1958)** experimentally proved semi-conservative mode.
- **Meselson & Stahl's Experiment** : They cultured *E. coli* in a medium containing N¹⁵H₄Cl (N¹⁵ : heavy isotope of N). N¹⁵ was incorporated into both strands of bacterial DNA and the DNA became heavier.
- Another preparation containing N salts labelled with N¹⁴ was also made. N¹⁴ was also incorporated in both strands of DNA and became lighter.
- These two types of DNA can be separated by centrifugation in a CsCl density gradient.
- They took *E. coli* cells from the N¹⁵ medium and transferred them to the N¹⁴ medium.
- After one generation (i.e., after 20 minutes), they isolated and centrifuged the DNA. Its density was intermediate (hybrid) between ¹⁵N DNA and ¹⁴N DNA. This showed that in the newly formed DNA, one strand is old (N¹⁵ type) and one strand is new (N¹⁴ type). This confirms the semi-conservative mode of replication.
- After II generations (i.e., after 40 minutes), there were equal amounts of hybrid DNA and light DNA.
- **Taylor et. al (1958)** performed similar experiments on *Vicia faba* (faba beans) using radioactive thymidine to detect distribution of newly synthesized DNA in the chromosomes. It proved that the DNA in chromosomes also replicate semi-conservatively.

▶ The Machinery and Enzymes for Replication

- DNA replication starts at a point called *origin (ori)*.
- A unit of replication with one origin is called a *replicon*.
- During replication, the two strands unwind and separate by breaking H-bonds in the presence of an enzyme, Helicase.
- Unwinding of the DNA molecule at a point forms a 'Y'-shaped structure called replication fork.
- The separated strands act as templates for the synthesis of new strands.
- DNA replicates in the 5'→3' direction.
- Deoxyribonucleoside triphosphates (dATP, dGTP, dCTP & dTTP) act as substrate and also provide energy for polymerization.
- Firstly, a small RNA primer is synthesized in presence of an enzyme, primase.
- In the presence of an enzyme, DNA dependent *DNA polymerase*, many nucleotides join with one another to primer strand and form a polynucleotide chain (new strand).
- The DNA polymerase forms one new strand (leading strand) on a continuous stretch in the 3'→5' direction (Continuous synthesis).
- The other new strand is formed in small stretches (Okazaki fragments) in the 5'→3' direction (Discontinuous synthesis).
- The Okazaki fragments are then joined together to form a new strand by an enzyme, DNA ligase. This new strand is called lagging strand.
- If a wrong base is introduced in the new strand, DNA polymerase can do proofreading.
- *E. coli* completes replication within 38 minutes i.e., 2000 bp per second.
- In eukaryotes, the replication of DNA takes place at the S-phase of the cell cycle. Failure in cell division after DNA replication results in polyploidy.

► Transcription

- It is the process of copying genetic information from one strand of the DNA into RNA.
- Here, adenine pairs with uracil instead of thymine.
- Both strands are not copied during transcription, because
 - (a) The code for protein is different in both strands. This complicates the translation.
 - (b) If two RNA molecules are produced simultaneously they would be complementary to each other, hence form a double-stranded RNA. This prevents translation.

► Transcription Unit

- It is the segment of DNA between the sites of initiation and termination of transcription.
- It consists of 3 regions :
 - (a) **A promoter (Transcription start site)** : Binding site for RNA polymerase.
 - (b) **Structural gene** : The region between promoter and terminator where transcription takes place.
 - (c) **A terminator** : The site where transcription stops.
- The DNA- dependent RNA polymerase catalyses the polymerization only in 5'→3' direction.
- 3'→5' acts as the template strand. 5'→3' acts as the coding strand.
- 3'-ATGCATGCATGCATGCATGC-5' template strand.
5'-TACGTACGTACGTACGTACGTACG-3' coding strand.

► Transcription Unit and the Gene

- **Gene** : Functional unit of inheritance. It is the DNA sequence coding for RNA molecule.
- **Cistron** : A segment of DNA coding for a polypeptide.
- Structural gene in a transcription unit is of two types :
 - (a) **Monocistronic structural genes (split genes)** : It is seen in eukaryotes. Here, the coding sequences (expressed sequences or exons) are interrupted by introns (intervening sequences).
 - (b) **Polycistronic structural genes** : It is seen in prokaryotes. Here, there are no split genes.
- **Exons and Introns** : In eukaryotes, the monocistronic structural genes have interrupted coding sequences i.e., the genes in eukaryotes are split. The coding sequences or expressed sequences are called as exons. Exons are said to be those sequences that appear in mature or processed RNA. The exons are interrupted by introns. Introns or intervening sequences do not appear in mature or processed RNA.

► Steps of transcription in prokaryotes

- **Initiation** : Here, the enzyme RNA polymerase binds at the promoter site of DNA. This causes the local unwinding of the DNA double helix. An initiation factor (σ factor) present in RNA polymerase initiates the RNA synthesis.
- **Elongation** : The RNA chain is synthesized in the 5'-3' direction. In this process, activated ribonucleoside triphosphates (ATP, GTP, UTP & CTP) are added. This is complementary to the base sequence in the DNA template.
- **Termination** : A termination factor (ρ factor) binds to the RNA polymerase and terminates the transcription.
- In bacteria (Prokaryotes), transcription and translation can be coupled (Translation can begin before mRNA is fully transcribed) because mRNA requires no processing to become active.
- Transcription and translation take place in the same compartment (no separation of cytosol and nucleus).



Key Words

Introns : The regions of a gene which are removed during the processing of mRNA.

Exons : The regions of a gene which become part of mRNA and code for different regions of proteins.

► In eukaryotes, there are 2 additional complexities :

- (a) **There are three RNA polymerases** :
 - **RNA polymerase I** : Transcribes rRNAs (28S, 18S & 5.8S).
 - **RNA polymerase II** : Transcribes the heterogeneous nuclear RNA (hnRNA). It is the precursor of mRNA.
 - **RNA polymerase III** : Transcribes tRNA, 5S rRNA and snRNAs (small nuclear RNAs).
- (b) **The primary transcripts (hnRNA)** : They contain both the exons and introns and are non-functional. Hence introns have to be removed. For this, it undergoes the following processes :
 - **Splicing** : From hnRNA, introns are removed (by the spliceosome) and exons are spliced (joined) together.
 - **Capping** : Here, a nucleotide methyl guanosine triphosphate (cap) is added to the 5' end of hnRNA.
 - **Tailing (Polyadenylation)** : Here, adenylate residues (200-300) are added at 3'-end. It is the fully processed hnRNA, now called mRNA.



Mnemonics

1. Concept: Erwin Chargaff's Rule

Mnemonics: AayaTha; ChalaGya

Interpretations: A- Adenine = T- Thymine

G-Guanine = C- Cytosine

2. Concept: Central Dogma of Molecular Biology

Mnemonics: Doctors Recovered Patients

Interpretations: DNA \rightleftharpoons RNA \rightarrow Protein

IMPORTANT DIAGRAMS :

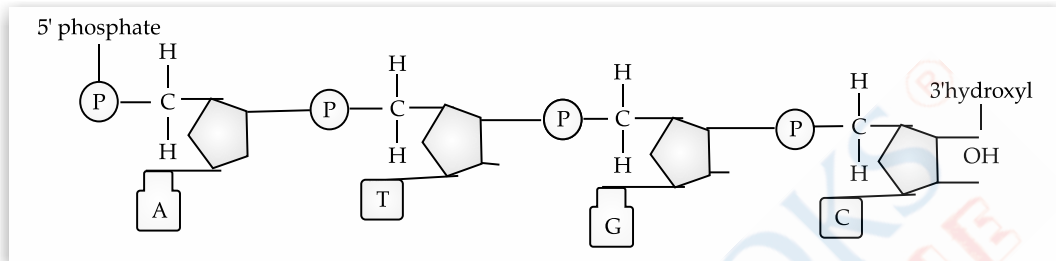

Fig 5.1 : A polynucleotide Chain of RNA

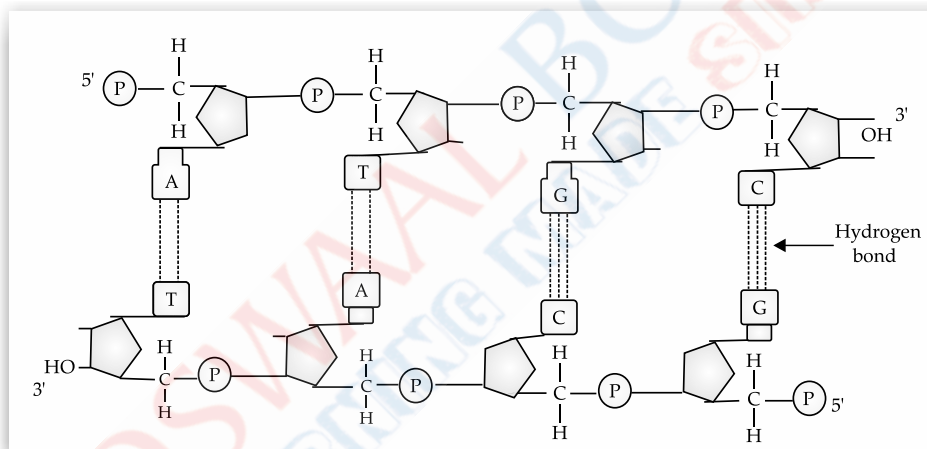

Fig 5.2 : Double Stranded polynucleotide chain

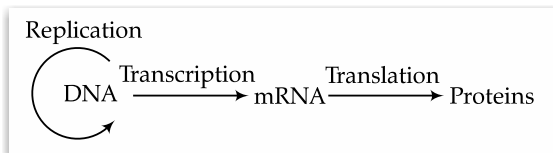

Fig 5.3 : Central Dogma

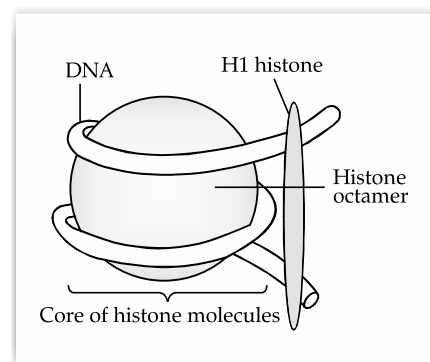

Fig 5.4 : Nucleosome

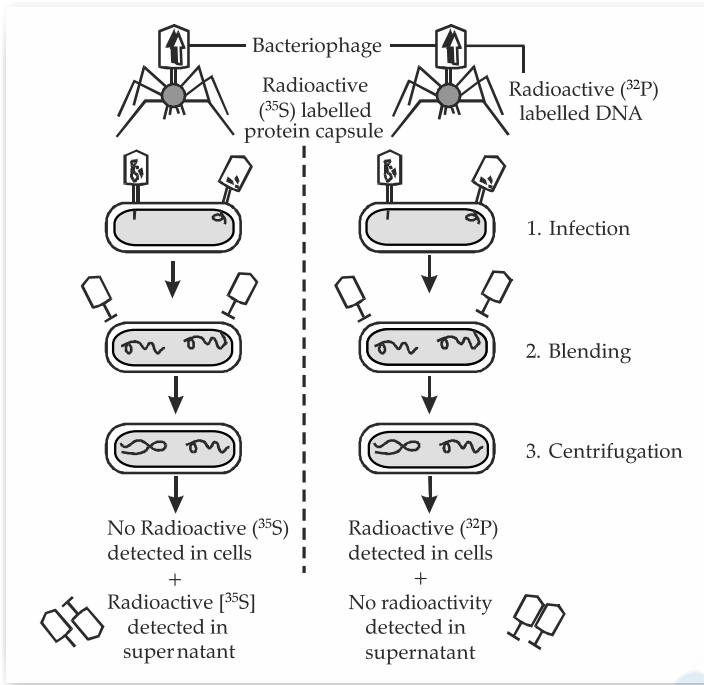

Fig 5.5 : The Hershey and Chase Experiment

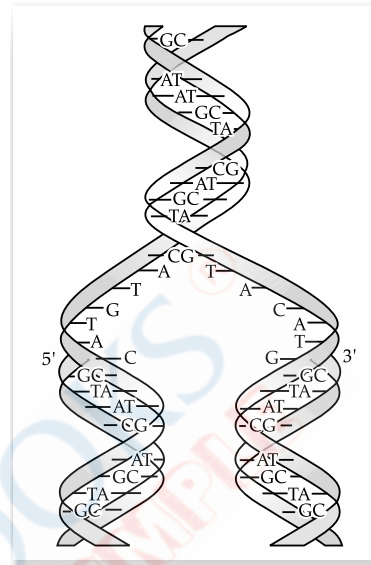

Fig 5.6 : Watson Crick model of Semi-conservative DNA replication

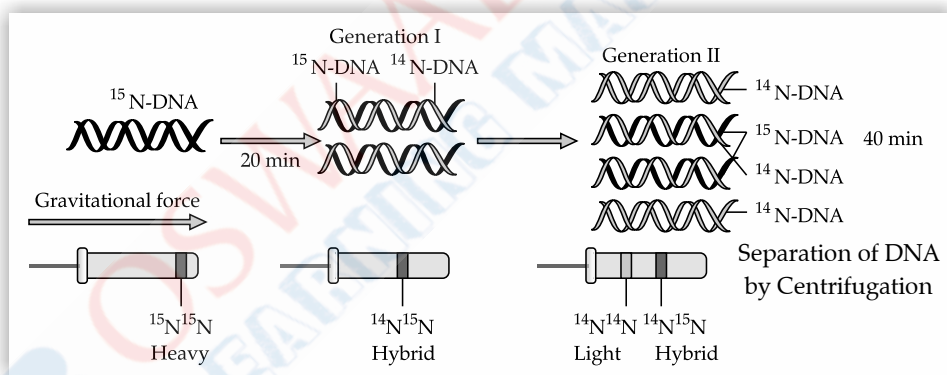

Fig. 5.7 : Meselson and Stahl's Experiment

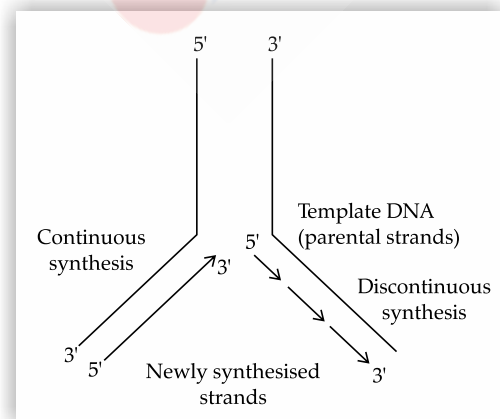

Fig 5.8 : Replicating Fork

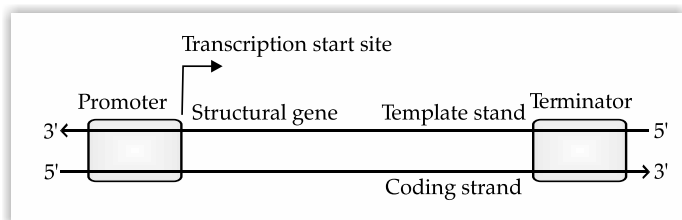

Fig 5.9 : Schematic structure of a transcription unit

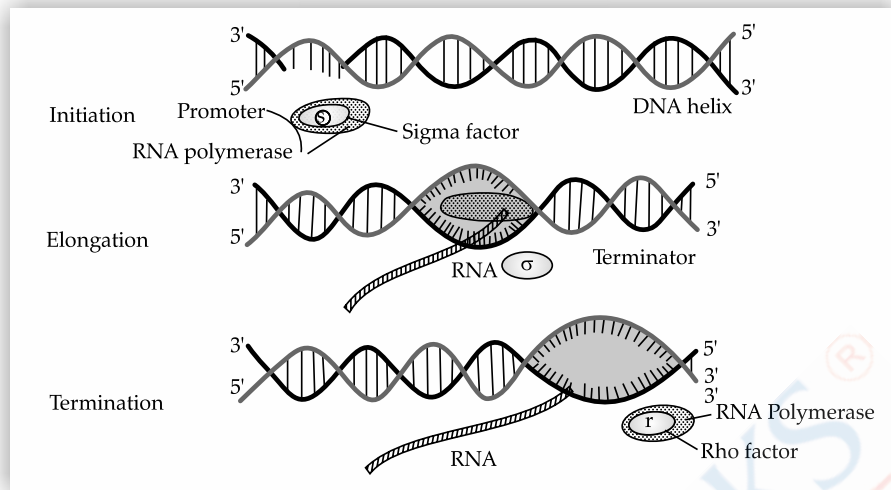

Fig 5.10 : Process of Transcription in Bacteria

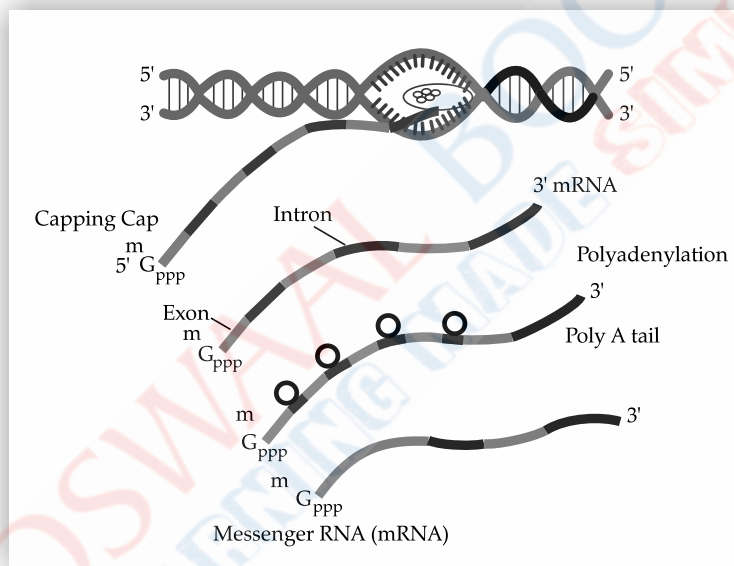

Fig 5.11 : Process of Transcription in Eukaryotes

Topic-2

Genetic Code, Translation, Lac Operon, HGP and DNA Fingerprinting

Concepts Covered • Genetic code, Translation, Gene expression, Lac Operon, HGP, Rice Genome Project, steps and application of DNA Fingerprinting



Revision Notes

- **Genetic Code** : It is the sequence of nucleotides in mRNA that contains information for protein synthesis (translation).
- 20 amino acids are involved in translation.
 - **George Gamow** : Suggested that for coding 20 amino acids, the code should be made up of 3 consecutive nucleotides.
 - **Har Gobind Khorana** : Developed the chemical method in synthesizing RNA molecules with defined combinations of bases (homopolymers and copolymers).
 - **Marshall Nirenberg** : Developed a cell-free system for protein synthesis.

- *Severo Ochoa* (polynucleotide phosphorylase) enzyme is used to polymerize RNA with defined sequences in a template-independent manner.

► Salient Features of Genetic Code

- The genetic code is a triplet code (three-letter code) where three adjacent nitrogen bases code for a single amino acid.
- 61 **codons** code for amino acids. 3 codons (UAA, UAG and UGA) do not code for any amino acids. They function as stop codons (Termination codons or non-sense codons).
- Genetic code is universal e.g., From bacteria to human UUU codes for Phenylalanine. Some exceptions are found in mitochondrial codons and in some protozoans.
- No punctuations between adjacent codons (comma less code). The codon is read in mRNA in a continuous fashion.
- Genetic code is non-overlapping.
- A single amino acid is represented by many codons (except AUG for methionine and UGG for tryptophan). Such codons are called degenerate codons.
- Genetic code is unambiguous and specific. i.e., one codon specifies for only one amino acid.
- The codon is read in the 5' → 3' direction.
- AUG has dual functions. It codes for Methionine (met) and also acts as an initiator codon. In eukaryotes, methionine is the first amino acid and formyl methionine is the first amino acid in prokaryotes.



Key Facts

- RNA was the first genetic material to evolve and DNA was derived from it.
- DNA polymerase can not start DNA synthesis i.e., Denovo synthesis.
- RNA polymerase can start Denovo synthesis

► Mutations and Genetic Code

- The relationships between genes and DNA are best understood by mutation studies.
- Effects of large deletions and rearrangements in a segment of DNA may result in loss or gain of a gene and so a function.
- A classical example of point mutation is a change of single base pair in the gene for beta globin chain of haemoglobin that results in the change of amino acid residue glutamate to valine. It results into a diseased condition called sickle cell anaemia.
- Insertion or deletion of one or two bases changes the reading frame from the point of insertion or deletion.
- When there is shifting of the reading frame due to insertion or deletion of the nucleotide, such mutation is known as **frameshift mutation**.
- This forms the genetic basis of proof that the codon is a triplet and is read in a continuous manner.

► The Adaptor Molecule – tRNA

- The tRNA is a molecule that has about 60% of its part double-stranded and the rest remains single stranded which has unpaired bases.
- The tRNA has
 - (a) An **anticodon** (NODOC) loop that has bases complementary to the CODON with which it gets attached in mRNA.
 - (b) An amino acid acceptor end to which amino acid binds. This end or site lies at the 3' end & CCA-OH group. The 5' end bears G.
 - (c) **T Ψ C loop** : This is the site for attaching with the ribosome. This has some unusual bases like Ψ (pseudouridine) and ribothymidine.
 - (d) **DHU-Loop** : It is the binding site for the enzyme aminoacyl synthetase. It is the largest loop and has Dihydrouridine.
 - (e) **Extra arm** : It is a variable side arm lying between T Ψ C and anticodon loop.
- tRNA is called an adaptor molecule because it picks up amino acids from the cytoplasm and transfers them to ribosomes during protein synthesis.
- For initiation, there is another tRNA called initiator tRNA.
- There are no tRNAs for stop codons.
- 2-D structure of tRNA looks like a **clover-leaf** according to Robert Holly (1965). The 3-D structure looks like inverted 'L' according to Klug (1974).



Key Words

Anticodon : A sequence of three nitrogenous bases on tRNA which is complementary to the codon on mRNA.

Codon : A Sequence of three nucleotides present on mRNA which encodes for specific amino acid during translation.

► Translation – Protein Synthesis

It takes place in ribosomes. It includes 4 steps :

1. Charging of tRNA (aminoacylation of tRNA)

- Formation of a peptide bond requires energy obtained from ATP.
- For this, amino acids are activated (amino acid + ATP) and linked to their cognate tRNA in the presence of aminoacyl tRNA synthetase. So, the tRNA becomes charged.

2. Initiation

- It begins at the 5'-end of mRNA in the presence of an initiation factor.
- The mRNA binds to the small subunit of the ribosome. Now the large subunit binds to the small subunit to complete the initiation complex.
- Large subunit has 2 binding sites for tRNA- aminoacyl tRNA binding site (A site) and peptidyl site (P site).
- Initiation codon for methionine is AUG. So, methionyl tRNA complex would have UAC at the anticodon site.

3. Elongation

- At the P-site the first codon of mRNA binds with anticodon of methionyl tRNA complex.
- Another aminoacyl tRNA complex with an appropriate amino acid enters the ribosome and attaches to A site.
- Its anticodon binds to the second codon on the mRNA and a peptide bond is formed between first and second amino acids in presence of an enzyme, peptidyl transferase.
- The uncharged tRNA moves from the P site to the E site and the peptidyl-tRNA moves to the P site. This is called a translocation.
- Then 3rd codon comes into A site and a suitable tRNA with 3rd amino acid binds at the A site. This process is repeated.
- A group of ribosomes associated with a single mRNA for translation is called a polyribosome (polysomes).
- A ribozyme is a ribonucleic acid (RNA) enzyme that catalyses a chemical reaction. The ribozyme catalyses specific reactions in a similar way to that of protein synthesis. Also called catalytic RNA, ribozyme are found in ribosome where they join amino acids together to form protein chains.

4. Termination

- When aminoacyl tRNA reaches the termination codon like UAA, UAG & UGA, the termination of translation occurs. The polypeptide and tRNA are released from the ribosomes.
 - The ribosome dissociates into large and small subunits at the end of protein synthesis.
- An mRNA has additional sequences that are not translated (untranslated regions or UTR). UTRs are present at both 5'-end (before start codon) and 3'-end (after stop codon). They are required for an efficient translation process.



Mnemonics

Concept : Translation process (It include 4 steps)

Mnemonics : Come In Evening Time

Interpretations : Charging of tRNA, Initiation, Elongation, Termination

► Regulation of Gene Expression

Gene expression results in the formation of a polypeptide. In eukaryotes, the regulation includes the following levels :

- Transcriptional level (formation of primary transcript).
- Processing level (regulation of splicing).
- Transport of mRNA from the nucleus to the cytoplasm.
- Translational level.

► Importance of regulation of gene expression:

- Gene regulation is the process to switch off or switch on the genes as per the requirement of the organism.
- Gene regulation is required so that there is no waste of energy in expressing the genes not required at the time.
- However, there are housekeeping genes that are always expressed in the cell.

The metabolic, physiological and environmental conditions regulate the expression of genes. e.g.,

- In *E. coli*, the enzyme beta-galactosidase hydrolyses lactose into galactose and glucose. In the absence of lactose, the synthesis of beta-galactosidase stops.
- The development and differentiation of an embryo into an adult the result of the regulation of several set of genes.

► **Operon Concept :** This is a regulatory system that is observed in bacteria.

- "Each metabolic reaction is controlled by a set of genes".

- All the genes regulating a metabolic reaction constitute an *Operon* e.g., *lac* operon, *trp* operon, *ara* operon, *his* operon, *val* operon etc.
- When a substrate is added to growth medium of bacteria, a set of genes is switched on to metabolize it. This is called induction.
- When a metabolite (product) is added, the genes to produce it are turned off. This is called repression.

► The Lac Operon

- **Lac operon in *E. coli*** : The operon controlling lactose metabolism. It consists of a regulator gene, 3-structural genes, an operator gene, promoter gene, a repressor and an inducer.
 - (a) **A regulatory or inhibitor gene** : Codes for the repressor.
 - (b) **3 structural genes** :
 - (i) **z gene** : Codes for β -galactosidase (hydrolyze lactose to galactose and glucose).
 - (ii) **y gene** : Codes for permease (increase permeability of the cell to lactose).
 - (iii) **a gene** : Codes for a transacetylase.



Key Word

Operon : A group of genes which control a metabolic pathway.

- The genes present in the operon function together in the same or related metabolic pathway. There is an operator region for each operon.
- If there is no lactose (inducer), *lac* operon remains switched off. In the absence of inducer, repressor gene is active. The regulator gene synthesizes mRNA to produce the repressor protein, this protein binds to the operator genes and blocks RNA polymerase movement. So, the structural genes are not expressed.
- In the absence of glucose, If lactose is provided in the growth medium, the lactose is transported into the *E. coli* cells by the action of permease. Lactose (inducer) binds with repressor protein.
- So, repressor protein cannot bind to operator gene. The operator gene becomes free and induces the RNA polymerase to bind with promoter gene then transcription starts. Regulation of *lac* operon by repressor is called negative regulation.

► Human Genome Project (HGP)

- The entire DNA in the haploid set of chromosome of an organism is called a Genome.
- In human genome, DNA is packed in 23 chromosomes.
- Human Genome Project (1990-2003) is the first effort in identifying the sequence of nucleotides and mapping of all the genes in the human genome.
- Human genome contains about 3×10^9 bp.

► Goals of HGP

- (a) To identify all the estimated genes in human DNA.
- (b) To determine the sequences of the 3 billion chemical base pairs that make up human DNA.
- (c) To store this information in databases.
- (d) To improve tools for data analysis.
- (e) To transfer related technologies developed during the project of society to other sectors of society.
- (f) To address the ethical, legal and social issues (**ELSI**) that may arise from the project.

► HGP was Closely Associated with Bioinformatics

The application of computer science and information technology to the field of biology and medicine helps in analysing DNA sequence data.

► Methodologies of HGP

There are two major approaches namely, ESTs and sequence annotation.

- **Expressed Sequence Tags (ESTs)** : Focused on identifying all the genes that are expressed as RNA and sequencing the same.
- **Sequence annotation** : Sequencing whole set of the genome containing all the coding & non-coding regions and later assigning functions to different regions.

► Procedure :

Isolate total DNA from a cell → Convert into random fragments of smaller size → Clone in suitable host (e.g., BAC – bacterial artificial chromosomes & YAC – yeast artificial chromosomes) for amplification through PCR (polymerase chain reaction) → Fragments are sequenced using Automated DNA sequencers (using Frederick Sanger method) → Sequences are arranged based of the overlapping regions → Alignment of sequences using computer-based programs → Genetic and physical maps on the genome were generated using the information on polymorphism of restriction endonuclease recognition sites and some repetitive DNA sequences (micro-satellites).

► Salient Features of Human Genome

- (a) Human genome contains 3164.7 million nucleotide bases pairs.

- (b) Total number of genes = about 25,000.
- (c) Average gene consists of 3000 bases, but sizes vary. The largest known human gene (dystrophin on X-chromosome) contains 2.4 million bases.
- (d) 99.9% of nucleotide bases are identical in all people. It is 0.1% which makes each of us unique.
- (e) Functions of over 50% of discovered genes are unknown.
- (f) Chromosome I has the most genes (2968) and Y has the fewest (231).
- (g) Less than 2% of the genome codes for proteins.
- (h) Repeated sequences make up a very large portion of the human genome. Repetitive sequences are stretches of DNA sequences that are repeated many times. They have no direct coding functions but they shed light on chromosome structure, dynamics and evolution.
- (i) About 1.4 million locations where single-base DNA differences (SNPs- Single nucleotide polymorphism or 'snips') occur in humans.

► Rice Genome Project

Rice is one of the most largely consumed foods in India. Also, the population is increasing with a rapid pace, so, to meet this requirement, Rice genome project has been launched to increase the production of rice. Rice has the smallest genome of 430Mb nucleotides located on chromosome 12.

► Rice Genome : It is a joint project of National Institute of Aerobiological Sciences (NIAS), forestry and fisheries (STAFF), Ministry of Agriculture, Forestry and Fisheries (NAFF), Society for Techno-innovation of Agriculture genome research program.

Arabidopsis is an experiment plant of rice genome because it has fast life cycle and can be easily grown. It has smaller genome and high diversity and helps in enhancing the molecular products.



Key Word

ESLI : Ethical, legal and social implications of genetic and genomic research.

Need for sequencing rice genome:

- To know the functioning of genes by accurate gene sequencing.
- It is important for agronomic traits which requires mapping of genomic sequences.
- Improvement of other cereals will become easier.

► DNA Fingerprinting (DNA profiling)

- It is the technique to compare the DNA fragments of two individuals.
- Developed by **Alec Jeffreys (1985)**. He is considered as the father of DNA fingerprinting. **Lalji Singh** is the Father of Indian DNA fingerprinting.

► Basis of DNA Fingerprinting

- DNA carries some non-coding sequences called repetitive sequence [Variable Number of Tandem Repeats (**VNTR**)].
- Number of repeats is specific. It varies from person to person and is specific to a person.
- The size of VNTR varies from 0.1 to 20 kb.
- Repetitive DNA is separated from bulk genomic DNA as different peaks during density gradient centrifugation.
- The bulk DNA forms a major peak and the other small peaks are called satellite DNA.
- Satellite DNA is classified into many categories (micro-satellites, mini-satellites, etc.) based on the base composition (A-T rich or G-C rich), length of segment and number of repetitive units.
- An inheritable mutation observed in a population at high frequency is called DNA polymorphism (variation at genetic level).
- Polymorphism is higher in non-coding DNA sequence. This is because mutations in these sequences may not have any immediate effect on an individual's reproductive ability.
- These mutations accumulate generation after generation and cause polymorphism. For evolution & speciation, polymorphisms play an important role.

► Steps of DNA Fingerprinting (Southern Blotting Technique)

- (a) Isolate DNA (from any cells like blood stains, semen stains or hair roots).
- (b) Make copies (amplification) of DNA by Polymerase Chain Reaction (PCR) if the amount of isolated DNA is small.
- (c) Digest DNA by restriction endonucleases.
- (d) Separate DNA fragments by gel electrophoresis over agarose polymer gel.
- (e) Treat with alkali solution (NaOH) to denature DNA bonds so as to split them into single-stranded DNAs in the gel.
- (f) Transfer (blotting) single-stranded DNA fragments to synthetic membranes such as nitrocellulose or nylon, and then baked in a vacuum oven at 80°C for 3-5 hours (to fix the DNA fragment on the membrane).
- (g) Nitrocellulose filter membrane is placed in a solution containing a radioactive labelled single-stranded DNA probe. The DNA probes are small radioactive synthetic DNA segments of known sequences of nitrogen bases. These DNA probe binds with the complementary sequences of the DNA fragment on the membrane to form a hybridized DNA.
- (h) The filter paper is washed to remove unbound probe.

(i) The hybridised DNA is photographed on to an X-ray film by autoradiography. The image (in the form of dark & light bands) obtained is called a DNA fingerprint. This gives the characteristic pattern of an individual's DNA.

► **Applications of DNA Fingerprinting are :**

- Forensic tool to solve paternity, rape, murder, etc.
- For the diagnosis of genetic diseases.
- To determine the phylogenetic status of animals.



Key Word

VNTR: Variable Number of Tandem Repeats



Key Fact

► DNA finger printing is based upon principle of polymorphism in DNA sequence.

IMPORTANT DIAGRAMS :

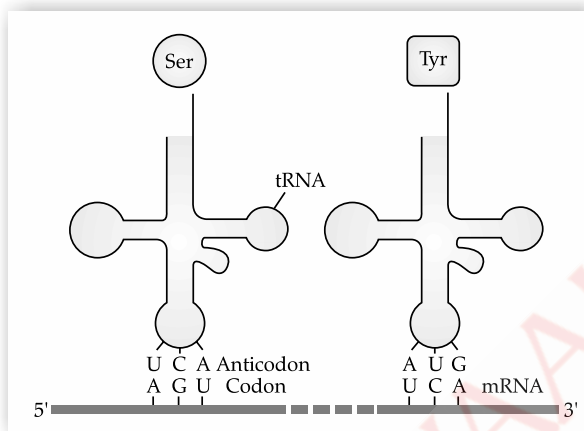

Fig 5.12: tRNA- the adapter molecule

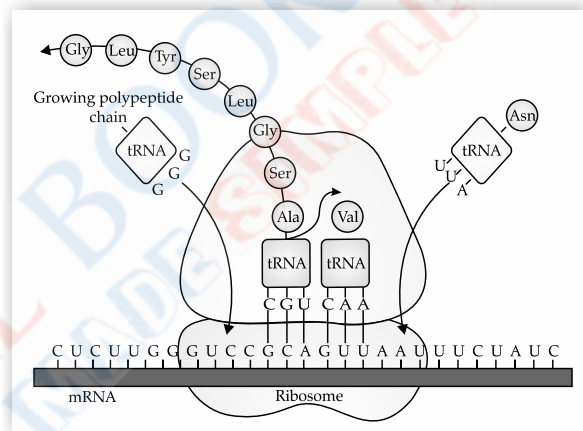

Fig 5.13: Translation

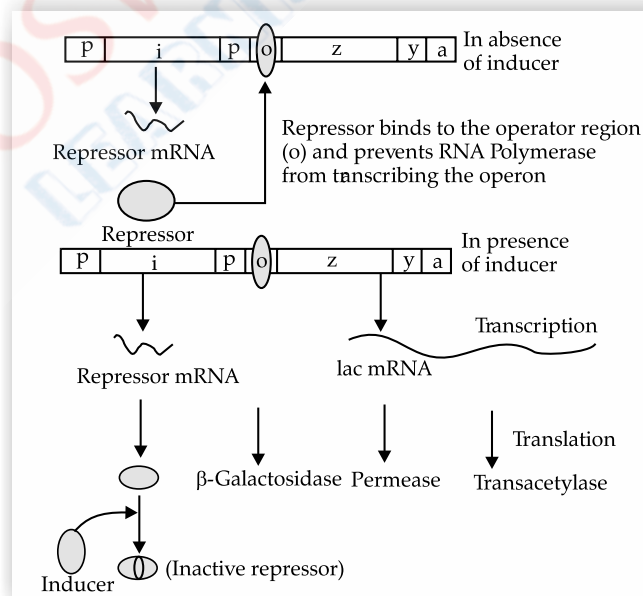

Fig 5.14: The lac Operon

Example 2

Q. When does lac operon get switched off ?

Sol. The lac operon comprises of one regulatory gene or inhibitor gene (i), one promoter gene, one operator gene and three structural genes. Regulator gene codes for a protein known as repressor protein, it is synthesised all the time from the i-gene.

The operon gets switched off when repressor protein produced by regulatory or inhibitor gene binds to operation gene. RNA polymerase gets blocked, so there is no transcription.

Repressor protein + Operator gene → Switched off

CHAPTER-6

EVOLUTION

Topic-1

Origin of Life on Earth and Various Related Evidences

Concepts Covered • Theories of origin of life, Urey-Miller experiment Evolution and it's evidences.



Revision Notes

- Evolution is an orderly change from one form to another.
- **Evolutionary Biology** : Study of history of development of newer life forms from pre-existing ones.

► Origin of Life

- Big Bang theory state that the universe originated about 20 billion years ago by a thermonuclear explosion (big bang) of a dense entity.
- The earth was formed about 4.5–5 billion years ago.
- There was no atmosphere on early earth.
- Water vapour, CH₄, CO₂ and NH₃ released from molten mass covered the surface.

$$\text{H}_2\text{O} \rightarrow \text{H}_2 + \text{O}_2$$

$$\text{NH}_3 + \text{O}_2 \rightarrow \text{NO} + \text{water}$$

$$\text{CH}_4 + \text{O}_2 \rightarrow \text{CO}_2 + \text{Water}$$
- Then the ozone layer was formed.
- As it cooled, the water vapour condensed to fell as rain to form oceans.

► Theories of Origin of Life

(i) **Abiogenesis states that life originated from a simple organic compound :**

- It states that life came out of decaying and rotting matter like straw, mud, etc.
- **Louis Pasteur** (1864) demonstrated that life comes from pre-existing life and dismissed abiogenesis theory.
- He showed that in pre-sterilised flasks, life did not come from killed yeast while in another flask open to air, new living organisms arose.



Mnemonics

Concept : Theories of Origin of life

Mnemonic : All Boys Come in School it's **Compulsory**

Interpretation: Abiogenesis, Biogenesis, Cosmic theory, Special creation theory, Chemical evolution theory



Key Words

Spores : They are minute, One-celled reproductive unit which give rise to a new individual without sexual reproduction.

Progeny : Offspring or children.

Panspermia : Units of life in the forms of spores, which were transferred to earth from outer space (as believed by some scientists).

(ii) Biogenesis

- It was proposed by **Francisco Redi**, **Spallanzani** and **Louis Pasteur**.
- It states that life originates from pre-existing life.

(iii) Cosmic Theory (Theory of **Panspermia**)

- It states that the units of life (**spores**) were transferred to different planets including Earth.

(iv) Theory of Special Creation

- It states that living & non-living things are created by some supernatural power (God).

(v) Theory of Chemical Evolution of life

- It was proposed by **Oparin** and **Haldane**.
- It states that the first form of life was originated from non-living inorganic and organic molecules such as CH_4 , NH_3 , H_2O , sugars, proteins, nucleic acids, etc.
- "Abiogenesis first, but biogenesis ever since".
- **Two hypothetical proposals of Oparin-Haldane's theory are :**
 - (i) **Chemical evolution** from inorganic to organic molecules.
 - (ii) **First life** formed by assembly and interaction of organic molecules.
- This theory is also known as primary abiogenesis.

► Urey-Miller Experiment

- **Harold Urey** & **Stanley Miller** conducted an experiment to prove the theory of chemical evolution.
- They created a condition similar to that of primitive earth (i.e., high temperature, volcanic storms, reducing atmosphere devoid of oxygen but containing compounds of carbon, hydrogen, nitrogen and water).
- They made electric discharge in a closed flask containing CH_4 , NH_3 , H_2 and water vapour at 800°C .
- As a result, some amino acids were formed.
- In similar experiments, others observed the formation of sugars, nitrogen bases, pigments and fats.
- First non-cellular form of life originated 3 billion years ago.
- They were RNA, proteins, polysaccharides, etc.

► Evolution of Life Forms – Various Theory

- Based on observations made during a sea voyage in a survey ship called H.M.S. Beagle round the world, **Charles Darwin** concluded that existing living forms share similarities to varying degrees not only among themselves but also with life forms that existed millions of years ago.
- There had been extinctions of different life forms in the years gone by just as new forms of life, arose at different periods of the history of the earth.
- There has been a gradual evolution of life forms due to variation in characteristics.
- Those characteristics which enable some to survive better in natural conditions (climate, food, physical factors etc.) would outbreed others that are less-endowed to survive under such natural conditions or fitness of the individual or population.
- Fitness, according to Darwin, refers ultimately and only to reproductive fitness.
- Hence, those who are a better fit in an environment, leave more **progeny** than others.
- These, therefore, will survive more and hence are selected by nature.
- He called it natural selection and implied it as a mechanism of evolution.



Key Fact

Alfred Russel Wallace (1823-1913) was a British naturalist and geographer, He independently proposed a theory of evolution due to natural selection. This prompted Charles Darwin to publish his own theory.

- **The modern synthetic theory** : The modern synthetic theory is also known as Neo- Darwinian theory which merges the theory of Darwinian evolution with Mendelian genetics given by many evolutionary biologists such as such as T. Dobzhansky, Sewall Wright, G.I. Stebbins, Ernst Mayr. This theory provide a new definition of evolution as "the change occurring in the allele frequencies within the populations" which emphasises the genetic basis of evolution.

Factors of modern synthetic theory:

- Mutation
- Genetic recombination
- Genetic drift
- Natural selection
- Isolation
- **Alfred Wallace**, a naturalist who worked in the Malay Archipelago also came to similar conclusions around the same time.
- All the existing life forms share similarities and share common ancestors.
- However, these ancestors were present at different periods in the history of the earth.
- The geological history of the earth closely correlates with the biological history of the earth.

► **Evidences for Evolution****1. Palaeontological Evidences**

- The study of fossils is known as paleontology.
- Fossils are remnants of life forms or the parts found preserved in rocks (earth crust).
- Fossils are written documents of evolution.
- **Significance of Fossils**
 - (a) To study phylogeny (evolutionary history or race history) e.g., Horse evolution.
 - (b) To study the connecting link between two groups of organisms e.g., *Archaeopteryx* having reptilian and avian characteristics.
 - (c) To study extinct animals e.g., Dinosaurs.
 - (d) To study about the geological period by analysing fossils in different sedimentary rock layers. The study showed that life forms varied over time and certain life forms are restricted to certain geological periods.

2. Morphological and Anatomical Evidences

- Comparative anatomy and morphological evidences showed that different forms of animals have some common structural features. This can be explained as follows :
 - (a) **Homologous Organs and Homology**
 - Homologous organs are the organs having fundamental similarity in structure and origin but different in functions. This phenomenon is called homology. e.g., Human hand, Whale's flippers, Bat's wings, and Cheetah's foot.
 - All these perform different functions but are constructed on the same fundamental plan.
 - Homology can be seen in the skeleton (e.g., humerus, radius, ulna, carpals, metacarpals & phalanges), heart, blood vessels, excretory system, brain, etc.
 - **Homology in Plants :**
 - (i) The thorns of *Bougainvillea* and tendrils of *Cucurbita*.
 - (ii) The origin of homologous organs is due to divergent evolution.
 - (iii) The divergent evolution is the process by which related species become less similar in order to survive and adapt to different environmental conditions.
 - (iv) Homology indicates common ancestry.
 - (b) **Analogous Organs and Analogy**
 - Analogous organs are organs having similar function but different structure and origin. This phenomenon is called analogy.
 - **Examples**
 - (i) Wings of insects (formed of a thin flap of chitin) and wings of birds (modified forelimbs).
 - (ii) Eyes of Octopus (retina from skin) and mammals (retina from the embryonic brain).
 - (iii) Flipper of Penguins and Dolphins.
 - (iv) Sweet potato (modified root) and Potato (modified stem).
 - (v) Trachea of insects (from ectoderm) and lungs of vertebrates (from endoderm).
 - The origin of analogous organs is due to convergent evolution.
 - The convergent evolution is the process by which unrelated species become more similar to survive and adapt in similar environmental conditions.

3. Adaptive Radiation (Biogeographical Evidences)

- Adaptive radiation (evolution by adaptation) is the evolution of closely related species in a given geographical area starting from a point. e.g.,
 - Darwin's finches (seen in Galapagos Islands).
 - Australian marsupials.
 - Placental mammals in Australia.
- When more than one adaptive radiation occurs in an isolated geographical area, this leads to convergent evolution e.g., Australian Marsupials and Placental mammals.

4. Biochemical Evidences

- Similarities in proteins and genes.
- Similarities in other biomolecules and metabolism.

5. Evidences for Evolution by Natural Selection

- Natural selection is the process by which the organisms that are best suited for their environment survive and reproduce.

Examples of natural selection : Industrial Melanism (In England) :

Before Industrialisation (1850s) :

- There were more white-winged moths (*Biston betularia*) on trees than dark-winged or melanised moths (*Biston carbonaria*).
- Reason :** White coloured lichen covered the trees. In that background, the white-winged moths survived but the dark coloured moths were easily spotted out and picked out by predators.

After industrialisation (1920) :

- More dark-winged moths and less white-winged moths.
- Reason :** The tree trunks became dark due to pollution by industrial smoke and soot. No growth of lichens. Under this condition, the white winged moth did not survive because the predators identified them easily against dark background. Dark winged moth survived because of suitable dark background.
- Excess use of herbicides, pesticides, antibiotics or drugs, etc., resulted in the selection of resistant varieties (natural selection by anthropogenic action).

IMPORTANT DIAGRAM :

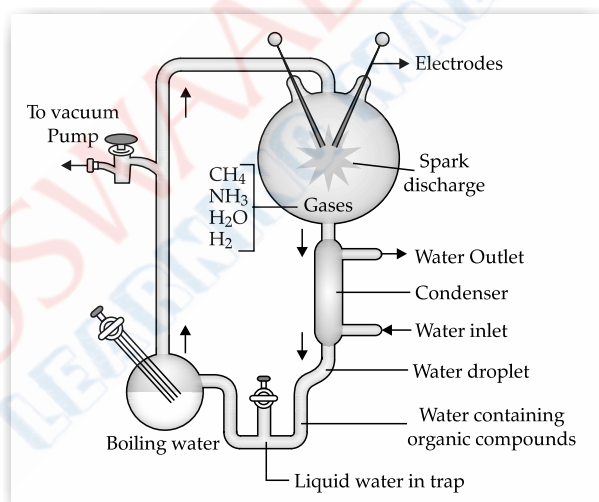

Miller and Urey's Experiment

Example 1

Q. Select two pairs from the following which exhibit divergent evolution. Give reasons for your answers.

- Forelimbs of cheetah and mammals
- Flippers of dolphins and penguins.
- Wings of butterflies and birds.
- Forelimbs of whale and mammals.

Sol. • The two pairs of animal that exhibit divergent evolution are:

- Forelimbs of cheetah and mammals.

(iv) Forelimbs of whales and mammals.

All these animals show similarities in pattern of bones of forelimb but they perform different functions. They have similar anatomical structure. Hence, the same structural organs in these animals have developed in different directions because of adaptations to their different requirements. This shows that the divergent evolution and that the structures/organs are homologous.

Topic-2**Evolutionary Theories, Its Mechanism and Evolution of Man**

Concepts Covered • *Theory of Biological Evolution, Hardy - Weinberg Principle, Human Evolution*

**Revision Notes****1. Darwinism (Theory of Natural Selection)**

- It was proposed by **Charles Darwin (1859)** in his book "**Origin of Species**".
- It is based on two key concepts namely,
 - (a) Branching descent (**Adaptive radiation**)
 - (b) Natural selection (**Convergent evolution**)
- (a) **Branching Descent**
 - It explains that all organisms are modified descendants of previous life forms.
- (b) **Natural Selection**
 - Consider a bacterial colony (say A) growing on a given medium.
 - If the medium composition is changed, only a part of the population (say B) can survive under new conditions. This variant population outgrows the others and appears as new species i.e. B is better than A under new condition.
 - Nature selects for fitness.
 - The work of **Thomas Malthus** on principle of populations (1794) was influenced by **Darwin**.
 - **Natural selection is based on the following facts :**
 - (a) Heritable minor variations.
 - (b) Over production by organisms.
 - (c) Limited natural resources.
 - (d) Struggle for existence for food and space.
 - (e) Survival of the fittest.
 - Population size grows exponentially if everybody reproduces maximally (e.g., bacterial population).
 - In fact, population size is limited due to competition for resources (Struggle for existence).
 - Only some survives (Survival of the fittest).
 - Darwin said that the organisms with heritable variations make resource utilisation better.
 - They reproduce and leave more progeny.
 - It leads to a change in population characteristics and new forms appear.

**Key Words**

Adaptive Radiation: It is the process of evolution of different species starting from a point in a geographical area and finally radiating to other areas of geography.

Convergent Evolution: It is the evolutionary process where anatomically different structures in different group of organisms evolve towards the same function.

Natural Selection: It is the process of occurring in nature that acts over a number of generations and slowly increases the proportion of those individuals which are adapted to the environment due to their heritable characters.

► **Mechanism of Evolution**

- Darwin ignored about origin of variation and mechanism of speciation.

► **Mutation Theory**

- **Hugo de Vries** (1901) proposed Mutation Theory of evolution in his book "Mutation theory".
- He conducted some experiments on *Oenothera lamarckiana* (evening primrose) and believed that evolution takes place through mutation and not by minor variation.
- Evolution for Darwin was gradual while for de Vries it is a sudden / spontaneous process. He believed mutation caused speciation and hence called it **saltation** (single step large mutation).

► **Differences between Darwinian Variation & Mutation**

Darwinian Variation	Mutation
It shows minor variation.	It shows large variation.
It is slow and directional.	It is random, sudden and directionless.
It showed gradual evolution.	It showed discontinuous evolution and speciation by saltation.
It is caused by reshuffling of genes.	It is caused by change in the genetic material.

▶ Hardy - Weinberg Principle

- It says that allele frequencies in a population are stable and constant from generation to generation.
- The gene pool (total genes and their alleles in a population) remains constant. This is called genetic equilibrium (Hardy-Weinberg equilibrium).



Mnemonics

Concept: Factors Affecting Hardy- Weinberg Equilibrium

Mnemonic: 3G Modern Network

Interpretation: Gene migration, Genetic drift, Genetic recombination, Mutation, Natural selection.

- Sum total of all the allelic frequencies = 1. e.g., In a diploid, p and q are the frequencies of alleles A & a respectively.
- The frequency of $AA = p^2$ (i.e., the probability of an allele A with frequency p is the product of the probabilities, i.e., p^2)
- The frequency of $aa = q^2$
- The frequency of $Aa = 2pq$
- Hence $p^2 + 2pq + q^2 = 1$ [binomial expansion of $(p+q)^2$]
- Change of frequency of alleles in a population causes disturbance in genetic equilibrium. This is due to evolution.

▶ **Factors Affecting Hardy-Weinberg Equilibrium :** There are time basic processes which may bring about the change in Hardy Weinberg equilibrium and bring about the variations at the genetic level as follows :

(a) Gene Migration

- Gene flow from one population to another.
- Here, gene frequencies change in both populations.
- There would be a gene flow if migration happens multiple times.

(b) Genetic Drift

- The accidental gene flow causing change in frequency.
- Sometimes, the change in frequency is so different in the new sample of population that they become a different species.
- The original drifted population becomes founders and the effect is called founder effect.

(c) Mutation

- Mutations result in formation of new phenotypes.
- Over few generations, this leads to speciation.

(d) Genetic Recombination

- It is the reshuffling of gene combinations during crossing over resulting in genetic variation.

(e) **Natural Selection :** It is the major factor which adds variations in the population, change the gene frequencies in the **gene pool** resulting in the formation new **gene pool**. These are of three types namely, Stabilising selection, Directional selection and Disruptive selection.

- Stabilising Selection :** Here, more individuals acquire average character value and variation is reduced.
- Directional Selection :** Here, individuals of one extreme are more favoured.
- Disruptive Selection :** Individuals of both the extremes are favoured. It produces two peaks that may lead to the development of two different populations.



Key Fact

Basic unit of natural selection is individual. *Australopithecus* is considered as the connecting link between man and apes.

▶ Origin and Evolution of Man (Human ancestry)

(i) *Dryopithecus* & *Ramapithecus* (15 mya)

- Hairy.
- Walked like gorillas and chimpanzee.
- Dryopithecus* : ape-like.
- Ramapithecus* : man-like.
- Fossils of man-like bones found in Ethiopia and Tanzania.
- Man-like primates (3-4 mya) : Height up to 4 feet.

(ii) *Australopithecus* (2 mya)

- In East African grasslands.
- Hunted with stone weapons.
- Ate fruits.

(iii) *Homo habilis*

- First human-like being (hominid).

- Brain capacity : 650-800 cc.
 - Did not eat meat.
- (iv) **Homo erectus (1.5 mya)**
- Large brain (900 cc) : Ate meat.
- (v) **Neanderthal man : 40,000 - 1 lakh yrs ago :**
- Brain 1400 cc.
 - Lived in East and Central Asia.
 - Used hides to protect their body.
 - Buried their dead.
- (vi) **Homo sapiens (Modern man) :** Evolution took place during 10,000 to 75,000 years ago.
- Pre-historic cave art developed about 18,000 years ago.
 - Agriculture and settlements : 10,000 years ago.

Example 2

Q. Write two differences between *Homo erectus* and *Homo habilis*.

Sol. (a) Differences between *Homo erectus* and *Homo habilis* are as follows:

<i>Homo erectus</i>	<i>Homo habilis</i>
Had a large brain around 900 cc.	Had brain capacities between 650-800 cc.
Walked in an upright posture.	Stooped over while walking.
Probably ate meat.	Probably did not eat meat.

UNIT – VIII: BIOLOGY AND HUMAN WELFARE

CHAPTER-7

HUMAN HEALTH AND DISEASES

Topic-1

Health, Common Human Diseases and Immunity

Concepts Covered • Types of diseases, Different microorganisms causing different type of diseases, life cycle of *Plasmodium*, Immune system, Immunisation, AIDS and cancer.



Revision Notes

► Human Diseases and Immunity

- Health is a state of complete physical, mental and social well-being.
- Health is affected by genetic disorders, infections, sedentary lifestyle (Junk food, lack of exercise, habits, etc).
- **Disease:** A disease can be defined as any condition that may lead to discomfort, distress, health problems or death of the affected person.
- **Congenital diseases:** These are diseases that are present since birth. For instance, a hole in the heart of an infant. They are caused by some genetic abnormalities or metabolic disorder or malfunctioning of an organ.
- **Acquired diseases:** These are diseases that may occur after birth during one's lifetime.
- Among non-infectious diseases, cancer is the major cause of death.
- Pathogens are disease-causing organisms.
- Parasites are pathogens as they harm the host by living in or on them.
- Pathogens have to adapt to live within the environment of the host.

► Common Infectious Diseases in Man

1. BACTERIAL DISEASES

(a) Typhoid

- **Pathogen:** *Salmonella typhi*.
- **Mode of transmission:** It enters the small intestine through food and water and migrates to other organs through blood.

- **Symptoms:** Sustained high fever (39°- 40°C), weakness, stomach pain, constipation, headache and loss of appetite. Intestinal perforation and death may occur.
 - **Confirmation:** The Widal test is used for confirmation of the disease.
- (b) **Pneumonia**
- **Pathogen:** *Streptococcus* or *Diplococcus pneumoniae* and *Haemophilus influenzae*.
 - **Mode of transmission:** Inhaling the droplets/aerosols released by an infected person. Sharing glasses and utensils with an infected person.
 - **Symptoms:** Infects lung's alveoli. The alveoli get filled with fluid leading to respiratory problems. Fever, chills, cough, headache.
 - **Severe cases:** Lips and fingernails turn grey to a bluish colour.
 - **Dysentery, plague, diphtheria** are some other bacterial diseases in humans.



Key Words

Hemozoin: It is a brownish black granular material within the red blood cell, which is generated during host haemoglobins degradation by the parasite.

Sporozoite: It is a motile spore-like stage of some parasitic sporozoans, which act as an infective agent.

2. VIRAL DISEASES

(a) Common cold

- **Pathogen:** Rhino viruses
- **Mode of transmission:** Inhaling droplets resulting from cough or sneezes through contaminated objects.
- **Symptoms:** Infects nose and respiratory passage. Nasal congestion and discharge, sore throat, hoarseness, cough, headache, tiredness, etc., Last for 3-7 days.



Key Facts

- *Aedes aegypti*, vector of a viral disease, Dengue fever, is a daytime biting mosquito.
- National T.B. programme was started in 1962.
- Hepatitis B is more dangerous than AIDS

3. PROTOZOAN DISEASES

(a) Malaria

- **Pathogen:** *Plasmodium* sp. (*P. vivax*, *P. malariae*, *P. ovale*. and *P. falciparum*).
- **Mode of transmission:** Biting of *Anopheles* mosquito.
- **Symptoms:** **Haemozoin** causes chill and high fever recurring every 3-4 days.

Life cycle of Plasmodium:- The life cycle of *Plasmodium* has three phases - *Schizogony*, *gamogony* and *sporogony*. Female *Anopheles* mosquito is the primary host while man is the secondary host.

Life cycle of Plasmodium in Man:

- The infective stage of *Plasmodium* is the **sporozoite**, which is injected into the blood of the human by the bite of female *Anopheles* mosquito.
- From the human blood, sporozoites reach the liver cells where they multiply.
- The liver cells rupture to liberate the parasites into the blood where they attack the RBCs, multiply and cause their rupture.
- The rupture is associated with the release of a toxin called haemozoin, which is responsible for the recurring chill and high fever within 3 - 4 days.
- The development of gametocytes takes place in the RBCs, which are of two types: male gametocytes or microgametocytes, and female gametocytes or macrogametocytes.

Life cycle of Plasmodium in Female Anopheles Mosquito

- When a female *Anopheles* mosquito sucks the blood of an infected human host, it receives the RBCs including gametocytes.
- Further development occurs in the stomach wall of the mosquito, the gametes fuse to form a zygote.
- The zygote undergoes further development to form sporozoites.
- The sporozoites after liberation from the stomach wall move to different organs in the body cavity, but many of them penetrate the salivary glands.
- The mosquito now becomes infective, when the female *Anopheles* mosquito bites a healthy person the sporozoites are injected in his / her blood along with saliva.

(b) Amoebiasis (Amoebic dysentery) or Enteritis.

- **Pathogen:** *Entamoeba histolytica* found in the large intestine of humans.
- **Mode of transmission:** Houseflies (mechanical carriers) transmit **parasites** from the faeces of an infected person to food and water and thereby contaminating them.
- **Symptoms:** Constipation, abdominal pain and cramps, stools with excess mucous and blood clots.



Key Word

Parasite: An organism residing on organism of another species (it's host) and draws benefit by deriving nutrients from its host.

4. HELMINTH DISEASES

(a) Ascariasis

- **Pathogen:** *Ascaris lumbricoides* (Intestinal parasite).
- **Mode of transmission:** Soil, water, vegetables, fruits, etc., contaminated with faeces containing eggs of parasites.
- **Symptoms:** Internal bleeding, muscular pain, fever, anaemia and blockage of intestinal passage.

(b) Filariasis (Elephantiasis)

- **Pathogen:** Filarial worms or *Wuchereria* (*W. bancrofti* & *W. malayi*).
- **Mode of transmission:** Bite of female *Culex* mosquito.
- **Symptoms:** Filarial worms live in lymphatic vessels (usually of lower limbs). It causes chronic **inflammation** of the organs, in which they live for many years. Limbs and genital organs may be deformed.

5. FUNGAL DISEASES

(a) Ring worms

- **Pathogens:** *Microsporium*, *Trichophyton* & *Epidermophyton*. They are seen in groin between the toes.
- **Mode of transmission:** From soil or by using towels, cloths, comb, etc. Heat and moisture help fungi to grow.
- **Symptoms:** Appearance of dry, scaly lesions on various body parts such as skin, nails and scalp. Intense itching.



Key Word

Inflammation: A process by which our body's WBC protect us from infection from outside invaders, such as bacteria and viruses. It can be either short-lived (acute) or long-lasting (chronic).

Other Infectious Diseases

(i) Bacterial Diseases

Disease	Pathogen	Transmission
Dysentery	<i>Shigella</i>	Contact, Contaminated food and water
Plague	<i>Pasteurella pestis</i>	Rat fleas
Diphtheria	<i>Corynebacterium diphtheriae</i>	Contaminated food, Direct contact
Cholera	<i>Vibrio cholerae</i>	Food & water contaminated with faeces
Tuberculosis	<i>Mycobacterium tuberculosis</i>	Droplets from patient/carrier
Tetanus	<i>Clostridium tetani</i>	Contamination of wound by bacteria
Whooping cough	<i>Bordetella pertussis</i>	Contact, Droplets
Leprosy	<i>Mycobacterium leprae</i>	Direct contact
Anthrax	<i>Bacillus anthracis</i>	Contact with cattle
Weil's disease	<i>Leptospira</i>	Contact with rodents, dogs, etc.

(ii) Viral Diseases

Disease	Pathogen	Transmission
Rabies	Rabies virus	Rabid dogs.
Dengue	Dengue virus	<i>Aedes</i> mosquito
Influenza	Influenza virus	Coughing & Sneezing
Measles	Rubeola virus	Droplets
German measles	Rubella virus	Close contact
Mumps	Mumps virus	Airborne droplets
Chickenpox	<i>Varicella zoster</i>	Airborne droplets
Smallpox	Variola virus	Direct contact
Polio	Polio virus	Faeces & Air
Chikungunya	CHIK virus	<i>Aedes</i> mosquito
Avian flu	H ₅ N ₁ virus	Contact with infected poultry. Airborne spread
H ₁ N ₁ (Swine flu)	H ₁ N ₁ virus	Contact with pigs, cough & sneeze of infected person.

► **Prevention and Control of Diseases**

1. **Personal Hygiene:** Keep the body clean. Use clean drinking water, food, etc.

2. **Public Hygiene**

- (a) Proper disposal of wastes and excreta.
- (b) Periodic cleaning and disinfection of water reservoirs, pools, cesspools and tanks.
- (c) Avoid contact with infected persons or their belongings (to control air-borne diseases).
- (d) Standard practices of hygiene in a public gathering.
 - **Control and eliminate the vectors (e.g., mosquitoes) and their breeding places by following methods:**
 - (i) Avoid stagnation of water.
 - (ii) Regular cleaning of household coolers.
 - (iii) Use of mosquito nets.
 - (iv) Introduce larvivorous fish like *Gambusia* in ponds.
 - (v) Spraying insecticides in ditches, drainage and swamps.
 - (vi) Doors and windows should be provided with wire mesh to prevent the entry of mosquitoes.

These precautions can avoid vector-borne diseases like malaria, filariasis, dengue and chikungunya.

► **Immune System**

- It is the system that gives immunity to the body by recognizing, responding and remembering foreign antigens.
- It plays an important role in an allergic reaction, auto-immune disease and organ transplantation.
- It includes lymphoid organs, tissues, cells and soluble molecules like antibodies.

► **Lymphoid Organs**

- These are the organs where origin, maturation and proliferation of lymphocytes occurs.
- These are of two types namely, primary lymphoid organs and secondary lymphoid organs.

(a) **Primary Lymphoid Organs**

- Here, immature lymphocytes differentiate into antigen-sensitive lymphocytes e.g., Bone marrow and thymus.
- Bone marrow is the main lymphoid organ and is the site of formation of all the blood cells including lymphocytes.
- Thymus is large during birth but gradually reduces in size and becomes very small size at puberty.
- Growth and maturation of T-lymphocytes takes place here.

(b) **Secondary Lymphoid Organs**

- The organs to which matured lymphocytes migrate, interact with antigens and then proliferate to become effector cells e.g., Spleen, lymph nodes, tonsils, Peyer's patches, MALT and appendix. Secondary lymphoid organs are:

(i) **Spleen:**

- (i) It is a bean-shaped organ.
- (ii) It contains lymphocytes and phagocytes.
- (iii) It removes worn-out RBCs and microorganisms from blood.
- (iv) It is a reservoir of erythrocytes in the foetus.

(ii) **Lymph Nodes**

- (i) These are found in the lymphatic system.
- (ii) They trap microorganisms or other antigens that enter the lymph and tissue fluid.
- (iii) The trapped antigens activate lymphocytes and cause an immune response.

(iii) **Mucosa Associated Lymphoid Tissue (MALT):**

- (i) It is located within the lining of respiratory, digestive and urinogenital tracts.
- (ii) It constitutes 50% of lymphoid tissue in the human body.

► **Immunity**

- It is the ability of the immune system of the body to fight against the disease-causing organisms.
- It is of two types namely Innate immunity and Acquired immunity.

(a) **Innate Immunity**

- It is the *non-specific* defence present at the time of birth.
- It provides barriers to the entry of foreign agents into our body.
- It consists of four types of barriers:
 - (i) **Physical Barriers**
 - Skin on our body is the first and main barrier that prevents entry of the micro-organisms. It is the first line of defence.
 - Mucus coating of the epithelium lining the respiratory, gastrointestinal and urogenital tracts also help in trapping microbes entering our body.
 - (ii) **Physiological Barriers:** Acid in the stomach, saliva in the mouth, tears from eyes—all prevent microbial growth.
 - (iii) **Cellular Barriers:** Certain types of leukocytes (WBC) of our body like polymorpho-nuclear leukocytes (PMNL-neutrophils) and monocytes and natural killer (type of lymphocytes) in the blood as well as macrophages in tissues can phagocytose and destroy microbes.
 - (iv) **Cytokine Barriers:** Virus-infected cells secrete proteins called *interferon* which protect non-infected cells from further viral infection.

(b) Acquired Immunity

- It is a pathogen-specific immunity.
- It is not present since birth but develops during the lifetime of an individual.
- It is characterized by memory i.e., during the first encounter of a pathogen; our body produces a primary response in low intensity. The second encounter with the same pathogen produces a secondary (anamnestic) response in high intensity.
- The primary and secondary immune responses are carried out with B-lymphocytes and T-lymphocytes.
 - (a) B-lymphocytes (B-cells): Produce antibodies.
 - (b) T-lymphocytes: Help B-cells to produce antibodies.

► Structure of an Antibody Molecule

- Each antibody has 4 polypeptide chains namely, 2 small light chains and 2 large heavy chains (H_2L_2).
- In our body, different types of antibodies such as IgG, IgA, IgM, IgE & IgD are produced.
- Acquired immune response is of two types namely humoral mediated response and cell-mediated response.
 - (a) **Humoral or Antibody-Mediated Response/Antibody-Mediated Immunity (AMI)**
 - Antibodies are found in blood plasma. So, it is called as humoral immune response.
 - It includes B-lymphocytes and T-lymphocytes. The latter help the former to produce antibodies.
 - (b) **Cell-Mediated Response/Cell-Mediated Immunity (CMI)**
 - It is T-lymphocytes (T-cells) mediated (CMI).
 - CMI causes Graft rejection.
 - The body can differentiate 'self' and 'non-self'.
 - Tissue matching and blood group matching are essential before undertaking any graft / transplant. After this, the patient has to take immune-suppressants for all his life.

► Types of Acquired Immunity: Acquired immunity is of two types i.e., active and passive Immunity.**(a) Active Immunity**

- The immunity in which antibodies are produced in a host body when the host is exposed to antigens (e.g., living or dead microbes or other proteins) is known as active immunity.
- It is a slow process.
- It is produced in 2 ways:
 - (i) **Natural Active Immunity:** During natural infection by microbes.
 - (ii) **Artificial Active Immunity:** Injecting the microbes deliberately during immunization.

(b) Passive Immunity:

- Here, ready-made antibodies are directly given to protect the body.
- It is of two types-:
 - (i) **Natural Passive Immunity-:** e.g., Antibodies (IgG) from mother → Placenta → Foetus → Antibodies (IgA) in colostrum → infants.
 - (ii) **Artificial Passive Immunity-:** e.g., Anti-tetanus serum (ATS).

► Immunization

- This is based on the 'memory' of the immune system.
- It is of two types namely active immunization and passive immunization.
 - (a) **Active Immunization (Vaccination)**
 - A preparation of vaccine (antigenic proteins of pathogen or inactivated pathogen) is introduced into the body.
 - The antibodies produced in the body against the antigens neutralize the pathogenic agents during actual infection.
 - The vaccines also generate memory B and T-cells that recognize the pathogen quickly e.g., Polio vaccine, Hepatitis B vaccine, DPT vaccine etc.
 - Vaccines are produced using DNA recombinant technology (e.g., Hepatitis B vaccine produced from Yeast). Such vaccines are called as second-generation vaccines.
 - The vaccines produced by conventional methods e.g., small pox-vaccines are called first-generation vaccine and those which are synthetic vaccine are the third generation vaccine.
 - (b) **Passive Immunization**
 - It is the direct injection of preformed antibodies or antitoxin. It is for quick immune response e.g., Immunization against tetanus, snake venom, etc.

► Allergies

- It is the exaggerated or hypersensitive response of the immune system to certain antigens present in the environment.
- Allergens are substances causing allergy e.g., mites in dust, pollens, animal dander, fur, etc.
- Antibodies produced against the allergens are of IgE type.
- Allergy is due to the release of chemicals like histamine and serotonin from the mast cells.

- **Symptoms:** Sneezing, watery eyes, running nose, difficulty in breathing, etc.
- Determination of cause of allergy: The patient is exposed to or injected with very small doses of possible allergens and the reactions studied.
- Treatment, Drugs like anti-histamine, adrenaline and steroids quickly reduce the symptoms of allergy.
- Modern-day lifestyle results in lowering of immunity and more sensitivity to allergens.
- Asthma is a respiratory disease due to allergy.

► Auto Immunity

- It is caused due to genetic and other unknown reasons. The body attacks self cells. This results in auto-immune disease.
- It is memory-based acquired immunity evolved in higher vertebrates based on the ability to differentiate foreign organisms (e.g., pathogens) from self-cells e.g., Rheumatoid arthritis.

► AIDS (Acquired Immunodeficiency Syndrome)

- Syndrome is a group of symptoms.
- AIDS is the deficiency of the immune system.
- It is caused by HIV (Human Immunodeficiency Virus), a retrovirus having an RNA genome.
- AIDS was first reported in America (1981).
- **Mode of Transmission:**
 - (a) Sexual contact with an infected person.
 - (b) Transfusion of contaminated blood and blood products.
 - (c) Sharing of infected needles.
 - (d) From infected mother to her child through the placenta.
- **High risk of getting HIV includes**
 - (a) Individuals with multiple sexual partners.
 - (b) Drug addicts who take drugs intravenously using infected syringes.
 - (c) Individuals who require a repeated blood transfusion.
 - (d) Children born to an HIV infected mother.
- **HIV does not spread by touch or physical contact.**
- It spreads only through body fluids.
- There is always a time-lag (from few months to 5-10 years) between the infection and appearance of symptoms.
- **Life Cycle of HIV Virus:**
- HIV enters into body → To macrophages (acts as HIV factory) → RNA genome replicates in presence of Reverse transcriptase to form viral DNA → Viral DNA incorporates into host DNA → Infected cells produce virus particles → HIV enters into helper T-cells (T_H) → Replicates and produce progeny viruses → Attack another helper T-cells → T-cells decrease → Weaken immunity.
- HIV infected person may be infected with *Mycobacterium*, viruses, fungi and parasites like *Toxoplasma*.
- **Diagnosis of AIDS:** ELISA test (Enzyme-Linked Immune-Sorbent Assay) PCR-Test, western blotting, etc.
- **Treatment of AIDS**
- Anti-viral drugs partially effective.
- They can only prolong the life of the patient.
- **Prevention of AIDS**
 - (i) Educate people about AIDS.
 - (ii) Making blood (from blood banks) safe from HIV.
 - (iii) Use of disposable needles and syringes.
 - (iv) Advocating safe sex and free distribution of condoms.
 - (v) Controlling drug abuse.
 - (vi) Regular check-ups for HIV in a susceptible population.

► Cancer

- Cancer is an abnormal and uncontrolled multiplication of cells resulting in the formation of tumour (masses of cells).
- Normal cells show a contact inhibition (contact with the other cells inhibits their uncontrolled growth). Cancer cells do not have this property.
- Tumours are of two types namely Benign tumour and Malignant tumour.
 - (a) **Benign Tumour**
 - It is confined to the place of its origin and does not spread to other parts of the body.
 - It is harmless or causes less damage to the body.
 - (b) **Malignant Tumor**
 - It spreads and invades nearby tissues.
 - It is harmful.
- **Metastasis:** The spread of cancer cells from one part of the body to another.
- **Types of Cancer**
- **Carcinoma:** cancer of epithelial cells.
- **Sarcoma:** cancer of connective tissues.
- **Melanoma:** cancer of melanocytes.
- **Leukemia:** blood cancer.
- **Lymphomas:** cancer of spleen and lymph nodes.

Causes of Cancer (Carcinogens)

- (a) **Physical agents:** e.g., Ionizing radiations like X-rays and gamma rays and non-ionizing radiations like UV.
- (b) **Chemical agents:** Tobacco smoke (a major cause of lung cancer), vinyl chloride, caffeine, nicotine, mustard gas, etc.

- (c) **Biological agents:** e.g., oncogenic viruses, cellular oncogenes (c-onc) or proto oncogenes, etc. When a C-onc in normal cells is activated, the cells becomes oncogenic.
- **Cancer Detection and Diagnosis**
 - (a) **Biopsy:** A thin piece of the suspected tissue is stained and examined under a microscope (histopathological studies).
 - (b) **In case of leukaemia:** Biopsy and histopathological studies. Blood and bone marrow tests for increased cell counts.
 - (c) **Radiography (use of X-rays):** CT (Computerized Tomography) scan and MRI (Magnetic Resonance Imaging).
 - (d) **Use of antibodies** against cancer-specific antigens.
 - (e) **Techniques of molecular biology** to detect genes related to cancer. Such individuals may be advised to avoid exposure to particular carcinogens (e.g., tobacco smoke).
 - **Treatment of Cancer**
Most cancers are treated by a combination of surgery, radiotherapy and chemotherapy.
 - (a) **Radiation therapy:** Tumour cells are irradiated lethally without damaging surrounding normal tissues.
 - (b) **Chemotherapy:** Use of chemotherapeutic drugs. Many drugs have side effects like hair loss, anaemia, etc.
 - (c) **Immunotherapy:** The patients are given biological response modifiers (e.g., α -interferon) which activates their immune system and helps in destroying the tumour.



Mnemonics

1. **Concept:** Helminth diseases

Mnemonic: He Finished Assignment

Interpretation: Helminth, Filariasis, Ascariasis

2. **Concept:** Viral diseases

Mnemonics: Vice Chancellor

Interpretation: Viral, Common cold

3. **Concept:** Protozoan diseases

Mnemonic: Pre Medical Association

Interpretation: Protozoa, Malaria, Amoebiasis

IMPORTANT DIAGRAMS:

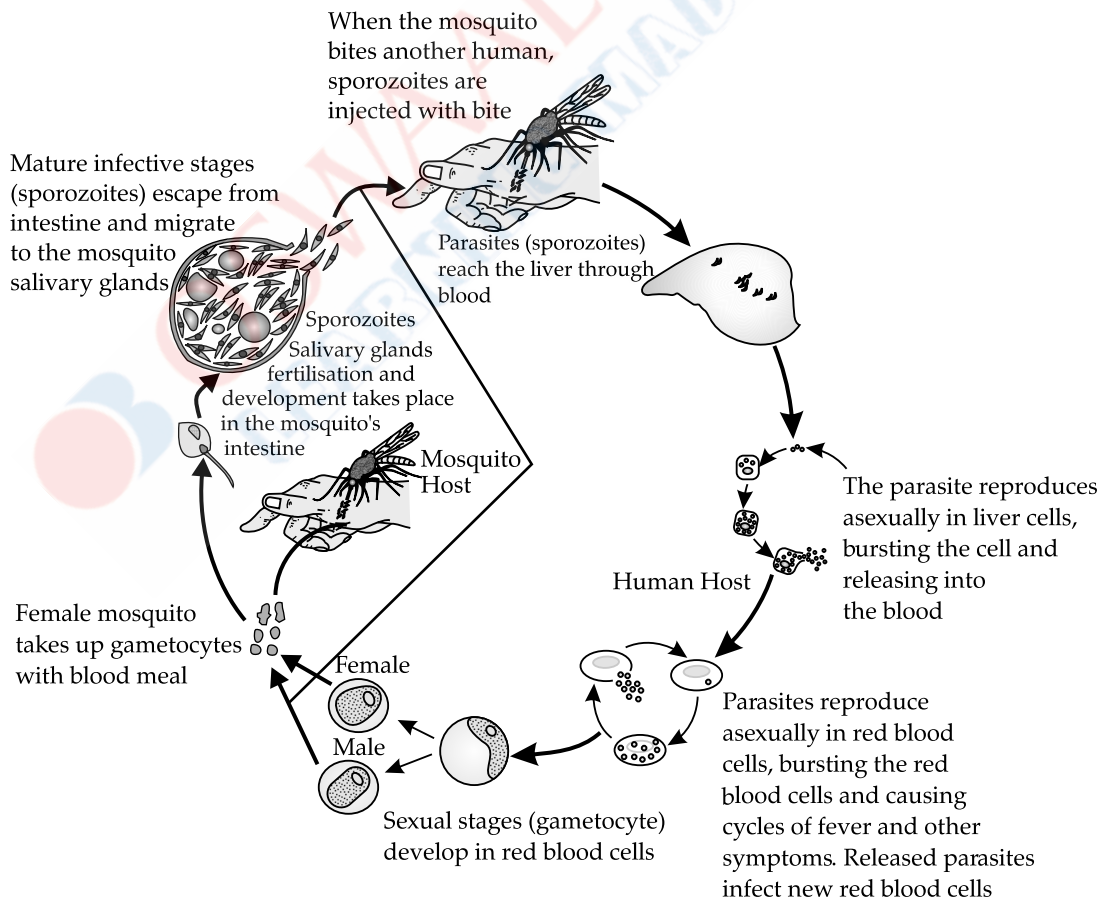

Fig. 7.1: Stages in the Life Cycle of *Plasmodium*

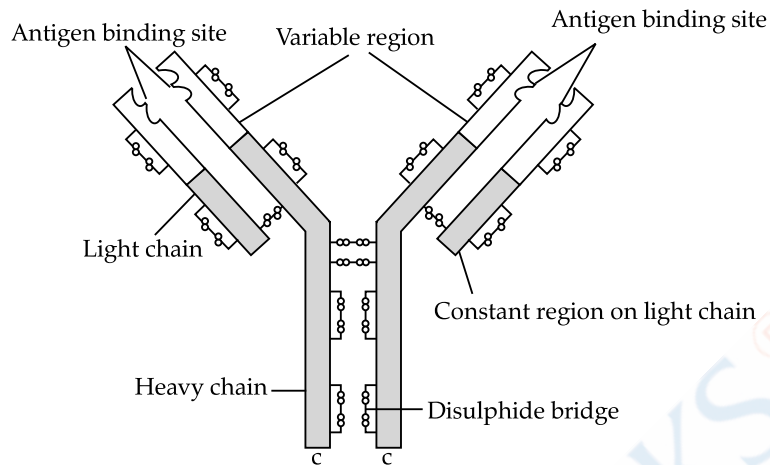

Fig. 7.2: Structure of an antibody molecule

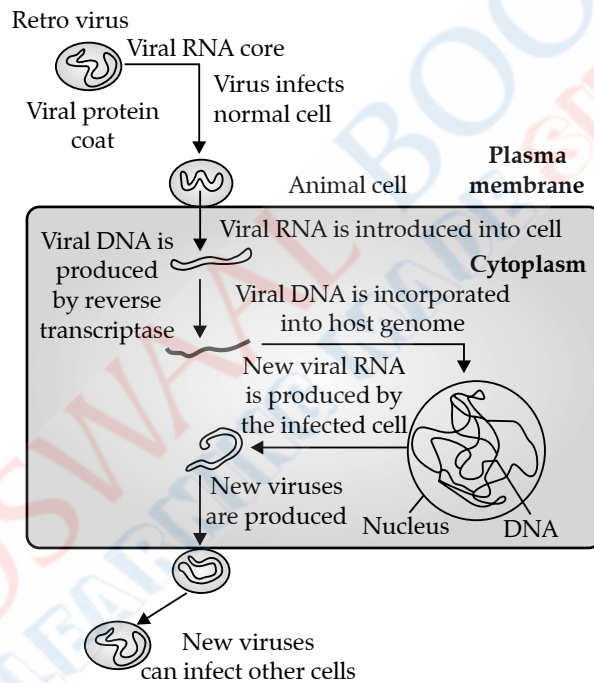

Fig. 7.3: Replication of Retrovirus

Example 1

- Q. (i) Name any two helminths which are known to be pathogenic to human.
 (ii) List two symptoms of the diseases caused by any one of them.

Sol. Ans. (i) The two helminths that are pathogenic to humans are:

- (a) *Ascaris*: Causing ascariasis disease in humans.
 (b) *Wuchereria bancrofti* & *W. malayi* causing Filariasis or elephantiasis in humans.

- (ii) The symptoms of the pathogenic diseases caused by helminths are as follow:

(a) **Symptoms of Ascariasis:** Internal bleeding, muscular pain, anaemia, blockage of intestinal passage.

(b) **Symptoms of Filariasis:** Chronic inflammation of lymphatic vessels of lower limbs and gross deformities of genital organs.

Topic-2**Drugs and Adolescence****Concepts Covered** • Drugs and their types, Effects of drugs and alcohol.**Revision Notes****Drugs and their effects**► **Drugs**

- These can alter the activity of the nervous system.
- They are also called as psychotropic drugs or mood-altering drugs or neurological drugs.
- These drugs change the mood, feelings, behaviour and power of perception.
- The sources of most of the drugs are mainly flowering plants and some fungi.

► **Types of Drugs**

- The drugs, which are commonly abused are opioid, cannabinoids and coca alkaloids.
- These drugs are of the following main types:

1. Depressants

- Depress brain activity.
- They include
 - (a) **Sedatives:** Give calmness and relaxation. High doses induce sleep. e.g., Barbiturates (sleeping pills).
 - (b) **Tranquilizers:** Lower tension and anxiety without inducing sleep. e.g., Benzodiazepines (e.g., Valium).

2. Opiate Narcotics (Pain killers)

- Drugs that bind to specific opioid receptors in CNS and gastrointestinal tract.
- They are analgesic and depressant (lower tension, anxiety, B.P and respiration rate and reduce visual activity) e.g., Opium and its derivatives (Opiates or Opioids).
- Opium is obtained from dried latex of unripe capsules of Poppy plant (*Papaver somniferum*).

► **Opium Derivatives**

- (a) **Morphine:** Strong analgesic and sedative extracted from the latex of poppy plant. Useful during surgery.
- (b) Brown sugar
- (c) **Heroin (Diacetyl morphine/smack):** Most dangerous, white, odourless, bitter crystalline compound produced by acetylation of morphine. It is a depressant and slows down body functions. It is taken by snorting and injection.

**Key Words****Analgesic:** Drug used as pain reliever.**Sedative:** Drugs are meant for inducing sleep. Drug is CNS (Central Nervous System) depressants.**Hallucination:** An experience in which we see, hear, feel or smell something that actually does not exist. It could be due to side effect of some drug or any disease.(d) **Codeine:** Mild analgesic. Used in cough syrups.**3. Stimulants**

- Stimulates CNS e.g., Cocaine, Caffeine (cardiac stimulant), amphetamines (synthetic).
- Amphetamines & anabolic steroids are misused by some athletes.
- Coca alkaloid (Cocaine or coke / crack): Obtained from the coca plant (*Erythroxylum coca*).
- Interferes the transport of neurotransmitter dopamine.
- Cocaine is usually snorted.
- Stimulate CNS producing euphoria and energy.
- Excessive dosage causes hallucination.

4. Hallucinogens

- Cause hallucinations, changing thoughts, feelings and perceptions e.g., Mescaline, Psilocybin, Cannabinoids and LSD (Lysergic Acid diethylamide).
- Atropa belladonna & Datura are plants with hallucinogenic property.

5. Cannabinoids

- Drugs (a group of chemicals) that interact with cannabinoid receptors in the brain.
- Generally taken by inhalation and oral ingestion.
- Natural cannabinoids are obtained from *Cannabis sativa* (Hemp plant). It's flower tops, leaves & resin are used to produce bhang, ganja, charas (hashish), marijuana, etc.
- Affects the cardiovascular system.

► **Alcoholism**

- Alcohols include beverages and spirits.

- (a) **Beverages:** Wine, beer and toddy (5-15% alcohol).
- (b) **Spirits:** Whisky, brandy, rum, gin, arrack, etc. (more than 50% alcohol).
- The victims of alcoholism are known as alcoholics.

► **Effects of Alcoholism**

- (a) Affects thinking ability, speech, movements, reflexes, etc.
- (b) Amnesia, blurred vision, loss of body balance, nausea, vomiting, headache, etc.
- (c) **Cirrhosis** and fatty liver.
- (d) Alcoholic polyneuritis and loss of appetite.
- (e) Cardiovascular diseases and hypertension.
- (f) Ulcer, pancreatitis and gastritis.
- (g) Loss of sexual drive and necrospemia.
- (h) Foetal alcohol syndrome (FAS or Alcohol Embryopathy).
- (i) Family and social problems.



Key Facts

- It is estimated that around 1% of the world population has a drug use disorder.
- The U.S. has the highest overdose rates from all three leading illicit drugs: opioids, cocaine and amphetamine.
- Opioids are responsible for largest number of overdoses from illicit drugs.
- Illicit drugs are those drugs that have been prohibited under international drug control treaties.

• **Effects of Alcoholism on Traffic Accidents**

- (a) Affects co-ordination and correct judgment of distance.
- (b) Affects vision causing Tunnel vision.
- (c) Increases reaction time.
- (d) Affects behaviour.

• **De-alcoholism**

- Medical treatment.
- Social methods of treatment (Group therapy).
- Aversion therapy (Behavioural treatment).

► **Smoking**

- Tobacco is smoked, chewed or used as a snuff.
- Tobacco contains nicotine (an alkaloid) which stimulates the adrenal gland to release adrenaline and nor-adrenaline causing high BP and heart rate.
- Smoking causes cancers of lung, urinary bladder and throat, bronchitis, emphysema, coronary heart disease, gastric ulcer, etc. Tobacco chewing causes oral cancer.
- Smoking increases CO (Carbon monoxide) content in blood and reduces oxyhaemoglobin. This causes O₂ deficiency in the body.

► **Adolescence**

- It is 'a period' and 'a process' during which a child becomes mature in terms of his / her attitudes and beliefs for effective participation in society.
- Adolescence is a bridge linking childhood and adulthood (period of 12-18 years of age). It is very a vulnerable phase of mental and psychological development.
- **Causes of Drug or Alcohol use in Adolescence period**
 - (a) Curiosity and experimentation.
 - (b) Need for adventure and excitement.
 - (c) To escape facing problems.
 - (d) Stress from pressure to excel in academics or examination.
 - (e) Television, movies, newspapers, internet, etc.
 - (f) Unstable or unsupportive family structures and peer pressure.

► **Addiction**

- It is a psychological attachment (euphoria and a temporary feeling of well being) with drugs and alcohol.
- With repeated use of drugs, the tolerance level of the receptors increases. Thus, the receptors respond only to higher doses leading to greater intake and addiction.



Key Word

Cirrhosis: It is a disease of liver, marked by degeneration of cells.

► **Dependence**

- It is the tendency of the body to manifest a characteristic and unpleasant withdrawal syndrome if a regular dose of drugs / alcohol is abruptly discontinued.
- This results in anxiety, shakiness, nausea and sweating.
- Dependence leads to social adjustment problems.

► **Effects of Drug or Alcohol Abuse**

- (a) Reckless behaviour, vandalism and violence.
- (b) Coma and death due to respiratory failure, heart failure or cerebral haemorrhage.
- (c) Drugs together with alcohol may cause death.
- (d) Drop in academic performance and absence from school.
- (e) Lack of interest in personal hygiene.
- (f) Withdrawal and isolation.
- (g) Depression, fatigue, aggressive and rebellious behaviour, the deteriorating relationship between family and friends.
- (h) Loss of interest in hobbies.
- (i) Fluctuations in sleeping, eating habits, weight, appetite, etc.
- (j) Social problems like stealing and the spread of infectious diseases (e.g., AIDS, hepatitis B).
- (k) Damage of the nervous system and **cirrhosis**.
- (l) Use of drugs and alcohol by pregnant woman adversely affects the foetus.
- (m) Misuse of drugs by athletes (e.g., narcotic analgesics, anabolic steroids, diuretics and certain hormones to increase muscle strength and bulk and to promote aggressiveness).

► **Side Effects of Anabolic Steroid in Females**

- (a) Masculinisation
- (b) Mood swings and depression
- (c) Excessive hair growth
- (d) Deepening of voice
- (e) Increased aggressiveness
- (f) Abnormal menstrual cycle
- (g) Enlargement of clitoris

► **Side Effects of Anabolic Steroid in Males**

- (a) Acne
- (b) Mood swings and depression
- (c) Increased aggressiveness
- (d) Reduced testicles
- (e) Decreased sperm
- (f) Kidney and liver dysfunction
- (g) Breast enlargement
- (h) Premature baldness
- (i) Enlargement of the prostate gland

► **Side Effects in the Adolescent, Male and Female**

- Severe facial and body acne.
- Premature closure of the growth centres of the long bones resulting in stunted growth.

► **Prevention and Control**

- (a) Avoid undue peer pressure.
- (b) Education and counselling.
- (c) Seeking help from parents and peers.
- (d) Looking for danger signs.
- (e) Seeking professional and medical help.
- (f) Psychologists and psychiatrists.
- (g) De-addiction and rehabilitation programs.

Example 2

- Q. A team of students are preparing to participate in the interschool sports meet. During a practice session you find some vials with labels of certain cannabinoids.
- (i) Will you report to the authorities ? Why ?
 - (ii) Name a plant from which such chemicals are obtained.
 - (iii) Write the effect of these chemicals on human body.

- Sol. (i) Yes, I would report the matter to the authorities because vials might have been abused by the sports persons. Moreover, cannabinoids are classified under drugs and drug abuse is an illegal practice.
- (ii) Cannabinoids can be obtained from a plant called *Cannabis sativa*.
 - (iii) These chemicals increase athletic performance of the sports persons but they have many harmful side effects. The cannabinoids bind to cannabinoid receptors present in the brain and affect the cardiovascular system.

CHAPTER-8

MICROBES IN HUMAN WELFARE

Topic-1

Microbes and their Uses

Concepts Covered • *Microbes in Daily Life, household products, Industrial Products Sewage Treatment and Biogas Production*



Revision Notes

- ▶ **Microbes in Daily Life**
 - Microbes are the major components of the biological system on the Earth.
 - They are very minute organisms that cannot be seen with the naked eyes but are viewed under the microscope.
 - Microbes are present everywhere such as in soil, water, air, inside our body and bodies of animals and plants.
 - They are also present where no other life-form could exist such as deep inside the geysers (thermal vents) where the temperature may be as high as 100°C, deep in the soil, under the layers of snow, several metres thick and in highly acidic environments.
 - Microbes are diverse—protozoa, bacteria, fungi and microscopic plants.
 - Viruses, viroids and also prions are not considered as living entities, even though, they are considered as infectious agents.
 - Microbes like bacteria and many fungi can be grown on nutritive media to form colonies, that can be seen with the naked eyes. Such cultures are useful in studies on micro-organisms.
 - Some microbes are harmful to mankind, causing several infectious diseases but some are important in many ways for human welfare.
- ▶ **Microbes in household products.**
 1. **Lactobacillus or Lactic Acid Bacteria (LAB)**
 - It converts milk into curd.
 - It produces lactic acid that coagulates and partially digests the milk protein casein.
 - A small amount of curd containing LAB converts fresh milk into curd.
 - It also increases vitamin B₁₂.
 - In the stomach, it inhibits the growth of pathogens.
 2. **Bacterial Fermentation (Anaerobic Respiration)**
 - The dough which is formed by the fermentative activity of bacteria is used to make foods such as *dosa, idli*, etc.
 - The puffed-up appearance of dough is due to the production of CO₂ gas.
 - 'Toddy' is an alcoholic drink, made by fermenting flower sap from palms by bacteria.
 - Microbes are used to ferment fish, soyabean and bamboo-shoots to make foods.
 - Microbes are used to produce cheese, which differ in flavour, taste and texture e.g., Large holes in 'Swiss cheese' are due to the production of a large amount of CO₂ by *Propionibacterium shermanii* (a bacterium).
 - 'Roquefort cheese' is ripened by growing a specific fungus (*Penicillium roqueforti*) on them that gives them a particular flavour.
 3. **Baker's Yeast (*Saccharomyces cerevisiae*):**
 - It is used to make bread by fermenting dough.
- ▶ **Microbes in Industrial Products**
 - The large scale production of beverages, antibiotics etc., on an industrial scale, requires growing microbes in very large vessels called fermentors or bioreactors.
 1. **Fermented Beverages**
 - *Saccharomyces cerevisiae* (Brewer's yeast) is used in the production of beverages by fermenting malted cereals and fruit juices to produce ethanol.
 - Wine and beer are produced without distillation.
 - Whisky, Brandy and Rum are produced by distillation of the fermented broth.
 2. **Antibiotics**
 - The chemical substances produced by some microbes that can kill or inhibit the growth of other disease-causing microbes.
 - They are used to treat plague, whooping cough, diphtheria, leprosy and many other infectious diseases.



Key Words

Antibiotic: They are the medicines, which prevent the growth and multiplication of bacteria in animal or human body which are harmful to them.

Immunosuppressive agent: It is an agent that decreases the body's immune response.

► Penicillin

- First antibiotic discovered by Alexander Fleming in 1929.
- He observed that a mould (*Penicillium notatum*) growing in unwashed culture plates around which *Staphylococci* could not grow.
- He extracted penicillin from it.
- Ernst Chain and Howard Florey established its full potential as an effective **antibiotic**.
- Fleming, Chain and Florey were awarded Nobel Prize (1945).

3. Chemicals, enzymes and other bioactive molecules

(a) Organic Acids: e.g.,

- *Aspergillus niger* (a fungus): Citric acid
- *Acetobacter aceti* (a bacterium): Acetic acid
- *Clostridium butylicum* (a bacterium): Butyric acid
- *Lactobacillus* (a bacterium): Lactic acid

(b) Alcohol:

- Yeast (*Saccharomyces cerevisiae*) is used to produce ethanol.

(c) Enzymes:

- **Lipases:** Used in detergent formulations. Help to remove oily stains from the laundry.
- **Pectinases and Proteases:** To clarify bottled juices.
- **Streptokinase:** Produced by *Streptococcus*. Used as a 'clot buster' to remove clots from the blood vessels of patients who have a myocardial infarction.

(d) Cyclosporin A:

- It is produced by *Trichoderma polysporum* (fungus).
- It is used as an **immunosuppressive agent** in organ-transplant patients.

(e) Statins:

- It is produced by *Monascus purpureus* (an yeast).
- It is used as a blood-cholesterol lowering agent.
- It inhibits the enzymes responsible for the synthesis of cholesterol.

► Microbes in Sewage Treatment

- Sewage (municipal waste-water) contains a large amount of human excreta, organic matter and microbes.
- Sewage is treated in Sewage Treatment Plants (STPs) to make it less polluting. It includes stages namely: primary treatment and secondary treatment.

(a) Primary Treatment

- It is a physical treatment.
- It involves the physical removal of large and small particles from sewage. It includes:
 - Removal of floating debris by sequential filtration.
 - Removal of the grit (soil and pebbles) by sedimentation.
 - All solids that settle form the primary sludge and the supernatant forms the primary effluent.
 - The effluent is taken for secondary treatments.

(b) Secondary treatment (Biological treatment)

- Primary effluent is passed into large aeration tanks and constantly agitated.
- This allows vigorous growth of useful aerobic microbes into flocs (masses of bacteria associated with fungal filaments to form mesh-like structures).
- These microbes consume the major part of the organic matter in the effluent.
- This reduces the BOD (Biochemical Oxygen Demand) of the effluent.
- The effluent is then passed into a settling tank where the bacterial 'flocs' are allowed to sediment. This sediment is called 'activated sludge'.
- A small part of the activated sludge is pumped back into the aeration tank to serve as the inoculum.
- The remaining major part of the sludge is pumped into large tanks called anaerobic **sludge digesters**.
- Here, some anaerobic bacteria digest the bacteria and fungi in the sludge by producing gases like CH₄, H₂S and CO₂. These gases form the biogas.
- The effluent from the secondary treatment plant is released into natural water bodies like rivers and streams.
- The Ministry of Environment and Forests has initiated the **Ganga Action Plan** and **Yamuna Action Plan** to save rivers from water pollution.

Biological Oxygen Demand (BOD)

- BOD represents the amount of dissolved oxygen required for the complete oxidation of all the organic matter present in one litre of water by bacteria at 20°C.
- BOD measures the amount of organic matter present in water by measuring the rate of O₂ taken up by microbes.
- Higher BOD indicates that the water is highly polluted by organic matter. A lower value of BOD means the water is less polluted or normal.

**Key Words**

Inflammable gases: Gases which burn in the presence of oxidant when provided with source of ignition.

Methanogens: Microorganisms that produce methane along with O₂ and H₂ under anaerobic conditions.

Microbes in Production of Biogas

- Biogas is a mixture of **inflammable gases** (mainly CH₄) produced by the microbial activity.
- Biogas is used for cooking and lighting.
- **Methanogens** grow anaerobically on cellulosic material and produce CH₄ gas e.g., *Methanobacterium*.
- *Methanobacterium* is found in the anaerobic sludge and rumen of cattle (for cellulose digestion).
- The dung of cattle (gobar) is rich in these bacteria.
- Dung can be used for the generation of biogas (Gobar gas).

**Key Fact**

There are more bacteria in a person's mouth than the entire population of the world.

A Biogas plant consists of

- A concrete tank
 - Floating cover
 - An outlet
- The concrete tank (10-15 feet deep) collects bio-wastes and slurry of dung.
 - A floating cover is placed over the slurry, which keeps on rising as the biogas is produced.
 - There is an outlet which is connected to a pipe to supply biogas to nearby houses.
 - Used slurry is removed through another outlet and can be used as a fertilizer.
 - Indian Agricultural Research Institute (IARI), Khadi and Village Industries Commission (KVIC) developed the technology of biogas production in India.

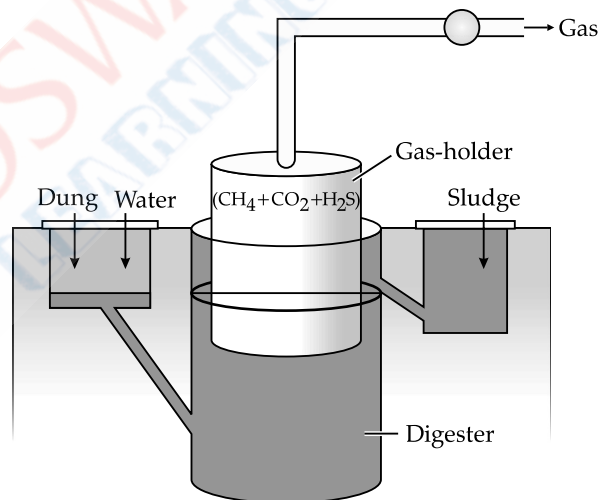

Fig. 8.1 A Biogas plant

**Mnemonics**

1. Concept: Organic acid bacteria

Mnemonic: All Answers Clearly Labelled

Interpretations: *Aspergillus niger*, *Acetobacter aceti*, *Clostridium butylicum*, *Lactobacillus*.

Example 1

Q. What are methanogens ? How do they help to generate biogas ?

Sol. Methanogens are the bacteria which grow anaerobically on cellulosic material and produce large amount of methane along with CO₂ and H₂S.

(i) Present in cattle (rumen) a part of stomach.

(ii) They help in:

(a) Breaking down of cellulose present in food of cattle.

(b) Nutrition of animal for digestion of cellulose.

The excreta of cattle is rich in these bacteria (methanogens) and therefore can be used for generation of biogas.

Topic-2

Microbes as Biocontrol Agents and Bio-Fertilisers

Concepts Covered • *Microbes as biocontrol agents, biofertilisers.*



Revision Notes

▶ Biocontrol

- It is the application of biological methods for controlling plant diseases and pests.

▶ Chemical Pesticides and Insecticides

- These are toxic and harmful to all organisms including human beings and cause pollution.
- Chemical pesticides kills both useful and harmful life forms.
- Weedicides used to eliminate weeds cause soil pollution.

▶ Microbial biocontrol agents

(a) *Bacillus thuringiensis* (Bt):

- This is to control the butterfly caterpillar. These are available in sachets as dried spores which are mixed with water and sprayed on vulnerable plants such as *Brassica* and fruit trees, where these are eaten by the insect larvae. In the gut of the larvae, the toxin is released and the larvae get killed. Scientists have introduced *B. thuringiensis* toxin genes into plants e.g., Bt cotton.



Key Words

Pesticides are the substances which are used to kill harmful pests from the soil.

Insecticides are the substances which are formulated to kill one or more species of insects.

Symbiotic: The relationship involving interaction between two different organisms living in close physical association.

(b) *Trichoderma* sp. (Fungus):

- These are free living species that are seen in the root ecosystem. They are effective biocontrol agents of several plant pathogens.

(c) *Baculoviruses* (Especially genus *Nucleopolyhedrovirus*):

- It attacks insects and other arthropods. These are suitable for species-specific, narrow spectrum insecticidal applications. This is desirable in the IPM program to conserve beneficial insects.

▶ Microbes as Biofertilisers

- Biofertilizers are the micro-organisms that enrich the nutrient quality of the soil. e.g., Bacteria, fungi, cyanobacteria etc.

▶ *Rhizobium*

- It is a **symbiotic** bacteria found in root nodules of leguminous plants that fixes atmospheric N₂.
- Free-living bacteria in the soil such as *Azospirillum* and *Azotobacter* enrich the nitrogen content of the soil.

▶ *Mycorrhiza*

- It is a symbiotic association of fungi (e.g., the genus of *Glomus*) with the roots of higher plants.
- The fungus gets food for the plant.
- The fungal symbiont help to absorb phosphorus from soil and passes it to the plant, give resistance to root-borne pathogens, tolerance to salinity and drought and also gives an overall increase in plant growth and development.

▶ Cyanobacteria (Blue-green algae):

- They are autotrophic microbes that fixes atmospheric nitrogen e.g., *Anabaena*, *Nostoc*, *Oscillatoria*, etc.
- In paddy fields, Cyanobacteria serve as an important biofertilizers.
- It also adds organic matter to the soil and increases its fertility.



Mnemonics

1. Concept: Microbial Biocontrol agents

Mnemonic: Back To Back

Interpretation: *Bacillus thuringiensis*, *Trichoderma sp.*,
Baculoviruses.

2. Concept: Free living bacteria

Mnemonic: Almond's Apple

Interpretation: *Azospirillum*, *Azotobacter*

Example 2

Q. (i) How do organic farmers control pests ? Give two examples.

(ii) State the difference in their approach from that of conventional pest control methods.

Sol. (i) Organic farmers control pests by utilising natural predation instead of introducing or applying chemicals.

Microbial biocontrol agents are the species – specific pesticides.

The examples include:

(a) *Bacillus thuringiensis*: This is a bacterium which produces a toxin that specifically kills insect larvae of cotton bollworm such as lepidopterans, coleopterans and dipterans leaving aside all other non-targeted organisms.

(b) It is free living fungus and works as *Trichoderma sp.*, a bio-control agent against several plants pathogens.

(ii) **The difference between the organic farming method and conventional pest control methods are:**

(a) Conventional pest control methods use chemicals. They are non-specific, cause harm to non target beneficial organisms and pose problems like environmental pollution and biological magnification, whereas organic farmers control pest by biocontrol agents. They are specific, do not harm non target organism and do not cause pollution.

(b) As compared to conventional pest control methods, organic farmers do not try to completely get rid of pests but keep them at manageable levels. They believe that complete eradication of pests is not beneficial and has certain adverse effects. It leads to death of those beneficial creatures that are dependent on them for food.

UNIT – IX: BIOTECHNOLOGY AND ITS APPLICATIONS

CHAPTER-9

BIOTECHNOLOGY: PRINCIPLES AND PROCESSES

Topic-1

Principles of Biotechnology and Tools of Recombinant DNA Technology

Concepts Covered • *Biotechnology, Principles of Biotechnology, Tools of Recombinant DNA technology.*



Revision Notes

➤ Introduction

- **Biotechnology** deals with the techniques of using live organisms or their enzymes for products and processes useful to humans.
- The term biotechnology was given by Karl Ereky (1919).
- The **European Federation of Biotechnology (EFB)** defines Biotechnology as 'the integration of natural science and organisms, cells, parts thereof, and molecular analogues for products and services'.

➤ Biotechnology deals with:

- Microbe-mediated processes (making curd, bread, wine, etc.)
- *In vitro* fertilisation ('test-tube' baby programme).
- Synthesis and using of a gene.
- Preparation of a DNA vaccine.
- Correcting a defective gene.

► Principles of Biotechnology

• The two core techniques of modern biotechnology are:

- Genetic engineering:** The technique in which the genetic material (DNA and RNA) is chemically altered and introduced into host organisms to change the phenotype is known as genetic engineering.
 - Maintenance of sterile ambience:** It is necessary for chemical engineering processes to grow only the desired microbe / eukaryotic cell in large quantities for the manufacture of antibiotics, vaccines, enzymes, etc.
- Traditional hybridisation techniques lead to the inclusion and multiplication of undesirable genes along with desired genes.
 - Genetic engineering helps to isolate and introduce only desirable genes into the target organism.
 - A piece of DNA is not only able to multiply itself in the progeny cells of the organism, but, when it gets integrated into the recipient **genome**, it multiplies and inherits along with the host DNA.
 - First recombinant DNA was emerged from the possibility of linking a gene of antibiotic resistance with a native plasmid of *Salmonella typhimurium*. The plasmid is an autonomously replicating circular extra-chromosomal DNA.
 - Stanley Cohen and Herbert Boyer (1972) constructed the first recombinant DNA. They isolated the antibiotic resistance gene by cutting out a piece of DNA from a **plasmid**.

► Steps in Genetically Modifying an Organism

• There are three basic steps in genetically modifying an organism:

- Identification of DNA with desirable genes.
- Introduction of the identified DNA into the host.
- Maintenance of introduced DNA in the host and transfer of the DNA to its progeny.

► Tools of Recombinant DNA technology

1. Restriction Enzymes ('molecular scissors')

- The restriction enzymes are called molecular scissors and are responsible for cutting DNA.
- In 1963, two enzymes responsible for restricting the growth of bacteriophage in *E. coli* were isolated. One of these added methyl groups to DNA. The other (restriction endonuclease) cut DNA.
- The first restriction endonuclease is Hind II. Isolated by Smith, Wilcox and Kelley (1968) from *Haemophilus influenzae* bacterium. It always cuts DNA molecules at a particular point by recognizing a specific sequence of six base pairs. This is known as the recognition sequence for Hind II.
- Today more than 900 restriction enzymes have been isolated from over 230 strains of bacteria.

► Naming of the restriction enzymes

- First letter indicates genus and the second two letters indicate species of the **prokaryotic cell** from which they were isolated e.g., EcoRI comes from *E. coli* RY 13, where R = the strain, Roman numbers = the order in which the enzymes were isolated from that strain of bacteria.
- Restriction enzymes belong to a class of enzymes called **nucleases**.
- The nucleases include **exonucleases** and **endonucleases**.



Key Words

Genome : It is an entire set of DNA instructions found in a cell.

Plasmid : It is a small, circular, double stranded ANA molecule; It naturally exist in bacterial cells and in some eukaryotes.

Prokaryotic cell : Single-celled, lack true nucleus (i.e., nucleus is not bounded by a true nuclear membrane).

Palindrome : A DNA or RNA sequence that reads exactly the same in both directions.

(i) Exonucleases

- They remove nucleotides from the ends of the DNA.

(ii) Endonucleases

- They cut at specific positions within the DNA.
- Each restriction endonuclease can bind to a specific recognition sequence of the DNA and cut each of the two strands at specific points in their sugar-phosphate backbones.
- Each restriction endonuclease recognizes a specific palindromic nucleotide sequence in the DNA.
- The palindrome in DNA is a sequence of base pairs that read the same on the two strands in the 5' → 3' direction and in 3' → 5' direction. e.g.,

5' — GAATC — 3'

3' — CTTAAG — 5'

- Restriction enzymes cut the strand a little away from the centre of the **palindrome** sites but between the same two bases on the opposite strands. This leaves single-stranded overhanging stretches at the ends. They are called sticky ends.

- They form H-bonds with their complementary cut counterparts. This stickiness facilitates the action of the enzyme **DNA ligase**.
- When cut by the same restriction enzyme, the resultant DNA fragments have the same kind of sticky-ends and these are joined together by the enzyme DNA ligases.

► **Separation and isolation of DNA fragments:**

- DNA fragments formed by restriction endonuclease can be separated by a technique called **Gel electrophoresis**.
- DNA fragments are negatively charged. So, they can be separated by moving them towards the anode under the influence of an electric field through a medium / matrix such as **agarose** (which is a natural polymer of D-galactose and 3, 6 anhydro L-galactose and is extracted from sea weeds).
- The DNA fragments separate (resolve) according to their size through the sieving effect provided by the agarose gel.
- The smaller sized fragments move farther.
- The separated DNA fragments can be visualized after staining the DNA with **ethidium bromide** followed by exposure to UV radiation. Bright orange coloured DNA bands can be seen.
- The separated DNA bands are cut out from agarose gel and extracted from the gel piece. This step is called elution.
- These purified DNA fragments are used in constructing recombinant DNA by joining them with cloning vectors.

2. **Cloning Vectors**

- These are the DNA molecules that can carry a foreign DNA segment and replicate inside the host cells e.g., **plasmids** (circular extra-chromosomal DNA of bacteria) and **bacteriophages**.
- Bacteriophages (high number per cell) have very high copy numbers of their genome within the bacterial cells.
- Some plasmids have only 1-2 copies per cell. Others may have 15-100 copies per cell.
- When the cloning vectors are multiplied in the host the linked piece of DNA is also multiplied to the numbers equal to the copy number of the vectors.



Key Fact

Humans shares about 98% of their genes with chimpanzees, 92% with mice, 18% with (*E. coli*) bacteria.

► **Features of cloning vector:**

(a) **Origin of replication (*ori*)**

- This is a DNA sequence from where **replication** starts. A piece of DNA linked to *ori* site can replicate within the host cells. This also controls the copy number of the linked DNA. So, to get many copies of the target DNA, it should be cloned in a vector whose origin support high copy number.

(b) **Selectable marker (marker gene)**

- It helps to select the transformants and eliminate the non-transformants.
- **Transformation** is a procedure in which a piece of DNA is introduced in a host bacterium.
- Selectable markers of *E. coli* include the genes encoding resistance to antibiotics like ampicillin, chloramphenicol, tetracycline or kanamycin, etc.
- The normal *E. coli* cells do not carry resistance against any of these antibiotics.

(c) **Cloning sites**

- To link the alien DNA, the vector needs very few recognition sites for restriction enzymes.
- Presence of more than one recognition site generates several fragments, which complicates the gene cloning.
- The ligation of alien DNA is carried out at a restriction site present in one of the two **antibiotic resistance genes**. e.g., ligation of a foreign DNA at the BamHI site of the tetracycline resistance gene in the **vector pBR322**.
- The recombinant plasmids lose tetracycline resistance due to insertion of foreign DNA. But, they can be selected out from non-recombinant ones by plating the transformants on **ampicillin** containing medium.
- Then, these transformants are transferred to a **tetracycline** medium.
- The recombinants grow in ampicillin medium but not on tetracycline medium. But, non-recombinants will grow on the medium containing both the antibiotics.

- In this case, one antibiotic resistance gene helps to select the transformants, whereas the other antibiotic resistance gene gets inactivated due to the insertion of alien DNA and helps in the selection of recombinants.
- Selection of recombinants due to the inactivation of antibiotics requires simultaneous plating on two plates having different antibiotics.
- Therefore, alternative selectable markers have developed to differentiate recombinants from non-recombinants based on their ability to produce colour in the presence of a chromogenic substrate.
- A recombinant DNA is inserted within the coding sequence of an enzyme, β -galactosidase. So, the enzyme is inactivated. It is called **insertional inactivation**. Such colonies do not produce any colour. These are identified as recombinant colonies.
- If the plasmid in bacteria do not have any insert it gives blue coloured colonies in presence of chromogenic substrate.

(d) Vectors for cloning genes in plants and animals

- Genetic tools of some pathogens can be transformed into useful vectors for delivering genes to plants and animals. e.g., *Agrobacterium tumefaciens* (a pathogen of many dicot plants) can deliver a piece of DNA (T-DNA) to transform normal plant cells into a tumor.
- These tumor cells produce the chemicals required by the pathogen.
- The **tumor-inducing (Ti) plasmid** of *A. tumefaciens* is modified into a cloning vector which is not pathogenic to the plants but can use the mechanisms to deliver genes of interest into plants.
- Retroviruses in animals can transform normal cells into **cancerous** cells. So, they are used to deliver desirable genes into animal cells.

3. Competent Host (For Transformation with Recombinant DNA)

- Competent cells are capable of uptaking DNA from the surrounding. For the process of transformation, bacterial cells are made competent, so that DNA can enter the cells.
- DNA is a hydrophilic molecule. So it cannot pass through cell membranes.
- To avoid this problem, bacterial cells are treated with a specific concentration of a divalent cations (e.g., calcium), so as to increase the pore size in the cell wall.
- So, DNA enters the bacterium through pores in the cell wall. Such cells are incubated with recombinant DNA on ice.
- They are then placed briefly at 42°C (heat shock) and then put them back on ice. This enables the bacteria to take up the recombinant DNA.

► **Other methods to introduce alien DNA into host cells:**

- Micro-injection:** In this, recombinant DNA is directly injected into the nucleus of an animal cell.
- Biolistics (gene gun) method:** In this, cells are bombarded with high-velocity micro-particles of gold or tungsten coated with DNA. This method is suitable for plants.
- 'Disarmed pathogen' vectors:** These vectors, when infect the cell, transfer the recombinant DNA into the host.

IMPORTANT DIAGRAMS.

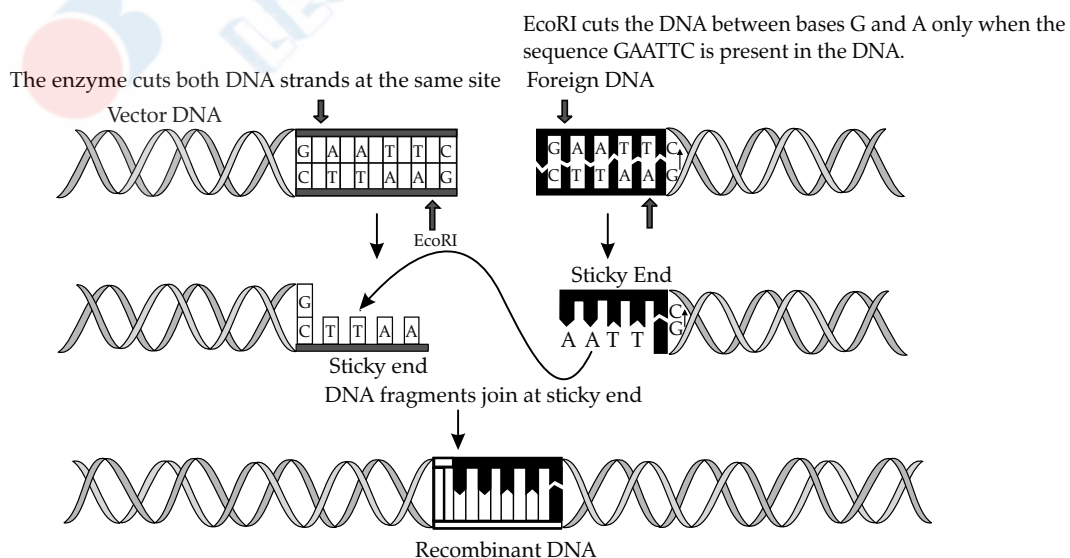

Fig 9.1: Steps in formation of recombinant DNA by action of restriction endonuclease enzyme- EcoRI.

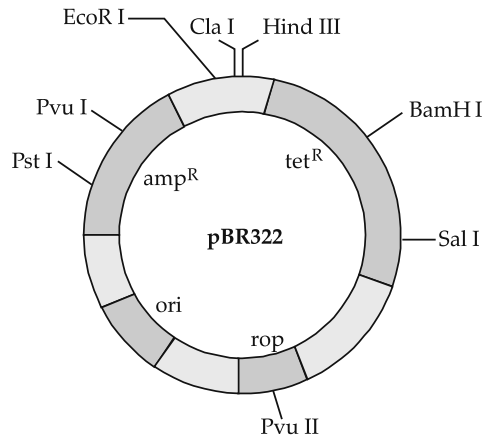

Fig 9.2: Cloning vector pBR322

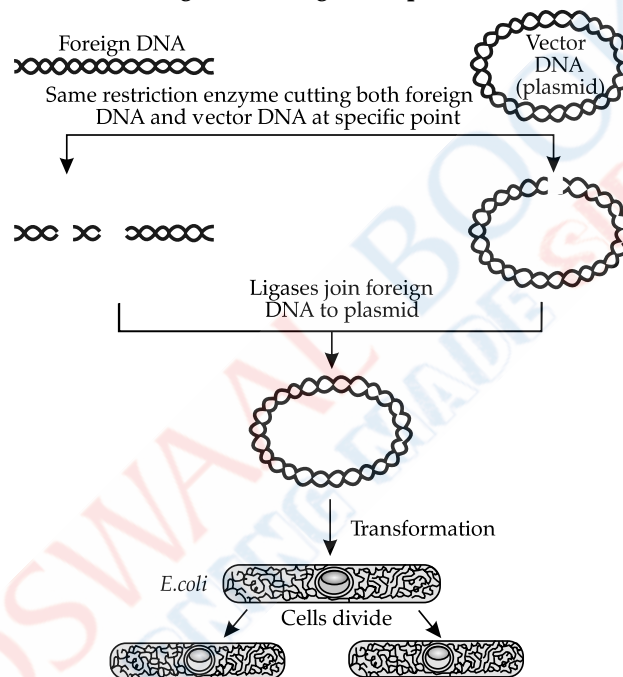

Fig 9.3: Diagrammatic representation of recombinant-DNA technology



Mnemonics

1. Concept: Important tools in Biotechnology.

Mnemonics: HELina Gyi Gaate Gate: Speed of 40 Hilte-dulte Gun Gunaate by Road Highway

Interpretations: Tools	:	Characters
Heat Shock	:	Sudden temperature raised to 40°C
Electroporation	:	High voltage pulse
Liposomes	:	Genes to cells in vivo
Gene gun	:	Gold particles
Genetic marker	:	R plasmid
Gene synthesis	:	Hormone somatostatin

2. Concept: Animal Clones

Mnemonic: No Due Names : Put Some Almonds

Interpretation: Clone name	:	Species
Noori	:	Pashmina Goat
Dolly	:	Sheep
Noah	:	Asian Gaur

Example 1

Q. Describe the formation of recombinant DNA by the action of EcoRI.

Sol. The formation of recombinant DNA by the action of EcoRI are as follows:

- Each restriction endonuclease recognizes a specific palindromic nucleotide sequences in the DNA.
- It cuts the strand of DNA a little away from the centre of the palindrome sites, but between the

same two bases on the opposite strands. This leaves single stranded portions at the ends.

- There are overhanging stretches called sticky ends on each strand.
- These are named so because they form hydrogen bonds with their complementary cut counterparts.
- This stickiness of the ends facilitates the action of the enzyme DNA ligase.

Topic-2

Process of Recombinant DNA Technology

Concepts Covered • Processes of rDNA technology • Bioreactors



Revision Notes

► Isolation of the Genetic Material (DNA)

- To get pure DNA (free from other macro-molecules), the bacterial cells / plant or animal tissue are treated with enzymes such as **lysozyme** (bacteria), **cellulase** (plant cells), **chitinase** (fungus), etc.
- The cell is broken to release DNA along with other macromolecules (RNA, proteins, polysaccharides and lipids).
- Genes (DNA) are intertwined with proteins such as **histones**.
- RNA is removed by treating with **ribonuclease**.
- Proteins are removed by treatment with **protease**.
- Other molecules are removed by appropriate treatments.
- When chilled ethanol is added, purified DNA precipitates out as a collection of fine threads in the suspension.

► Cutting of DNA at Specific Locations

- Restriction enzyme digestions are performed by incubating purified DNA with the restriction enzyme, at the optimal conditions.

► Isolation of derived DNA fragments.

- Agarose gel electrophoresis** is employed to check the progression of a restriction enzyme digestion. As DNA is negatively charged, it moves towards the anode. The process is repeated with the vector DNA also.
- After cutting the source DNA and the vector DNA, the cutout gene (DNA segment) of interest from the source DNA and the cut vector are mixed and ligase is added.
- This creates recombinant DNA.

► Amplification of Gene of Interest Using PCR

- Polymerase Chain Reaction (PCR)** is the synthesis of multiple copies of the gene of interest *in vitro* using two sets of **primers** and the enzyme **DNA polymerase**.
- The technique was developed by Kary Mullis in 1985 and for this, he was awarded the Nobel Prize in 1993.
- DNA polymerase enzyme joins the nucleotides
- Most commonly enzyme is *Taq* polymerase



Key Fact

Polymerase Chain Reaction (PCR) can be used to identify diseases. This technology was used during SARS epidemic, 2003.

► Insertion of Recombinant DNA into the Host Cell / organism

- There are several methods of introducing the ligated DNA into recipient cells.
- Recipient cells take up DNA present in its surrounding.

- If a recombinant DNA bearing **ampicillin resistant gene** (a selectable marker gene) is transferred into *E. coli* cells, the host cells become ampicillin-resistant cells.
- If the transformed cells are spread on agar plates containing ampicillin, only transformants will grow, non transformed recipient cells will die.



Key Word

Histone: A type of protein found in chromosomes. Histones bind to DNA, help give shape to chromosomes and help control the activity of genes.

► Obtaining the Foreign Gene Product

- The ultimate aim of recombinant DNA technology is to produce a desirable protein.
- The foreign gene gets expressed under appropriate conditions.
- If a protein-encoding gene is expressed in a heterologous host, it is called a **recombinant protein**.
- The cells with foreign genes may be grown on a small scale in the laboratory.
- The cultures may be used to extract the desired protein and purified using different separation techniques.
- The cells can also be multiplied on large scale in a continuous culture system.
- Here, the used medium is drained out from one side while the fresh medium is added from the other side.
- It maintains the cells more physiologically active and so produces a larger biomass leading to higher yields of the desired protein.

► Downstream Processing: All the processes to which the product is subjected to before being marketed as a final and finished product are called as downstream processing.

- It includes a series of processes such as separation and purification of products after the biosynthetic stage.
- The product is formulated with suitable preservatives.
- Such formulation undergoes through clinical trials as in the case of drugs.
- Strict quality control testing for each product is also required.
- The downstream processing and quality control testing vary from product to product.

► Bioreactors

- To produce large quantities of products, the bioreactors are used where large volumes (100-1000 litres) of culture can be processed.
- Bioreactors are the vessels in which raw materials are biologically converted into specific products, enzymes etc., using microbial plant, animal or human cells.
- A bioreactor provides the optimal growth conditions (temperature, pH, substrate, salts, vitamins, oxygen) for achieving the desired product.
- There are two types of bioreactors namely,
 - (a) Simple stirred-tank bioreactor
 - (b) Sparged stirred-tank bioreactor
- The most commonly used bioreactors are of stirring type.

► Stirred-tank Reactor

- It is usually cylindrical or with a curved base to facilitate the proper mixing of the reacting contents.
- The stirrer facilitates even mixing and oxygen availability throughout the bioreactor.
- Alternatively, air can be bubbled through the reactor.
- The bioreactor has
 - (a) An agitator system.
 - (b) An oxygen delivery system.
 - (c) A foam control system.
 - (d) A temperature control system.
 - (e) pH control system.
 - (f) Sampling ports (for periodic withdrawal of the culture).
 - (g) The contents are mixed by stirrer. This makes the oxygen available throughout the bioreactor.

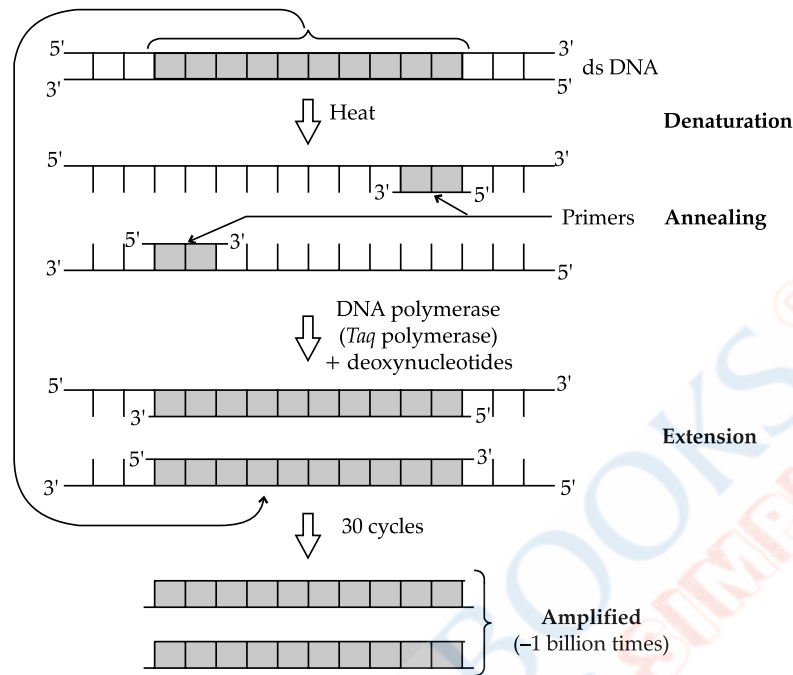
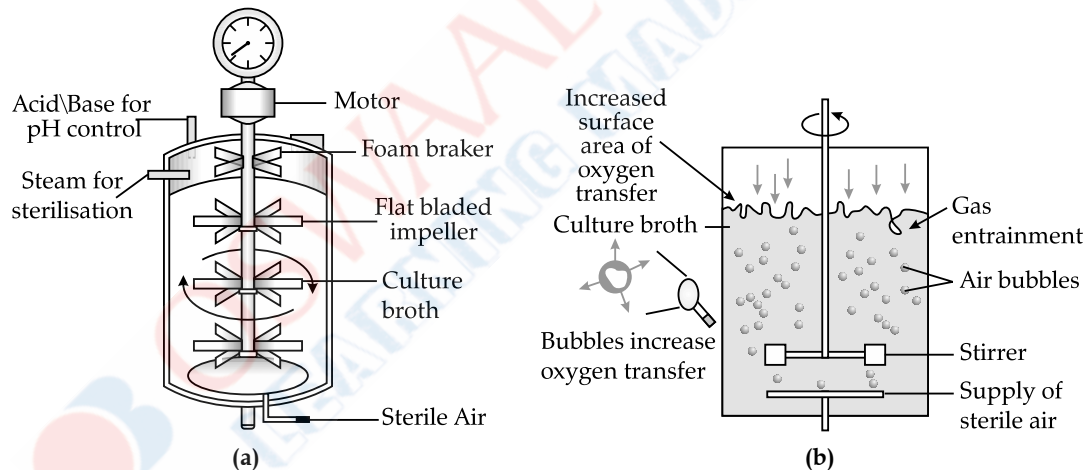
IMPORTANT DIAGRAMS:**Fig. 9.4: Polymerase Chain reaction****Fig. 9.5: Bioreactors- (a) Simple stirred-tank Bioreactor, (b) Sparged stirred-tank bioreactor****Example 2**

Q. Write the steps you would suggest to be undertaken to obtain a foreign-gene-product.

Sol. The steps to be undertaken to obtain a foreign-gene-product are as follows:

- Insertion of a piece of desired DNA into cloning vector to get recombinant DNA.
- Transfer of recombinant DNA into a host cell. (Plant or animal or bacterial cell).
- The alien DNA will get multiplied.
- After the cloning of gene of interest, optimised conditions are provided to the culture to induce the expression of the target gene.
- Extraction of the desired product.
- Purification of desired products by using different separation technique.

CHAPTER-10

BIOTECHNOLOGY AND ITS APPLICATIONS

Topic-1

Applications of Biotechnology in Agriculture and Medicine

Concepts Covered • Applications of Biotechnology, Stem cell technology, Gene therapy, Molecular diagnosis.



Revision Notes

► Applications of Biotechnology

- Biotechnology essentially deals with industrial-scale production of biopharmaceuticals using genetically modified microbes, fungi, plants and animals.
- The applications of biotechnology include therapeutics, diagnostics, and genetically modified crops for agriculture, processed food, **bioremediation**, waste treatment and energy production.
- **Three critical research areas of biotechnology are :**
 - (a) Providing the best catalyst in the form of an improved organism usually a microbe or pure enzyme.
 - (b) Creating optimal conditions through engineering for a catalyst to act.
 - (c) Downstream processing technologies to purify the protein / organic compound.



Key Word

Bioremediation : Branch of biotechnology which use living organisms, like microbes and bacteria to remove pollutants, contaminants, etc. from soil, water, etc.

► Biotechnological Applications in Agriculture :

- **Three options for increasing food production are are :**
 - (a) Agro-chemical based agriculture.
 - (b) Organic agriculture.
 - (c) Genetically engineered crop-based agriculture.
- The Green Revolution succeeded in tripling the food supply.
- Increased yields have partly been due to the use of improved crop varieties, but mainly due to the use of better management practices and use of agrochemicals (fertilisers and pesticides).
- Genetically Modified Organisms (GMO) or transgenic organisms are the plants, bacteria, fungi and animals whose genes are altered by manipulation.

► Advantages of Genetic Modification in Plants

- (a) It makes crops more tolerant to abiotic stresses (cold, drought, salt, heat, etc).
- (b) It helps to reduce post-harvest losses.
- (c) It increases the efficiency of mineral usage by plants (this prevents early exhaustion of fertility of soil).
- (d) It enhances the nutritional value of food e.g., Vitamin 'A' enriched rice.
- (e) GM is used to create tailor-made plants to supply alternative resources to industries in the form of starch, fuels and pharmaceuticals.



Key Fact

Some of the genetic material that make our DNA is not of the human origin. Viruses and bacteria have inserted some of it in a process called horizontal DNA Transfer.

► Pest Resistant Plants

- Pest Resistant Plants reduce the use of chemical pesticide.
- It reduces the need for insecticides e.g., Bt cotton, Bt corn, rice, tomato, potato, soyabean, etc.

► Bt Cotton

- Some strains of *Bacillus thuringiensis* produce proteins that kill insects like coleopterans (beetles), lepidopterans (tobacco, budworm, armyworm) and dipterans (flies, mosquitoes).

- *B. thuringiensis* forms a toxic insecticidal protein (Bt toxin) crystal during a particular phase of their growth. It does not kill the *Bacillus* as it exists as inactive protoxins.
- When an insect ingests the inactive toxin, it is converted into an active toxin due to the alkaline pH of the gut which solubilises the crystals.
- The toxin binds to the surface of midgut epithelial cells and create pores.
- It causes cells to swell and undergo lysis and ultimately leading to the death of the insect.
- Bt toxin genes were isolated from *B. thuringiensis* and incorporated into crop plants such as cotton.
- Most Bt toxins are insect-group specific.
- The toxin is coded by a gene named cry e.g., the proteins encoded by the genes *cryI*Ac and *cryII*Ab control the cotton bollworms and that of *cryI* Ab controls corn borer.

► Biotechnological Applications in Medicine

- The recombinant DNA technology helps for the mass production of safe and more effective **therapeutic** drugs.
- The recombinant therapeutics does not induce unwanted immunological responses as it is common in the case of similar products isolated from non-human sources.
- At present, about 30 recombinant therapeutics have been approved for human use in the world including India.
- In India, 12 of these are presently being marketed.

► Genetically Engineered Insulin

- The management of adult-onset diabetes is possible by taking insulin at regular time intervals.
- Now, it is possible to produce human insulin using bacteria.
- Insulin from the pancreas of animals (cattle and pigs) causes allergy or other types of reactions to the foreign protein.
- Insulin consists of two short polypeptide chains (chain A and chain B) that are linked together by disulphide bridges.
- In mammals, insulin is synthesized as a pro-hormone.
- The pro-hormone needs processing before it becomes a fully mature and functional hormone.
- The pro-hormone contains an extra stretch called the C peptide.
- This is removed during maturation into insulin.
- In 1983, Eli Lilly an American company prepared two DNA sequences corresponding to A and B chains of human insulin and introduced them in plasmids of *E. coli* to produce insulin chains.
- The chains A and B were produced separately, extracted and combined by creating disulfide bonds to form human insulin.



Key Words

Therapeutic : Related to the treatment of disease or disorders by remedial agents or methods.

Pluripotent cell : A cell capable to develop into many different types of cells or tissues in the body.

Malignant disease : In such type of diseases, abnormal cells divide without control and invade nearby cells or blood and lymph.

► Stem Cell Technology :

- Stem cells are undifferentiated or “blank” cells.
- They are special human cells which are capable to develop into many different cell types.
- This can range from muscle cells to brain cells. In some cases, they can also fix damage tissues.
- Stem cells can be obtained from an embryo, or by using a specialized body cells (developed by a technique) which behave like embryonic stem cells. These cells are known as induced **pluripotent** stem cells (IPS cells).
- They are used in treating several clinical problems like : (i) Tissue regeneration. (ii) Damaged myocardium after heart infarction. (iii) Brain after stroke. (iv) Spinal cord after mechanical injury.
- Advantages of stem cells technology : Stem cell technology is a rapidly developing field that combines the efforts of cell biologists, geneticists, and clinicians and offers hope of effective treatment for a variety of **malignant** and **non-malignant** diseases. The regenerative property of stem cell can be used in replacing any organ which is not working or damaged. It can help in studying human growth and cell development. It can be used to test the effects of medicinal drugs and medicine without the use of animals.



Key Word

Non-malignant diseases : In this case, tumors may grow larger but do not spread to other parts of the body.

► Vaccine production:

Vaccines are the substances which protect the human body from various diseases by recognizing and destroying the harmful foreign pathogens. A dead or weakened microbe is used to produce the vaccine.

Generally, there are four types of vaccines which include:

1. **Live attenuated vaccine:** This type of vaccine contains weakened form of viruses. e.g., Rubella, Measles, Mumps etc.

2. **Inactivated vaccines:** These vaccines are made from small pieces of virus or bacteria or from their proteins. e.g., The whooping cough vaccine.
3. **Toxoid vaccines:** These vaccines contain the toxin produced by the bacteria or virus. e.g., Tetanus and diphtheria vaccine.
4. **Biosynthetic vaccines:** These are the man-made vaccines which are produced from the substances or chemicals similar to the pieces of virus or bacteria. e.g., Hepatitis-B.

► **Gene Therapy :**

- It is a method to correct a gene defect diagnosed in a child / embryo.
- Here, genes are inserted into a person's cells and tissues to treat a hereditary disease.
- It compensates for the non-functional gene.
- First clinical gene therapy was given in 1990 to a four year old girl with adenosine deaminase (ADA) deficiency.
- This disorder is caused due to the deletion of the gene for *Adenosine deaminase* (the enzyme crucial for the immune system to function).
- This can be cured by bone marrow transplantation or by enzyme replacement therapy (injection of functional ADA) but these approaches are not completely curative.
- In gene therapy, lymphocytes from the patient's blood are grown in a culture.
- Then, a functional ADA cDNA (using a retroviral vector) is introduced into these lymphocytes.
- They are then returned to the patient.
- This should be periodically repeated as these cells are not immortal.
- However, if the ADA gene (from bone marrow cells) is introduced into cells at the early embryonic stages, it could be a permanent cure.

► **Molecular Diagnosis**

- Recombinant DNA technology, PCR and Enzyme Linked Immunosorbent Assay (ELISA) are some techniques for early diagnosis.
- The presence of a pathogen is normally suspected only when the pathogen has produced a symptom.
- By this time, the concentration of the pathogen will be already very high in the body.
- However, a very low concentration of a bacteria or virus can be detected by amplification of their nucleic acid by PCR.
- PCR is used to detect HIV in suspected AIDS patients.
- It is also used to detect mutations in genes in suspected cancer patients.
- It is a powerful technique to identify many other genetic disorders.
- A single-stranded DNA or RNA, tagged with a radioactive molecule (probe) is allowed to hybridise to its complementary DNA in a clone of cells followed by detection using autoradiography.
- The clone having the mutated gene will hence not appear on the photographic film, because the probe will not have complementarity with the mutated gene.
- ELISA is based on the principle of antigen-antibody interaction.
- Infection by pathogen can be detected by the presence of antigens (proteins, glycoproteins, etc.) or by detecting the antibodies synthesized against the pathogen.

IMPORTANT DIAGRAMS

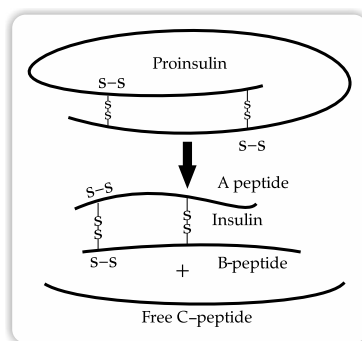

Fig. 10.1 : Genetically Engineered Insulin

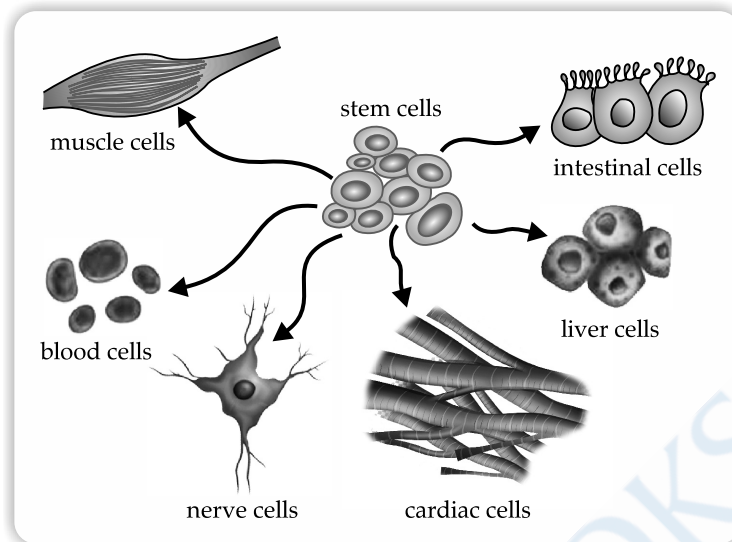

Fig 10.2: Stem cells



Mnemonics

Concept: Achievement through transgenic crops or GM crops.

Mnemonic: Proper Package of Muscular body : Hardwork Can Transform

Interpretations: Achievements of :

	Example
Protein of interest	Hirudin
Production of desired genotype	Cry protein (Crystal protein)
Modification of existing	Transgenic rice (higher content of vitamin A)
Biosynthetic pathway	

Example 1

Q. Why does the insecticidal protein produced by *Bacillus thuringiensis* not kill the bacterium, but kills the cotton bollworm? Explain.

Sol. (i) The Bt toxin protein exist as inactive protoxin and hence does not kill the *Bacillus* but once an insect ingest the inactive toxin, it is converted

into an active form of toxin due to the alkaline pH of the gut which solubilise the crystals.

(ii) The activated toxin binds to the surface of midgut epithelial cells and create pores that cause cell swelling and lysis and eventually cause death of the insect.

Topic-2

Transgenic Animals and Bioethical Issues

Concepts Covered • Transgenic animals, advantages of transgenic animals, Ethical issues.



Revision Notes

➤ Transgenic Animals

- These are the animals whose genome has been altered by the introduction of an extra (foreign) gene by manipulation. e.g., Transgenic rats, rabbits, pigs, sheep, cows and fish.
- Over 95% of all existing transgenic animals are mice.

➤ Advantages or Benefits of Transgenic Animals

- **To study normal physiology and development :**
 - (a) Transgenic animals are used to study how genes are regulated and how they affect the normal body functions and their development.

- (b) For example study of complex factors such as insulin-like growth factor. Genes (from other species) that alter the formation of this factor are introduced and the biological effects are studied. This gives information about the biological role of the factor in the body.
- **To Study the contribution of genes in the development of a disease :**
 - (a) Transgenic models help for the investigation of new treatments for human diseases.
 - (b) For example: transgenic models for many human diseases such as Cancer, Cystic Fibrosis, Rheumatoid arthritis and Alzheimer's disease.
- **Biological products :**
 - (a) Some medicines contain biological products, but they are often expensive.
 - (b) Transgenic animals are used to produce useful biological products by introducing genes that codes for a particular product. e.g., human protein (α -1-antitrypsin) used to treat emphysema, products for the treatment of Phenylketonuria (PKU) and Cystic fibrosis, etc.
 - (c) In 1997, *Rosie* (first transgenic cow) produced human protein-enriched milk (2.4 gm per litre).
 - (d) It contains the human alpha-lactalbumin and is nutritionally more balanced product for human babies than natural cow-milk.
- **Vaccine safety testing :** Transgenic mice are being developed and used in testing the safety of **vaccines** before they are used for humans. The polio vaccine was tested in mice.
- **Chemical safety testing (toxicity testing) :** Transgenic animals are made to know the effect of **toxic** chemicals. This is also known as toxicity / safety testing.



Key Fact

Mice have been genetically modified to naturally produce human antibodies for use as therapeutics. Seven out of the eleven monoclonal antibody drugs approved by the FDA between 2006 and 2011 were derived from transgenic mice.

➤ Ethical Issues

- **Problem of unpredictable results**
 - (a) Genetic modification may cause unpredictable results when such organisms are introduced into the ecosystem.
 - (b) Therefore, Indian Government has set up organizations like **GEAC** (Genetic Engineering Approval Committee), which makes decisions about the validity of GM research and the safety of GM-organisms for public services.
- **Problems of patent**
 - (a) Certain companies have got patents for products and technologies that make use of the genetic materials, plants etc. that have been identified, developed and used by farmers and indigenous people of a specific country.
 - (b) E.g., Basmati rice, herbal medicines like turmeric, neem, etc.
 - (c) Basmati rice has unique aroma and flavour.
 - (d) India has 27 varieties of Basmati.
 - (e) In 1997, an American company got patent rights on Basmati rice through the US Patent and Trademark Office.
 - (f) This allowed the company to sell a 'new' variety of Basmati which had actually been derived from Indian farmer's varieties.
 - (g) Indian Basmati was crossed with semi-dwarf varieties and claimed as a novelty.
 - (h) Other people selling Basmati rice could be restricted by the patent.
- **Biopiracy :**
 - (a) It is the use of bio-resources by multinational companies and other organizations without proper authorization from the countries and people concerned.
 - (b) Most of the industrialized nations are poor in biodiversity and traditional knowledge.
 - (c) The developing and the underdeveloped world have rich biodiversity and traditional knowledge related to bio-resources.
 - (d) It has to develop laws to prevent unauthorized exploitation of **bio-resources** and traditional knowledge.
 - (e) Indian Parliament has cleared the second amendment of the Indian Patents Bill that takes such issues into consideration, including **patent** terms, emergency provisions and research and development initiative.



Key Words

Vaccines : It is a liquid, containing a dead or attenuated pathogen or it is antigen that provides temporary or permanent immunity to disease.

Toxic : Substance which is harmful to living organisms or cells.

Biopatent : A patent is a right granted by a government to an inventor to prevent others from commercially using his invention. When patents are granted for biological entities and for products derived from them, these patents are called biopatents.

Bio-resources : These are natural renewable sources, Bio-resources are laboratory animals, plants, cells, genes, and microorganisms, used for researches.

Example 2

Q. What do you understand by Ethical issues?

Sol. Ethical issues occur when a given decision, scenario or activity creates a conflict with a society's moral principles. Both individuals and businesses can be involved in these conflicts, since any of their activities might be put to question from an ethical standpoint. For e.g., 27 varieties of Basmati are cultivated in India. This variety is known for its unique flavour and long grains. An American company cross-bred their semi-dwarf varieties with the Indian Basmati and claimed it to be a 'new' variety. The company even got the patent rights for the new variety without giving any compensation to the respective country or the farmers. This is known as biopiracy. This would severely affect the biodiversity of the concerned areas and harm the indigenous livelihoods. This is an ethical issue related to Genetically Modified Organisms.

UNIT – X: ECOLOGY AND ENVIRONMENT

CHAPTER-11

ORGANISMS AND POPULATIONS



Revision Notes

Characteristics of a Population

- **Population** : A population is defined as a group of individuals of the same species that live in a particular geographical area at a particular time and functioning as a unit.
- A population has certain attributes that an individual organism does not have. For example, individuals may have births and deaths, but a population has **birth rates** and **death rates**.
- **The birth and death rates** are referred to as per capita births or deaths respectively, which increases and decreases with respect to members of the population.
- **Sex ratio** is another attribute of the population. An individual may be male or female but the population has a **sex ratio**.
- A population at a given time is composed of different individuals of different ages. If the age distribution is plotted for the population, the resulting structure is called age pyramids. The shape of pyramids reflects the shape of the growth status of a population.
- **Population size or population density** (N) is measured in terms of number.
- **Population Growth** : The size of the population is not static. It keeps changing with time, depending upon food availability, predation, and adverse weather condition. The main factors that determine population growth are :
 - (i) Natality (number of births) [B]
 - (ii) Mortality (number of deaths) [D]
 - (iii) Immigration (individuals that come into habitat) [I]
 - (iv) Emigration (individual that leaves the habitat) [E]

If 'N' is population density at time 't', then its density at t + 1 is

$$N_{(t+1)} = N_t + [(B + I) - (D + E)]$$

Key Words

Birth rate (Natality) : It is the ratio of live births in an area to the population of an area.

Death rate (Mortality) : It is the ratio of deaths in an area to the population of an area.

Sex ratio : It is the number of males or females per thousand individuals.

Population density : It is defined as the number of individuals of a population present per unit area at a given time.

Differences between Natality Rate and Mortality Rate :

S. No.	Natality Rate	Mortality Rate
1.	Addition of new individuals due to birth, hatching, germination or division.	Number of individuals in a population decreases with the death of the individuals.
2.	Natality shows the number of offsprings produced per unit time per unit population.	Population density and its size is decreased by death rate.

► **Growth model** : Growth of population takes place according to the availability of food, habitat condition and presence of other biotic and abiotic factors. There are two main types of models :

- (i) **Exponential Growth** : This kind of growth occurs when food and space are available in a sufficient amount. The population grows exponentially or geometrically. If the size of a population is N , the birth rate is represented as ' b ' and death rate as ' d ', then increase and decrease in N during a unit period time ' t ' will be

$$dN/dt = (b - d) \times N$$

Let, $(b - d) = r.$

Then, $dN/dt = rN$

The r in this equation is called 'intrinsic rate of natural increase.'



Key Fact

Polar bear one of the world's largest living animals is Earth's number one apex predator. Apex predators are the top predators in the food chain.

- (ii) **Logistic Growth** : There is a competition between the individuals of a population for food and space. The 'fittest' organism survives and reproduces. This type of growth initially shows a lag phase followed by phases of acceleration and de-acceleration. K indicates the carrying capacity of the population.

$$dN/dt = rN \left(\frac{K - N}{K} \right)$$

Where, N = Population density at time t

r = Intrinsic rate of natural increase

k = Carrying capacity

► **Population interaction** : All animals, plants and microbes in a biological community interact with each other. These interactions may be beneficial, detrimental or neutral to one species or both.

The following types of interactions are seen :

- (a) **Predation** : It is the interaction between two species members in which the members of one species capture, kill and eat up the members of other species.
 (b) **Parasitism** : It is the relationship between two living organisms of different species in which one organism called a parasite obtains its food directly from another living organism called the host.
 (c) **Proto-cooperation** : It is the interaction between two living organisms of different species in which both are mutually benefitted but they can live without each other.
 (d) **Competition** : It is the rivalry between two or more organisms for obtaining the same resources.
 (e) **Mutualism** : It is the interaction between two organisms of different species where both the partners are benefitted but cannot live separately.

IMPORTANT DIAGRAMS :

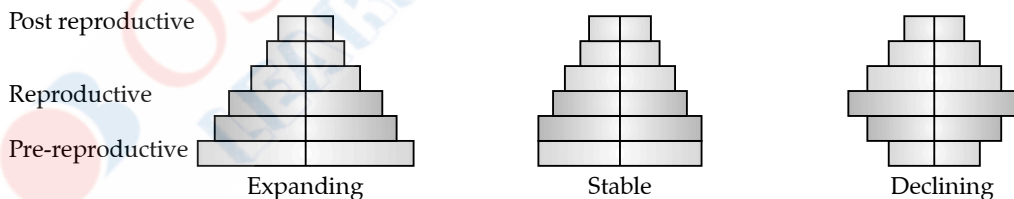

Fig. 11.1 Representation of age pyramids for human population

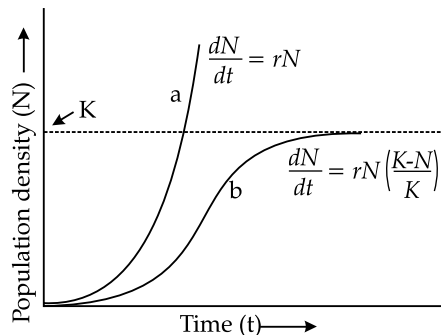

Fig. 11.2 Population Growth Curve :

- (a) When responses are not limiting the growth, plot is exponential.
 (b) When responses are limiting the growth, plot is logistic. It produces sigmoid curve (S-shaped).
 K is carrying capacity.



Mnemonics

Concept: Population Density at time $t + 1$

Interpretation: $N_{t+1} = N_t + [(B + I) - (D + E)]$

Mnemonic: Never try Before I Dare to Exit

Example

- Q. (i) List the different attributes that a population has and not an individual organism.
 (ii) What is population density? Explain any three different ways the population density can be measured, with the help of an example each.

Sol. (i) Following are the attributes that a population has but an individual organism does not have :

- (a) Birth rate : Per capita births.
 (b) Death rate : Per capita deaths.
 (c) Sex ratio : Ratio of number of males to females in a population.

(ii) **Population density** : It means number of

individuals present per unit area. Population density can be measured by determining the population size. The different methods to study population size are as follows :

- (a) **Quadrat method** : It is a method that involves the use of square of particular dimensions to measure the number of organisms e.g., The number of *Parthenium* plants in a given area can be measured using the quadrat method.
 (b) **Direct observation** : It involves the counting of organisms in a given area e.g., In order to determine the number of bacteria growing in a petridish, their colonies are counted.

CHAPTER-12

ECOSYSTEM

Topic-1

Patterns, Components, Productivity and Decomposition

Concepts Covered • *Ecosystem, Types of ecosystem, component of ecosystem, productivity and decomposition.*



Revision Notes

- **Introduction**
 - An ecosystem is a functional unit of nature, where living organisms interact among themselves and also with the surrounding physical environment.
 - The entire biosphere can be regarded as a global ecosystem.
- **Types of Ecosystems**
 - (a) **Terrestrial ecosystem** : Forest, grassland, desert, etc.
 - (b) **Aquatic ecosystem** : Pond, lake, wetland, river, estuary and ocean.
 - (c) **Man-made ecosystem** : Crop fields and aquarium.
- **Ecosystem : Structure and Function**
 - An ecosystem, consists of biotic and abiotic components. These components function as a unit. Unidirectional flow of energy takes place within these components of an ecosystem.
 - Vertical distribution of different species occupying different levels is called stratification. e.g., trees occupy top vertical strata (layer) of a forest, shrubs the second and herbs and grasses occupy the bottom layers.
- **Components of Ecosystem**

There are four main functions of ecosystem :

 - (i) Productivity (ii) Decomposition
 - (iii) Energy flow (iv) Nutrient cycling
 - **Example : Pond - Aquatic Ecosystem**
 - (a) A pond is a shallow, simple, self-sustainable water body that exhibits all basic components of an ecosystem.

- (b) **Abiotic components in pond** : Water and the soil which is deposited at the bottom.
- (c) **Climatic conditions** : The solar input, the cycle of temperature, day-length, etc.
- (d) **Autotrophic components** : **Phytoplankton**, some algae and the floating, submerged and marginal plants.



Key Words

Phytoplankton : They are microscopic marine algae.

Zooplanktons: Zooplankton is made up of small water invertebrates feeding on phytoplankton.

- (e) **Consumers (heterotrophs)** : **Zooplankton**, free swimming and bottom-dwelling forms.
- (f) **Decomposers** : Fungi, bacteria and flagellates.
- (g) **Pond performs all the functions of an ecosystem such as** :
 - (i) Conversion of inorganic into organic material with the help of the radiant energy of the sun by the autotrophs.
 - (ii) Consumption of the autotrophs by heterotrophs.
 - (iii) Decomposition and mineralization of the dead matter to release them back for reuse by the autotrophs.
- (h) There is a unidirectional movement of energy towards the higher trophic levels and its dissipation and loss as heat to the environment.

► Productivity

- (a) A constant input of solar energy is the basic requirement for any ecosystem to function and sustain.
- (b) The rate of biomass production is called productivity.
- (c) The productivity is expressed in terms of $g^{-2}yr^{-1}$ or $(kcal\ m^{-2})\ yr^{-1}$.
- (d) It can be divided into gross primary productivity (GPP) and net primary productivity (NPP).

► Primary Productivity

- (a) The amount of biomass or organic matter produced per unit area over a time period by plants during photosynthesis is called primary production.
- (b) The primary production is expressed in terms of weight (g^{-2}) or energy ($kcal\ m^{-2}$).

► Gross Primary Productivity

- (a) It is the rate of production of organic matter during photosynthesis.
- (b) A considerable amount of GPP is utilized by plants in respiration.
- (c) Gross primary productivity minus respiration losses (R) is the net primary productivity (NPP), i.e., NPP is the available biomass for the consumption of heterotrophs (herbivores and decomposers).

$$NPP = GPP - R$$

(d) Primary productivity depends on

- (i) The plant species inhabiting a particular area.



Key Facts

- Phytoplankton are responsible for producing upto 50% of the oxygen we breathe.
- Zooplanktons eat algae, so they can be used to control algal blooms. This method is called "biomagnification".

- (ii) Environmental factors.
- (iii) Availability of nutrients.
- (iv) Photosynthetic capacity of plants.
Therefore, it varies in different types of ecosystems.
- (e) The annual net primary productivity of the whole biosphere is approximately 170 billion tons (dry weight) of organic matter.
- (f) Of this, despite occupying about 70% of the surface, the productivity of the oceans is only 55 billion tons. The rest of course is on land.

► Secondary Productivity

It is the rate of formation of new organic matter by consumers.

► Decomposition

- (a) It is the breakdown of complex organic matter by decomposers into inorganic substances like carbon dioxide, water and nutrients.
- (b) It is largely an oxygen-requiring process.
- (c) **Detritus** (dead plant remains such as leaves, bark, flowers and dead remains of animals, including faecal matter) is the raw material for decomposition.

► Steps in decomposition

The important steps in the process of decomposition are fragmentation, leaching, catabolism, humification and mineralisation.

- (a) **Fragmentation**

It is the breakdown of detritus into smaller particles by **detritivores** (e.g., Earthworm).

(b) **Leaching**

In this process, water-soluble inorganic nutrients go down into the soil horizon and get precipitated as unavailable salts.

(c) **Catabolism**

(i) Here, the degradation of detritus into simpler inorganic substances takes place by bacterial and fungal enzymes.

(ii) Fragmentation, leaching and catabolism operate simultaneously on the detritus.



Key Word

Detritivores : Animals that feed on decaying organic matter (detritus). Examples: earthworms, termites, snails, etc.

(d) **Humification**

(i) It is the accumulation of humus (dark amorphous substance) in soil.

(ii) Humus is resistant to microbial action and so decomposes very slowly.

(iii) Being colloidal, it serves as a reservoir of nutrients.

(e) **Mineralization**

It is the release of inorganic nutrients due to the degradation of humus by some microbes.

► **Factors Influencing Decomposition**

The rate of decomposition is controlled by the chemical composition of detritus and climatic factors.

(a) **Chemical composition of detritus :**

Decomposition rate is slower if detritus is rich in lignin and chitin and quicker, if detritus is rich in nitrogen and water-soluble substances like sugars.

(b) **Climatic factors like temperature and soil moisture :**

– Temperature and soil moisture are the most important climatic factors that regulate decomposition through their effects on the activities of soil microbes.

– Warm and moist environment favours decomposition whereas low temperature and anaerobic conditions inhibits decomposition resulting in the build up of organic materials.



Mnemonics

Concept : Steps in decomposition

Mnemonics : Fly Like Crane with High Moral

Interpretations : Fragmentation, Leaching, Catabolism, Humification, Mineralization

Example 1

Q. How are productivity, gross productivity, net primary productivity and secondary productivity interrelated ?

Sol. $NPP = GPP - R$

NPP- Net Primary Productivity

GPP- Gross Primary Productivity

R - Respiration

Productivity is the rate of production of biomass at any trophic level at any given interval of time.

Gross productivity : It is the rate of production of

organic matter by green plants per unit time per unit area. On the other hand we can say that it is the total amount of productivity.

Net Primary Productivity : It is the difference between gross primary productivity and the loss due to respiration.

Secondary Productivity : It is rate of production or formation of new organic matter by consumers especially the consumers of the first order or herbivores.

Topic-2

Energy Flow and Ecological Pyramids

Concepts Covered • Energy flow in an ecosystem, Ecological pyramids- Pyramid of number, Pyramid of biomass and Pyramid of energy.



Revision Notes

► **Energy Flow**

- Sun is the only source of energy for all ecosystems on the earth.
- Of the incident solar radiation less than 50% of it is photosynthetically active radiation (PAR).
- Plants, photosynthetic and chemosynthetic bacteria (autotrophs) fix solar radiant energy to make food.

- Plants capture only 2-10% of the PAR and this small amount of energy sustains the entire living world. So, it is very important to know how the solar energy captured by plants flows through different organisms of an ecosystem.
- Ecosystem obeys first and second law of Thermodynamics.
- The energy of the ecosystem is constant.
- They need a constant supply of energy to synthesize the molecules they require, to counteract the universal tendency toward increasing disorderliness.

► Producers

- The green plants in the ecosystem which capture the solar energy and convert it into chemically bound energy are called producers.
- All organisms are dependent for their food on producers (green plants), either directly or indirectly.
- In a terrestrial ecosystem, major producers are herbaceous and woody plants.
- Primary producers in an aquatic ecosystem are phytoplankton, algae and higher plants.
- The energy trapped by the producer is either passed on to a consumer or the organism dies.
- Death of an organism is the beginning of the detritus food chain / web.



Key Fact

The energy that enters the ecosystem, is measured in Joules or Calories. Thus, the energy flow is also called calorific flow.

► Consumers (Heterotrophs)

- These are all animals that depend on plants (directly or indirectly) for their food.
- **They include :**
 - Primary Consumers**
 - These are herbivores that feed on plants.
 - For e.g., Insects, birds and mammals in the terrestrial ecosystem and molluscs in aquatic ecosystem.
 - Secondary Consumers**
 - These are primary carnivores that feed on herbivores e.g., Frog, fox, man etc.
 - Tertiary Consumers**
 - These are secondary carnivores that feed on primary carnivores.



Key Words

Trophic Level : A specific place of organisms in the food chain is known as their trophic level.

Ecological Pyramids: The representation of a food chain in the form of a pyramid is called ecological pyramids.

► Grazing Food Chain

- A simple grazing food chain (GFC) is depicted below :

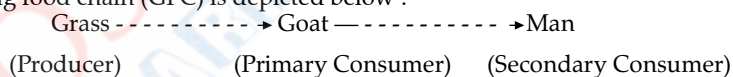

► Detritus Food Chain (DFC)

- It begins with dead organic matter.
- It is made up of decomposers (saprotrophs) which are heterotrophic organisms. e.g. fungi and bacteria.
- They meet their energy and nutrient requirements by degrading dead organic matter or detritus.
- Decomposers secrete digestive enzymes that breakdown dead and waste materials into simple, inorganic materials, which are subsequently absorbed by them.
- In an aquatic ecosystem, GFC is the major conduit for energy flow.
- In a terrestrial ecosystem, a much larger fraction of energy flows through the DFC than through the GFC.
- DFC may be connected with GFC at some levels : some of the organisms of DFC are prey to the GFC animals.
- Some animals (cockroaches, crows etc.) are omnivores.
- These interconnections of food chains make a food web.
- Organisms occupy a place in the natural surroundings or in a community according to their feeding relationship.
- A specific place of organisms in the food chain is known as their trophic level.
- Producers belong to the first trophic level, herbivores to the second and carnivores to the third.
- The amount of energy decreases at successive **trophic levels**.
- When an organism dies it becomes dead biomass (detritus) that serves as an energy source for decomposers.
- Organisms at each trophic level depend on those at the lower trophic level for their energy demands.
- Each trophic level has a certain mass of living material at a particular time called as the standing crop.
- The standing crop is measured as the mass of living organisms (biomass) or the number in a unit area. Biomass of a species is expressed in terms of fresh or dry weight.
- Measurement of biomass in terms of dry weight is more accurate.

- The number of trophic levels in the grazing food chain is restricted as the transfer of energy follows **Lindemann's 10 % law**, which states that only 10% of the energy is transferred to each trophic level from the lower trophic level.
- In nature, it is possible to have so many levels – producer, herbivore, primary carnivore, secondary carnivore in the grazing food chain.

► **Ecological Pyramids**

- The representation of a food chain in the form of a pyramid is called an ecological pyramid. It is the relationship between the producers and consumers of various order represented graphically.
- The base of each pyramid represents the producers (first trophic level) while the apex represents tertiary or top level consumer or the last trophic level.
- **Ecological pyramids are of three types :**
 - (a) Pyramid of number
 - (b) Pyramid of biomass
 - (c) Pyramid of energy
- Any calculations of energy content, biomass or numbers have to include all organisms at that **trophic level**.
- The trophic level represents a functional level, not a species as such.
- A given species may occupy more than one trophic level in the same ecosystem at the same time. For e.g., A sparrow is a primary consumer when it eats seeds, fruits, peas, and a secondary consumer when it eats insects and worms.
- In most ecosystems, all the pyramids are upright i.e. producers are more in number and biomass than the herbivores and herbivores are more in number and biomass than the carnivores.
- Also, energy at a lower trophic level is always more than at a higher level.
- Example of inverted pyramids includes insects feeding on a big tree.
- Pyramid of biomass in the sea is generally inverted because the biomass of fishes far exceeds that of phytoplankton.
- Pyramid of energy is always upright, because when energy flows from a trophic level to the next trophic level, as some energy is always lost as heat at each step.

► **Limitations of Ecological Pyramids**

- (a) It does not take into account the same species belonging to two or more trophic levels.
- (b) It assumes a simple food chain that seldom exists in nature. It does not accommodate a food web.
- (c) Saprophytes are not included in ecological pyramids even though they play a vital role in the ecosystem.

IMPORTANT DIAGRAMS

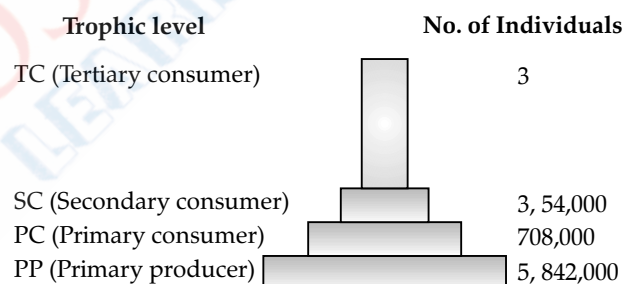

Fig. 12.1 Pyramid of numbers in a grassland ecosystem

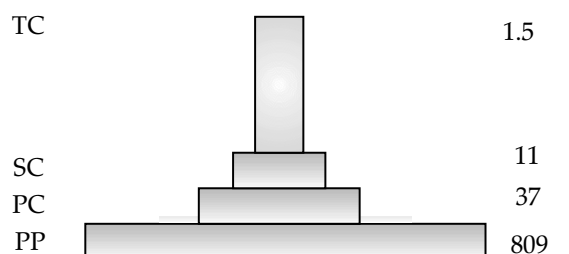

Fig. 12.2 Pyramid of Biomass in most Ecosystem

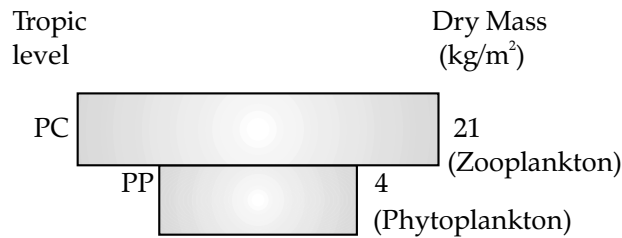

Fig. 12.3 Inverted Pyramid of Biomass in Sea

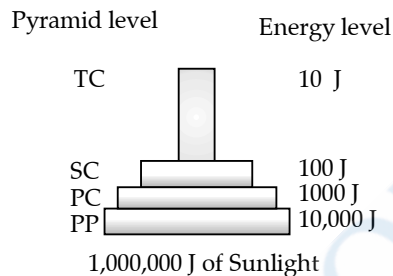

Fig. 12.4 An ideal pyramid of energy



Mnemonics

Concept: Types of Ecological pyramids

Mnemonic: Put No Entry Board

Interpretation:

- (i) Pyramid of number
- (ii) Pyramid of energy
- (iii) Pyramid of biomass

Example 2

Q. Write the outcomes of the following events.

- (a) The consequence of eliminating all producers.
- (b) The consequence of eliminating all entities at the herbivore level.
- (c) The consequence of eliminating all top carnivore entities.

Sol. (a) It diminishes primary production in an ecosystem and hence unavailability of biomass to higher trophic levels.

(b) It would result in an increase in primary productivity and biomass of producers. Carnivorous animals, due to unavailability of food, will not survive.

(c) There will be an increase in the herbivore population, resulting in over-grazing and hence desertification.

CHAPTER-13

BIODIVERSITY AND ITS CONSERVATION

Topic-1

Biodiversity and its Patterns

Concepts Covered • Biodiversity, different levels of biodiversity, importance of biodiversity, causes of biodiversity loss.



Revision Notes

- **Biodiversity** : It is the diversity (or heterogeneity) of biological organisation ranging from cellular macromolecules to biomes.
- **Edward Wilson** : Popularized the term 'biodiversity' to describe the combined diversity at all levels of biological organization.

► Levels of Biodiversity

- Biodiversity has been divided into three hierarchical levels of biological organization.

1. Genetic diversity

- (a) Diversity shown by a single species at the genetic level. e.g., *Rauwolfia vomitoria* in Himalaya shows genetic variation in the potency and concentration of the chemical, reserpine.
- (b) India has more than 50,000 different strains of rice and 1,000 varieties of mango.

2. Species diversity

Diversity at the species level. e.g., Western Ghats have greater amphibian species than the Eastern Ghats.

3. Ecological diversity

Diversity at ecosystem level. For e.g., In India, deserts, rain forests, mangroves, coral reefs, wetlands, estuaries & alpine meadows, all can be seen, whereas the Scandinavian countries (like, Norway, Sweden) have less ecological diversity.

► Number of Species on Earth (Global Species Diversity)

- According to IUCN or International Union for Conservation of Nature & Natural Resources (2004) more than 1.5 million species have been described so far.
- According to Robert May, the global estimate is about 7 million (considering the species are to be discovered in the tropics. i.e., only 22% of the total species have been recorded so far).
- Animals are more diverse (above 70%) than Plants including plantae and fungi (22%).
- Most species-rich taxonomic group among animals are : Insects (70%, i.e., out of every 10 animals, 7 are insects).
- Number of fungal species is more than the combined total of the species of fishes, amphibians, reptiles and mammals.
- Biologists are not sure about total number of prokaryotic species because :
 - (a) Conventional taxonomic methods are not suitable for identifying microbial species.
 - (b) Many species are not culturable under laboratory conditions.
- India has only 2.4% of the world's land area, but has 8.1% of the species diversity.
- India is one of the 12 mega diversity countries of the world.
- Nearly 45,000 species of plants and twice as many of animals have been recorded from India.
- Applying May's global estimate, India would have more than 1 lakh plant species and 3 lakh animal species.

► Patterns of Biodiversity

- Biodiversity is not uniform throughout the world. It varies with the change in latitude and altitude, it is affected by latitudinal gradients and species-area relationship. Following are the main patterns of biodiversity.

(a) Latitudinal Gradients

- Species diversity decreases from the equator to the poles.
- Tropics (latitudinal range of 23.5° N to 23.5° S) have more species than temperate or polar areas.
 - (i) Colombia (near equator) has about 1400 species of birds.
 - (ii) New York (41° N) : 105 species of birds
 - (iii) Greenland (71° N) : 56 species of birds
 - (iv) India (tropical latitudes) : > 1200 species
- Tropical forest region like Ecuador has up to 10 times species of vascular plants as compared to a forest of equal area in a temperate region like the Midwest of USA.



Key Facts

- The current observed extinction rate is 2.6 vertebrate species per 10,000 yearly.
- About one million plant and animal species are facing the threat of extinction.

- Tropical Amazonian rain forest (South America) has the greatest biodiversity on earth. It contains :
 - (i) 40,000 species of plants
 - (ii) 3,000 species of fish
 - (iii) 1,300 species of birds
 - (iv) 427 species of mammals
 - (v) 427 species of amphibians
 - (vi) 378 species of reptiles
 - (vii) 1,25,000 species of invertebrates
- Biodiversity (species richness) is highest in tropics because
 - (i) Tropics had more evolutionary time.
 - (ii) Relatively constant environment (less seasonal).
 - (iii) They receive more solar energy which contributes to greater productivity.
- (b) Species - Area Relationship
 - According to the study of Alexander von Humboldt (German naturalist & geographer) in South American jungles, within a region, species richness increases with an increase in explored area, but only up to a limit.

- Relation between species richness and area for a wide variety of taxa (like, angiospermic plants, birds, freshwater fishes) gives a rectangular hyperbola.
- On a logarithmic scale, the relationship is a straight line or linear, described by the equation :

$$\log S = \log C + Z \log A$$
 where, S = Species richness, A = Area, C = Y-intercept, Z = slope of the line (regression co-efficient)
- The value of Z lies in the range of 0.1 to 0.2.
- In the species-area relationship among the large areas like entire continents, the slope of the line is steeper (Z value : 0.6 to 1.2). e.g., for frugivorous birds and mammals in the tropical forests of different continents, the slope is 1.15.

► Importance of Species Diversity to the Ecosystem

- For many decades, ecologists believed that communities with more species, generally, tend to be more stable than those with fewer species.
- A stable community should not show too much variation in productivity from year to year; it must be either resistant or resilient to occasional disturbances (natural or man-made), and it must also be resistant to invasions by alien species.
- **David Tilman** found that plots with more species showed less year-to-year variation in total biomass.
- He also showed that in his experiments, increased diversity contributed to higher productivity.
- A rich biodiversity is not only essential for ecosystem health but imperative for the survival of the human race on this planet.
- Stanford ecologist **Paul Ehrlich** explained the effect of loss of species through his 'rivet popper hypothesis'.

► Loss of Biodiversity

- IUCN Red List (2004) says that 784 species (338 vertebrates, 359 invertebrates and 87 plants) became **extinct** in the last 500 years. e.g., Dodo (Mauritius), Quagga (Africa), Thylacine (Australia), Stellar's sea cow (Russia) and 3 subspecies (Bali, Javan, Caspian) of the tiger.
- 27 species have disappeared in the last 20 years.
- The extinctions across taxa are not random. Some groups (like amphibians) appear to be more vulnerable to extinction.



Key Words

Biodiversity : It includes all different life forms in one given area, from humans to organism like microbes, fungi and invertebrates.

Extinct : The species which no more exist on the Earth.

- More than 15,500 species are facing the threat of extinction.
- 12% birds, 23% mammals, 32% amphibians, 31% gymnosperm species face the threat of extinction.
- On earth, there have been five mass extinctions of species and at present 'Sixth Extinction' is in progress.
- The current extinction rate is 100 - 1000 times faster than in pre-human times. If this trend continues, nearly 50% species might be extinct within the next 100 years.

► Impacts of Loss of Biodiversity

- (a) Decline in plant production.
- (b) Lowered resistance to some environmental perturbations such as drought.
- (c) Increased variability in ecosystem processes such as plant productivity, water use and pest and disease cycles.



Key Words

Alien species : A species which is introduced outside its natural part or present distribution. It includes any part such as gametes, seeds, eggs, etc., which might survive and subsequently reproduce.

Aquaculture : It is a controlled cultivation of aquatic organisms such as fish, algae, etc.

► Causes of Biodiversity Losses ('The Evil Quartet')

- "The Evil Quartet" is the phrase coined by Jared Diamond to describe the four human induced causes of extinction.
- (a) **Habitat Loss and Fragmentation**
 - It is the most important cause. For e.g., Tropical rain forests (loss from 14% to 6%).
 - Thousands of hectares of rain forests are being lost within hours.
 - The Amazon rain forest ('lungs of the planet') is being cut for cultivating soya beans or for the conversion of grasslands for cattle.

- When large habitats are broken up into small fragments due to various human activities, mammals and birds requiring large territories and certain animals with migratory habits are badly affected, leading to population decline.

(b) Over-exploitation

- The dependence of humans on nature for food and shelter led to the over-exploitation of natural resources.
- **Example :** Many species like Stellar's sea cow, Passenger pigeon, etc, became extinct due to over-exploitation.
- Many marine fish populations around the world are over-harvested, endangering the continued existence of some commercially important species.

(c) Alien Species Invasions

- When **alien species** are introduced unintentionally or deliberately, some of them turn invasive, and cause the decline or extinction of indigenous species.
- These alien species cause decline or extinction of indigenous species.
- Example : **(a)** The Nile Perch introduced in Lake Victoria (East Africa) caused extinction of more than 200 species of cichlid fish.
 - (b)** Invasive weed species like carrot grass (*Parthenium*), *Lantana* and water hyacinth (*Eichhornia*) caused damage to our native species.
 - (c)** The illegal introduction of the African Catfish (*Clarias gariepinus*) for **aquaculture** is posing a threat to the indigenous catfish (*Clarias batrachus*) in our rivers.

(d) Co-extinction

- When a species becomes extinct, the plant and animal species associated with it also become extinct.
- **Example :**
 - (a)** Extinction of the parasites takes place when the host is extinct.
 - (b)** In co-evolved plant-pollinator mutualism extinction of one leads to the extinction of the other.



Mnemonics

Concept: Components of Biodiversity

Mnemonic: Grand School Exhibition

Interpretation: Genetic diversity, Species diversity, Ecological diversity

Example

- Q.** Mention the kind of biodiversity of more than a thousand varieties of mangoes in India represent. How is it possible.
- Sol.** More than a thousand varieties of mangoes in India represent the genetic diversity. It is because :
- (i) a single species show high diversity at genetic level over its distributional range.
 - (ii) different varieties grow in different geographical regions and climatic condition. This is also possible because of breeding and mutations.

Topic-2

Conservation of Biodiversity

Concepts Covered • Conservation processes, Types of Conservation



Revision Notes

Conservation Processes

- There are three main reasons for conserving the biodiversity which are categorized as follows :

(a) Narrowly Utilitarian Arguments

- Humans derive economic benefits from nature such as food, firewood, fibre, construction material, industrial products (tannins, lubricants, dyes, resins, perfumes) and medicines.
- More than 25% of the drugs are derived from plants.
- 25,000 species of plants have medicinal value.

- Exploring molecular, genetic and species-level diversity for i.e., 'bioprospecting' products of economic importance may enormously benefit nations with rich biodiversity.

(b) Broadly Utilitarian Arguments

- Biodiversity has many ecosystem services.
- Amazon forest produces 20% of total O₂ in the earth's atmosphere by the process of photosynthesis.
- Pollination service takes place through bees, bumblebees, birds and bats.
- Aesthetic pleasures such as walking through thick woods, watching spring flowers in full bloom or waking by hearing a bulbul's song in the morning.
- Other indirect benefits are pest control, climate moderation and flood control.

(c) Ethical Arguments

- Every species has an intrinsic value.
- We have a moral duty to take care for their well-being.



Key Facts

- Species density is greater in the Southern Hemisphere.
- The entire Hindu- Kush Himalayan belt has around 25,000 plant species, comprising 10 per cent of the world's flora.

► Conservation of Biodiversity

Types of Conservation

(a) *In situ* conservation (on site)

- It is the conservation of genetic resources within natural or human-made ecosystems in which they occur.
- Examples: Protected areas such as National Parks, Sanctuaries, Biosphere reserves, cultural landscapes, national monuments.

(i) National Park

- Strictly reserved for the welfare of the wildlife where private ownership, cultivation, grazing, etc., are prohibited.
- There are 90 national parks in India.

(ii) Sanctuary

- Here, protection is given only to the animals.
- Collection of timbers, minor forest products and private ownership are allowed so long as they do not harm the animals.
- There are 553 wildlife sanctuaries in India.

(iii) Biosphere Reserves

- Areas of land or coastal environments to conserve the ecosystem and genetic resources contained therein.
- There are 18 biosphere reserves in India.

(iv) Sacred Forests (Sacred Groves)

- Sacred groves are highly protected forests because of religious and cultural traditions.
- Sacred groves in Khasi and Jaintia Hills in Meghalaya.
- Aravalli Hills of Rajasthan.
- Western Ghat regions of Karnataka & Maharashtra.
- Sarguja, Chanda and Bastar areas of Madhya Pradesh.
- In Meghalaya, the sacred groves are the last refuges for a large number of rare and threatened plants.

(v) Hotspots

- These are the richest and the most threatened reservoirs of plant and animal life on earth.
- There are 36 hotspots in the world.
- In total, all the biodiversity hotspots cover less than 2% of the earth's land area but could reduce the ongoing extinctions by almost 30%.
- Three main hotspots (Western Ghats and Sri Lanka, Indo-Burma and Himalaya) cover India's biodiversity regions.

(b) *Ex situ* conservation (off site)

- It is the conservation of organisms outside their habitats.
- In this approach, threatened animals and plants are taken out from their natural habitat and placed in a special setting where they can be protected and given special care. For e.g., genetic resource centres, zoological parks, botanical gardens, gene banks etc.

- In recent years, *ex-situ* conservation has advanced by preserving the gametes of threatened species in viable and fertile condition for long periods using **cryopreservation** techniques, eggs can be fertilised *in-vitro*, and plants can be propagated using **tissue culture** methods.
- Seeds of different genetic strains of commercially important plants can be kept for long periods in seed banks.



Key Words

Hot spots : It is a biogeographic region which serve as significant reservoir of biodiversity but they are threatened due to degradation, illegal logging, etc.

Cryopreservation : The process of preserving cells, tissues, organs at very low or freezing temperatures.

Tissue culture : Growing cells and tissues in an artificial medium.

Sustainable development: Development meets the needs of the present generation without compromising the ability of future generation.

► International Efforts for Conserving Biodiversity

- **The Earth Summit (Rio de Janeiro, 1992) - Three objectives :**
 - (a) Conservation of biodiversity
 - (b) Sustainable use of biodiversity
 - (c) Sharing of benefits in the utilization of genetic resources.
- The World Summit on **Sustainable Development** (Johannesburg, South Africa, 2002) : 190 countries pledged to reduce the current rate of biodiversity loss.



Mnemonics

Concept: Conservation of Biodiversity (*In-situ* conservation)

Mnemonic: National Service Best Service Hai

Interpretation: National park, Sanctuary, Biosphere reserve, Sacred forest, Hotspots

