

CBSE

Solved Paper 2023

Mathematics Standard

(Delhi & Outside Delhi Sets)

Time : 3 Hours

CLASS-X

Max. Marks : 80

General Instructions:

Read the following instructions carefully and follow them:

- (i) This question paper contains 38 questions. All questions are compulsory.
- (ii) Question paper is divided into FIVE sections - Section A, B, C, D and E.
- (iii) In section A, question number 1 to 18 are multiple choice questions (MCQs) and question number 19 and 20 are Assertion - Reason based questions of 1 mark each.
- (iv) In section B, question number 21 to 25 are very short answer (VSA) type questions of 2 marks each.
- (v) In section C, question number 26 to 31 are short answer (SA) type questions carrying 3 marks each.
- (vi) In section D, question number 32 to 35 are long answer (LA) type questions carrying 5 marks each.
- (vii) In section E, question number 36 to 38 are case based integrated units of assessment questions carrying 4 marks each. Internal choice is provided in 2 marks question in each case study.
- (viii) There is no overall choice. However, an internal choice has been provided in 2 questions in Section B, 2 questions in Section C, 2 questions in Section D and 3 questions in Section E.
- (ix) Draw neat figures wherever required. Take $\pi = 22/7$ wherever required if not stated.
- (x) Use of calculators is **not allowed**.

Delhi Set-I

30/4/1

SECTION — A

Section-A consists of Multiple Choice Type questions of 1 mark each

1. The ratio of HCF to LCM of the least composite number and the least prime number is:
(a) 1 : 2
(b) 2 : 1
(c) 1 : 1
(d) 1 : 3
2. The roots of the equation $x^2 + 3x - 10 = 0$ are:
(a) 2, -5
(b) -2, 5
(c) 2, 5
(d) -2, -5
3. The next term of the A.P.: $\sqrt{6}, \sqrt{24}, \sqrt{54}$ is:
(a) $\sqrt{60}$
(b) $\sqrt{96}$
(c) $\sqrt{72}$
(d) $\sqrt{216}$
4. The distance of the point (-1, 7) from x-axis is:
(a) -1
(b) 7
(c) 6
(d) $\sqrt{50}$
5. What is the area of a semi-circle of diameter 'd' ?
(a) $\frac{1}{16}\pi d^2$
(b) $\frac{1}{4}\pi d^2$
(c) $\frac{1}{8}\pi d^2$
(d) $\frac{1}{2}\pi d^2$

6. The empirical relation between the mode, median and mean of a distribution is:
- (a) Mode = 3 Median – 2 Mean (b) Mode = 3 Mean – 2 Median
(c) Mode = 2 Median – 3 Mean (d) Mode = 2 Mean – 3 Median
7. The pair of linear equations $2x = 5y + 6$ and $15y = 6x - 18$ represents two lines which are:
- (a) intersecting (b) parallel
(c) coincident (d) either intersecting or parallel
8. If α, β are zeroes of the polynomial $x^2 - 1$, then value of $(\alpha + \beta)$ is:
- (a) 2 (b) 1
(c) -1 (d) 0
9. If a pole 6 m high casts a shadow $2\sqrt{3}$ m long on the ground, then sun's elevation is:
- (a) 60° (b) 45°
(c) 30° (d) 90°
10. $\sec \theta$ when expressed in terms of $\cot \theta$, is equal to:
- (a) $\frac{1 + \cot^2 \theta}{\cot \theta}$ (b) $\sqrt{1 + \cot^2 \theta}$
(c) $\frac{\sqrt{1 + \cot^2 \theta}}{\cot \theta}$ (d) $\frac{\sqrt{1 - \cot^2 \theta}}{\cot \theta}$
11. Two dice are thrown together. The probability of getting the difference of numbers on their upper faces equals to 3 is:
- (a) $\frac{1}{9}$ (b) $\frac{2}{9}$
(c) $\frac{1}{6}$ (d) $\frac{1}{12}$

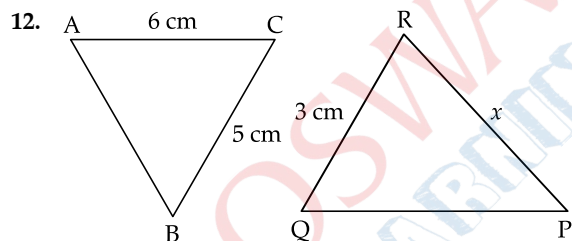

In the given figure, $\triangle ABC \sim \triangle QPR$. If $AC = 6$ cm, $BC = 5$ cm, $QR = 3$ cm and $PR = x$; then the value of x is:

- (a) 3.6 cm (b) 2.5 cm
(c) 10 cm (d) 3.2 cm
13. The distance of the point $(-6, 8)$ from origin is:
- (a) 6 (b) -6
(c) 8 (d) 10
14. In the given figure, PQ is a tangent to the circle with centre O . If $\angle OPQ = x$, $\angle POQ = y$, then $x + y$ is:

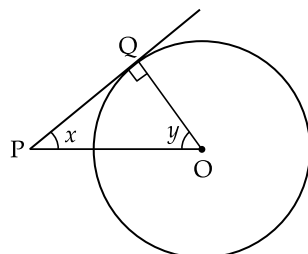

- (a) 45° (b) 90°
(c) 60° (d) 180°

15. In the given figure, TA is a tangent to the circle with centre O such that $OT = 4$ cm, $\angle OTA = 30^\circ$, then length of TA is:

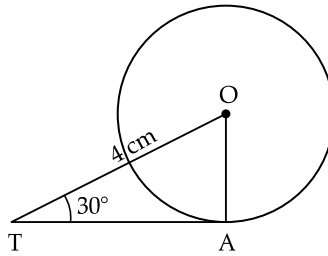

- (a) $2\sqrt{3}$ cm (b) 2 cm
(c) $2\sqrt{2}$ cm (d) $\sqrt{3}$ cm
16. In $\triangle ABC$, $PQ \parallel BC$. If $PB = 6$ cm, $AP = 4$ cm, $AQ = 8$ cm, find the length of AC.

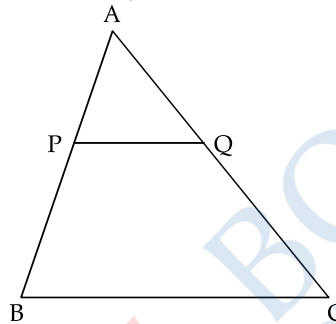

- (a) 12 cm (b) 20 cm
(c) 6 cm (d) 14 cm
17. If α, β are the zeroes of the polynomial $p(x) = 4x^2 - 3x - 7$, then $\left(\frac{1}{\alpha} + \frac{1}{\beta}\right)$ is equal to:

- (a) $\frac{7}{3}$ (b) $-\frac{7}{3}$
(c) $\frac{3}{7}$ (d) $-\frac{3}{7}$

18. A card is drawn at random from a well-shuffled pack of 52 cards. The probability that the card drawn is not an ace is:

- (a) $\frac{1}{13}$ (b) $\frac{9}{13}$
(c) $\frac{4}{13}$ (d) $\frac{12}{13}$

DIRECTIONS: In the question number 19 and 20, a statement of **Assertion (A)** is followed by a statement of **Reason (R)**. Choose the correct option out of the following:

19. **Assertion (A):** The probability that a leap year has 53 Sunday is $\frac{2}{7}$.

Reason (R): The probability that a non-leap year has 53 Sunday is $\frac{5}{7}$.

- (a) Both Assertion (A) and Reason (R) are true and Reason (R) is the correct explanation of Assertion (A).
(b) Both Assertion (A) and Reason (R) are true and Reason (R) is not the correct explanation of Assertion (A).
(c) Assertion (A) is true but Reason (R) is false.
(d) Assertion (A) is false but Reason (R) is true.
20. **Assertion (A):** a, b, c are in A.P. if and only if $2b = a + c$.
Reason (R): The sum of first n odd natural numbers is n^2 .
- (a) Both Assertion (A) and Reason (R) are true and Reason (R) is the correct explanation of Assertion (A).
(b) Both Assertion (A) and Reason (R) are true and Reason (R) is not the correct explanation of Assertion (A).
(c) Assertion (A) is true but Reason (R) is false.
(d) Assertion (A) is false but Reason (R) is true.

SECTION — B

Section - B consists of Very Short Answer (VSA) type questions of 2 marks each.

21. Two number are in the ratio 2 : 3 and their LCM is 180. What is the HCF of these numbers?
22. If one zero of the polynomial $p(x) = 6x^2 + 37x - (k - 2)$ is reciprocal of the other, then find the value of k .
23. (A) Find the sum and product of the roots of the quadratic equation $2x^2 - 9x + 4 = 0$.
- OR**
- (B) Find the discriminant of the quadratic equation $4x^2 - 5 = 0$ and hence comment on the nature of roots of the equation.
24. If a fair coin is tossed twice, find the probability of getting 'atmost one head'.
25. (A) Evaluate: $\frac{5\cos^2 60^\circ + 4\sec^2 30^\circ - \tan^2 45^\circ}{\sin^2 30^\circ + \cos^2 30^\circ}$
- OR**
- (B) If A and B are acute angles such that $\sin(A - B) = 0$ and $2\cos(A + B) - 1 = 0$, then find angles A and B.

SECTION — C

Section - C consists of Short Answer (SA) type questions of 3 marks each.

26. (A) How many terms are there in an A.P. whose first and fifth terms are -14 and 2, respectively and the last term is 62.
- OR**
- (B) Which term of the A.P.: 65, 61, 57, 53, is the first negative term?
27. Prove that $\sqrt{5}$ is an irrational number.
28. Prove that the angle between the two tangents drawn from an external to circle is supplementary to the angle subtended by the line joining the points of contact at the centre.
29. (A) Prove that: $\frac{\sin A - 2\sin^3 A}{2\cos^3 A - \cos A} = \tan A$
- OR**
- (B) Prove that $\sec A (1 - \sin A) (\sec A + \tan A) = 1$.
30. Two concentric circles are of radii 5 cm and 3 cm. Find the length of the chord of the larger circle which touches the smaller circle.
31. Find the value of 'p' for which the quadratic equation $px(x - 2) + 6 = 0$ has two equal real roots.

SECTION — D

Section - D consists of Long Answer (LA) type questions of 4 marks each.

32. (A) A straight highway leads to the foot of a tower. A man standing on the top of the 75 m high tower observes two cars at angles of depression of 30° and 60° , which are approaching the foot of the tower. If one car is exactly behind the other on the same side of the tower, find the distance between the two cars. (Use $\sqrt{3} = 1.73$)
- OR**
- (B) From the top of a 7 m high building, the angle of elevation of the top of a cable tower is 60° and the angle of depression of its foot is 30° . Determine the height of the tower.
33. (A) D is a point on the side BC of a triangle ABC such that $\angle ADC = \angle BAC$, prove that $CA^2 = CB \cdot CD$
- OR**
- (B) If AD and PM are medians of triangles ABC and PQR respectively where $\triangle ABC \sim \triangle PQR$, prove that $\frac{AB}{PQ} = \frac{AD}{PM}$.
34. A student was asked to make a model shaped like a cylinder with two cones attached to its ends by using a thin aluminium sheet. The diameter of the model is 3 cm and its total length is 12 cm. If each cone has a height of 2 cm, find the volume of air contained in the model.
35. The monthly expenditure on milk in 200 families of a Housing Society is given below:

Monthly Expenditure (in ₹)	1000 - 1500	1500 - 2000	2000 - 2500	2500 - 3000	3000 - 3500	3500 - 4000	4000 - 4500	4500 - 5000
Number of Families	24	40	33	x	30	22	16	7

Find the value of x and also, find the median and mean expenditure on milk.

SECTION — E

Section - E consists of three Case Study Based questions of 4 marks each.

36. Two schools 'P' and 'Q' decided to award prizes to their students for two games of Hockey ₹ x per student and Cricket ₹ y per student. School 'P' decided to award a total of ₹ 9,500 for the two games to 5 and 4 students respectively; while school 'Q' decided to award ₹ 7,370 for the two games to 4 and 3 students respectively.



Based on the above information, answer the following questions:

- (i) Represent the following information algebraically (in terms of x and y).
 - (ii) (a) What is the prize amount for hockey?
(b) Prize amount on which game is more and by how much?
 - (iii) What will be the total prize amount if there are 2 students each from two games ?
37. Jagdish has a field which is in the shape of a right angled triangle AQC. He wants to leave a space in the form of a square PQRS inside the field from growing wheat and the remaining for growing vegetables (as shown in the figure). In the field, there is a pole marked as O.

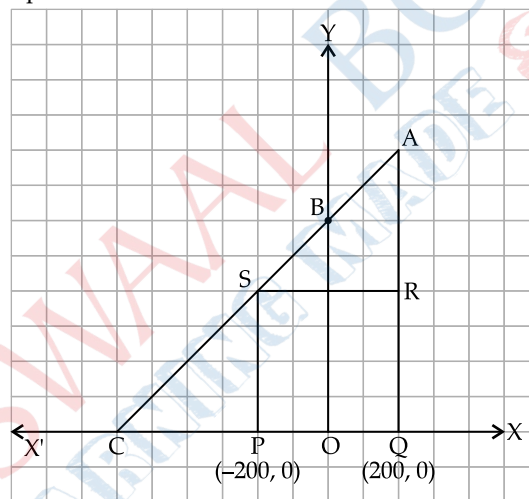

Based on the above information, answer the following questions:

- (i) Taking O as origin, coordinates of P are $(-200, 0)$ and of Q are $(200, 0)$. PQRS being a square, what are the coordinates of R and S?
- (ii) (a) What is the area of square PQRS ?
(b) What is the length of diagonal PR in square PQRS?
- (iii) If S divides CA in the ratio $K : 1$, what is the value of K, where point A is $(200, 800)$?

38. Governing council of a local public development authority of Dehradun decided to build an adventurous playground on the top of a hill, which will have adequate space for parking.

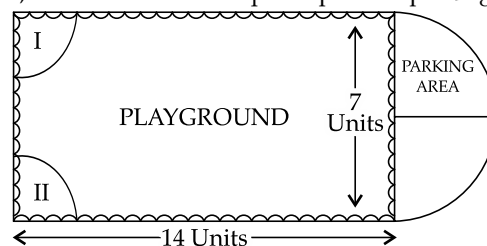

After survey, it was decided to build rectangular playground, with a semi-circular area allotted for parking at one end of the playground. The length and breadth of the rectangular playground are 14 units and 7 units, respectively. There are two quadrants of radius 2 units on one side for special seats.

Based on the above information, answer the following questions:

- (i) What is the total perimeter of the parking area?
 (ii) (a) What is the total area of parking and the two quadrants?

OR

- (b) What is the ratio of area of playground to the area of parking area?
 (iii) Find the cost of fencing the playground and parking area at the rate of ₹ 2 per unit.

Delhi Set-II

30/4/2

Note: Expect these, all other questions are from Delhi Set-I

SECTION — A

Section-A consists of Multiple Choice Type questions of 1 mark each

1. Which of the following is true for all values of θ ($0^\circ \leq \theta \leq 90^\circ$) ?
 (a) $\cos^2 \theta - \sin^2 \theta = 1$ (b) $\operatorname{cosec}^2 \theta - \sec^2 \theta = 1$
 (c) $\sec^2 \theta - \tan^2 \theta = 1$ (d) $\cot^2 \theta - \tan^2 \theta = 1$
2. If $k + 2$, $4k - 6$ and $3k - 2$ are three consecutive terms of an A.P., then the value of k is:
 (a) 3 (b) -3
 (c) 4 (d) -4
11. For the following distribution:

Class	0-5	5-10	10-15	15-20	20-25
Frequency	10	15	12	20	9

The sum of lower limits of median class and modal class is:

- (a) 15 (b) 25
 (c) 30 (d) 35
12. The length of tangent drawn to a circle of radius 9 cm from a point 41 cm from the centre is:
 (a) 40 cm (b) 9 cm
 (c) 41 cm (d) 50 cm
13. In the given figure, O is the centre of the circle and PQ is the chord. If the tangent PR at P makes an angle of 50° with PQ, then the measure of $\angle POQ$ is:

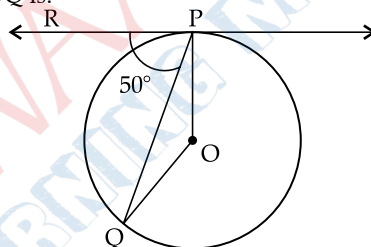

- (a) 50° (b) 40°
 (c) 100° (d) 130°
14. A bag contains 5 red balls and n green balls. If the probability of drawing a green balls is three times that of a red ball, then the value of n is:
 (a) 18 (b) 15
 (c) 10 (d) 20

SECTION — B

Section - B consists of Very Short Answer (VSA) type questions of 2 marks each.

21. (A) Evaluate: $\frac{5}{\cot^2 30^\circ} + \frac{1}{\sin^2 60^\circ} - \cot^2 45^\circ + 2 \sin^2 90^\circ$

OR

- (B) If θ is an acute angle and $\sin \theta = \cos \theta$, find the value of $\tan^2 \theta + \cot^2 \theta - 2$.

SECTION — C

Section - C consists of Short Answer (SA) type questions of 3 marks each.

29. (A) The sum of first 15 terms of an A.P. is 750 and its first term is 15. Find its 20th term.
 OR
 (B) Rohan repays hit total loan of ₹ 1,18,000 by paying every month starting with the first instalment of ₹ 1,000. If he increases the instalment by ₹ 100 every month, what amount will be paid by him in the 30th instalment ?
 What amount of loan has he paid after 30th instalment ?
30. Prove that $\sqrt{3}$ is an irrational number.

SECTION — D

Section - D consists of Long Answer (LA) type questions of 4 marks each.

32. From a solid cylinder of height 20 cm and diameter 12 cm, a conical cavity of height 8 cm and radius 6 cm is hallowed out. Find the total surface area of the remaining solid.
35. (A) In the given figure, $\angle ADC = \angle BCA$; prove that $\triangle ACB \sim \triangle ADC$. Hence find BD if $AC = 8$ cm and $AD = 3$ cm.

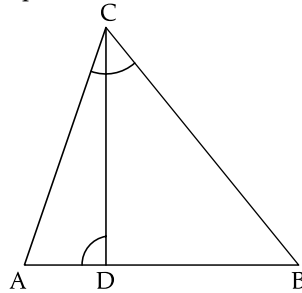

OR

- (B) If a line is drawn parallel to one side of a triangle to intersect the other two sides in distinct points, then prove that the other two sides are divided in the same ratio.

Delhi Set-III

30/4/3

Note: Expect these, all other questions are from Delhi Set-I & II

SECTION — A

Section-A consists of Multiple Choice Type questions of 1 mark each

7. The next term of the A.P.: $\sqrt{7}, \sqrt{28}, \sqrt{63}$ is:

- (a) $\sqrt{70}$ (b) $\sqrt{80}$
 (c) $\sqrt{97}$ (d) $\sqrt{112}$

8. $(\sec^2 \theta - 1)(\operatorname{cosec}^2 \theta - 1)$ is equal to:

- (a) -1 (b) 1
 (c) 0 (d) 2

15. For the following distribution:

Marks Below	10	20	30	40	50	60
Number of students	3	12	27	57	75	80

The modal class is:

- (a) 10 - 20 (b) 20 - 30
 (c) 30 - 40 (d) 50 - 60

16. In the given figure, PT is a tangent at T to the circle with centre O. If $\angle TPO = 25^\circ$, then x is equal to:

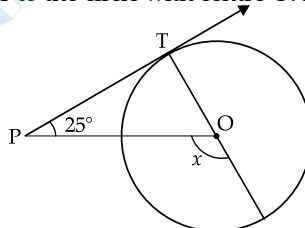

- (a) 25° (b) 65°
 (c) 90° (d) 115°

17. In the given figure, $PQ \parallel AC$. If $BP = 4$ cm, $AP = 2.4$ cm and $BQ = 5$ cm, then length of BC is:

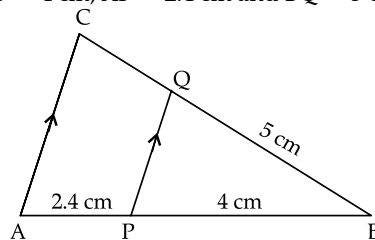

- (a) 8 cm (b) 3 cm
 (c) 0.3 cm (d) $\frac{25}{3}$ cm

18. The points $(-4, 0)$, $(4, 0)$ and $(0, 3)$ are the vertices of a:
- (a) right triangle (b) isosceles triangle
(c) equilateral triangle (d) scalene triangle

SECTION — B

Section - B consists of Very Short Answer (VSA) type questions of 2 marks each.

22. (A) Evaluate $2\sec^2 \theta + 3 \operatorname{cosec}^2 \theta - 2\sin \theta \cos \theta$ if $\theta = 45^\circ$.

OR

- (B) If $\sin \theta - \cos \theta = 0$, then find the value of $\sin^4 \theta + \cos^4 \theta$.

SECTION — C

Section - C consists of Short Answer (SA) type questions of 3 marks each.

26. Find the value of 'p' for which one root of the quadratic equation $px^2 - 14x + 8 = 0$ is 6 times the other.
27. From an external point, two tangents are drawn to a circle. Prove that the line joining the external point to the centre of the circle bisects the angle between the two tangents.

SECTION — D

Section - D consists of Long Answer (LA) type questions of 4 marks each.

32. (A) In a ΔPQR , N is a point on PR, such that $QN \perp PR$. If $PN \times NR = QN^2$, Prove that $\angle PQR = 90^\circ$.

OR

- (B) In the given figure, ΔABC and ΔDBC are on the same base BC. If AD intersects BC at O, prove that

$$\frac{\operatorname{ar}(\Delta ABC)}{\operatorname{ar}(\Delta DBC)} = \frac{AO}{DO}$$

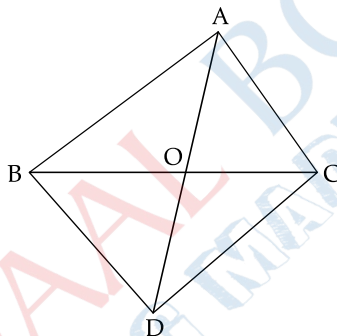

33. A wooden article was made by scooping out a hemisphere from each end of solid cylinder, as shown in the figure. If the height of the cylinder is 10 cm and its base is of radius 3.5 cm, find the total surface area of the article.



SECTION — A

Section-A consists of Multiple Choice Type questions of 1 mark each

- If $p^2 = \frac{32}{50}$, then p is a/an

(a) whole number (b) integer
(c) rational number (d) irrational number
- The distance of the point $(-6, 8)$ from x-axis is

(a) 6 units (b) -6 units
(c) 8 units (d) 10 units
- The number of quadratic polynomials having zeroes -5 and -3 is

(a) 1 (b) 2
(c) 3 (d) more than 3

4. The point of intersection of the line represented by $3x - y = 3$ and y -axis is given by
 (a) $(0, -3)$ (b) $(0, 3)$
 (c) $(2, 0)$ (d) $(-2, 0)$
5. The circumferences of two circles are in the ratio 4 : 5. What is the ratio of their radii ?
 (a) 16 : 25 (b) 25 : 16
 (c) $2 : \sqrt{5}$ (d) 4 : 5
6. If α and β are the zeroes of the polynomial $x^2 - 1$, then the value of $(\alpha + \beta)$ is
 (a) 2 (b) 1
 (c) -1 (d) 0

7. $\frac{\cos^2 \theta}{\sin^2 \theta} - \frac{1}{\sin^2 \theta}$, in simplified form is:

- (a) $\tan^2 \theta$ (b) $\sec^2 \theta$
 (c) 1 (d) -1
8. If $\Delta PQR \sim \Delta ABC$; $PQ = 6$ cm, $AB = 8$ cm and the perimeter of ΔABC is 36 cm, then the perimeter of ΔPQR is
 (a) 20.25 cm (b) 27 cm
 (c) 48 cm (d) 64 cm
9. If the quadratic equation $ax^2 + bx + c = 0$ has two real and equal roots, then 'c' is equal to
 (a) $-\frac{b}{2a}$ (b) $\frac{b}{2a}$
 (c) $-\frac{b^2}{4a}$ (d) $\frac{b^2}{4a}$

10. In the given figure, $DE \parallel BC$. If $AD = 3$ cm, $AB = 7$ cm and $EC = 3$ cm, then the length of AE is

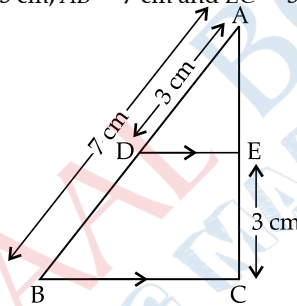

- (a) 2 cm (b) 2.25 cm
 (c) 3.5 cm (d) 4 cm
11. A bag contains 5 pink, 8 blue and 7 yellow balls. One ball is drawn at random from the bag. What is the probability of getting neither a blue nor a pink ball ?
 (a) $\frac{1}{4}$ (b) $\frac{2}{5}$
 (c) $\frac{7}{20}$ (d) $\frac{13}{20}$
12. The volume of a right circular cone whose area of the base is 156 cm^2 and the vertical height is 8 cm, is:
 (a) 2496 cm^3 (b) 1248 cm^3
 (c) 1664 cm^3 (d) 416 cm^3
13. 3 chairs and 1 table cost ₹ 900; whereas 5 chairs and 3 tables cost ₹ 2,100. If the cost of 1 chair is ₹ x and the cost of 1 table is ₹ y , then the situation can be represented algebraically as
 (a) $3x + y = 900, 3x + 5y = 2100$ (b) $x + 3y = 900, 3x + 5y = 2100$
 (c) $3x + y = 900, 5x + 3y = 2100$ (d) $x + 3y = 900, 5x + 3y = 2100$
14. In the given figure, PA and PB are tangents from external point P to a circle with centre C and Q is any point on the circle. Then the measure of $\angle AQB$ is

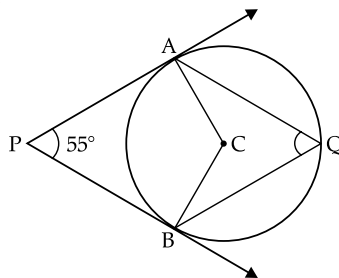

- (a) $62\frac{1}{2}^\circ$ (b) 125°
 (c) 55° (d) 90°
15. A card is drawn at random from a well shuffled deck of 52 playing cards. The probability of getting a face card is
- (a) $\frac{1}{2}$ (b) $\frac{3}{13}$
 (c) $\frac{4}{13}$ (d) $\frac{1}{13}$
16. If θ is an acute angle of a right angled triangle, then which of the following equation is not true ?
- (a) $\sin \theta \cot \theta = \cos \theta$ (b) $\cos \theta \tan \theta = \sin \theta$
 (c) $\operatorname{cosec}^2 \theta - \cot^2 \theta = 1$ (d) $\tan^2 \theta - \sec^2 \theta = 1$
17. If the zeroes of the quadratic polynomial $x^2(a+1)x+b$ are 2 and -3 , then
- (a) $a = -7, b = -1$ (b) $a = 5, b = -1$
 (c) $a = 2, b = -6$ (d) $a = 0, b = -6$
18. If the sum of the first n terms of an A.P. be $3n^2 + n$ and its common difference is 6, then its first term is
- (a) 2 (b) 3
 (c) 1 (d) 4

Assertion - Reason Based Questions: In the question number 19 and 20, a statement of Assertion (A) is followed by a statement of Reason (R). Choose the correct option out of the following:

- (a) Both Assertion (A) and Reason (R) are true and Reason (R) is the correct explanation of Assertion (A).
 (b) Both Assertion (A) and Reason (R) are true and Reason (R) is not the correct explanation of Assertion (A).
 (c) Assertion (A) is true but Reason (R) is false.
 (d) Assertion (A) is false but Reason (R) is true.
19. **Assertion (A):** If $5 + \sqrt{7}$ is a root of a quadratic equation with rational co-efficients, then its other root is $5 - \sqrt{7}$.
Reason (R): Surd roots of quadratic equation with rational co-efficients occur in conjugate pairs.
20. **Assertion (A):** For $0 < \theta \leq 90^\circ$, $\operatorname{cosec} \theta - \cot \theta$ and $\operatorname{cosec} \theta + \cot \theta$ are reciprocal of each other.
Reason (R): $\operatorname{cosec}^2 \theta - \cot^2 \theta = 1$

SECTION — B

Section - B consists of Very Short Answer (VSA) type questions of 2 marks each.

21. (A) Show that 6^n cannot end with digit 0 for any natural number 'n'.
 OR
 (B) Find the HCF and LCM of 72 and 120.
22. A line intersects y -axis and x -axis at point P and Q, respectively. If R(2, 5) is the mid-point of line segment PQ, then find the coordinates of P and Q.
23. Find the length of the shadow on the ground of a pole of height 18 m when angle of elevation θ of the sun is such that $\tan \theta = \frac{6}{7}$.
24. In the given figure, PA is a tangent to the circle drawn from the external point P and PBC is the secant to the circle with BC as diameter.
 If $\angle AOC = 130^\circ$, then find the measure of $\angle APB$, where O is the centre of the circle.

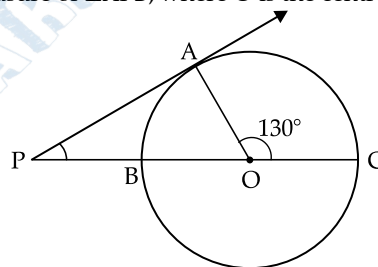

25. (A) In the given figure, ABC is a triangle in which $DE \parallel BC$. If $AD = x$, $DB = x - 2$, $AE = x + 2$ and $EC = x - 1$, then find the value of x .

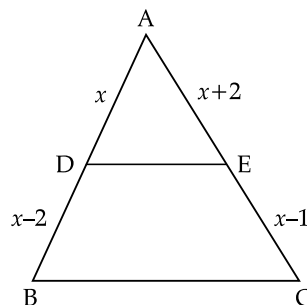

OR

- (B) Diagonals AC and BD of trapezium ABCD with $AB \parallel DC$ intersect each other at point O. Show that $\frac{OA}{OC} = \frac{OB}{OD}$.

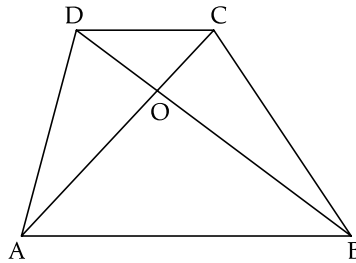

SECTION — C

Section - C consists of Short Answer (SA) type questions of 3 marks each.

26. Find the ratio in which the line segment joining the points A(6, 3) and B(-2, -5) is divided by x -axis.
 27. (A) Find the HCF and LCM of 26, 65 and 117, using prime factorisation.

OR

- (B) Prove that $\sqrt{2}$ is an irrational number.

28. In the given figure, E is a point on the side CB produced of an isosceles triangle ABC with $AB = AC$. If $AD \perp BC$ and $EF \perp AC$, then prove that $\triangle ABD \sim \triangle ECF$.

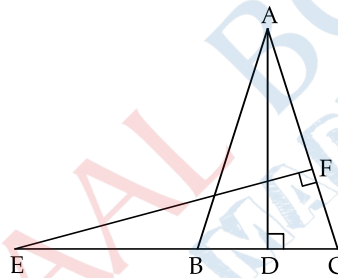

29. (A) The sum of two numbers is 15. If the sum of their reciprocals is $\frac{3}{10}$, find the two numbers.

OR

- (B) If α and β are roots of the quadratic equation $x^2 - 7x + 10 = 0$, find the quadratic equation whose roots are α^2 and β^2 .

30. Prove that: $\frac{1 + \sec A}{\sec A} = \frac{\sin^2 A}{1 - \cos A}$.

31. In a circle of radius 21 cm, an arc subtends an angle of 60° at the centre. Find the area of the sector formed by the arc. Also, find the length of the arc.

SECTION — D

Section - D consists of Long Answer (LA) type questions of 4 marks each.

32. (A) Two tangents TP and TQ are drawn to a circle with centre O from an external point T. Prove that $\angle PTQ = 2\angle OPQ$.

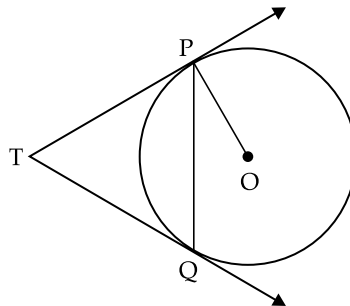

OR

- (B) A circle touches the side BC of a $\triangle ABC$ at a point P and touches AB and AC when produced at Q and R respectively. Show that $AQ = \frac{1}{2}$ (Perimeter of $\triangle ABC$).

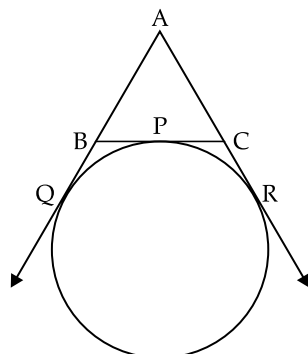

33. A solid is in the shape of a right-circular cone surmounted on a hemisphere, the radius of each of them being 7 cm and the height of the cone is equal to its diameter. Find the volume of the solid.
34. (A) The ratio of the 11th term to the 18th term of an A.P. is 2 : 3. Find the ratio of the 5th term to the 21st term. Also, find the ratio of the sum of first 5 terms to the sum of first 21 terms.

OR

- (B) If the sum of first 6 terms of an A.P. is 36 and that of the first 16 terms is 256, find the sum of first 10 terms.
35. 250 apples of a box were weighted and the distribution of masses of the apples is given in the following table:

Mass (in grams)	80–100	100–120	120–140	140–160	160–180
Number of apples	20	60	70	x	60

- (i) Find the value of x and the mean mass of the apples.
 (ii) Find the modal mass of the apples.

SECTION — E

Section - E consists of three Case Study Based questions of 4 marks each.

36. A coaching institute of Mathematics conducts classes in two batches I and II and fees for rich and poor children are different. In batch I, there are 20 poor and 5 rich children, whereas in batch II, there are 5 poor and 25 rich children. The total monthly collection of fees from batch I is ₹ 9000 and from batch II is ₹ 26,000. Assume that each poor child pays ₹ x per month and each rich child pays ₹ y per month.



Based on the above information, answer the following questions:

- (i) Represent the information given above in terms of x and y .
 (ii) Find the monthly fee paid by a poor child.

OR

Find the difference in the monthly fee paid by a poor child and a rich child.

(iii) If there are 10 poor and 20 rich children in batch II, what is the total monthly collection of fees from batch II?

37. Radio towers are used for transmitting a range of communication services including radio and television. The tower will either act as an antenna itself or support one or more antennas on its structure. On a similar concept, a radio station tower was built in two Sections A and B. Tower is supported by wires from a point O.

Distance between the base of the tower and point O is 36 cm. From point O, the angle of elevation of the top of the Section B is 30° and the angle of elevation of the top of Section A is 45° .

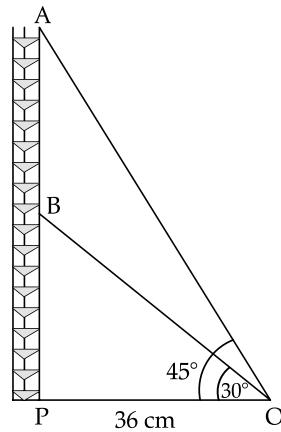

Based on the above information, answer the following questions:

- (i) Find the length of the wire from the point O to the top of section B.
- (ii) Find the distance AB.

OR

Find the area of $\triangle OPB$.

(iii) Find the height of the Section A from the base of the tower.

38. "Eight Ball" is a game played on a pool table with 15 balls numbered 1 to 15 and a "cue ball" that is solid and white. Of the 15 numbered balls, eight are solid (non-white) coloured and numbered 1 to 8 and seven are striped balls numbered 9 to 15.

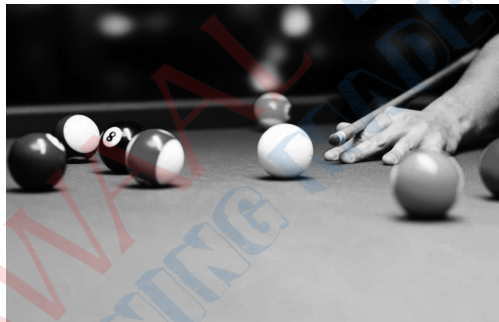

The 15 numbered pool balls (no cue ball) are placed in a large bowl and mixed, then one ball is drawn out at random.

Based on the above information, answer the following question:

- (i) What is the probability that the drawn ball bears number 8?
- (ii) What is probability that the drawn ball bears an even number?

OR

What is the probability that the drawn ball bears a number, which is a multiple of 3?

(iii) What is the probability that the drawn ball is a solid coloured and bears an even number?

Note: Expect these, all other questions are from Outside Delhi Set-I

SECTION — A

Section-A consists of Multiple Choice Type questions of 1 mark each

6. The LCM of smallest 2-digit number and smallest composite number is
 - (a) 12
 - (b) 4
 - (c) 20
 - (d) 40
8. If one zero of the polynomial $x^2 + 3x + k$ is 2, then the value of k .
 - (a) -10
 - (b) 10
 - (c) 5
 - (d) -5

16. A box contains 90 discs, numbered from 1 to 90. If one disc is drawn at random from the box, the probability that it bears a prime number less than 23 is
- (a) $\frac{7}{90}$ (b) $\frac{1}{9}$
 (c) $\frac{4}{45}$ (d) $\frac{9}{89}$
17. The coordinates of the point where the line $2y = 4x + 5$ crosses x -axis is
- (a) $\left(0, \frac{-5}{4}\right)$ (b) $\left(0, \frac{5}{2}\right)$
 (c) $\left(\frac{-5}{4}, 0\right)$ (d) $\left(\frac{-5}{2}, 0\right)$
18. $(\cos^4 A - \sin^4 A)$ on simplification, gives
- (a) $2 \sin^2 A - 1$ (b) $2 \sin^2 A + 1$
 (c) $2 \cos^2 A + 1$ (d) $2 \cos^2 A - 1$

SECTION — B

Section - B consists of Very Short Answer (VSA) type questions of 2 marks each.

24. Find the points on the x -axis, each of which is at a distance of 10 units from the point $A(11, -8)$.

SECTION — C

Section - C consists of Short Answer (SA) type questions of 3 marks each.

26. In the given figure, AB and CD are diameters of a circle with centre O perpendicular to each other. If $OA = 7$ cm, find the area of shaded region.

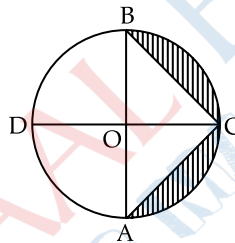

27. If $\sin \theta + \cos \theta = p$ and $\sec \theta + \operatorname{cosec} \theta = q$, then prove that $q(p^2 - 1) = 2p$.

SECTION — D

Section - D consists of Long Answer (LA) type questions of 4 marks each.

35. (A) Find the sum of integers between 100 and 200 which are (i) divisible by 9 (ii) not divisible by 9.
OR

(B) Solve the equation:

$$-4 + (-1) + 2 + 5 + \dots + x = 437.$$

Outside Delhi Set-III

30/6/3

Note: Expect these, all other questions are from Outside Delhi Set-I and Set-II

SECTION — A

Section-A consists of Multiple Choice Type questions of 1 mark each

1. The distance between the points $(0, 5)$ and $(-3, 1)$ is:
- (a) 8 units (b) 5 units
 (c) 3 units (d) 25 units
2. If $\tan \theta = \frac{x}{y}$, then $\cos \theta$ is equal to
- (a) $\frac{x}{\sqrt{x^2 + y^2}}$ (b) $\frac{y}{\sqrt{x^2 + y^2}}$
 (c) $\frac{x}{\sqrt{x^2 - y^2}}$ (d) $\frac{y}{\sqrt{x^2 - y^2}}$
3. The zeroes of the polynomial $3x^2 + 11x - 4$ are:
- (a) $\frac{1}{3}, -4$ (b) $-\frac{1}{3}, 4$
 (c) $\frac{1}{3}, 4$ (d) $-\frac{1}{3}, -4$

7. If $p^2 = \frac{32}{50}$, then p is a/an

- (a) whole number (b) integer
(c) rational number (d) irrational number

17. Cards bearing numbers 3 to 20 are placed in a bag and mixed thoroughly. A card is taken out of the bag at random. What is the probability that the number on the card taken out is an even number?

- (a) $\frac{9}{17}$ (b) $\frac{1}{2}$
(c) $\frac{5}{9}$ (d) $\frac{7}{18}$

18. The condition for the system of linear equations $ax + by = c$; $lx + my = n$ to have a unique solution is

- (a) $am \neq bl$ (b) $al \neq bm$
(c) $al = bm$ (d) $am = bl$

SECTION — B

Section - B consists of Very Short Answer (VSA) type questions of 2 marks each.

21. Find the ratio in which the y -axis divides the line segment joining the points $(5, -6)$ and $(-1, -4)$.

SECTION — C

Section - C consists of Short Answer (SA) type questions of 3 marks each.

26. Prove that $(\sin \theta + \cos \theta)(\tan \theta + \cot \theta) = \sec \theta + \operatorname{cosec} \theta$.

27. (A) A natural number, when increased by 12, equals 160 times its reciprocal. Find the number.

OR

(B) If one root of the quadratic equation $x^2 + 12x - k = 0$ is thrice the other root, then find the value of k .

29. In a circle of radius 21 cm, an arc subtends an angle of 60° at the centre. Find the area of the sector formed by the arc. Also, find the length of the arc.

31. (A) Find the HCF and LCM of 26, 65 and 117, using prime factorisation.

OR

(B) Prove that $\sqrt{2}$ is an irrational number.

SECTION — D

Section - D consists of Long Answer (LA) type questions of 4 marks each.

32. (A) The sum of first seven terms of an A.P. is 182. If its 4th term and the 17th term are in the ratio 1 : 5, find the A.P.

OR

(B) The sum of first q terms of an A.P. is $63q - 3q^2$. If its p^{th} term is -60 , find the value of p . Also, find the 11th term of this A.P.

33. (A) Prove that a parallelogram circumscribing a circle is a rhombus.

OR

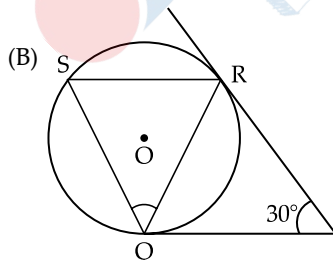

In the given figure, tangents PQ and PR are drawn to a circle such that $\angle RPQ = 30^\circ$. A chord RS is drawn parallel to the tangent PQ . Find the measure of $\angle RQS$.

ANSWERS

Delhi Set-I

30/4/1

SECTION — A

1. Option (a) is correct

Explanation: Least composite number is 4 and the least prime number is 2.

$$\text{HCF}(4, 2) : \text{LCM}(4, 2) = 2 : 4 = 1 : 2$$

2. Option (a) is correct

Explanation:

$$x^2 + 3x - 10 = 0$$

$$x^2 + 5x - 2x - 10 = 0$$

$$x(x + 5) - 2(x + 5) = 0$$

$$\therefore x = 2 \text{ and } x = -5$$

3. Option (b) is correct

Explanation: First term, $a_1 = \sqrt{6}$

$$\text{Second term, } a_2 = \sqrt{24} = 2\sqrt{6}$$

$$\text{Common difference} = 2\sqrt{6} - \sqrt{6}$$

$$= \sqrt{6}(2-1) = \sqrt{6}$$

Next term of A.P is = Third term

+ common difference

$$= \sqrt{54} + \sqrt{6}$$

$$= 3\sqrt{6} + \sqrt{6}$$

$$= 4\sqrt{6} = \sqrt{96}$$

4. Option (b) is correct

Explanation:

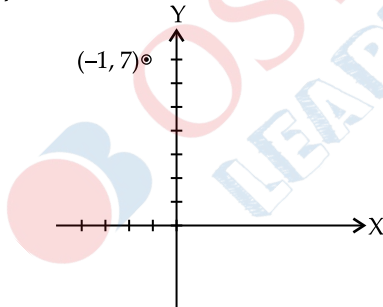

The distance of $(-1, 7)$ from x -axis is 7 units.

5. Option (c) is correct

Explanation: Given, diameter of semi-circle = d

$$\therefore \text{radius of semi-circle} = \frac{d}{2}$$

$$\begin{aligned} \text{Therefore area of semi-circle} &= \frac{\pi \left(\frac{d}{2}\right)^2}{2} \\ &= \frac{\pi d^2}{8} \end{aligned}$$

6. Option (a) is correct

Explanation: Empirical formula

$$\text{Mode} = 3 \text{ Median} - 2 \text{ Mean}$$

7. Option (c) is correct

Explanation: Given equations can be rewrite as:

$$2x - 5y - 6 = 0$$

$$6x - 15y - 18 = 0$$

$$\frac{a_1}{a_2} = \frac{2}{6} = \frac{1}{3}$$

$$\frac{b_1}{b_2} = \frac{-5}{-15} = \frac{1}{3}$$

$$\text{This shows: } \frac{c_1}{c_2} = \frac{-6}{-18} = \frac{1}{3}$$

Therefore, the pair of equations has infinitely many solutions. Graphically pair of linear equations represent coincident.

8. Option (d) is correct

Explanation: Given polynomial:

$$x^2 - 1 = (x-1)(x+1)$$

For zeroes, $(x-1)(x+1) = 0$

$$\therefore x = 1 \text{ and } x = -1$$

Let $\alpha = 1$ and $\beta = -1$

$$\text{Sum of } \alpha + \beta = 1 + (-1) = 0$$

9. Option (a) is correct

Explanation:

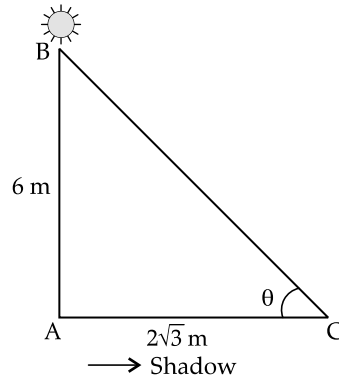

$$\tan \theta = \frac{AB}{AC}$$

$$\tan \theta = \frac{6}{2\sqrt{3}}$$

$$\tan \theta = \frac{3}{\sqrt{3}}$$

$$\tan \theta = \sqrt{3}$$

$$\tan \theta = \tan 60^\circ$$

$$\therefore \theta = 60^\circ$$

10. Option (c) is correct

Explanation: We know that

$$\begin{aligned}\sec \theta &= \frac{1}{\cos \theta} \\ &= \frac{\sin \theta}{\cos \theta} \cdot \frac{1}{\sin \theta} \\ &= \frac{1}{\cot \theta} \operatorname{cosec} \theta \\ &= \frac{\sqrt{1 + \cot^2 \theta}}{\cot \theta} \\ &[\because \operatorname{cosec}^2 \theta = 1 + \cot^2 \theta]\end{aligned}$$

11. Option (c) is correct

Explanation: Total number of possible outcomes
= 36 = n(s)

Favourable outcomes to get difference of number on the dice as 3 are:

(1, 4), (2, 5), (3, 6), (4, 1), (5, 2), (6, 3)

$$\therefore n(E) = 6$$

$$\begin{aligned}\text{Required Probability} &= \frac{n(E)}{n(S)} \\ &= \frac{6}{36} = \frac{1}{6}\end{aligned}$$

12. Option (b) is correct

Explanation:

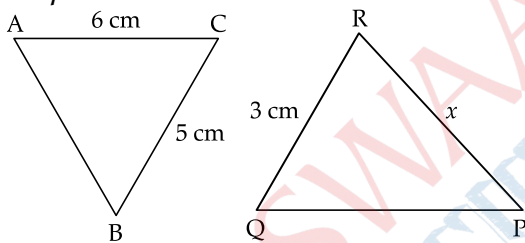

Given,

$$\triangle ABC \sim \triangle QPR$$

$$\begin{aligned}\therefore \frac{AB}{QP} &= \frac{BC}{PR} = \frac{AC}{QR} \\ \Rightarrow \frac{AB}{QP} &= \frac{5}{x} = \frac{6}{3}\end{aligned}$$

Equating last two, we get

$$\begin{aligned}x &= \frac{5 \times 3}{6} \\ &= \frac{5}{2} = 2.5 \text{ cm}\end{aligned}$$

13. Option (d) is correct

Explanation: Distance between (-6, 8) and (0, 0) is

$$\begin{aligned}a &= \sqrt{(-6-0)^2 + (8-0)^2} \\ &= \sqrt{36 + 64} \\ &= \sqrt{100} \\ &= 10\end{aligned}$$

14. Option (b) is correct

Explanation:

Here, $\angle OQP = 90^\circ$ (angle between radius and tangent)

Now, in $\triangle OQP$,

$$\begin{aligned}\angle OQP + \angle QOP + \angle OPQ &= 180^\circ \\ 90^\circ + y + x &= 180^\circ \\ \Rightarrow x + y &= 90^\circ\end{aligned}$$

15. Option (a) is correct

Explanation:

Here, $\angle OAT = 90^\circ$ (angle between tangent and radius)

In $\triangle OAT$,

$$\begin{aligned}\cos 30^\circ &= \frac{TA}{OT} \\ \Rightarrow \frac{\sqrt{3}}{2} &= \frac{TA}{4} \\ \Rightarrow TA &= \frac{4\sqrt{3}}{2} = 2\sqrt{3} \text{ cm}\end{aligned}$$

16. Option (b) is correct

Explanation: As $PQ \parallel BC$ by using basic proportionality theorem,

$$\begin{aligned}\frac{AP}{PB} &= \frac{AQ}{QC} \\ \Rightarrow \frac{4}{6} &= \frac{8}{QC} \\ \Rightarrow QC &= \frac{8 \times 6}{4} \\ \Rightarrow QC &= 12 \text{ cm} \\ \text{Now, } AC &= AQ + QC \\ &= 8 + 12 = 20 \text{ cm}\end{aligned}$$

17. Option (d) is correct

Explanation: For zeroes of polynomial, put $p(x) = 0$

$$\begin{aligned}4x^2 - 3x - 7 &= 0 \\ 4x^2 - 7x + 4x - 7 &= 0 \\ x(4x - 7) + 1(4x - 7) &= 0 \\ (4x - 7)(x + 1) &= 0\end{aligned}$$

$$\therefore x = \frac{7}{4} \text{ and } x = -1$$

$$\text{Let } \alpha = \frac{7}{4} \text{ and } \beta = -1$$

$$\begin{aligned}\therefore \frac{1}{\alpha} + \frac{1}{\beta} &= \frac{4}{7} + \frac{1}{(-1)} \\ &= \frac{4}{7} - 1 = \frac{-3}{7}\end{aligned}$$

18. Option (d) is correct

Explanation: No. of ace cards in a pack of 52 cards = 4

\therefore No. of non-ace cards in a pack of 52 cards = 48

$$\text{Required probability} = \frac{48}{52} = \frac{12}{13}$$

19. Option (c) is correct

Explanation: Assertion: A week has 7 days and total days are 366

Number of Sundays in a leap year = 52 Sundays + 2 days

Therefore, probability of leap year with 53 Sundays = $\frac{2}{7}$

Reason: There are 52 Sundays in a non-leap year. But one left over days apart from those 52 weeks can be either a Monday, Tuesday, Wednesday, Thursday, Friday, Saturday or Sunday.

$$\therefore \text{Required probability} = \frac{1}{7}$$

20. Option (b) is correct

Explanation: Assertion is true because

$$b - a = c - b \quad (a, b, c \text{ are in A.P.})$$

$$\Rightarrow 2b = a + c$$

Reason: Let $1 + 3 + 5 + 7 + 9 + \dots + n$, are sum of n odd natural numbers.

$$\therefore S_n = \frac{n}{2} [2a + (n-1)d]$$

$$S_n = \frac{n}{2} [2(1) + (n-1)2]$$

$$S_n = \frac{n}{2} (2n)$$

$$S_n = n^2$$

Hence, the sum of the first n odd natural number is n^2 .

SECTION — B

21. We know that,

$$\text{LCM} \times \text{HCF} = a \times b \quad (a, b \text{ are two numbers})$$

...(i)

Let numbers = $2x$ and $3x$

$$\therefore \text{LCM} = 2 \times 3 \times x = 6x$$

$$\therefore 6x = 180$$

$$\therefore x = 30$$

Numbers are:

$$2 \times 30 = 60 \text{ and } 3 \times 30 = 90 \quad \mathbf{1}$$

From eq (i), $180 \times \text{HCF} = 60 \times 90$

$$\text{HCF} = \frac{60 \times 90}{180} = 30 \quad \mathbf{1}$$

Therefore, $\text{HCF} = 30$

22. Let the zeroes of polynomials are α and $\frac{1}{\alpha}$.

$$\text{product of zeroes} = \frac{-(k-2)}{6}$$

$$\Rightarrow \alpha \times \frac{1}{\alpha} = \frac{-(k-2)}{6} \quad \mathbf{1}$$

$$\Rightarrow 6 = -(k-2)$$

$$\Rightarrow k = 2 - 6$$

$$\Rightarrow k = -4$$

Therefore, value of k is -4 . $\mathbf{1}$

23. (A) Given quadratic equation is $2x^2 - 9x + 4 = 0$

$$\text{Sum of roots} = \frac{-(-9)}{2} = \frac{9}{2} \quad \mathbf{1}$$

$$\text{Product of roots} = \frac{4}{2} = 2 \quad \mathbf{1}$$

[For quadratic equation $ax^2 + bx + c = 0$, sum of

$$\text{roots} = \frac{-b}{a} \text{ and product of roots} = \frac{c}{a}]$$

OR

(B) Given quadratic equation is $4x^2 - 5 = 0$

$$\text{Q discriminant, } D = b^2 - 4ac \quad \frac{1}{2}$$

$$\therefore D = 0 - 4(4)(-5)$$

$$D = 80$$

Thus, discriminant $D = 80$ $\frac{1}{2}$

Since, $D > 0$, then roots are real and distinct. $\mathbf{1}$

24. When a coin is tossed two times.

The possible outcomes are {TT, HH, TH, HT}

$$\therefore n(S) = 4 \quad \frac{1}{2}$$

Favourable outcomes = {HH, HT, TH}

$$\therefore n(E) = 3 \quad \frac{1}{2}$$

$$\text{Required probability} = \frac{n(E)}{n(S)} = \frac{3}{4} \quad \mathbf{1}$$

25. (A) We have, $\frac{5 \cos^2 60^\circ + 4 \sec^2 30^\circ - \tan^2 45^\circ}{\sin^2 30^\circ + \cos^2 30^\circ}$

$$= \frac{5 \left(\frac{1}{2}\right)^2 + 4 \left(\frac{2}{\sqrt{3}}\right)^2 - (1)^2}{\left(\frac{1}{2}\right)^2 + \left(\frac{\sqrt{3}}{2}\right)^2} \quad \mathbf{1}$$

$$= \frac{5 + \frac{16}{3} - 1}{\frac{1}{4} + \frac{3}{4}}$$

$$= \frac{5 + \frac{16}{3} - 1}{1}$$

$$= \frac{15 + 64 - 12}{12} = \frac{67}{12} \quad \mathbf{1}$$

OR

(B) Given $\sin(A - B) = 0$ and $2 \cos(A + B) - 1 = 0$

$$\sin(A - B) = 0$$

$$\text{and } 2 \cos(A + B) - 1 = 0$$

$$\Rightarrow \sin(A - B) = \sin 0^\circ$$

$$\text{and } \cos(A + B) = \frac{1}{2} \quad \mathbf{1}$$

$$\Rightarrow A - B = 0^\circ \quad \dots(i)$$

$$\text{and } \cos(A + B) = \cos 60^\circ$$

$$\text{and } A + B = 60^\circ \quad \dots(ii)$$

On solving eqs (i) and (ii), we get

$$A = 30^\circ \text{ and } B = 30^\circ \quad \mathbf{1}$$

SECTION — C

26. (A) Given, first term (a) = -14 , fifth term (a_5) = 2 and last term (a_n) = 62 $\mathbf{1}$

Let common difference be d .

$$\therefore a_5 = a + 4d$$

$$\Rightarrow 2 = -14 + 4d$$

$$\Rightarrow d = 4 \quad \dots(i) \quad \mathbf{1}$$

$$a_n = a + (n-1)d$$

$$\Rightarrow 62 = -14 + (n-1)4 \quad [\text{From eq (i)}]$$

$$\Rightarrow n-1 = 19$$

$$\Rightarrow n = 20 \quad \mathbf{1}$$

Thus, number of terms in A.P. are 20

OR

- (B) Given A.P. is 65, 61 57, 53, ...
 Here, first term, $a = 65$
 common difference, $d = -4$ $\frac{1}{2}$
 Let the n th term of the given A.P. be the first negative term.
 $\therefore a_n < 0$ $\frac{1}{2}$
 $\Rightarrow a + (n-1)d < 0$
 $\Rightarrow 65 + (n-1)(-4) < 0$
 $\Rightarrow 69 - 4n < 0$
 $\Rightarrow -4n < -69$
 $\Rightarrow n > \frac{69}{4}$
 $\Rightarrow n > 17\frac{1}{4}$ 1

Since, 18 is the natural number just greater than $17\frac{1}{4}$

So, $n = 18$
 Hence, 18th term is first negative term. 1

27. We prove this by using the method of contradiction.
 Assume that $\sqrt{5}$ is a rational number.

Then, $\sqrt{5} = \frac{a}{b}$
 (where HCF $(a, b) = 1$) ... (i) 1

$\sqrt{5} = \frac{a}{b}$
 $\Rightarrow a = \sqrt{5}b$
 $\Rightarrow a^2 = 5b^2$ ($b \neq 0$)

Since, a^2 is a multiple of 5, So a is also a multiple of 5.

Let $a = 5m$
 $(5m)^2 = 5b^2$
 $\Rightarrow 25m^2 = 5b^2$
 $\Rightarrow b^2 = 5m^2$ $\frac{1}{2}$

Since b^2 is a multiple of 5, so, b is also a multiple of 5.

Let $b = 5n$
 Thus, HCF of $(a, b) = 5$... (ii) 1

From eqs. (i) and (ii), we get that our assumption was wrong.

Therefore $\sqrt{5}$ is not a rational number it is an irrational number $\frac{1}{2}$

28. **Given:** PA and PB are the tangent drawn from a point P to a circle with centre O

Also, the line segments OA and OB are drawn.

To prove: $\angle APB + \angle AOB = 180^\circ$ 1

Proof: We know that the tangents to a circle is perpendicular to the radius through the points of contact.

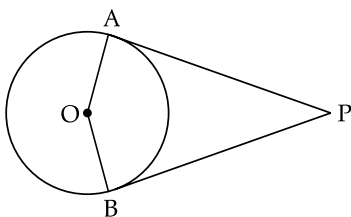

$\therefore PA \perp OA \Rightarrow \angle OAP = 90^\circ$
 and $PB \perp OB \Rightarrow \angle OBP = 90^\circ$ 1
 Therefore, $\angle OAP + \angle OBP = 180^\circ$
 Hence $\angle APB + \angle AOB = 180^\circ$
 [Sum of the all the angles of a quadrilateral is 360°] 1

29. (A) L.H.S. = $\frac{\sin A - 2\sin^3 A}{2\cos^3 A - \cos A}$ 1
 $= \frac{\sin A(1 - 2\sin^2 A)}{\cos A(2\cos^2 A - 1)}$ 1
 $= \frac{\sin A[1 - 2\sin^2 A]}{\cos A[2(1 - \sin^2 A) - 1]}$ 1
 $= \frac{\sin A(1 - 2\sin^2 A)}{\cos A(1 - 2\sin^2 A)}$ 1
 $= \tan A$ 1
 $= \text{R.H.S.}$

\therefore L.H.S = R.H.S Hence Proved

OR

(B) L.H.S = $\sec A(1 - \sin A)(\sec A + \tan A)$
 $= \left(\sec A - \frac{\sin A}{\cos A} \right) (\sec A + \tan A)$
 $\left[\because \sec A = \frac{1}{\cos A} \right]$ 1
 $= (\sec A - \tan A) (\sec A + \tan A)$
 $= \sec^2 A - \tan^2 A$ 1
 $= (1 + \tan^2 A) - \tan^2 A$
 $= 1$ 1
 $= \text{R.H.S.}$ Hence Proved

30. Let the two concentric circles with centres O.
 Let AB be the chord of the larger circle which touches the smaller circle at point P.

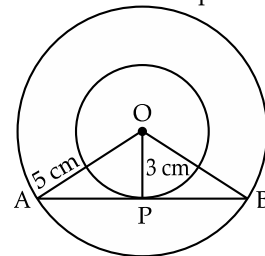

Therefore, AB is tangent to the smaller circle to the point P.

$\therefore OP \perp AB$
 In $\triangle OPA$, $AO^2 = OP^2 + AP^2$
 $(5)^2 = (3)^2 + AP^2$
 $AP^2 = 25 - 9$
 $\therefore AP = 4 \text{ cm}$ 1

Now, in $\triangle OPB$,
 $OP \perp AB$
 $\therefore AP = PB$ 1
 (Perpendicular from the centre of the circle bisects the chord)

Thus, $AB = 2AP$
 $= 2 \times 4$
 $= 8 \text{ cm}$ 1

Hence, length of the chord of the larger circle is 8 cm.

31. For equal roots, discriminant = 0
 i.e., $b^2 - 4ac = 0$... (i)
 Given equation is $px(x-2) + 6 = 0$
 i.e., $px^2 - 2px + 6 = 0$
 here, $a = p, b = -2p$ and $c = 6$
 (On comparing with $ax^2 + bx + c = 0$)
 From eq. (i) $(-2p)^2 - 4(p)(6) = 0$
 $4p^2 - 24p = 0$
 $4p^2 = 24p$
 $p^2 = 6p$
 $p^2 - 6p = 0$
 $p(p-6) = 0$
 $p = 0$ or $p = 6$
 $\therefore p = 6$
 (\because If $p = 0$, then given equation is not quadratic equation)

SECTION — D

32. (A) Let AB be the tower C is the position of first car and D is the position of second car. CD is the distance between two cars. 1

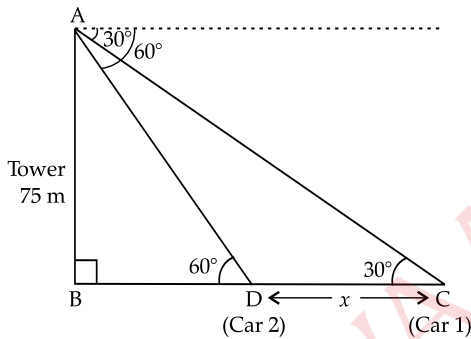

In right $\triangle ABC$,

$$\tan 30^\circ = \frac{AB}{BC}$$

$$\frac{1}{\sqrt{3}} = \frac{75}{BD + x}$$

$$\therefore BD + x = 75\sqrt{3} \quad \dots(i) \quad 1$$

In right $\triangle ABD$,

$$\tan 60^\circ = \frac{AB}{BD}$$

$$\sqrt{3} = \frac{75}{BD}$$

$$BD = \frac{75}{\sqrt{3}} \quad \dots(ii) \quad 1$$

From eqs. (i) and (ii), we get

$$\frac{75}{\sqrt{3}} + x = 75\sqrt{3}$$

$$\Rightarrow x = 75\sqrt{3} - \frac{75}{\sqrt{3}}$$

$$\Rightarrow x = 75\sqrt{3} - \frac{75\sqrt{3}}{3}$$

$$\Rightarrow x = 75\sqrt{3} \left(1 - \frac{1}{3}\right)$$

$$\Rightarrow x = 75\sqrt{3} \times \frac{2}{3}$$

$$\Rightarrow x = \frac{150}{\sqrt{3}}$$

$$\Rightarrow x = \frac{150}{1.73}$$

$$\Rightarrow x = 86.705$$

$$\Rightarrow x = 86.71 \text{ m} \quad 2$$

OR

- (B) Let AB be the building of height 7 m and EC be the height of the tower.

A is the point from where elevation of tower is 60° and the angle of depression of its foot is 45° .

$$EC = DE + CD$$

$$\text{Also, } CD = AB = 7 \text{ m and } BC = AD \quad 1$$

In right $\triangle ABC$,

$$\tan 45^\circ = \frac{AB}{BC}$$

$$1 = \frac{7}{BC}$$

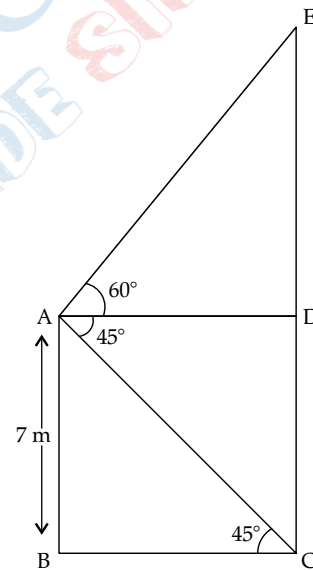

$$BC = 7 \quad 1$$

$$\text{Since, } BC = AD$$

$$\text{So, } AD = 7 \text{ m}$$

In right $\triangle ADE$,

$$\tan 60^\circ = \frac{DE}{AD}$$

$$\sqrt{3} = \frac{DE}{7}$$

$$\therefore DE = 7\sqrt{3} \text{ cm} \quad 1$$

$$\text{Hence, } EC = CD + ED$$

$$= 7 + 7\sqrt{3}$$

$$= 7(1 + \sqrt{3})$$

$$= 7(1 + 1.732)$$

$$= 7 \times 2.732$$

$$= 19.124 \text{ m}$$

$$\sim 19 \text{ m} \quad 2$$

Thus, height of the tower is approximately 19 m.

33. (A) **Given:** D is the point on the side BC of ΔABC such that $\angle ADC = \angle BAC$

To prove: $CA^2 = CB \cdot CD$

Proof: From ΔADC and ΔBAC ,

$$\angle ADC = \angle BAC \quad (\text{Given})$$

$$\angle ACD = \angle BCA \quad (\text{common angle})$$

$$\therefore \Delta ADC \sim \Delta BAC$$

(By AA similarity criterion) 2

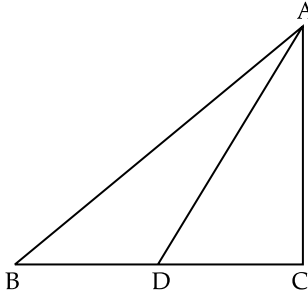

We know that, the corresponding sides of similar triangles are in proportion. 1

$$\therefore \frac{CA}{CB} = \frac{CD}{CA}$$

$$\Rightarrow CA^2 = CB \cdot CD \quad \text{Hence Proved 2}$$

OR

(B) **Given,** $\Delta ABC \sim \Delta PQR$

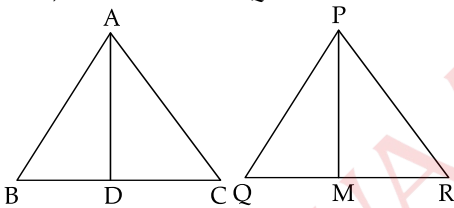

We know that the corresponding sides of similar triangles are in proportion.

$$\therefore \frac{AB}{PQ} = \frac{AC}{PR} = \frac{BC}{QR} \quad \dots(i) \quad 1$$

$$\text{Also, } \angle A = \angle P, \angle B = \angle Q, \angle C = \angle R \quad \dots(ii) \quad 1$$

Since AD and PM are medians, they will divide opposite sides.

$$\therefore BD = \frac{BC}{2} \text{ and } QM = \frac{QR}{2} \quad \dots(iii) \quad 1$$

From eqs. (i) and (ii), we get $\frac{1}{2}$

35. We have,

$$24 + 40 + 33 + x + 30 + 22 + 16 + 7 = 200$$

$$x + 172 = 200$$

$$\therefore x = 28 \quad 1$$

Expenditure (in ₹)	No. of families (f_i)	Cumulative frequency ($c.f.$)	x_i	$d_i = x_i - 2750$	$u_i = \frac{x - 2750}{h}$	$f_i u_i$
1000 – 1500	24	24	1250	-1500	-3	-72
1500 – 2000	40	64	1750	-1000	-2	-80
2000 – 2500	33	97	2250	-500	-1	-33
2500 – 3000	28	125	2750	0	0	0
3000 – 3500	30	155	3250	500	1	30
3500 – 4000	22	177	3750	1000	2	44
4000 – 4500	16	193	4250	1500	3	48
4500 – 5000	7	200	4750	2000	4	28
Total	200					-35

$$\frac{AB}{PQ} = \frac{BD}{QM} \quad \dots(iv)$$

In ΔABD and ΔPQM ,

$$\angle B = \angle Q \quad [\text{using eq. (ii)}]$$

$$\frac{AB}{PQ} = \frac{BD}{QM}$$

$$\therefore \Delta ABD \sim \Delta PQM$$

(By SAS similarity criterion) 1

$$\text{Thus, } \frac{AB}{PQ} = \frac{BD}{QM} = \frac{AD}{PM}$$

$$\text{Hence, } \frac{AB}{PQ} = \frac{AD}{PM}$$

Hence Proved 1

34. We have,

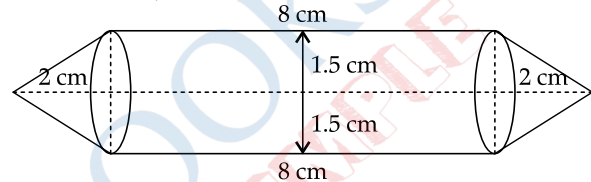

$$\text{Height of cylinder} = 12 - 4 = 8 \text{ cm}$$

$$\text{Radius of cone/cylinder} = \frac{3}{2} = 1.5 \text{ cm}$$

$$\text{Height of cone} = 2 \text{ cm} \quad 1$$

$$\begin{aligned} \text{Volume of cylinder} &= \pi r^2 h \\ &= \pi (1.5)^2 \times 8 \\ &= 18\pi \text{ cm}^3 \quad 1 \end{aligned}$$

$$\begin{aligned} \text{Volume of cone} &= \frac{1}{3} \pi r^2 h \\ &= \frac{1}{3} \pi (1.5)^2 \times 2 \\ &= 1.5\pi \text{ cm}^3 \quad 1 \end{aligned}$$

$$\begin{aligned} \text{Total volume} &= \text{Volume of cylinder} \\ &\quad + (\text{Volume of cone}) \times 2 \quad 1 \\ &= 18\pi + 1.5\pi \times 2 \\ &= 18\pi + 3\pi \\ &= 21\pi \\ &= 21 \times \frac{22}{7} \\ &= 66 \text{ cm}^3. \quad 1 \end{aligned}$$

[\because Total no. of families = 200]

For mean

From table, $\sum f_i = 200$, $\sum f_i u_i = -35$, $h = 500$, $A = 2750$

$$\begin{aligned} \therefore \text{Mean } (\bar{x}) &= A + \left(\frac{\sum f_i u_i}{\sum f_i} \right) \times h \\ &= 2750 + \left(\frac{-35}{200} \right) \times 500 \\ &= 2750 - 87.5 \\ &= 2662.5 \end{aligned} \quad 2$$

So, the mean monthly expenditure was ₹ 2662.50.

For median

From table, $\sum f_i = N = 200$, then $\frac{N}{2} = \frac{200}{2} = 100$,

which lies in interval 2500 – 3000.

Median class : 2500 – 3000

So, $l = 2500$, $f = 28$, $c.f. = 97$ and $h = 500$

$$\begin{aligned} \therefore \text{Median} &= l + \left(\frac{\frac{N}{2} - c.f.}{f} \right) \times h \\ &= 2500 + \frac{100 - 97}{28} \times 500 \\ &= 2500 + \frac{3}{28} \times 500 \\ &= 2500 + 53.57 \\ &= 2553.57 \end{aligned} \quad 2$$

SECTION — E

36. (i) Given ₹ x and ₹ y are the prize money per student for Hockey and Cricket, respectively.

$$\begin{aligned} \therefore 5x + 4y &= 9500 \quad \dots(i) \\ \text{and } 4x + 3y &= 7370 \quad \dots(ii) \end{aligned} \quad 1$$

- (ii) (a) On multiplying eq (i) by 4 and eq (ii) by 5, we get
- $$\begin{aligned} 20x + 16y &= 38000 \\ 20x + 15y &= 36850 \end{aligned}$$

$$\begin{array}{r} - \quad - \quad - \\ \hline y = 1150 \end{array}$$

On substituting value of y in equation (i), we get

$$\begin{aligned} 5x + 4(1150) &= 9500 \\ 5x + 4600 &= 9500 \\ 5x &= 4900 \\ x &= 980 \end{aligned}$$

Thus, prize money for Hockey is ₹ 980. 2

OR

- (b) From part (a),

Prize money for Hockey = ₹ 980

Prize money for Cricket = ₹ 1150

Difference between prize money = ₹ (1150 – 980)
= ₹ 170

Thus, prize money is ₹ 170 more for cricket in comparison to Hockey. 2

- (iii) Total prize money = 2 (Prize money for Hockey + Prize money for Cricket)
= 2(980 + 1150)
= 2 × 2130
= ₹ 4260 1

37. (i) Coordinates of $R = (200, 400)$
Coordinates of $S = (-200, 400)$ 1

- (ii) Since, side of square $PQRS = 400$
Thus, area of square $PQRS = (\text{side})^2$
= $(400)^2$
= 160000 unit² 2

OR

We know that, diagonal of square = $\sqrt{2} \times \text{side}$

$$\begin{aligned} \therefore \text{Diagonal PR of square } PQRS &= \sqrt{2} \times 400 \\ &= 400\sqrt{2} \text{ units} \end{aligned} \quad 2$$

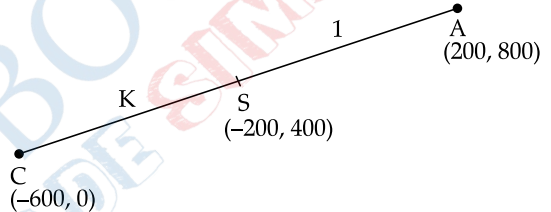
- (iii) 

Using section formula,

$$-200 = \frac{200K + 1(-600)}{K + 1}$$

$$-200K - 200 = 200K - 600$$

$$-400K = -400$$

$$K = 1 \quad 1$$

[Note: Here, S is the mid-point of CA, hence S divides CA in ratio 1 : 1]

38. (i) Radius of semi-circle (r) = $\frac{7}{2} = 3.5$ units

$$\begin{aligned} \text{Circumference of semi-circle} &= \pi r \\ &= \frac{22}{7} \times 3.5 \\ &= 11 \text{ units} \end{aligned}$$

\therefore Perimeter of parking area

$$\begin{aligned} &= \text{circumference of semi-circle} \\ &\quad + \text{diameter of semi-circle} \\ &= 11 + 7 \\ &= 18 \text{ units} \end{aligned} \quad 1$$

- (ii) (a) Area of parking = $\frac{\pi r^2}{2}$
= $\frac{22}{7} \times \frac{1}{2} \times (3.5)^2$
= $11 \times 0.5 \times 3.5$
= 19.25 unit²

Area of quadrants = 2 × area of one quadrant

$$= 2 \times \frac{\pi r_1^2}{4}$$

$$= 2 \times \frac{22}{7} \times \frac{1}{4} \times (2)^2$$

[$\because r_1 = 2$ units]

$$= 6.285 \text{ unit}^2$$

Thus, total area = 19.25 + 6.285

$$= 25.535 \text{ unit}^2 \quad 2$$

OR

(b) Area of playground = length \times breadth

$$= 14 \times 7$$

$$= 98 \text{ unit}^2$$

$$\text{Area of parking} = 19.25 \text{ unit}^2$$

[from part (ii) a]

$$\therefore \text{Ratio of playground : Ratio of parking area}$$

$$= 98 : 19.25$$

$$= \frac{9800}{1925}$$

$$= \frac{56}{11}$$

Thus, required ratio is 56 : 11. 2

(iii) We know that,

$$\text{Perimeter of parking area} = 18 \text{ units}$$

$$\text{Also, Perimeter of playground} = 2(l + b)$$

$$= 2(14 + 7)$$

$$= 2 \times 21$$

$$= 42 \text{ units}$$

Thus, total perimeter of parking area and playground

$$= 18 + 42 - 7$$

$$= 53 \text{ units}$$

Hence, total cost = ₹ 2 \times 53 = ₹ 106 1

Delhi Set-II

30/4/2

SECTION — A

1. Option (c) is correct

Explanation: $\because \sec^2 \theta = 1 + \tan^2 \theta$

$$\therefore \sec^2 \theta - \tan^2 \theta = 1$$

2. Option (a) is correct

Explanation: Since, $k + 2$, $4k - 6$ and $3k - 2$ are consecutive terms of A.P.

$$\therefore (4k - 6) - (k + 2) = (3k - 2) - (4k - 6)$$

$$3k - 8 = -k + 4$$

$$4k = 12$$

$$k = 3$$

11. Option (b) is correct

Explanation:

$$\text{Modal class : } 15 - 20 \quad (\because \text{Highest frequency} = 20)$$

Lower limit of modal class is 15.

Here, sum of frequencies, $N = 66$

$$\therefore \frac{N}{2} = \frac{66}{2} = 33$$

Class	Frequency	Cumulative frequency
0 - 5	10	10
5 - 10	15	25
10 - 15	12	37
15 - 20	20	57
20 - 25	9	66

33 lies in the class 10 - 15.

Therefore lower limit of median class is 10.

Sum of lower limits of median class and modal class

$$= 10 + 15 = 25$$

12. Option (a) is correct

Explanation: Here, $OQ = 9$ cm and $OP = 41$ cm

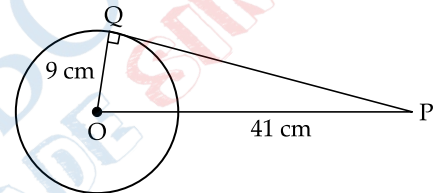
In ΔPQO ,

$$OP^2 = OQ^2 + PQ^2$$

$$(41)^2 = (9)^2 + PQ^2$$

$$1681 = 81 + PQ^2$$

$$PQ^2 = 1681 - 81$$

$$PQ^2 = 1600$$

$$PQ = 40 \text{ cm}$$

13. Option (c) is correct

Explanation:

Here,

$$\angle OPQ = 90^\circ$$

(angle between radius and tangent)

\therefore

$$\angle OPQ = 90^\circ - 50^\circ$$

$$= 40^\circ$$

Also, $\angle OPQ = \angle OQP = 40^\circ$ (being of equal radius)

In ΔPOQ ,

$$\angle OPQ + \angle OQP + \angle POQ = 180^\circ$$

$$40^\circ + 40^\circ + \angle POQ = 180^\circ$$

$$\angle POQ = 180^\circ - 80^\circ = 100^\circ$$

14. Option (b) is correct

Explanation: Total balls = 5 + n

$$\text{Probability of drawing red ball, } P(R) = \frac{5}{5+n}$$

$$\text{Probability of drawing green ball, } P(a) = \frac{n}{5+n}$$

Given,

$$P(G) = 3P(R)$$

$$\frac{n}{5+n} = 3 \times \frac{5}{5+n}$$

\therefore

or,

$$n = 15$$

SECTION — B

$$\begin{aligned}
 21. \text{ We have, } & \frac{5}{\cot^2 30^\circ} + \frac{1}{\sin^2 60^\circ} - \cot^2 45^\circ + 2 \sin^2 90^\circ \\
 & = \frac{5}{(\sqrt{3})^2} + \frac{1}{\left(\frac{\sqrt{3}}{2}\right)^2} - (1)^2 + 2(1)^2 \quad 1 \\
 & = \frac{5}{3} + \frac{4}{3} - 1 + 2 \\
 & = \frac{9}{3} + 1 \\
 & = 3 + 1 \\
 & = 4 \quad 1
 \end{aligned}$$

OR

$$\begin{aligned}
 \text{Given, } & \sin \theta = \cos \theta \\
 \therefore & \frac{\sin \theta}{\cos \theta} = 1 \\
 \Rightarrow & \tan \theta = 1 \\
 \Rightarrow & \tan \theta = \tan 45^\circ \\
 \Rightarrow & \theta = 45^\circ \quad 1 \\
 \text{Now, } & \tan^2 \theta + \cot^2 \theta - 2 \\
 & = \tan^2 45^\circ + \cot^2 45^\circ - 2 \\
 & = (1)^2 + (1)^2 - 2 \\
 & = 1 + 1 - 2 \\
 & = 0 \quad 1
 \end{aligned}$$

SECTION — C

$$\begin{aligned}
 29. \text{ (A) Given, } & S_{15} = 750 \text{ and first term } a = 15 \\
 \therefore & S_n = \frac{n}{2} [2a + (n-1)d] \quad 1 \\
 \therefore & S_{15} = \frac{n}{2} [2a + (15-1)d] \\
 750 = & \frac{15}{2} [2 \times 15 + 14d] \\
 50 \times 2 = & 30 + 14d \\
 14d = & 100 - 30 \\
 14d = & 70 \\
 d = & \frac{70}{14} = 5 \quad 1 \\
 \therefore & a_n = a + (n-1)d \\
 \therefore & a_{20} = a + (20-1)d \\
 & = 15 + 19 \times 5 \\
 & = 15 + 95 \\
 & = 110 \quad 1
 \end{aligned}$$

OR

$$\begin{aligned}
 \text{(B) First instalment, } & a = ₹ 1000 \\
 \text{common difference, } & d = ₹ 100 \\
 \therefore & a_n = a + (n-1)d \\
 \therefore & a_{30} = a + (30-1)d \\
 & = 1000 + 29 \times 100 \\
 & = 1000 + 2900 \\
 & = 3900
 \end{aligned}$$

Thus, ₹ 3900 will be paid by Rohan in the 30th instalment. 1

Amount of loan still paid by Rohan after 30 instalment = Total loan Amount – Amount paid in 30 instalments

$$\begin{aligned}
 & = 118000 - \frac{30}{2} [2 \times 1000 + (30-1) \times 100] \\
 & \quad \left[\because S_n = \frac{n}{2} [2a + (n-1)d] \right] \\
 & = 118000 - 15(2000 + 2900) \\
 & = 118000 - 15 \times 4900 \\
 & = 118000 - 73500 \\
 & = ₹ 44500 \quad 2
 \end{aligned}$$

30. Let $\sqrt{3}$ is a rational number.

$$\begin{aligned}
 \therefore & \sqrt{3} = \frac{p}{q} \\
 & [p \text{ and } q \text{ are co-primes integers and } q \neq 0] \\
 \Rightarrow & 3 = \frac{p^2}{q^2} \\
 \Rightarrow & p^2 = 3q^2 \quad \dots(i) \frac{1}{2} \\
 3 \text{ is factor of } & p^2 \quad \dots(ii) \frac{1}{2} \\
 \Rightarrow 3 \text{ is a factor of } & p \\
 \text{So, } & p = 3 \times m \quad [m \text{ is any integer}] \\
 \text{From eq (i),} & 9m^2 = 3q^2 \\
 \Rightarrow & q^2 = 3m^2 \quad \frac{1}{2} \\
 \therefore 3 \text{ is a factor of } & q^2 \\
 \Rightarrow 3 \text{ is a factor of } & q \quad \dots(iii) \frac{1}{2} \\
 \text{From eqs. (ii) and (iii),} & 3 \text{ is factor common factor of } p \text{ and } q. \quad \frac{1}{2} \\
 \text{It contradicts our assumption that } & p \text{ and } q \text{ are co-prime integers. Hence our assumption is wrong. } \frac{1}{2} \\
 \therefore \sqrt{3} \text{ is irrational.}
 \end{aligned}$$

SECTION — D

32. The remaining solid, after removing the conical cavity can be drawn as,
 Height of the cylinder, $h_1 = 20$ cm
 Radius of the cylinder, $r = \frac{12}{2} = 6$ cm
 Height of the cone, $h_2 = 8$ cm
 Radius of the cone, $r = 6$ cm

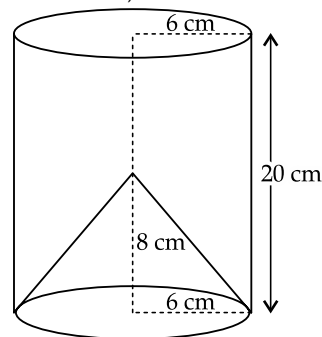

Total surface area of remaining solid
 = Areas of the top face of the cylinder
 + curved surface area of the cylinder
 + curved surface area of cone

Now, slant height of cone,

$$\begin{aligned} l &= \sqrt{r^2 + h_2^2} \\ &= \sqrt{6^2 + 8^2} \\ &= \sqrt{36 + 64} \\ &= \sqrt{100} \\ &= 10 \text{ cm} \end{aligned} \quad 1$$

$$\begin{aligned} \text{Curved surface area of the cone} &= \pi r l \\ &= \frac{22}{7} \times 6 \times 10 \\ &= \frac{1320}{7} \text{ cm}^2 \end{aligned} \quad 1$$

$$\begin{aligned} \text{Curved surface area of the cylinder} &= 2\pi r h_1 \\ &= 2 \times \frac{22}{7} \times 6 \times 20 \\ &= \frac{5280}{7} \text{ cm}^2 \end{aligned} \quad 1$$

$$\begin{aligned} \text{Area of the top face of the cylinder} &= \pi r^2 \\ &= \frac{22}{7} \times 6 \times 6 \\ &= \frac{792}{7} \text{ cm}^2 \end{aligned} \quad 1$$

$$\begin{aligned} \text{Thus, total surface area of remaining solid} &= \left(\frac{1320}{7} + \frac{5280}{7} + \frac{792}{7} \right) \text{ cm}^2 \\ &= \frac{7392}{7} \text{ cm}^2 \\ &= 1056 \text{ cm}^2 \end{aligned} \quad 1$$

35. (A)

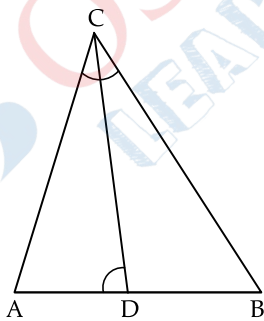

In $\triangle ACB$ and $\triangle ADC$,
 $\angle ADC = \angle BCA$ (given)
 $\angle A = \angle A$ (common)
 $\therefore \triangle ACB \sim \triangle ADC$ 1
 (By AA similarity criterion) Hence Proved

Since $\triangle ACB \sim \triangle ADC$
 $\frac{AC}{AD} = \frac{BC}{CD} = \frac{AB}{AC}$ 1
 $\frac{AC}{AD} = \frac{AB}{AC}$
 (on equating first and last term)

$$\begin{aligned} AC^2 &= AD \times AB \\ 8^2 &= 3 \times AB \\ \text{[Given } AC &= 8 \text{ cm and } AD = 3 \text{ cm]} \end{aligned}$$

$$\Rightarrow AB = \frac{64}{3} \text{ cm} \quad 1$$

Thus,

$$\begin{aligned} BD &= AB - AD \\ &= \frac{64}{3} - 3 \\ &= \frac{64 - 9}{3} \\ &= \frac{55}{3} = 18.3 \text{ cm} \end{aligned} \quad 2$$

OR

(B) Let $\triangle ABC$ in which a line DE parallel to BC intersects AB at D and AC at E .

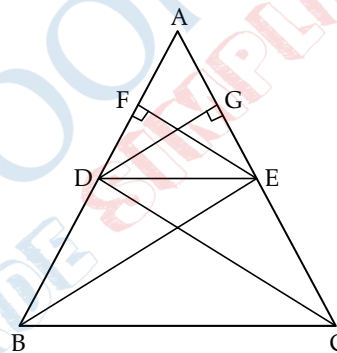

To prove: DE divides the two sides in the same ratio.

$$\frac{AD}{DB} = \frac{AE}{EC} \quad 1$$

Construction: Join BE and CD .
 Draw $EF \perp AB$ and $DG \perp AC$

Proof: we know that,

$$\text{Area of triangle} = \frac{1}{2} \times \text{base} \times \text{height}$$

Then

$$\begin{aligned} \frac{\text{area}(\triangle ADE)}{\text{area}(\triangle BDE)} &= \frac{\frac{1}{2} \times AD \times EF}{\frac{1}{2} \times DB \times EF} \\ &= \frac{AD}{DB} \end{aligned} \quad \dots(i) \quad 1$$

and

$$\begin{aligned} \frac{\text{area}(\triangle ADE)}{\text{area}(\triangle DEC)} &= \frac{\frac{1}{2} \times AE \times DG}{\frac{1}{2} \times EC \times DG} \\ &= \frac{AE}{EC} \end{aligned} \quad \dots(ii) \quad 1$$

Since, $\triangle BDE$ and $\triangle DEC$ lie between the same parallel DE and BC , and are on the same base DE .

We have, $\text{area}(\triangle BDE) = \text{area}(\triangle DEC)$... (iii) 1

From eqs. (i), (ii) and (iii), we get

$$\frac{AD}{DB} = \frac{AE}{EC} \quad \text{Hence Proved } 1$$

SECTION — A**7. Option (d) is correct**

Explanation: Given A.P.: $\sqrt{7}, \sqrt{28}, \sqrt{63}, \dots$

or $\sqrt{7}, 2\sqrt{7}, 3\sqrt{7}, \dots$

Here, $a = \sqrt{7}$, $d = \sqrt{7}$

$$\begin{aligned} \therefore a_4 &= a + (4-1)d \\ &= \sqrt{7} + 3\sqrt{7} \\ &= 4\sqrt{7} \\ &= \sqrt{112} \end{aligned}$$

8. Option (b) is correct

Explanation: $(\sec^2 \theta - 1)(\operatorname{cosec}^2 \theta - 1)$
 $= (\tan^2 \theta)(\cot^2 \theta)$
 $[\because \sec^2 \theta - \tan^2 \theta = 1 \text{ and } \operatorname{cosec}^2 \theta - \cot^2 \theta = 1]$
 $= \tan^2 \theta \times \frac{1}{\tan^2 \theta}$
 $= 1$

15. Option (c) is correct

Explanation:

Marks	No. of students	f_i
0 – 10	$3 - 0 = 3$	3
10 – 20	$12 - 3 = 9$	9
20 – 30	$27 - 12 = 15$	15
30 – 40	$57 - 27 = 30$	30
40 – 50	$75 - 57 = 18$	18
50 – 60	$80 - 75 = 5$	5

Modal class has maximum frequency (30) in class 30 – 40.

16. Option (d) is correct

Explanation:

Here $\angle OTP = 90^\circ$
 (angle between radius and tangent)

In ΔPTO ,

$$\angle TPO + \angle PTO + \angle TOP = 180^\circ$$

$$25^\circ + 90^\circ + \angle TOP = 180^\circ$$

$$\angle TOP = 180^\circ - 115^\circ$$

$$= 65^\circ \quad (\text{Linear pair})$$

Now, $\angle TOP + x = 180^\circ$

$$65^\circ + x = 180^\circ$$

$$x = 180^\circ - 65^\circ$$

$$= 115^\circ$$

17. Option (a) is correct

Explanation: As $PQ \parallel AC$ by using basic proportionality theorem,

$$\frac{BP}{PA} = \frac{BQ}{QC}$$

$$\frac{4}{2.4} = \frac{5}{QC}$$

$$QC = \frac{5 \times 2.4}{4}$$

$$QC = 3 \text{ cm}$$

18. Option (b) is correct

Explanation: Let the points $A(-4, 0)$, $B(4, 0)$ and $C(0, 3)$ are vertices

$$\begin{aligned} \therefore AB &= \sqrt{(4 - (-4))^2 + (0 - 0)^2} \\ &= \sqrt{(8)^2} = 8 \end{aligned}$$

$$\begin{aligned} BC &= \sqrt{(0 - 4)^2 + (3 - 0)^2} \\ &= \sqrt{16 + 9} \\ &= \sqrt{25} = 5 \end{aligned}$$

$$\begin{aligned} CA &= \sqrt{(-4 - 0)^2 + (0 - 3)^2} \\ &= \sqrt{16 + 9} \\ &= \sqrt{25} = 5 \end{aligned}$$

Since, $BC = CA$, hence triangle is isosceles.

SECTION — B**22. (A) we have,**

$$\begin{aligned} &2 \sec^2 \theta + 3 \operatorname{cosec}^2 \theta - 2 \sin \theta \cos \theta \\ &= 2 \sec^2 45^\circ + 3 \operatorname{cosec}^2 45^\circ - 2 \sin 45^\circ \cos 45^\circ \end{aligned}$$

(given $\theta = 45^\circ$)

$$= 2(\sqrt{2})^2 + 3(\sqrt{2})^2 - 2 \frac{1}{\sqrt{2}} \times \frac{1}{\sqrt{2}}$$

1

$$= 2 \times 2 + 3 \times 2 - \frac{2}{2}$$

$$= 4 + 6 - 1$$

$$= 9$$

1

OR

(B) Given $\sin \theta - \cos \theta = 0$

$$\therefore \frac{\sin \theta}{\cos \theta} = 1$$

or $\tan \theta = 1$

or $\theta = \frac{\pi}{4}$

1

Now, $\sin^4 \theta + \cos^4 \theta$

$$= \left(\sin \frac{\pi}{4} \right)^4 + \left(\cos \frac{\pi}{4} \right)^4$$

$$= \left(\frac{1}{\sqrt{2}} \right)^4 + \left(\frac{1}{\sqrt{2}} \right)^4$$

$$= \frac{1}{4} + \frac{1}{4}$$

$$= \frac{2}{4} = \frac{1}{2}$$

1

SECTION — C

26. Given quadratic equation is:

$$px^2 - 14x + 8 = 0 \quad \dots(i)$$

Let α and β be the roots of equation.

ACQ, $\beta = 6\alpha \quad \dots(ii) \frac{1}{2}$

Now, Sum of roots, $(\alpha + \beta) = \frac{-(-14)}{p}$

$\therefore \alpha + \beta = \frac{14}{p} \quad \dots(iii) \frac{1}{2}$

Product of roots, $(\alpha\beta) = \frac{8}{p}$

$\therefore \alpha\beta = \frac{8}{p} \quad \dots(iv) \frac{1}{2}$

From eqs. (ii) and (iii), we get

$$\alpha + 6\alpha = \frac{14}{p}$$

$$7\alpha = \frac{14}{p}$$

$$\alpha = \frac{2}{p} \quad \frac{1}{2}$$

Substituting value of α in eq. (iv), we get

$$\frac{2}{p} \cdot \beta = \frac{8}{p}$$

$$\frac{2}{p} \cdot 6\alpha = \frac{8}{p} \quad [\text{from eq. (i)}]$$

$$\frac{12}{p} \cdot \frac{2}{p} = \frac{8}{p} \quad \left(\alpha = \frac{2}{p} \right)$$

$$\frac{24}{p^2} = \frac{8}{p}$$

$$p = \frac{24}{8}$$

$$p = 3 \quad 1$$

27. **Given:** ME and NE are the tangents drawn from a point P to a circle with centre O.

Also, the line segment OM and ON are drawn.

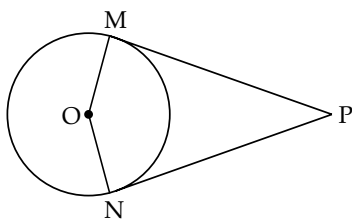

1

To prove: $\angle MEO = \angle NEO$

Construction: Join OE

Proof: In $\triangle OME$ and $\triangle ONE$

$OM = ON$ (radii)

$OE = OE$ (common)

$ME = NE$

(tangents from external points to a circle are equal in length)

$\therefore \triangle OME \cong \triangle ONE$

(By SSS criterion)

So, $\angle MEO = \angle NEO$

Hence OE bisects $\angle MEN$.

Hence Proved 2

SECTION — D

32. **(A) Given:** In $\triangle PQR$, N is a point on PR such that $QN \perp PR$

and

$$PN \cdot NR = QN^2$$

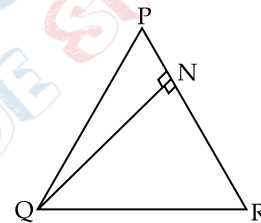

To prove: $\angle PQR = 90^\circ$

Proof: $PN \cdot NR = QN \cdot QN$

or $\frac{PN}{QN} = \frac{QN}{NR} \quad \dots(i) 1$

In $\triangle QNP$ and $\triangle RNQ$,

$$\frac{PN}{QN} = \frac{QN}{NR}$$

and $\angle PNQ = \angle RNQ$ (each 90°)

$\therefore \triangle QNP \sim \triangle RNQ$

(By SAS similarity criterion) 1

Then, $\triangle QNP$ and $\triangle RNQ$ are equiangular.

i.e., $\angle PQN = \angle QRN$

and $\angle RQN = \angle QPN$

On adding both sides, we get

$$\angle PQN + \angle RQN = \angle QRN + \angle QPN$$

$$\Rightarrow \angle PQR = \angle QRN + \angle QPN \quad \dots(ii) 1$$

We know that, sum of angles of a triangle = 180°

In $\triangle PQR$,

$$\angle PQR + \angle QPR + \angle QRP = 180^\circ$$

$$\begin{aligned} \Rightarrow \angle PQR + \angle QPN + \angle QRN &= 180^\circ \\ [\because \angle QPR &= \angle QPN \text{ and } \angle QRP = \angle QRN] \\ \Rightarrow \angle PQR + \angle PQR &= 180^\circ \\ \Rightarrow 2\angle PQR &= 180^\circ \\ \Rightarrow \angle PQR &= \frac{180^\circ}{2} = 90^\circ \\ \therefore \angle PQR &= 90^\circ \text{ Hence Proved 2} \end{aligned}$$

OR

- (B) **Given:** Two triangles $\triangle ABC$ and $\triangle DBC$ which stand on the same base but on opposite sides of BC .

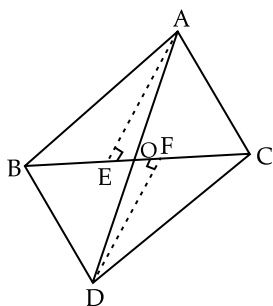

To prove: $\frac{\text{ar}(\triangle ABC)}{\text{ar}(\triangle DBC)} = \frac{AO}{DO}$

Construction: Draw $AE \perp BC$ and $DF \perp BC$. 1

Proof: In $\triangle AOE$ and $\triangle DOF$

$$\angle AEO = \angle DOF = 90^\circ$$

(By construction)

$$\angle AOE = \angle DOF$$

(Vertically opposite angles)

$$\begin{aligned} \therefore \triangle AOE &\sim \triangle DOF \\ (\text{By AA criterion of similarity}) &2 \end{aligned}$$

Thus, $\frac{AE}{DF} = \frac{AO}{DO}$... (i)

$$\text{Now, } \frac{\text{ar}(\triangle ABC)}{\text{ar}(\triangle DBC)} = \frac{\frac{1}{2} \times BC \times AE}{\frac{1}{2} \times BC \times DF}$$

$$\text{or } \frac{\text{ar}(\triangle ABC)}{\text{ar}(\triangle DBC)} = \frac{AE}{DF} \quad \dots \text{(ii) 1}$$

From eqs. (i) and (ii) we get

$$\frac{\text{ar}(\triangle ABC)}{\text{ar}(\triangle DBC)} = \frac{AO}{DO} \quad \text{Hence Proved 1}$$

33. **Given,** Radius of cylinder = 3.5 cm
 Height of cylinder = 10 cm
Total surface area of article
 = Curved surface area of cylinder
 + Curved surface area of two hemisphere 1

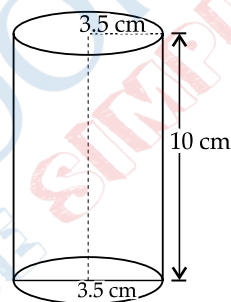

Now, curved surface area of cylinder

$$= 2\pi rh$$

$$= 2 \times \pi \times 3.5 \times 10$$

$$= 70\pi$$

1

Surface area of a hemisphere

$$= 2\pi r^2$$

$$= 24.5\pi$$

1

Hence, Total surface area of article

$$= 70\pi + 2(24.5\pi)$$

$$= 70\pi + 49\pi$$

$$= 119\pi$$

$$= 119 \times \frac{22}{7}$$

$$= 374 \text{ cm}^2$$

2

Outside Delhi Set-I

30/6/1

SECTION — A

1. Option (c) is correct

Explanation: $p^2 = \frac{32}{50}$

$$p^2 = \frac{16}{25}$$

$$\Rightarrow p = \sqrt{\frac{16}{25}} = \frac{4}{5}$$

Since p is in form of $\frac{p}{q}$ where $q \neq 0$.

$\therefore p$ is a rational number.

2. Option (c) is correct

Explanation: Refer the following Figure.

x -coordinate = -6

So, Distance of point along x -axis from origin = -6 units.

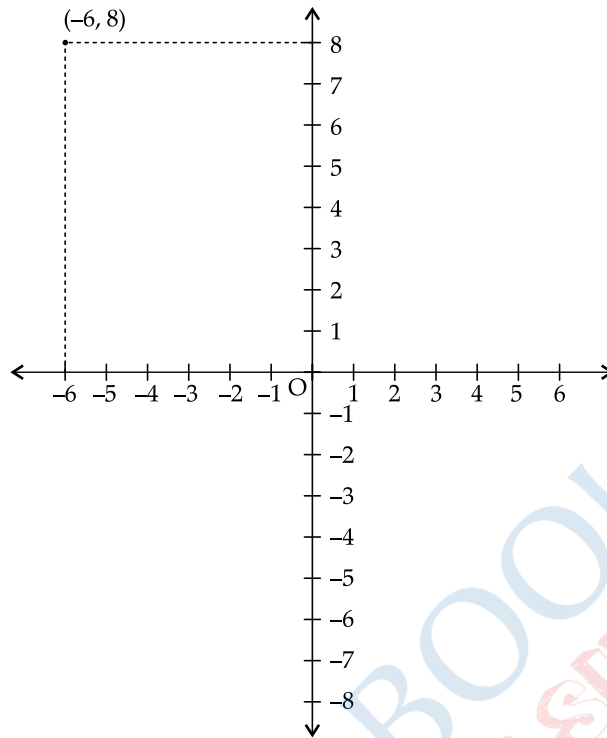

y -coordinate = 8

So, Distance of point along y -axis from origin = 8 units.

\therefore The perpendicular distance of point $(-6, 8)$ from x -axis is 8 units.

3. Option (d) is correct

Explanation: Let the zeroes of polynomial be $\alpha = -5$ and $\beta = -3$

The general form of polynomial with α and β as the zeroes is given by

$$k[x^2 - (\alpha + \beta)x + \alpha\beta]$$

where k is any real number

$$k[x^2 - (-8)x + (-15)]$$

$$(\because \alpha + \beta = (-5) + (-3) = -8 \text{ \& } \alpha\beta = -5 \times -3 = 15)$$

$$\Rightarrow k(x^2 + 8x + 15)$$

Here k can have any value

Hence, more than 3 polynomials can have the zeroes -5 and -3 .

4. Option (a) is correct

Explanation: $3x - y = 3$ (Given)

At the y -axis, value of $x = 0$

Substitute value of ' x ' in given equations we have,

$$3 \times 0 - y = 3$$

$$-y = 3$$

$$y = -3$$

Hence, the line $3x - y = 3$ cuts y axis at point $(0, -3)$.

5. Option (d) is correct

Explanation: Circumference of circle = $2\pi r$

$$\frac{2\pi r_1}{2\pi r_2} = \frac{4}{5}$$

\therefore

$$\Rightarrow \frac{r_1}{r_2} = \frac{4}{5}$$

Hence, Ratio of their radii = 4 : 5.

6. Option (d) is correct

Explanation: $(x^2 - 1)$

$$(x + 1)(x - 1)$$

$$x + 1 = 0 \text{ \& } x - 1 = 0$$

$$x = -1, x = 1$$

Thus,

$$\alpha = -1 \text{ \& } \beta = 1$$

$$\therefore \alpha + \beta = -1 + 1 = 0.$$

7. Option (d) is correct

Explanation: $\frac{\cos^2 \theta}{\sin^2 \theta} - \frac{1}{\sin^2 \theta}$

$$\frac{\cos^2 \theta - 1}{\sin^2 \theta}$$

...(i)

We know that,

$$\sin^2 \theta + \cos^2 \theta = 1$$

$$\therefore \cos^2 \theta - 1 = -\sin^2 \theta$$

Substitute value of $\cos^2 \theta - 1$ in equation (i)

$$\frac{-\sin^2 \theta}{\sin^2 \theta} = -1$$

8. Option (b) is correct

Explanation: $\Delta PQR \sim \Delta ABC$

$$PQ = 6 \text{ cm, } AB = 8 \text{ cm}$$

Perimeter of $\Delta ABC = 36 \text{ cm}$

We know that,

Ratio of perimeter of two similar triangles is same as the ratio of their corresponding sides.

$$\begin{aligned} \therefore \frac{\text{Perimeter of } \triangle ABC}{\text{Perimeter of } \triangle PQR} &= \frac{8}{6} \\ \Rightarrow \frac{36}{x} &= \frac{8}{6} \\ \Rightarrow x &= \frac{36 \times 6}{8} \\ x &= 27 \end{aligned}$$

Thus, Perimeter of $\triangle PQR = 27$ cm.

9. Option (d) is correct

Explanation: For equation having real and equal roots

$$\begin{aligned} D &= b^2 - 4ac = 0 \\ \Rightarrow b^2 - 4ac &= 0 \\ \Rightarrow b^2 &= 4ac \\ \frac{b^2}{4a} &= c \end{aligned}$$

10. Option (b) is correct

Explanation: In $\triangle ABC$

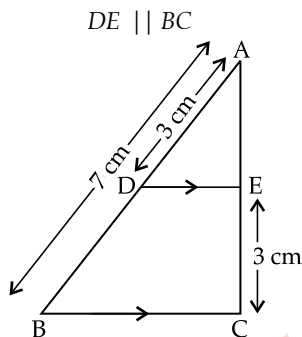

Then, $\frac{AD}{DB} = \frac{AE}{EC}$

(By Basic Proportionality theorem)

$$\begin{aligned} \Rightarrow \frac{3}{4} &= \frac{AE}{3} \\ (\because DB &= AB - AD = 7 - 3 = 4 \text{ cm}) \\ \therefore AE &= \frac{9}{4} = 2.25 \text{ cm.} \end{aligned}$$

11. Option (c) is correct

Explanation: Number of balls which is neither a blue nor a Pink = 7

$$\begin{aligned} \therefore P(\text{Getting a ball which is neither blue or pink}) &= \frac{7}{20} \end{aligned}$$

12. Option (d) is correct

Explanation: Volume of cone = $\frac{1}{3}\pi r^2 h$

$$\begin{aligned} &= \frac{1}{3} \times 156 \times 8 \quad (\because \text{Area of base} = \pi r^2 = 156 \text{ cm}^2) \\ &= 416 \text{ cm}^3 \end{aligned}$$

13. Option (c) is correct

Explanation: cost t of one chair = x

cost of one table = y

$$\begin{aligned} \therefore 3x + y &= ₹ 900 \\ 5x + 3y &= ₹ 2100 \end{aligned}$$

14. Option (a) is correct

Explanation: $\angle PAC = 90^\circ$ (Tangent is perpendicular to the radius through point of contact)

$$\angle PBA = 90^\circ$$

(Given)

$$\angle APB = 55^\circ$$

$$\text{So, } \angle APB + \angle PAC + \angle PBA + \angle ACB = 360^\circ$$

(Sum of all angles of quadrilaterals is 360°)

$$\angle ACB = 360^\circ - 235^\circ$$

$$= 125^\circ$$

$$\angle ACB = 2\angle AQB$$

$$\therefore \angle AQB = \frac{125^\circ}{2} = 62\frac{1}{2}$$

(\because Angle subtended by an arc at centre is double the angle subtended by it at any other point of contact.)

15. Option (b) is correct

Explanation: Total Number of Cards = 52

Total Number of Face Cards = 12

$\therefore P(\text{Probability of getting a Face card})$

$$= \frac{12}{52}$$

$$= \frac{3}{13}$$

16. Option (d) is correct

Explanation: For the given acute angle (θ),

$$\tan^2 \theta + 1 = \sec^2 \theta$$

So, $\sec^2 \theta - \tan^2 \theta = 1$ but in option (d) is incorrect

Hence, option (d) is false.

17. Option (d) is correct

Explanation: Zeroes of Quadratic Polynomial

$$x^2 + (a + 1)x + b \quad \dots(i)$$

are 2 and -3

$$\therefore \alpha = 2 \text{ and } \beta = -3$$

Then, Sum of zeroes ($\alpha + \beta$) = $(2 + (-3))$

$$= -1$$

Product of zeroes ($\alpha\beta$) = 2×-3

$$= -6$$

\therefore Quadratic Polynomial

$$\Rightarrow x^2 - (\alpha + \beta)x + \alpha\beta = 0$$

$$\Rightarrow x^2 + 1x - 6 = 0 \quad \dots(ii)$$

From Equation (i) and (ii)

$$a + 1 = 1$$

$$a = 0$$

and

$$b = -6$$

18. Option (d) is correct

Explanation: $S_n = 3n^2 + n$

$$d = 6$$

According to Formula,

$$S_n = \frac{n}{2}[2a + (n-1)d]$$

$$3n^2 + n = \frac{n}{2}[2a + 6n - 6]$$

$$6n^2 + 2n = 2an + 6n^2 - 6n$$

$$\frac{8n}{2n} = a$$

$$\therefore a = 4$$

Thus, first term = 4.

19. Option (a) is correct

Explanation: In Quadratic Equation with rational coefficient, irrational roots occur in conjugate pairs.

$$\therefore \text{If one root} = 5 + \sqrt{7}$$

$$\text{then second root} = 5 - \sqrt{7}$$

Hence, Assertion is True and Reason is also true and correct explanation.

20. Option (a) is correct

Explanation: Let, $\operatorname{cosec} \theta - \cot \theta = \frac{1}{2}$

Then, According to Trigonometry Identity

$$\operatorname{cosec}^2 \theta - \cot^2 \theta = 1$$

$$\therefore \operatorname{cosec} \theta - \cot \theta = \frac{\operatorname{cosec}^2 \theta - \cot^2 \theta}{2}$$

$$\Rightarrow \frac{1}{2} = \frac{(\operatorname{cosec} \theta + \cot \theta)(\operatorname{cosec} \theta - \cot \theta)}{2}$$

$$\Rightarrow \frac{1}{2} = \frac{\operatorname{cosec} \theta + \cot \theta}{2} \times \frac{1}{2}$$

$$\Rightarrow 2 = \operatorname{cosec} \theta + \cot \theta$$

$$2 = \operatorname{cosec} \theta + \cot \theta \quad \text{Hence Proved.}$$

\therefore Assertion is True.

Reason : It is a Trigonometric Identity which is used in Assertion

\therefore Reason is also true and correct. Explanation of Assertion.

SECTION — B

21. (A) If 6^n ends with 0 then it must have 5 as a factor.

But, $6^n = (2 \times 3)^n$
 $= 2^n \times 3^n$

This shows that 2 and 3 are the only Prime Factors of 6^n .

According to Fundamental theorem of arithmetic prime factorization of each number is Unique.

So, 5 is not a factor of 6^n

Hence, 6^n can never end with the digit 0. 1

OR

(B) By Prime Factorisation, we get

2	72
2	36
2	18
3	9
3	3
1	

2	120
2	60
2	30
3	15
5	5
1	

$$\text{Factors of } 72 = 2^3 \times 3^2$$

$$120 = 2^3 \times 3^1 \times 5^1$$

HCF (72, 120) = Product of common terms with lowest power

$$= 2^3 \times 3^1$$

$$= 8 \times 3 = 24$$

LCM (72, 120) = Product of Prime Factors with highest power.

$$= 2^3 \times 3^2 \times 5$$

$$= 8 \times 9 \times 5 = 360 \quad \mathbf{1}$$

Thus, HCF and LCM of 72 and 120 are 24 and 360 respectively.

22.

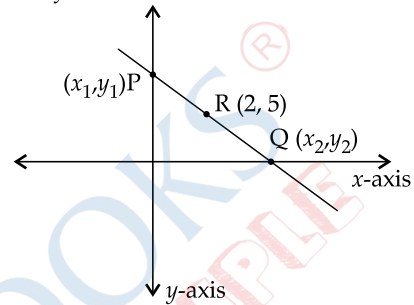

According to figure, P is on y-axis 1

\therefore Coordinates of P are $(0, y_1)$

Q is on x-axis

\therefore Co-ordinates of Q are $(x_2, 0)$

According to mid-point Formula

$$2 = \frac{0 + x_2}{2} \quad \text{and} \quad 5 = \frac{y_1 + 0}{2}$$

$$4 = x_2; \quad 10 = y_1$$

Thus coordinates of P are $(0, 10)$

And, coordinates of Q are $(4, 0)$. 1

23.

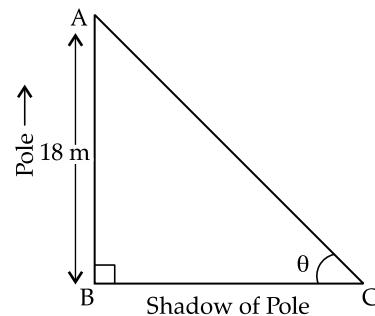

In right $\triangle ABC$ 1

$$\tan \theta = \frac{AB}{BC} = \frac{P}{B} \quad \dots(i)$$

But $\tan \theta = \frac{6}{7}$ (Given)

Substitute value of $\tan \theta$ and height of pole $AB = 18$ m is equation (i)

$$\Rightarrow \frac{6}{7} = \frac{18}{BC}$$

$$\Rightarrow BC = \frac{18 \times 7}{6} = 21 \text{ m}$$

Hence, the length of the shadow = 21 m. 1

24.

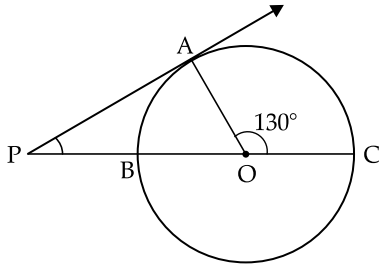

We know that the tangent at a point to a circle is perpendicular to the radius passing through the point of contact.

$\therefore \angle OAP = 90^\circ$
 Now, $\angle AOC + \angle AOB = 180^\circ$ (Linear pair)
 $\therefore \angle AOP = 50^\circ$ **1**

In $\triangle PAO$
 $\angle APO + \angle PAO + \angle AOP = 180^\circ$
 (Sum of all angles of a triangle is 180°)

$\Rightarrow \angle APO = 180^\circ - (\angle PAO + \angle AOP)$
 $= 180^\circ - (90^\circ + 50^\circ)$
 $= 40^\circ$ **1**

25. (A) In $\triangle ABC$

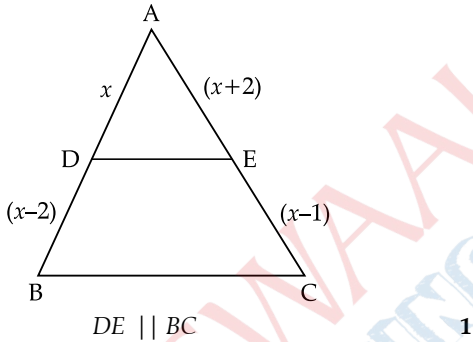

$DE \parallel BC$ **1**
 According to Basic Proportionality theorem.

$\frac{AD}{DB} = \frac{AE}{EC}$
 $\Rightarrow \frac{x}{x-2} = \frac{x+2}{x-1}$
 $x(x-1) = (x-2)(x+2)$
 $x^2 - x = x^2 - 4$
 $(\because (a-b)(a+b) = a^2 - b^2)$
 $-x = -4$ **1**
 $\therefore x = 4$

OR

(B) Given: ABCD is a trapezium, $AB \parallel DC$.

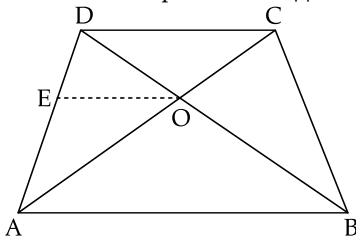

Diagonals AC and BD intersect at O.

To Prove: $\frac{OA}{OC} = \frac{OB}{OD}$

Construction: Draw $OE \parallel AB$, through O, meeting AD at E.

Proof: In $\triangle ADC$
 $EO \parallel DC$ ($\because EO \parallel AB \parallel DC$)
 $\therefore \frac{AE}{ED} = \frac{OA}{OC}$ (By Thales Theorem (i))

In $\triangle DAB$, $EO \parallel AB$ (By constructions) **1**
 $\therefore \frac{AE}{ED} = \frac{OB}{OD}$ (By Thales Theorem)

...(ii)

From (i) and (ii) **1**
 $\frac{OA}{OC} = \frac{OB}{OD}$ **Hence Proved.**

SECTION — C

26.

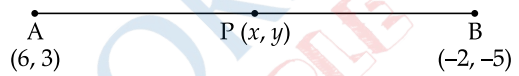

According to 'Section Formula'
 If point (x, y) divides the line joining the point (x_1, y_1) and (x_2, y_2) in the ratio $m : n$ then,

$(x, y) = \left(\frac{mx_2 + nx_1}{m+n}, \frac{my_2 + ny_1}{m+n} \right)$ **1**

Let ratio = $m : n$
 Here $x_1 = 6, y_1 = 3, x_2 = -2, y_2 = -5$ **1**
 And $y = 0$ (\because Point lies on x-axis)

$\Rightarrow \frac{my_2 + ny_1}{m+n} = 0$
 $\frac{-5m + 3n}{m+n} = 0$
 $-5m + 3n = 0$
 $-5m = -3n$
 $\frac{m}{n} = \frac{3}{5}$ **1**

Thus ratio, $m : n = 3 : 5$.

27. (A) By Prime Factorization

2	26	5	65	3	117
13	13	13	13	3	39
	1		1	13	13
					1

Factors of 26 = 2×13 **1**
 Factors of 65 = 5×13
 Factors of 117 = $3^2 \times 13$
 HCF of (26, 65, 117) = Product of common terms with lowest power.
 $= 13$ **1**

LCM of (26, 65, 117) = Product of Prime Factors with highest Power.
 $= 2 \times 5 \times 3^2 \times 13$
 $= 1170$ **1**

OR

(B) Let $\sqrt{2}$ be rational

Then, its simplest form = $\frac{p}{q}$

Where p and q are integers having no common factor other than 1, and $q \neq 0$.

Now, $\sqrt{2} = \frac{p}{q}$

On squaring both sides we get

$$2 = \frac{p^2}{q^2}$$

$$2q^2 = p^2 \quad \dots(i)$$

$\Rightarrow 2$ divides p^2 ($\because 2$ divides $2q^2$) 1

$\Rightarrow 2$ divides p ($\because 2$ is a prime and divides $p^2 \Rightarrow 2$ divides p)

Let $p = 2r$ for some integer r

Putting $p = 2r$ in (i) we get

$$2q^2 = 4r^2$$

$\Rightarrow q^2 = 2r^2$ 1

$\Rightarrow 2$ divides q^2 ($\because 2$ divides $2r^2$)

$\Rightarrow 2$ divides q ($\because 2$ is prime and divides $q^2 \Rightarrow 2$ divides q)

Thus, 2 is a common factor of p and q .

But this contradicts the fact that p and q have no common factor other than 1.

Thus, contradiction arises by assuming $\sqrt{2}$ is rational.

Hence, $\sqrt{2}$ is irrational. 1

28.

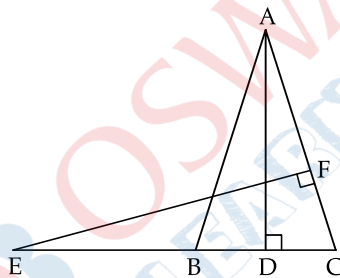

Given: $AB = AC$
 $\therefore \angle B = \angle C$... (i)

$AD \perp BC$
 $\therefore \angle ADB = 90^\circ$... (ii)

$EF \perp AC$
 $\therefore \angle EFC = 90^\circ$... (iii) 1

In $\triangle ABD$ and $\triangle ECF$,
 $\angle B = \angle C$ (From (i))

$\angle ADB = \angle EFC = 90^\circ$ (From (ii) & (iii))
 $\therefore \triangle ABD \sim \triangle ECF$ (By AA Criterion) 2

29. (A) Let First Number = x

Other Number = $15 - x$

So, $\frac{1}{x} + \frac{1}{15-x} = \frac{3}{10}$

$$\frac{15-x+x}{x(15-x)} = \frac{3}{10}$$

$$15 \times 10 = 3x(15-x) \quad 1$$

$$150 = 45x - 3x^2 \quad 1$$

$$3x^2 - 45x + 150 = 0$$

$$x^2 - 15x + 50 = 0$$

$$x^2 - 10x - 5x + 50 = 0$$

$$x(x-10) - 5(x-10) = 0$$

$$(x-10)(x-5) = 0$$

$$x = 10, x = 5 \quad 1$$

If First Number (x) = 10

Other Number ($15 - x$) = 5

If First Number (x) = 5

Other Number ($15 - x$) = 10

OR

(B) For Given Quadratic Equation

$$x^2 - 7x + 10 = 0$$

$$x^2 - 5x - 2x + 10 = 0$$

$$x(x-5) - 2(x-5) = 0$$

$$(x-5)(x-2) = 0$$

$$x = 5 \text{ and } x = 2$$

$\therefore \alpha = 5 \text{ and } \beta = 2$

Thus $\alpha^2 = 25 \text{ and } \beta^2 = 4$ 1

Quadratic Equation whose roots are α^2 and β^2

$$\Rightarrow x^2 - (\alpha^2 + \beta^2)x + \alpha^2\beta^2 = 0$$

$$x^2 - (25 + 4)x + 25 \times 4 = 0$$

$$x^2 - 29x + 100 = 0 \quad 2$$

30. $\frac{1 + \sec A}{\sec A} = \frac{\sin^2 A}{1 - \cos A}$

$$\text{LHS} = \frac{1 + \sec A}{\sec A} = \frac{1 + \frac{1}{\cos A}}{\frac{1}{\cos A}}$$

$$\Rightarrow \frac{\cos A + 1}{\cos A} \times \frac{\cos A}{1} = \cos A + 1 \quad \dots(i) \quad 1$$

$$\text{RHS} = \frac{\sin^2 A}{1 - \cos A} = \frac{1 - \cos^2 A}{1 - \cos A}$$

$$\frac{(1 + \cos A)(1 - \cos A)}{1 - \cos A} = 1 + \cos A \quad \dots(ii)$$

From (i) and (ii),

LHS = RHS Hence Proved. 2

31. Given

$$\theta = 60^\circ$$

$$R = 21 \text{ cm}$$

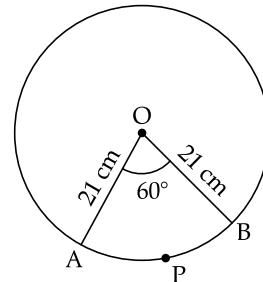

(i) Area of sector APB = $\frac{\theta}{360^\circ} \pi r^2$ 1½

$$= \frac{60^\circ}{360^\circ} \times \frac{22}{7} \times 21 \times 21$$

$$= \frac{1}{6} \times 22 \times 3 \times 21$$

$$= 11 \times 21$$

$$= 231 \text{ cm}^2$$

$$\begin{aligned}
 \text{(ii) Length of the arc } APB &= \frac{\theta}{360^\circ} \times 2\pi r && 1\frac{1}{2} \\
 &= \frac{60}{360^\circ} \times 2 \times \frac{22}{7} \times 21 \\
 &= \frac{1}{6} \times 2 \times 22 \times 3 \\
 &= 22 \text{ cm}
 \end{aligned}$$

SECTION — D

32. (A) Given: $TP = TQ$ (Two tangents from external point T are equal)

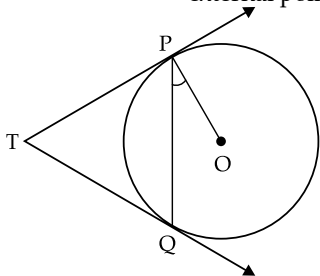

To Prove: $\angle PTQ = 2\angle OPQ$

Proof: Let $\angle PTQ = x$

$$TP = TQ$$

$\therefore \angle TPQ = \angle TQP$

In $\triangle TPQ$,

$$\angle TPQ + \angle TQP + \angle PTQ = 180^\circ$$

$$2\angle TPQ + x = 180^\circ$$

$$\angle TPQ = \frac{180^\circ - x}{2}$$

$$\angle TPQ = 90^\circ - \frac{x}{2} \quad \dots(i)$$

OP is radius

$$\therefore \angle OPT = 90^\circ \quad 2$$

(Tangent at any point of a circle is perpendicular to the radius through point of contact.)

$$\Rightarrow \angle OPQ + \angle QPT = 90^\circ$$

$$\angle OPQ = 90^\circ - \angle QPT \quad 1$$

$$\angle OPQ = 90^\circ - \left(90^\circ - \frac{x}{2}\right) \quad \text{(From (i))}$$

$$\angle OPQ = 90^\circ - 90^\circ + \frac{x}{2}$$

$$2\angle OPQ = x$$

$$\therefore \angle PTQ = 2\angle OPQ \quad (\because \angle PTQ = x)$$

Hence Proved. 2

OR

- (B) Lengths of tangents drawn from an external point to a circle are equal.

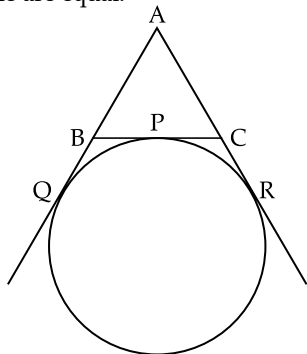

$$\begin{aligned}
 \therefore AQ &= AR \quad \dots(i) \text{ (Tangents from A)} \\
 BP &= BQ \quad \dots(ii) \text{ (Tangents from B)} \\
 CP &= CR \quad \dots(iii) \text{ (Tangents from C)}
 \end{aligned}$$

$$\text{Perimeter of } \triangle ABC \\ AB + BC + AC$$

$$= AB + BP + PC + AC$$

$$= AB + BQ + CR + AC$$

[Using (ii) and (iii)]

$$= AQ + AR$$

$$= 2AQ$$

[From (i)]

$$\therefore AQ = \frac{1}{2} \times \text{Perimeter of } \triangle ABC. \quad 2$$

33.

$$\text{Radius} = 7 \text{ cm}$$

$$\text{Height} = 2 \times \text{Radius} = 14 \text{ cm}$$

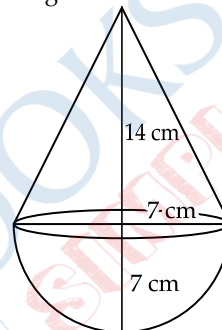

$$\text{Volume of cone} = \frac{1}{3} \pi r^2 h \quad 1$$

$$\text{Volume of hemisphere} = \frac{2}{3} \pi r^3 \quad 1$$

$$\text{Volume of solid} = \text{Volume of cone} + \text{Volume of hemisphere} \quad 1$$

$$= \frac{1}{3} \pi r^2 h + \frac{2}{3} \pi r^3$$

$$= \frac{1}{3} \pi r^2 (h + 2r)$$

$$= \frac{1}{3} \times \frac{22}{7} \times 7 \times 7 (14 + 2 \times 7)$$

$$= \frac{154}{3} \times 28$$

$$= \frac{4312}{3}$$

$$= 1437.33 \text{ (approx) cm}^3 \quad 2$$

34. (A) Let First term = a

$$\text{Common difference} = $d$$$

$$\frac{a_{11}}{a_{18}} = \frac{2}{3}$$

$$\frac{a + 10d}{a + 17d} = \frac{2}{3}$$

$$(\because a_{11} = a + (11 - 1)d = a + 10d$$

$$a_{18} = a + (18 - 1)d = a + 17d)$$

$$3a + 30d = 2a + 34d$$

$$a = 4d$$

$\dots(i)$

Ratio of 5th term to 21st term is

$$\frac{S_5}{S_{21}} = \frac{a + 4d}{a + 20d}$$

Substitute value of $a = 4d$ from (i) we get

$$\begin{aligned}\frac{S_5}{S_{21}} &= \frac{4d + 4d}{4d + 20d} \\ &= \frac{8d}{24d}\end{aligned}$$

$$\frac{S_5}{S_{21}} = \frac{1}{3}$$

Ratio of S_5 to S_{21} is

$$\frac{S_5}{S_{21}} = \frac{\frac{5}{2}(2a + 4d)}{\frac{21}{2}(2a + 20d)}$$

$$\left[\because S_n = \frac{n}{2}(2a + (n-1)d) \right]$$

$$= \frac{5(2a + 4d)}{21(2a + 20d)} \quad \dots(ii) \quad 1$$

Substitute $a = 4d$ in equation (ii)

$$\begin{aligned}\frac{S_5}{S_{21}} &= \frac{5(8d + 4d)}{21(8d + 20d)} \\ &= \frac{5 \times 12d}{21 \times 28d} = \frac{60d}{588d}\end{aligned}$$

$$\therefore \frac{S_5}{S_{21}} = \frac{5}{49}$$

Hence $a_5 : a_{21} = 1 : 3$
 $S_5 : S_{21} = 5 : 49$

OR

(B) $S_n = \frac{n}{2}[2a + (n-1)d]$

$$S_6 = 36 \quad \text{(Given)}$$

$$\therefore \frac{6}{2}[2a + (6-1)d] = 36$$

$$2a + 5d = 12 \quad \dots(i)$$

$$S_{16} = 256 \quad \text{(Given)}$$

$$\frac{16}{2}[2a + (6-1)d] = 256$$

$$2a + 15d = 32 \quad \dots(ii) \quad 1$$

Subtract (i) from (ii)

$$2a + 15d = 32$$

$$2a + 5d = 12$$

$$\begin{array}{r} - \\ - \\ \hline 10d = 20 \end{array}$$

Substitute $d = 2$ in equation (i)

$$2a + 5 \times 2 = 12$$

$$2a = 12 - 10$$

$$2a = 2$$

$$a = 1$$

Thus, the sum of first 10 terms of AP

$$S_{10} = \frac{10}{2}[2 \times 1 + (10-1)2]$$

$$= 5(2 + 18)$$

$$= 5 \times 20$$

$$= 100 \quad 2$$

35.

Mass (in gms)	No. of Apples (f_i)	Class mark $x_i = \frac{UL + LL}{2}$	$f_i x_i$
80 - 100	20	90	1800
100 - 120	60	110	6600
120 - 140	70	130	9100
140 - 160	$x = 40$	150	6000
160 - 180	60	170	10200
	$\Sigma f_i = 210 + x$		$\Sigma f_i x_i = 33700$

(i) Total Number of apples = 250

$$210 + x = 250$$

$$x = 40$$

$$\text{Mean } (\bar{x}) = \frac{\Sigma f_i x_i}{\Sigma f_i} = \frac{33700}{250}$$

$$= 134.8$$

(ii) Here modal class is 120 - 140 as it has maximum frequency. 1

$$\therefore x_k = 120, h = 20, f_k = 70, f_{k-1} = 60, f_{k+1} = 40$$

$$\text{Mode} = x_k + \left[h \times \left(\frac{f_k - f_{k-1}}{2f_k - f_{k-1} - f_{k+1}} \right) \right]$$

$$= 120 + \left[20 \times \left(\frac{70 - 60}{2 \times 70 - 60 - 40} \right) \right]$$

$$= 120 + \left[20 \times \left(\frac{10}{140 - 100} \right) \right]$$

$$= 120 + \left(20 \times \frac{10}{40} \right)$$

$$= 120 + 5$$

$$= 125 \quad 1$$

SECTION — E

36. Monthly fees paid by each poor children = ₹ x

Monthly fees paid by each rich children = ₹ y

(i) For batch I

$$20x + 5y = 9000 \quad \dots(i)$$

For batch II

$$5x + 25y = 26000 \quad \dots(ii) \quad 1$$

(ii) Multiply equation (i) by 5 we get

$$100x + 25y = 45000 \quad \dots(iii)$$

Subtract (ii) from (iii)

$$100x + 25y = 45000$$

$$5x + 25y = 26000$$

$$\begin{array}{r} - \\ - \\ \hline 95x = 19000 \end{array}$$

$$x = \frac{19000}{95} = 200$$

Thus, monthly fee paid by Poor Child = ₹ 200

OR

Substitute value of x in equation (i)

$$20 \times 200 + 5y = 9000$$

$$5y = 9000 - 4000$$

$$y = \frac{5000}{5} = 1000$$

Monthly fee paid by Rich child = ₹ 1000

Difference in monthly fee paid by poor child and a rich child = 1000 – 200

$$= ₹ 800 \quad 2$$

(iii) Poor children = 10

Rich children = 20

Total monthly collection of fees from batch II

$$= 10 \times 200 + 200 \times 800$$

$$= 2000 + 16000$$

$$= ₹ 18000 \quad 1$$

37. (i) In $\triangle BPO$

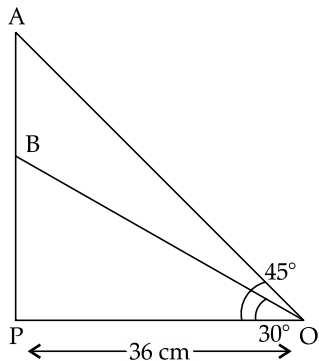

$$\cos \theta^\circ = \frac{B}{H}$$

$$\Rightarrow \cos 30^\circ = \frac{OP}{OB}$$

$$\frac{\sqrt{3}}{2} = \frac{36}{OB}$$

$$OB = \frac{36 \times 2}{\sqrt{3}} = \frac{72}{\sqrt{3}}$$

$$= \frac{72}{\sqrt{3}} \times \frac{\sqrt{3}}{\sqrt{3}}$$

$$= \frac{72\sqrt{3}}{3} = 24\sqrt{3} \text{ cm} \quad 1$$

Thus, the length of wire from O to top of Section B = $24\sqrt{3}$ cm.

(ii) $AB = AP - BP$

In $\triangle BPO$

$$\tan 30^\circ = \frac{P}{B} = \frac{BP}{OP}$$

$$\frac{1}{\sqrt{3}} = \frac{BP}{36}$$

$$BP = \frac{36}{\sqrt{3}} \times \frac{\sqrt{3}}{\sqrt{3}}$$

$$= \frac{36\sqrt{3}}{3} = 12\sqrt{3} \text{ cm} \quad 1$$

In $\triangle APO$

$$\tan 45^\circ = \frac{AP}{PO}$$

$$1 = \frac{AP}{36}$$

$$\Rightarrow AP = 36 \text{ cm}$$

$$\begin{aligned} \text{Distance } AB &= 36 - 12\sqrt{3} \\ &= 36 - 20.78 \\ &= 15.22 \text{ cm} \end{aligned} \quad 1 \text{ (approx)}$$

OR

$$\text{Area of } \triangle OPB = \frac{1}{2} \times \text{Base} \times \text{height}$$

$$= \frac{1}{2} \times 36 \times 12\sqrt{3}$$

$$= 216\sqrt{3} \text{ cm}^2$$

$$= 374.12 \text{ cm}^2 \quad 2 \text{ (approx)}$$

(iii) Height of Section A from base of tower = AP

In $\triangle APO$,

$$\tan 45^\circ = \frac{AP}{PO}$$

$$1 = \frac{AP}{PO}$$

$$AP = 36 \text{ cm.} \quad 1$$

38. (i) Total number of balls = 15

Number of Ball bears number 8 = 1

$$\therefore P(\text{Getting ball bears number 8}) = \frac{1}{15} \quad 1$$

(ii) Number of balls having even numbers = 7

$$\therefore P(\text{Getting even number balls}) = \frac{7}{15} \quad 2$$

OR

Number of balls bearing a number, which is multiple of 3 = 5

$$\therefore P(\text{Getting balls having multiple of 3}) = \frac{5}{15}$$

$$= \frac{1}{3} \quad 2$$

(iii) Solid coloured balls = 8

Number of solid coloured balls having an even number = 4.

$$\therefore P(\text{Getting Solid Coloured even number Ball}) = \frac{4}{15} \quad 1$$

Outside Delhi Set-II

30/6/2

SECTION — A

6. Option (c) is correct

Explanation: Smallest two digit number = 10

Smallest composite number = 4

Factor of 4 = 2^2

Factor of 10 = 2×5

\therefore LCM of 4 and 10 = $2^2 \times 5 = 20$.

7. Option (a) is correct

Explanation: Refer the following figure.

x-coordinate = -4

So, Distance of point along x-axis from Origin

$$= -4 \text{ unit.}$$

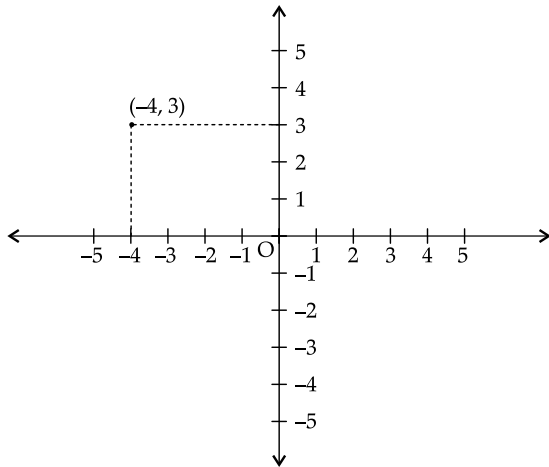

8. Option (a) is correct

Explanation: Given Polynomial = $x^2 + 3x + k$

$$f(x) = x^2 + 3x + k$$

One of the zeroes of polynomial = 2

$$\therefore f(2) = 0$$

$$f(2) = x^2 + 3x + k$$

$$0 = 4 + 6 + k$$

$$0 - 10 = k$$

$$\therefore k = -10$$

16. Option (c) is correct

Explanation: Prime Number less than 23 = 2, 3, 5, 7, 11, 13, 17, 19

\therefore Discs having Prime number less than 23 = 8

Total Number of discs = 90

P(Getting Disc having Prime number less than 23)

$$= \frac{8}{90} = \frac{4}{45}$$

17. Option (c) is correct

Explanation: Given $2y = 4x + 5$

Any point where the line intersects with x -axis is of the form $(x, 0)$ i.e., at that point 'y' coordinate is 0.

Put $y = 0$ in given equation

$$2 \times 0 = 4x + 5$$

$$-5 = 4x$$

$$x = \frac{-5}{4}$$

\therefore Coordinates are $\left(-\frac{5}{4}, 0\right)$

18. Option (d) is correct

Explanation: $\cos^4 A - \sin^4 A$

$$(\cot^2 A)^2 - (\sin^2 A)^2$$

$$= (\cos^2 A + \sin^2 A)(\cos^2 A - \sin^2 A)$$

$$[\because a^2 - b^2 = (a + b)(a - b)]$$

$$= 1(\cos^2 A - \sin^2 A)$$

$$(\because \cos^2 A + \sin^2 A = 1)$$

$$= \cos^2 A - \sin^2 A$$

$$= \cos^2 A - (1 - \cos^2 A)$$

$$= \cos^2 A - 1 + \cos^2 A$$

$$= 2\cos^2 A - 1$$

SECTION — B

24. Let the point on x -axis be $P(x_1, 0)$ and $Q(x_2, 0)$ which are at distance of 10 units from point $A(11, -8)$

$$\Rightarrow PA = QA$$

$$\begin{aligned} \text{or } PA^2 &= QA^2 \\ \Rightarrow (11 - x_1)^2 + (-8 - 0)^2 &= (11 - x_2)^2 + (-8 - 0)^2 \\ &= 10^2 \end{aligned}$$

$$(11 - x)^2 + (-8)^2 = 100$$

$$121 + x^2 - 22x + 64 = 100$$

$$x^2 - 22x + 185 - 100 = 0$$

$$x^2 - 17x - 5x + 85 = 0$$

$$x(x - 17) - 5(x - 17) = 0$$

$$(x - 17)(x - 5) = 0$$

$$x - 17 = 0 \quad \text{and } x - 5 = 0$$

$$x = 17 \quad \text{or } x = 5$$

So, the points are $(17, 0)$ and $(5, 0)$.

SECTION — C

26. Given: $OA = 7$ cm

AB and CD are diameters

$\therefore OD = OB = OC = OA = 7$ cm

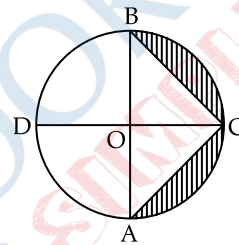

$$AB = 2 \times \text{Radius}$$

$$= 14 \text{ cm}$$

Area of shaded segment = Area of semicircle ACB - Area of $\triangle ABC$

$$\text{Area of semicircle } ACB = \frac{1}{2} \pi r^2$$

$$= \frac{1}{2} \times \frac{22}{7} \times 7 \times 7$$

$$= 77 \text{ cm}^2$$

$$\text{Area of } \triangle ABC = \frac{1}{2} \times \text{Base} \times \text{Height}$$

$$= \frac{1}{2} \times AB \times OC$$

$$= \frac{1}{2} \times 14 \times 7$$

$$= 49 \text{ cm}^2$$

\therefore Area of shaded segment = $77 - 49 = 28 \text{ cm}^2$ 2

27. Given: $\sin \theta + \cos \theta = p$

$$\sec \theta + \operatorname{cosec} \theta = q$$

$$q(p^2 - 1) = p$$

$$\text{LHS: } q(p^2 - 1)$$

$$= \sec \theta + \operatorname{cosec} \theta \left[(\sin \theta + \cos \theta)^2 - 1 \right]$$

$$= \left(\frac{1}{\cos \theta} + \frac{1}{\sin \theta} \right) (\sin^2 \theta + \cos^2 \theta + 2 \sin \theta \cos \theta - 1)$$

$$= \frac{\sin \theta + \cos \theta}{\sin \theta \cos \theta} (1 + 2 \sin \theta \cos \theta - 1)$$

$$= \frac{\sin \theta + \cos \theta}{\sin \theta \cos \theta} \times 2 \sin \theta \cos \theta$$

$$= 2(\sec \theta + \operatorname{cosec} \theta)$$

$$= 2p$$

$$= \text{RHS}$$

Hence Proved. 2

SECTION — D

34. Radius of cone = Radius of hemisphere = 3.5 cm
 Height of cone = $9.5 - 3.5$
 $= 6$ cm **1**
 Volume of solid = Volume of cone + Volume of Hemisphere
 $= \frac{1}{3}\pi r^2 h + \frac{2}{3}\pi r^3$ **2**
 $= \frac{1}{3}\pi r^2 (h + 2r)$
 $= \frac{1}{3} \times \frac{22}{7} \times 3.5 \times 3.5 \times (6 + 2 \times 3.5)$
 $= \frac{385}{30} \times 13$
 $= 166.83 \text{ cm}^3$ (approx.) **2**

35. (A)(i) Numbers between 100 – 200 divisible (i) by 9 are 108, 117, 126 198.
 Here, $a = 108$, $d = 117 - 108 = 9$ and $a_n = 198$
 $a + (n - 1)d = 198$
 $108 + (n - 1)9 = 198$
 $9n - 9 = 90$
 $9n = 99$
 $n = 11$

Now, $S_n = \frac{n}{2}[2a + (n - 1)d]$
 $S_{11} = \frac{11}{2}[2 \times (108) + (11 - 1)9]$
 $S_{11} = \frac{11}{2}[216 + 90]$
 $= \frac{11}{2} \times 306$
 $= 11 \times 153$
 $= 1683$ **2**

- (ii) Numbers between 100 and 200 = 101, 102, 103, 199
 Here $a = 101$, $d = 1$, $a_n = 199$
 $199 = a + (n - 1)d$
 $199 = 101 + (n - 1)1$
 $199 - 101 = n - 1$

$$98 + 1 = n$$

$$n = 99$$
 1

Now $S_n = \frac{n}{2}[2a + (n - 1)d]$
 $S_n = \frac{99}{2}[2 \times 101 + (99 - 1)1]$
 $= \frac{99}{2}(202 + 98)$
 $= \frac{99}{2} \times 300$
 $= 14850$ **2**
 Thus, sum of integers between 100 and 200 which are not divisible by 9
 $= 14850 - 1683$
 $= 13167$

OR

- (B) n^{th} term of an AP = x
 $a = -4$
 $d = -1 - (-4) = -1 + 4 = 3$
 $S_n = 437$

$$S_n = \frac{n}{2}[2a + (n - 1)d]$$
 1

$$437 = \frac{n}{2}[-8 + (n - 1)3]$$

$$874 = n(-8 + 3n - 3)$$

$$874 = -11n + 3n^2$$

$$3n^2 - 11n - 874 = 0$$

$$3n^2 - 57n + 46n - 874 = 0$$

$$3n(n - 19) - 46(n - 19) = 0$$

$$(3n - 46)(n - 19) = 0$$

$$n = \frac{46}{3}, n = 19$$
 2

$\therefore n = 19$ (n cannot be in fraction)
 So, $x = a + (n - 1)d$
 $= -4 + (19 - 1)3$
 $= -4 + 18 \times 3$
 $= -4 + 54$
 $= 50$

Hence, value of $x = 50$ **2****Outside Delhi Set-III****30/6/3****SECTION — A**

1. Option (b) is correct

Explanation: According to distance formula

$$d = \sqrt{(x_2 - x_1)^2 + (y_2 - y_1)^2}$$

Here, $x_1 = 0$, $y_1 = 5$, $x_2 = -3$ and $y_2 = 1$

Substitute values in formula

$$d = \sqrt{(-3 - 0)^2 + (1 - 5)^2}$$

$$= \sqrt{(-3)^2 + (-4)^2}$$

$$= \sqrt{9 + 16}$$

$$= \sqrt{25}$$

$$= 5 \text{ units}$$

2. Option (b) is correct

Explanation: $\tan \theta = \frac{x}{y}$ (given)

$$\tan \theta = \frac{\text{Perpendicular}}{\text{Base}}$$
 (formula)

$\therefore \frac{P}{B} = \frac{x}{y}$

So, In Right Angle Triangle
By Pythagoras Theorem

$$H^2 = P^2 + B^2$$

$$= x^2 + y^2$$

$$H = \sqrt{x^2 + y^2}$$

$$\cos \theta = \frac{\text{Base}}{\text{Hypotenuse}}$$

$$= \frac{y}{\sqrt{x^2 + y^2}}$$

3. Option (a) is correct

Explanation:

$$\begin{aligned} 3x^2 + 11x - 4 &= 0 \\ 3x^2 + 12x - x - 4 &= 0 \\ 3x(x + 4) - 1(x + 4) &= 0 \\ (3x - 1)(x + 4) &= 0 \\ 3x - 1 = 0 \text{ and } x + 4 &= 0 \\ 3x = 1 \quad \quad \quad x &= -4 \\ x = \frac{1}{3} \end{aligned}$$

Thus, zeroes are $\left(\frac{1}{3}, -4\right)$

16. Option (d) is correct

Explanation: $x^2 - (p + q)x + k = 0$

p is a root of Quadratic equation

$$\begin{aligned} \therefore \quad \quad \quad x &= p \\ \text{So, } p^2 - (p + q)p + k &= 0 \\ p^2 - p^2 - pq + k &= 0 \\ -pq + k &= 0 \\ \therefore \quad \quad \quad k &= pq \end{aligned}$$

17. Option (b) is correct

Explanation: Total cards (3, 4 ... 20) = 18

Number of even cards = 9

$$\text{Probability of getting even} = \frac{9}{18} = \frac{1}{2}$$

18. Option (a) is correct

Explanation:

$$\begin{aligned} ax + by &= c \\ lx + my &= n \end{aligned}$$

This can be written as

$$\begin{aligned} ax + by - c &= 0 \\ ax + by - n &= 0 \end{aligned}$$

For equations to have unique solution

$$\frac{a_1}{a_2} \neq \frac{b_1}{b_2}$$

Here, $a_1 = a, a_2 = l, b_1 = b$ and $b_2 = m$

$$\Rightarrow \frac{a}{l} = \frac{b}{m} \Rightarrow am \neq bl$$

SECTION — B

21.

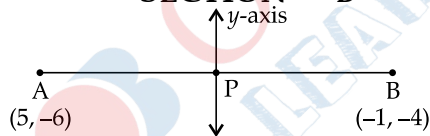

According to section Formula,

If point (x, y) divides the line joining the points (x_1, y_1) and (x_2, y_2) in the ratio $m : n$, then

$$(x, y) = \left(\frac{mx_2 + nx_1}{m + n}, \frac{my_2 + ny_1}{m + n} \right)$$

Let point P be required point

Since, point P is on y -axis

So, it is of form $P(0, y)$

Let ratio be $m : n$

$$\Rightarrow \frac{mx_2 + nx_1}{m + n} = 0$$

$$\begin{aligned} -1m + 5n &= 0 \\ -1m &= -5n \end{aligned}$$

$$\frac{m}{n} = \frac{5}{1}$$

Thus, ratio in which y -axis divides the line = 5 : 1. 1

SECTION — C

26. To Prove:

$$(\sin \theta + \cos \theta)(\tan \theta + \cot \theta) = \sec \theta + \operatorname{cosec} \theta$$

$$\begin{aligned} \text{LHS} &= (\sin \theta + \cos \theta) \left(\frac{\sin \theta}{\cos \theta} + \frac{\cos \theta}{\sin \theta} \right) \\ &= (\sin \theta + \cos \theta) \left(\frac{\sin^2 \theta + \cos^2 \theta}{\sin \theta \cos \theta} \right) \\ &= \frac{\sin \theta + \cos \theta}{\sin \theta \cos \theta} \\ &= \frac{\sin \theta}{\sin \theta \cos \theta} + \frac{\cos \theta}{\sin \theta \cos \theta} \quad (\because \sin^2 \theta + \cos^2 \theta = 1) \\ &= \frac{1}{\cos \theta} + \frac{1}{\sin \theta} \quad 1 \\ &= \sec \theta + \operatorname{cosec} \theta \\ &= \text{RHS} \quad \left(\because \frac{1}{\cos \theta} = \sec \theta \right. \\ &\quad \left. \text{and } \frac{1}{\sin \theta} = \operatorname{cosec} \theta \right) \end{aligned}$$

Hence Proved. 2

27. (A) Let Natural Number = x

According to question,

$$x + 12 = \frac{160}{x}$$

$$\Rightarrow x^2 + 12x = 160 \quad 1$$

$$x^2 + 12x - 160 = 0$$

$$x^2 + 20x - 8x - 160 = 0$$

$$x(x + 20) - 8(x + 20) = 0$$

$$(x + 20)(x - 8) = 0$$

$$x + 20 = 0 \text{ and } x - 8 = 0$$

$$x = -20 \text{ and } x = 8$$

Natural Number is always greater than zero.

$$\therefore x = 8$$

OR

(B) Let one root of equation = α

other root = 3α

$$\text{In, } x^2 + 12x - k = 0$$

$$a = 1, b = 12 \text{ and } c = -k$$

$$\text{sum of roots} = \alpha + \beta = \frac{-b}{a} = -12 \quad 1$$

$$\alpha + 3\alpha = -12$$

$$4\alpha = -12$$

$$\alpha = -3 \quad 1$$

$$\text{Product of Roots} = \alpha\beta = \alpha \times 3\alpha = -k$$

$$3\alpha^2 = -k$$

$$3(-3)^2 = -k$$

$$27 = -k \quad 1$$

Thus, value of $k = 27$

SECTION — D

32. (A) Given: $S_7 = 182$

$$\frac{a_4}{a_{17}} = \frac{1}{5}$$

We know that,

$$S_n = \frac{n}{2}[2a + (n-1)d]$$

$$182 = \frac{7}{2}[2a + 6d]$$

$$\frac{182 \times 2}{7} = 2a + 6d$$

$$26 \times 2 = 2(a + 3d)$$

$$26 = a + 3d \quad \dots(i)$$

Also,

$$a_n = a + (n - 1)d$$

$$a_4 = a + 3d$$

$$a_{17} = a + 16d$$

$$\frac{a_4}{a_{17}} = \frac{a + 3d}{a + 16d}$$

$$\frac{1}{5} = \frac{a + 3d}{a + 16d}$$

$$a + 16d = 5a + 15d$$

$$d = 4a \quad \dots(ii)$$

Substitute value of equation (ii) in (i)

$$a + 3d = 26$$

$$a + 3 \times 4a = 26$$

$$13a = 26$$

$$a = 2$$

So, $d = 4a = 4 \times 2 = 8$

Therefore, AP will be

2, 10, 18, 26

(B) Given

$$S_q = 63q - 3q^2$$

∴

$$S_1 = 63 \times 1 - 3 \times 1^2$$

$$= 63 - 3 = 60$$

$$S_2 = 63 \times 2 - 3 \times 2^2$$

$$= 126 - 12 = 114$$

Now,

$$a_1 = \text{Sum of first term}$$

$$a_1 = 60$$

$$a_2 = \text{Difference of } S_2 \text{ and } S_1$$

$$a_2 = 114 - 60 = 54$$

Common difference

$$(d) = a_2 - a_1,$$

$$= 54 - 60$$

$$= -6$$

Now

$$a_p = -60$$

$$a + (p - 1)d = -60$$

$$60 + (p - 1)(-6) = -60$$

$$(p - 1)(-6) = -120$$

$$p - 1 = 20$$

$$p = 21$$

Thus, value of $p = 21$

Now,

$$a_{11} = a + (11 - 1)d$$

$$= 60 + 10 \times -6$$

$$= 60 - 60$$

$$= 0$$

33. (A) Given: ABCD is a Parallelogram

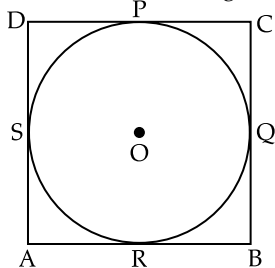

To Prove: ABCD is a rhombus

Proof: $AS = AR$

$BR = BQ$

$CP = CQ$

$DP = DS$

1

(∵ Tangents drawn to a circle from an exterior point are equal in length)

$AS + DS + BQ + CQ = AR + DP + BR + CP$

$AD + BC = AB + CD$

$AD + AD = AB + AB$

(Since, $AD = BC, AB = CD$)

Opposite sides of parallelogram

$2AD = 2AB$

$\Rightarrow AD = AB$

$\therefore AD = BC = AB = CD.$

Therefore ABCD is a rhombus.

OR

33. (B) Given: PQ and PR are tangents to a circle

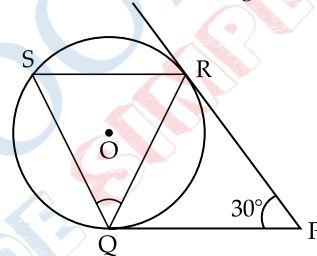

$\angle RPQ = 30^\circ$

To Find: $\angle RQS$

Solution: $PR = PQ$

(∵ tangents drawn from an external point to a circle are equal in length)

$\therefore \angle PRQ = \angle PQR$

(Angles opposite to equal side are equal)

Now, In ΔPQR

$\angle RPQ + \angle PRQ + \angle PQR = 180^\circ$

$\angle PRQ + \angle PRQ = 180^\circ - 30^\circ$

$2\angle PRQ = 150^\circ$

$\angle PRQ = 75^\circ$

$\angle PQR = 75^\circ$

∴

$\angle RQP = \angle RSQ$

$= 75^\circ$

(Alternate segment)

Now,

$RS \parallel PQ$

∴ RQ is transversal

⇒

$\angle RQP = \angle SRQ = 75^\circ$

(Alternate angles)

$\angle SRQ = \angle RSQ = 75^\circ$

(From above)

∴

$QS = QR$

(sides opposite to equal angles are equal)

∴ ΔQSR is an Isosceles triangle.

In ΔQSR

$\angle QSR + \angle SRQ + \angle RQS = 180^\circ$

$75^\circ + 75^\circ + \angle RQS = 180^\circ$

$\angle RQS = 30^\circ$

Hence, value of $\angle RQS = 30^\circ$.