

SEIT
QUALITÄT



1896
PRÄZISION

SCHILD

Heinrich

- AUTOMATIC -
SWISS GMT

ETA 2893-2

LIMITED EDITION

INSTRUCTION
MANUAL



HONOLULU LOS ANGELES
ANCHORAGE

16
15
14

14

13

SAO PAULO
AUCKLAND

12

MADE IN SWITZERLAND

11

SYDNEY
NOUMEA

10

GMT

AUTOMATIC
TWENTY-ONE JEWELS

XII

XI

X

IX

VIII

VII

VI

V

IV

III

II

I



SCHILD



SWISS MOVEMENT GMT AUTOMATIC

This Limited Edition timepiece is equipped with a Swiss Made self-winding Mechanical Automatic movement manufactured by ETA.

It does not need a battery. It is powered by the motions of the user's own wrist during the wear of the watch.

You may also choose to wind the watch manually.

A) DISPLAY

Crown for Inner
World Cities
Turning Bezel

Date

Minute Hand

24 Hours
Dial Ring

Screw
Down
Crown

Hour
Hand

Second
Hand

GMT
Hand

Inner World Cities
Turning Bezel

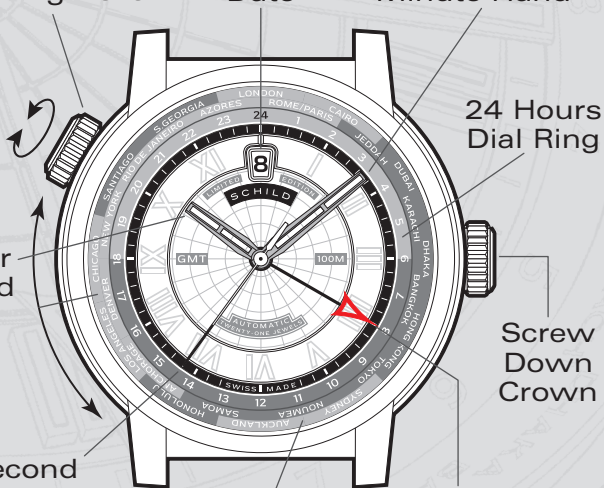

B) PLEASE READ THE FOLLOWING BEFORE UNSCREWING THE CROWN

SCREW-DOWN CROWN

Screw-down crowns are used to ensure water resistance. **ALWAYS** be certain that your crown is securely screwed down (Position [0] is secured. Positions [1], [2] and [3] are not secured for water resistance).

Do not unscrew your crown while you are in any environment where moisture is present.

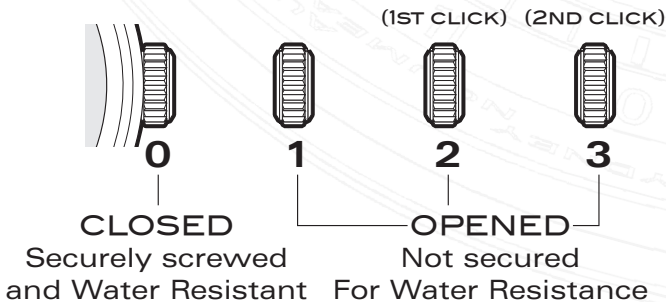

C) USING THE SCREW-DOWN CROWN

Do not pull the crown unless it is **UNSCREWED** first:

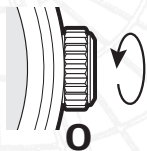

TO UNSCREW: Turn the crown anti-clockwise until it turns freely without tension.

GENTLY pull the crown out to the other desired positions for watch setting.

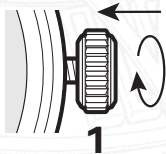

TO SCREW: Push the crown ALL THE WAY IN (towards the watch) THEN begin to turn clockwise until it is securely screwed down.

NOTE: Failure to SECURELY screw down the crown after setting the watch may affect its water resistance.

D) WINDING THE MAINSPRING

THIS WATCH IS AN AUTOMATIC
WATCH EQUIPPED WITH A MANUAL
WINDING MECHANISM.

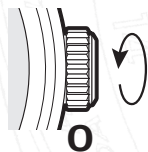

1. Unscrew the crown by turning it anti-clockwise.

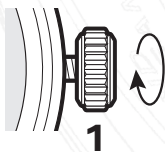

2. When it is in position [1], turn the crown clockwise to wind. Wind 5-10 times and it will start to move naturally after shaking slightly.

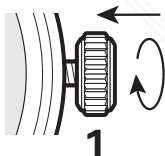

3. Push the crown in then screw it securely.

NOTE: This watch **MUST** be worn for at least 8 (Eight) hours each day to ensure it is fully wound.

An automatic watch will only wind when the watch is on your wrist and your arm moves.

Winding the watch by the crown will put power on the spring but not enough to allow the watch to function fully.

If your watch stops overnight or loses time it means it is not being fully wound.

IMPORTANT NOTE:

1. If your watch is running smoothly, please do not wind the crown to avoid overwinding the movement. Provided you are wearing the watch frequently, your watch should have sufficient power to operate without any fuss.
2. If your watch has stopped running after a period of not wearing the watch, gently move the watch side to side 20 to 30 times to move the rotor or gently turn the crown 5 to 10 times to get the second hand run at its normal speed.

E) TIME SETTING

1. Unscrew the crown and pull it out to position [3] (2nd click).
2. Turn the crown anti-clockwise to set the correct time.
3. Push the crown in then screw it securely.

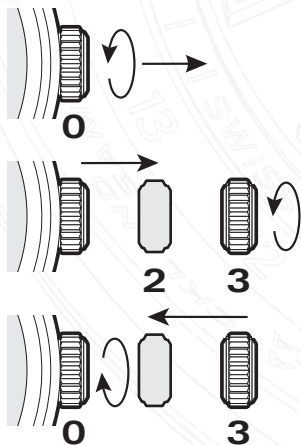

- * Take a.m./p.m. into consideration when setting the hour and minute hands to the desired time.
- * Always be certain that your crown is **SECURELY SCREWED**; this will prevent moisture from entering in.

F) DATE SETTING

1. Unscrew the crown and pull it out to position [2] (1st click).
2. Turn the crown anti-clockwise to set the correct date.
3. Push the crown in then screw it securely.

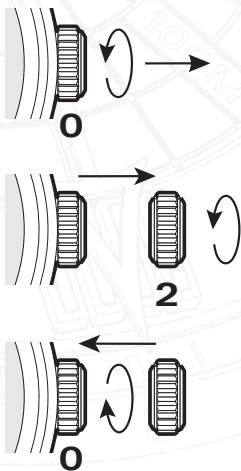

* Do not set the date between 9:00 P.M. and 4:00 A.M.

G) HOW TO SET THE SECOND TIME ZONE

You may wish to set your main time to your current location and the second time read out via the GMT hand to another location for at a glance read out of two timezones at the same time.

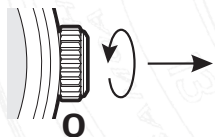

1. Unscrew the crown and pull it out to position **[2]** (**1st click**).

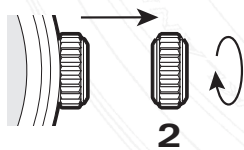

2. Turn the crown clockwise to set the correct time in the second timezone by pointing the GMT hand to the correct timezone on the 24 Hours Dial Ring.

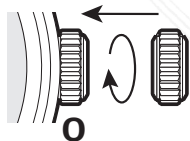

H) HOW TO READ THE SECOND TIME ZONE

The GMT function allows travelers to simultaneously read their local time and a second time zone.

The local time is indicated by the conventional hour and minute and seconds display.

The second time zone is indicated by the triangle tipped GMT hand read against markings on the 24 Hours Dial ring.

Example :

You are traveling to Hong Kong from Zurich.

You will adjust the local time once in Hong Kong with the conventional hour and minute hands.

You are able to adjust the GMT hand to read off the time in Zurich by setting it 6 hours behind the time in Hong Kong.

Example:

Local Time:

Hong Kong: 5pm

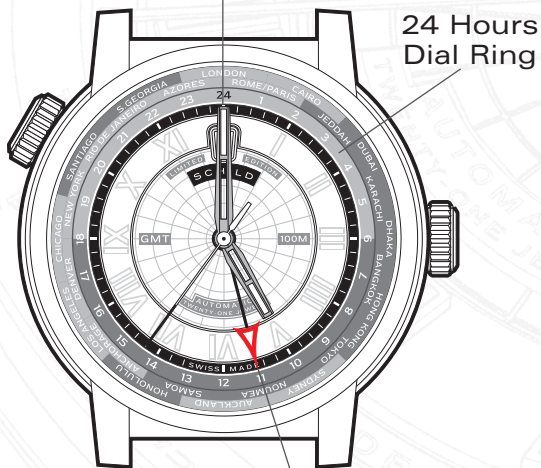

**24 Hours
Dial Ring**

**Second
Timezone:
Zurich: 11am**

The triangle tipped GMT hand is always indicating Zurich time during your trip in Hong Kong.

Example: the present time is
10:09 p.m.(Tokyo time)

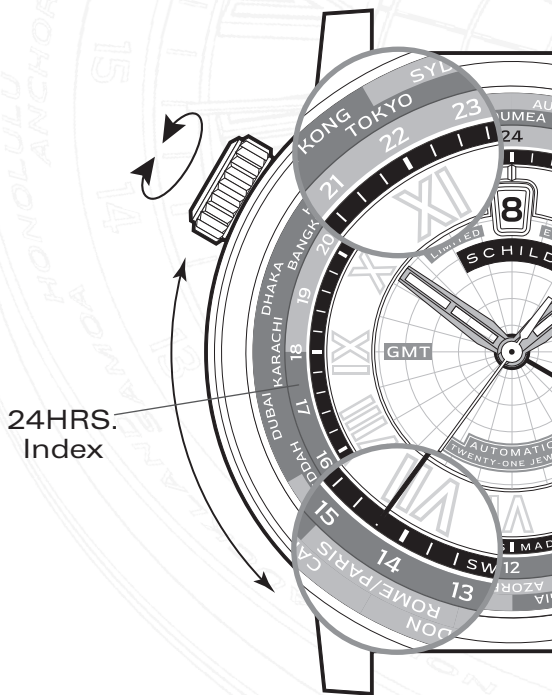

The approximate time of all the major cities can be determined by using the rotating bezel.

Example: Perhaps you want to know the time of Paris while in Tokyo.

[The main time display is set according to the time in Tokyo.]

1. Read and change the present time [hour] into 24-hour format.
[10 o'clock p.m. --> 22:00]
2. Adjust the city name [TOKYO] above the rotating bezel to 22:00 of 24-hour-scale.
3. You can determine the time of [PARIS] is 14:00 [2:00 p.m.] by reading the 24-hour scale corresponding to the position of the city name displayed above the rotating bezel.

The time difference between major cities is in hours only, the minutes remain the same.

You can find out the time of other cities in the same way, however be sure to account for daylight savings time as this cannot be calculated using the bezel ring or dial ring.

J) HOW TO USE A DUAL DEPLOYANT CLASP

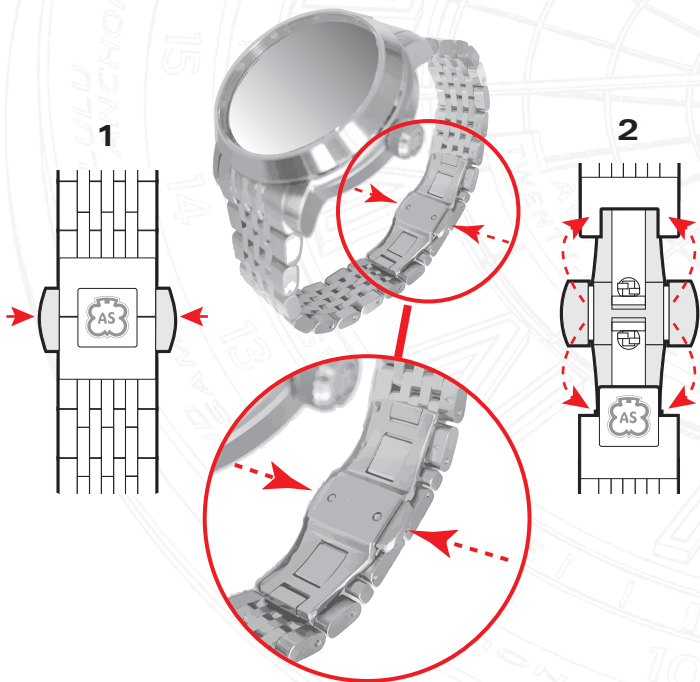

1. Press the buttons on both sides of the clasp.
2. The Buckle will release and open.

K) HOW TO CHANGE THE BRACELET TO STRAP

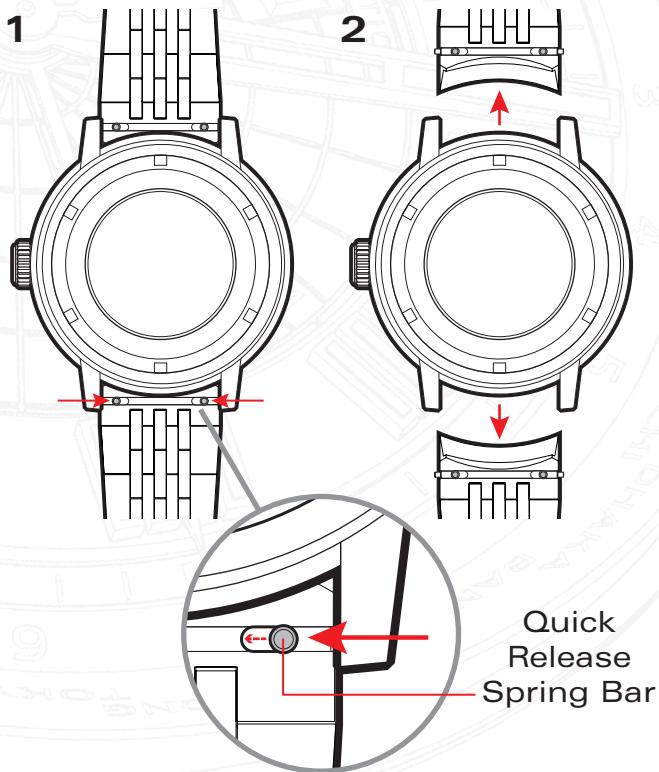

3

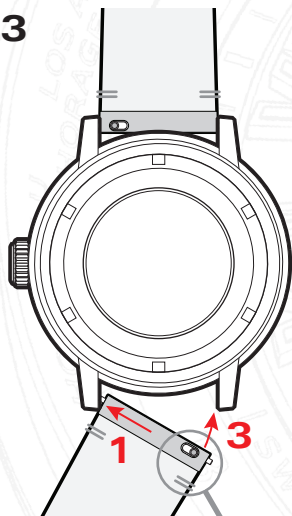

4

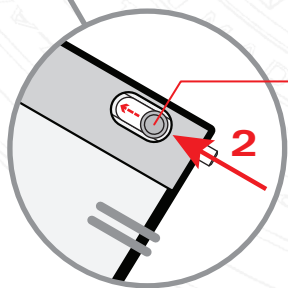
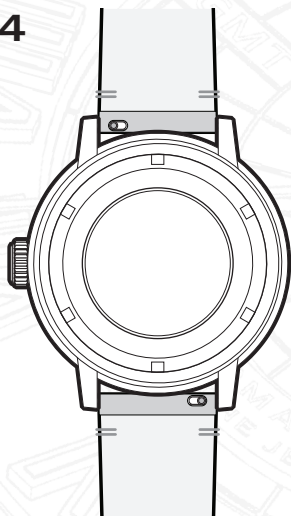

Quick
Release
Spring Bar

CARE & MAINTENANCE

Each **SCHILD** timepiece is designed and manufactured to exceed the highest of standards. In order to ensure optimal performance and longevity from your timepiece, please review the simple guidelines for care and maintenance of your new **SCHILD** timepiece.

Your timepiece should be cleaned with a soft cloth and water only. Do not submerge your timepiece. Your timepiece should be rinsed clean and dried with a soft cloth after any saltwater use.

We advise having your timepiece serviced every 3 or 4 years to ensure long use and trouble free operation.

While your **SCHILD** timepiece has been designed and built to exacting specification, it is important to avoid the following conditions: extreme heat or cold, as well as prolonged periods of exposure to direct sunlight, exposure to wet conditions that exceed your timepiece's water rating (see case back).

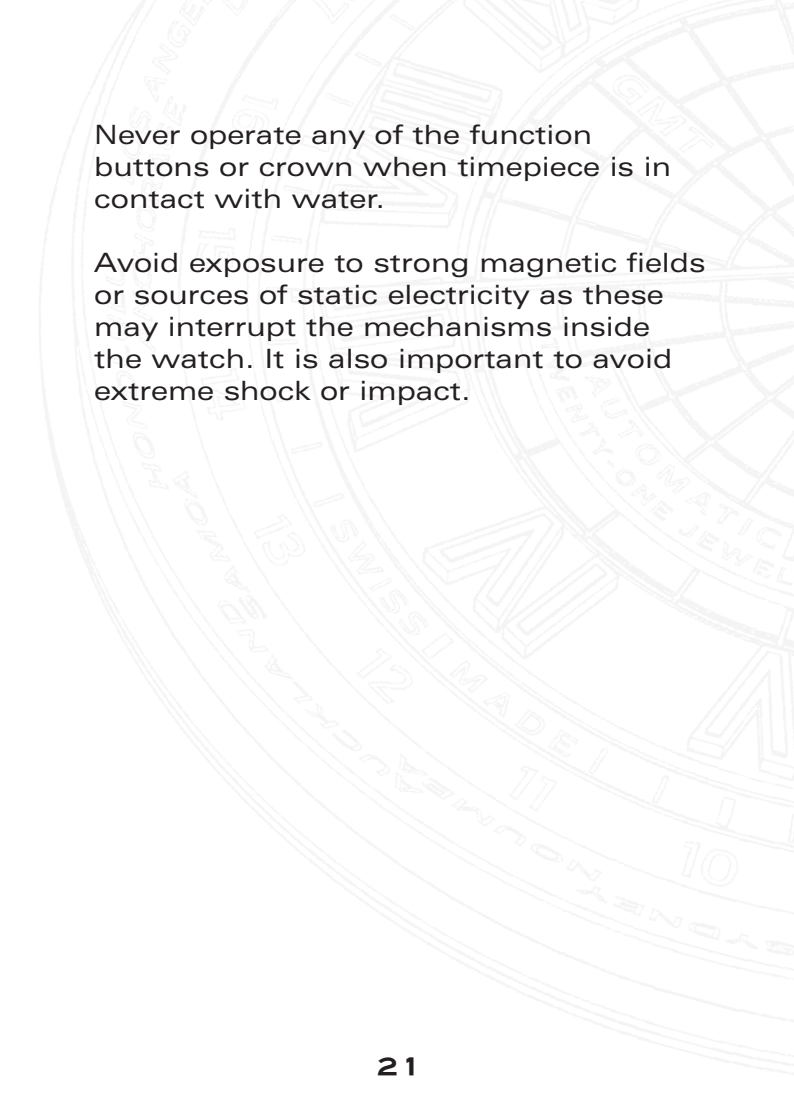

Never operate any of the function buttons or crown when timepiece is in contact with water.

Avoid exposure to strong magnetic fields or sources of static electricity as these may interrupt the mechanisms inside the watch. It is also important to avoid extreme shock or impact.

WATER RESISTANCE

The water resistance indicated on your timepiece serves only as a guide.

Actual water resistance may vary depending on a number of important factors including temperature, water salinity, and actual use under water.

The water resistance of your timepiece may eventually be compromised over time with general wear and tear and the use of your watch under adverse conditions.

Note that you should NEVER wear your watch in a jacuzzi, hot shower or steam room where steam may enter the case despite the watertight seals used to protect your watch.

The steam may cause condensation inside your watch, which may affect and damage the inner workings of your watch – which would also not be covered by the warranty.

SERVICE LOG

Use this area to record any after care of your timepiece.

DATE	NOTES:	LOCATION



LIMITED

SCHILD

EDITIC

100M

ROME/PARIS CAI

KARACHI DHAKA BANGKOK

HONG KONG TOKYO



SCHILD



VOL.1.04 EN

SCHILD1896.COM