

Set Up Instructions

WaveLine Media 2000A Panel

Step 1: Assemble straight poles by pressing and pushing together.

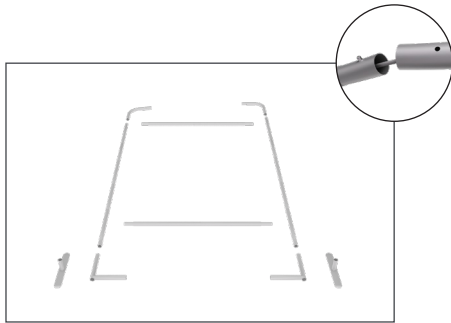

Step 2: Connect all corner sections to curved and straight sections of the frame by matching shape symbols on pipes.

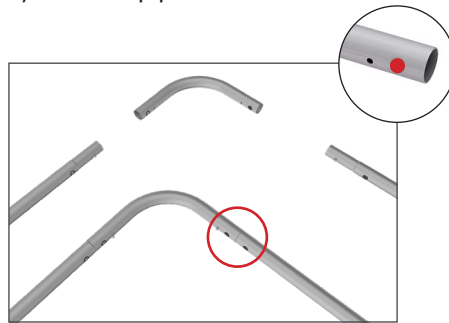

Step 3: Insert feet into base to complete assembled frame shown.

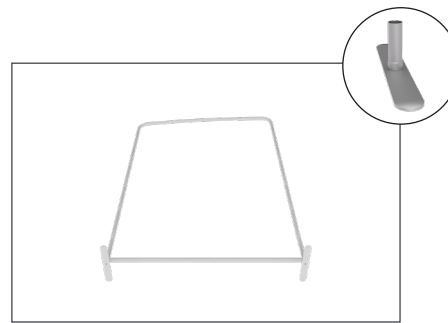

Step 4: Unzip print and lay image face up. Slide print onto frame like a pillow case.

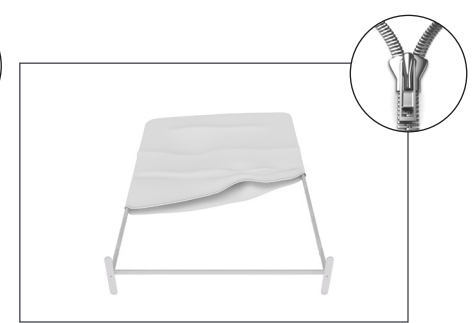

Step 5: Zip the edge of graphic beyond the center point as shown to hold the center pole in place. Zip the remaining side and bottom to meet at the corner.

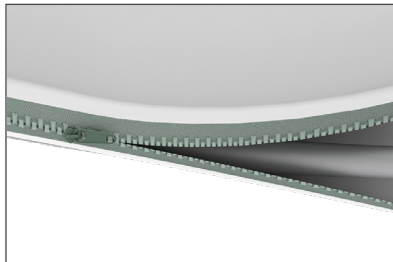

Step 6: Complete.



LIGHTS:
(OPTIONAL) Position as desired and tighten knob to hold in place.
WARNING! Over tightening may cause damage to fabric image.

Set Up Instructions

WaveLine Media Panel Connection

FEET

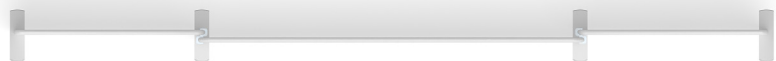
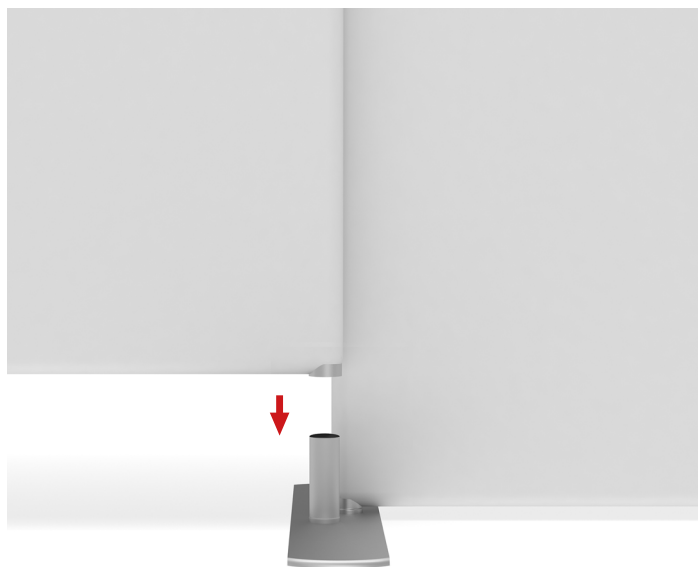

WLM-P-22E



WLM-P-22R



WLM-P-22L



WLM-P-22E

CLAMPS

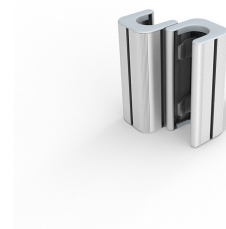
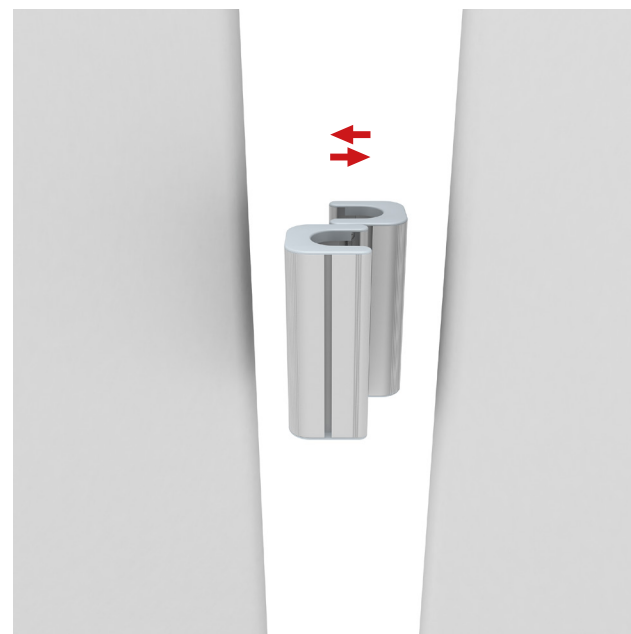

Set Up Instructions

CA500 CASE TO COUNTER

Step 1: Put case flat on the floor and undo straps.

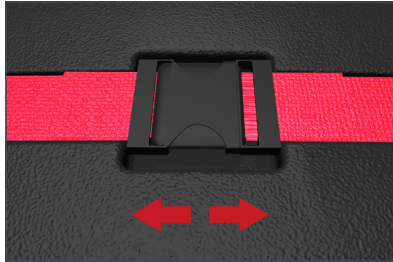

Step 2: Lift lid and remove the contents of the case.



Step 3: Put the lid (not the side with wheels) on the floor first. Place the supplied vertical support poles firmly into place.



Step 4: Now lift the base and place on top of the support pole, fit the poles same as the base.



Step 5: Place case in a clean area to fit the fabric print, like putting your pants on, start at the base, make sure zipper is in the middle.



Step 6: Make sure that all wrinkles are out and the fabric looks straight. Put the lid right on top and press to secure.



Step 7: Complete.

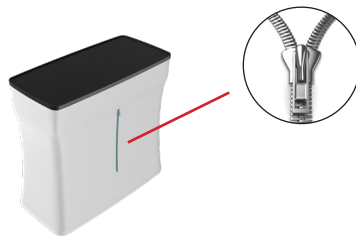

STORAGE:
The zipper on the back is used to access storage.