

# Vector Frame Counter 05

Vector Frame counters compliment the Vector Frame series of exhibit kits, but are also ideal for any stand-alone event or display. Vector Frame counters couple simple extrusion-based frames with flexible rigid PVC graphics. Tables are available in four colored finishes. Custom sizes also available.



## features and benefits:

- Features flexible Sintra graphics and simple extrusion based frames
- Locking door
- Choose from four tabletop finishes
- Easy step-by-step instructions

- Includes a molded portable shipping case
- Lifetime limited warranty against manufacturer defects

## dimensions:

Hardware

Graphic

Assembled unit:  
39.76" w x 40.5" h x 22.75" d  
1010mm(w) x 1029mm(h) x 578mm(d)

Approximate weight:  
59 lbs / 27 kg

Refer to related graphic template for more information.

Visit:  
<https://www.tradeshowplus.com>

Shipping

## additional information:

Packing case(s):  
1 OCH2

Shipping dimensions:  
OCH2:  
52" l x 29" h x 15" d  
1321mm(l) x 737mm(h) x 381mm(d)

Approximate total shipping weight:  
89 lbs / 41 kg

Graphic material:  
Rigid Sintra graphics

When included in a larger kit, a different packaging solution will be listed to accommodate all contents of the kit. Individual packaging no longer provided.

### Tabletop Colors:



silver



black



mahogany



natural



This product may include the following materials for recycle:

aluminum, select wood, fabric, cardboard, paper, steel, and plastics.

We are continually improving and modifying our product range and reserve the right to vary the specifications without prior notice. All dimensions and weights quoted are approximate and we accept no responsibility for variance. E&OE. See Graphic Templates for graphic bleed specifications.

# Included In Your Kit

Tools, Components, & Connectors



HEX KEY SET x1



PH-2R-L-L-IN x2



PH-250-S-S x4



PM2R8-1000 x4



CAM LOCK 2010 x4



VFC-05-CT x1



VFC-05-INT-SHLF x1

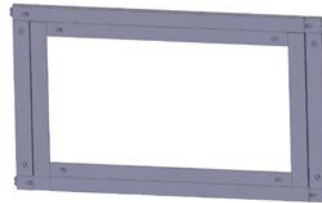

VFC-05-DR x1

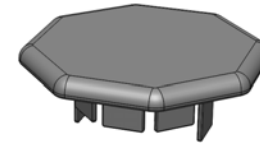

PM2R8-MCAP x4

Graphics



VFC-05-A-G x1



VFC-05-B-G x1



VFC-05-C-G x1



VFC-05-D-G x1

# Exploded View

VFC-05

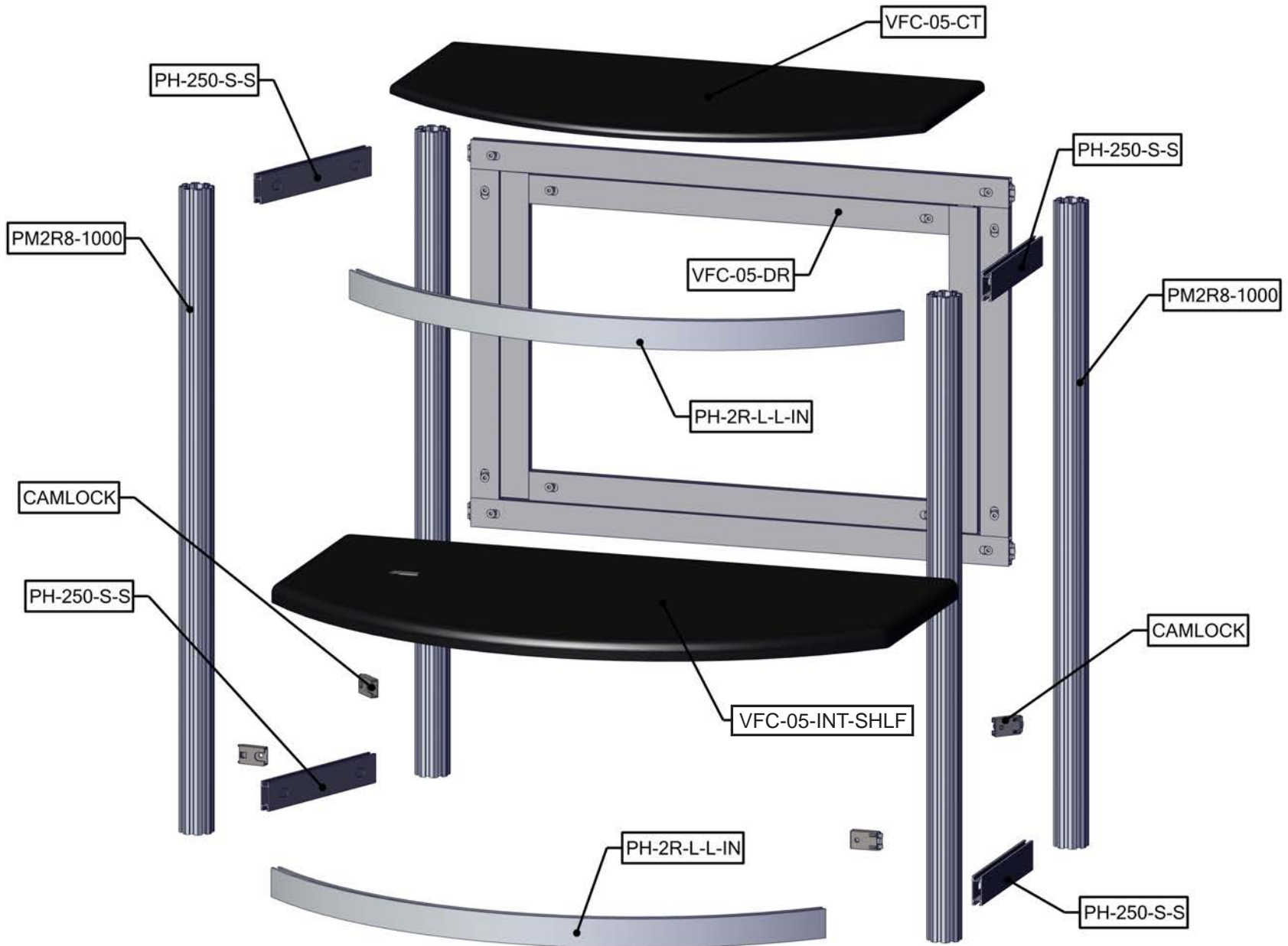

# Kit Assembly

## Step by Step

### Step 1.

Locate (2) PM2R8-1000 and (1) VFC-05-DR. Lock the door to the PM2R8-1000s so that the top of the door assembly is flush with the top of your PM2R8-1000s.

Please reference Connection Method 1 for more details.

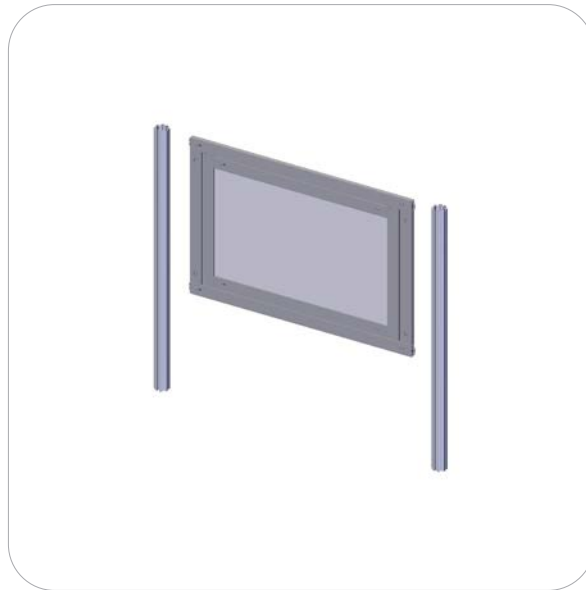

### Step 2.

Gather (2) PM2R8-1000 extrusions and (1) PH-2R-L-L-IN. Lock together so that the top of the upper PH-2R-L-L-IN is flush with the top of the PM2R8-1000s.

Please reference Connection Method 1 for more details.

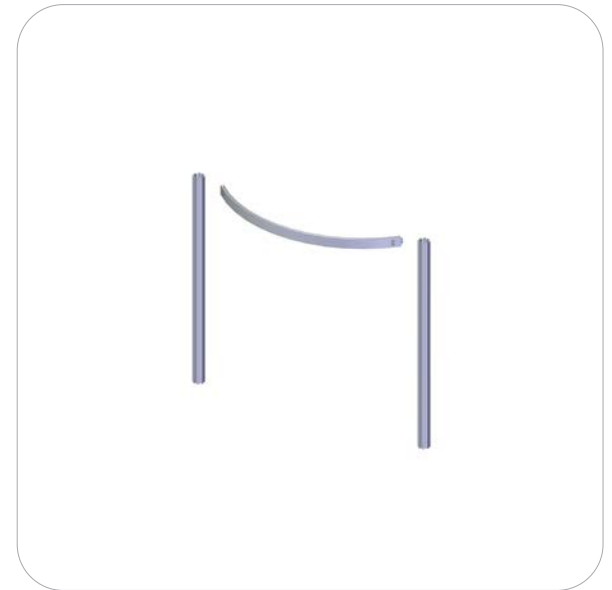

### Step 3.

Combine Step 1 and Step 2 assemblies by adding (2) PH-250-S-S. Remember to lock the extrusions with the lock holes facing into the cabinet.

Please reference Connection Method 1 for more details.

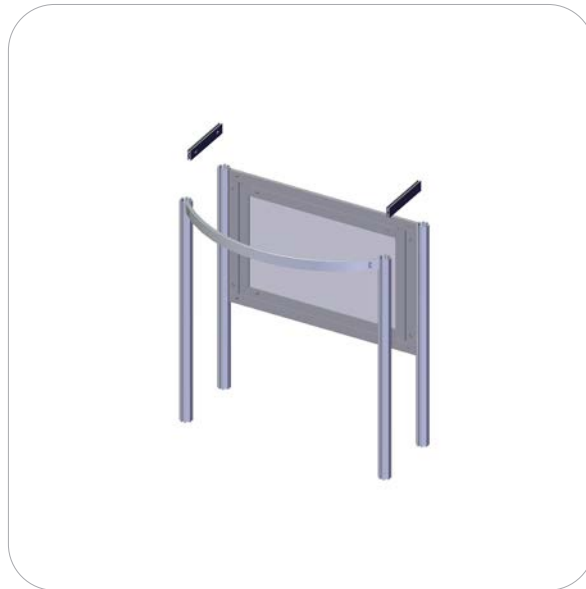

### Step 4.

Locate (4) CAM LOCKS. Lock each CAM LOCK into the corners of your VFC-05 assembly. Measure so that the bottom of the CAM LOCKS are flush to the bottom of the door assembly.

Please reference Connection Method 1 for more details.

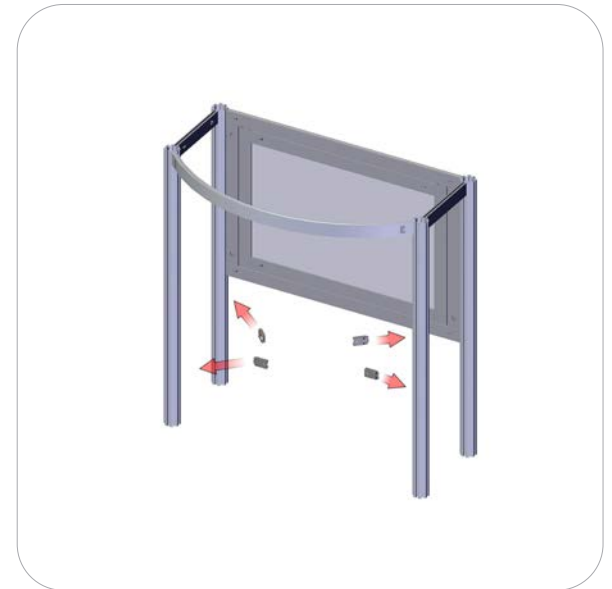

# Kit Assembly

## Step by Step

### Step 5.

Apply your VFC-05-INT-SHLF internal shelf. Allow the shelf to rest on the installed CAM LOCKS.



### Step 6.

Slide your graphics up the sides of the cabinet until they rest against the top extrusions.

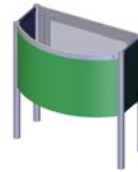

### Step 7.

Add your second layer of extrusions to the bottom of the graphics to keep them in place.

Please reference Connection Method 1 for more details.

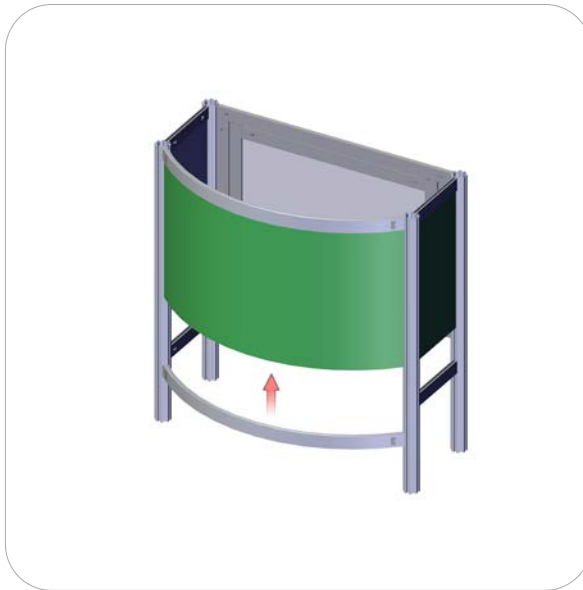
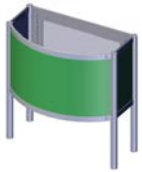

### Step 8.

Place your VFC-05-CT on top of your unit. Add the remaining plastic caps to the bottom of each extrusion touching the ground.

Setup is complete.



# Connection Methods

## Connection Method 1: CAM LOCK

---



First, with the cam lock disengaged, place the cam lock teeth into the extrusion channel. Second, use the allen key tool to lock it in place. Make half turns clock-wise to engage the cam lock. Do not over tighten the lock buttons.

---