

Vector Frame Counter 03

Vector Frame counters compliment the Vector Frame series of exhibit kits, but are also ideal for any stand-alone event or display. Vector Frame counters couple simple extrusion-based frames with push-fit graphics. Countertops are available in four colored finishes. Custom sizes also available.

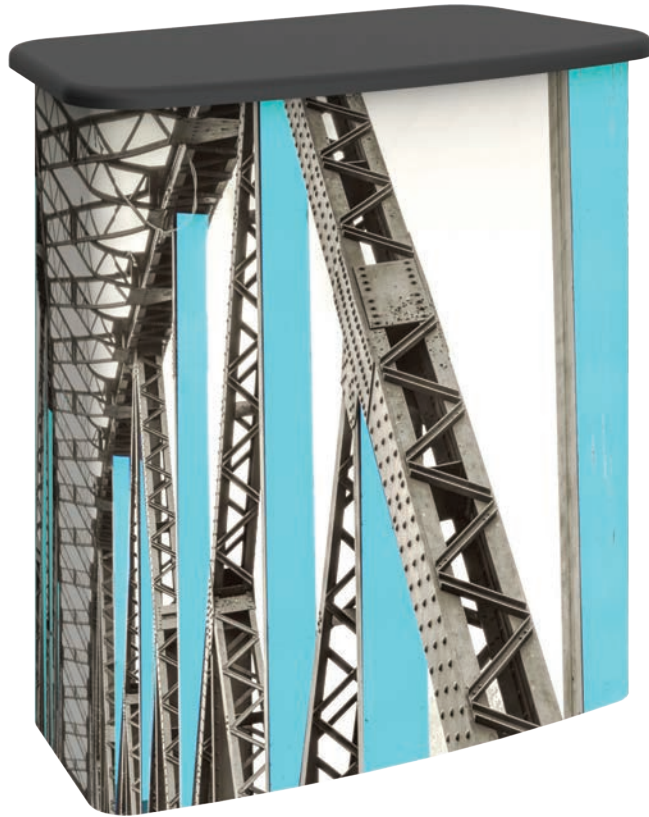

features and benefits:

- Feature push-fit fabric graphics and simple extrusion based frames
- Choose from four countertop finishes
- Easy step-by-step instructions
- Allow for extra storage by removing one fabric panel
- Lifetime limited warranty against manufacturer defects

dimensions:

Hardware

Assembled unit:
38.5" w x 40.5" h x 19.88" d
978mm(w) x 1029mm(h) x 504.952mm(d)

Approximate weight:
54 lbs / 25 kg

Graphic

Refer to related graphic template for more information.

Visit:
<https://www.tradeshowplus.com>

Shipping

Packing case(s):
1 OCH2

OCH2:
52" l x 29" h x 15" d
1321mm(l) x 737mm(h) x 381mm(d)

Approximate total shipping weight:
84 lbs / 39 kg

additional information:

Graphic material:
Dye-sublimation SEG push-fit fabric

When included in a larger kit, a different packaging solution will be listed to accommodate all contents of the kit. Individual packaging no longer provided.

Counter holds max weight:
100 lbs / 46 kg

Panel Colors:



Tabletop Colors:

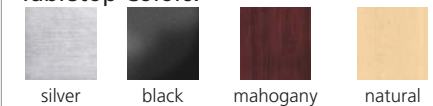

This product may include the following materials for recycle:
aluminum, select wood, fabric, cardboard, paper, steel, and plastics.

We are continually improving and modifying our product range and reserve the right to vary the specifications without prior notice. All dimensions and weights quoted are approximate and we accept no responsibility for variance. E&OE. See Graphic Templates for graphic bleed specifications.

Included In Your Kit

Tools, Components, & Connectors



5MM ALLEN-T x1

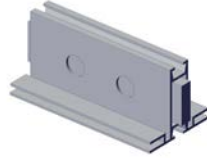

PHFC2-100-L-L x4

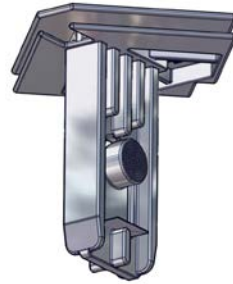

PMFC2-90-CP x4



PMFC2-90-986-L1-L1 x2



PHFC2-300-L-L x4



PHFC2-8R-20-L-L x2



PH1-288-L-L x4



PE-1000 x2

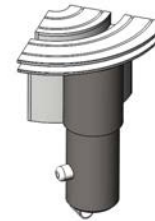

CB10-R x8



VFC-03-CT x1



VFC-03-INT-SHLF x1



TUBE-30-910 x4

Graphics



VFC-03-A-G x1



VFC-03-B-G x1

Exploded View

VFC-03
Section 1

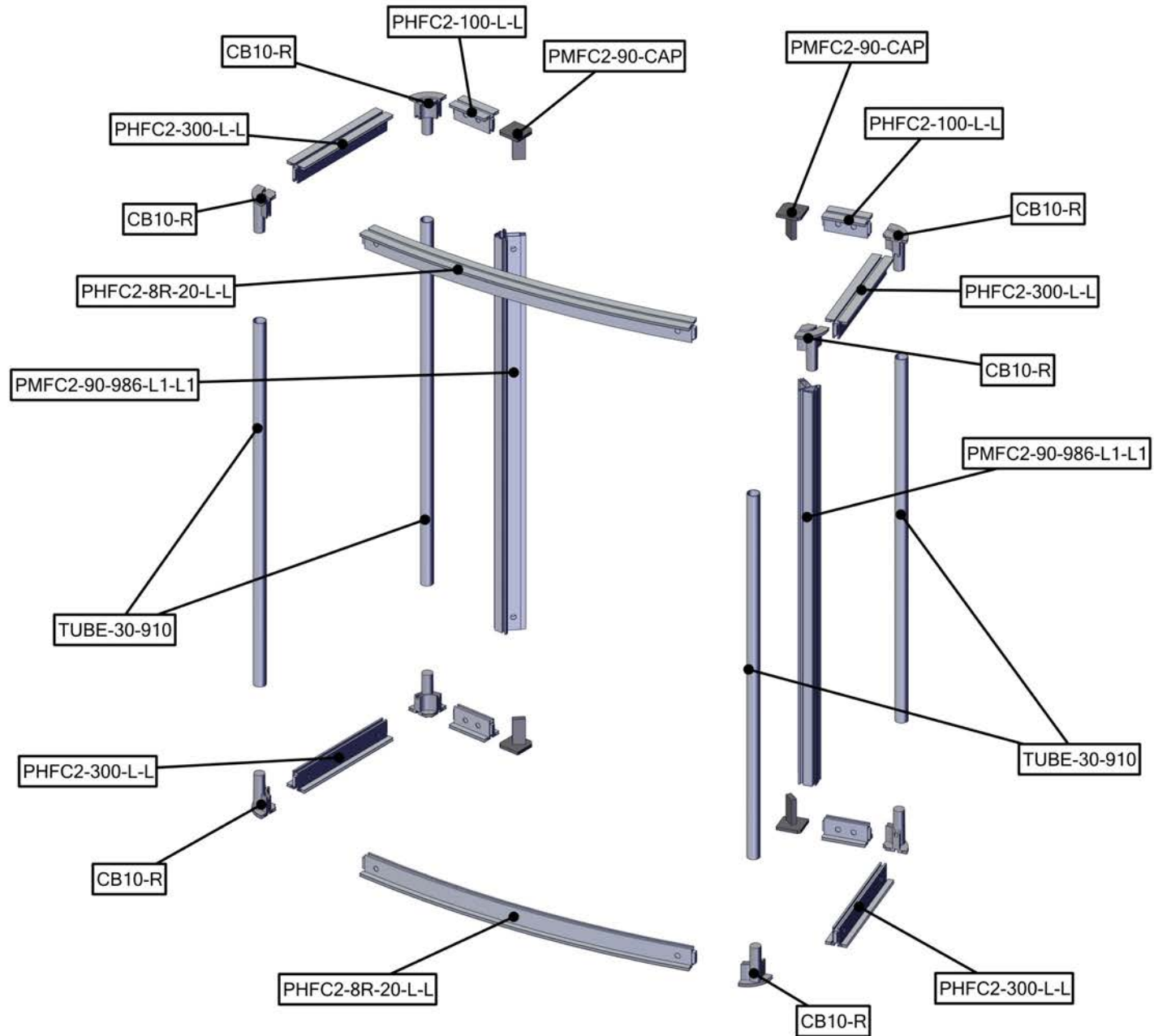

Exploded View

VFC-03
Section 2

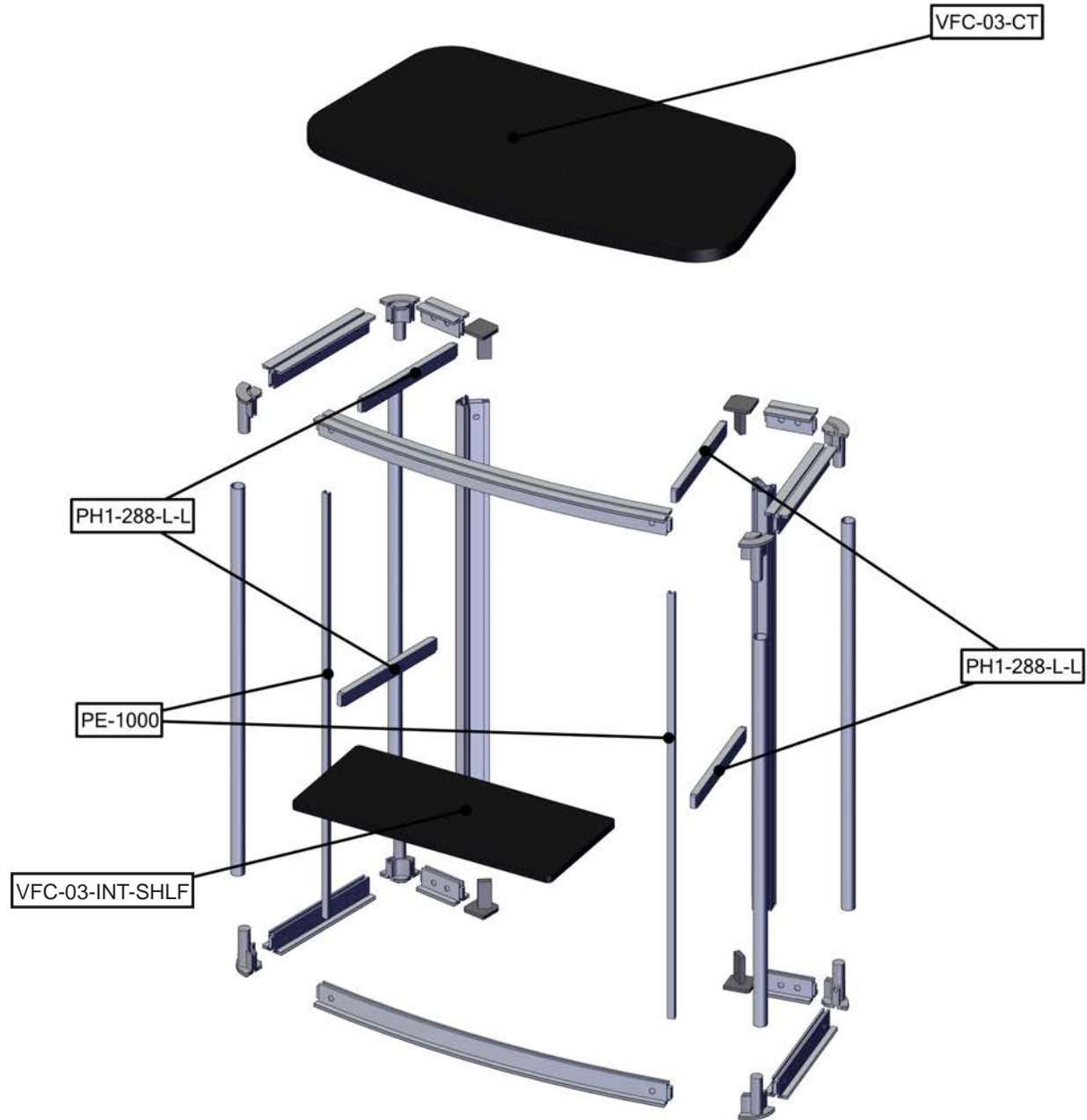

Kit Assembly

Step by Step

Step 1.

Gather the components to build the frame. Use the Exploded View for part labels.

Reference Connection Method(s) 1 & 2 for more details.



Step 2.

Install the framework for the interior shelf and then set the shelf on top of it.

Reference Connection Method 2 for more details.

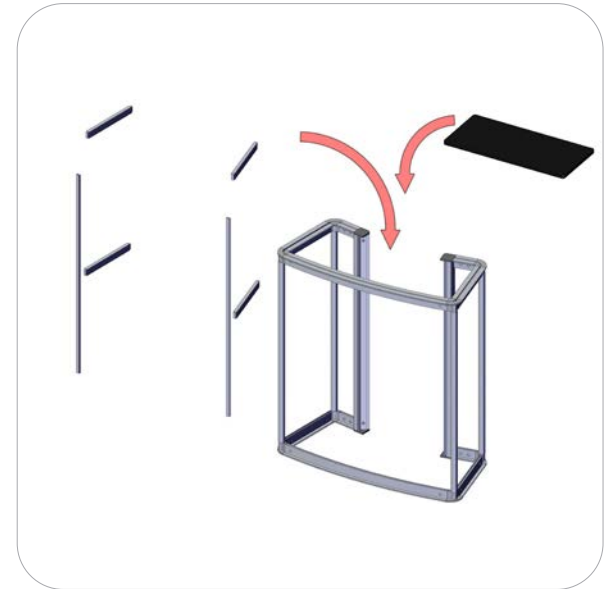

Step 3.

Attach the graphics to the frame.

Reference Connection Method 3 for more details.

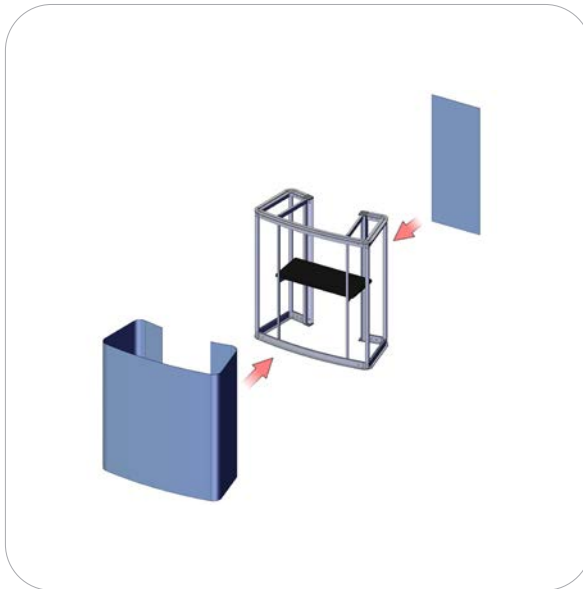

Step 4.

Place the countertop onto the completed frame.

Setup is complete.



Connection Methods

Connection Method 1: PMFC2-90-CAP



First, press button to insert the cap into the extrusion. The button will snap in place.

Connection Method 2: PMFC2 / PHFC2



First, with the cam lock disengaged, place the cam lock teeth into the extrusion channel. Second, use the allen key tool to lock it in place. Make half turns clock-wise to engage the cam lock. Do not over tighten the lock buttons.

Connection Method 3: Graphic Application

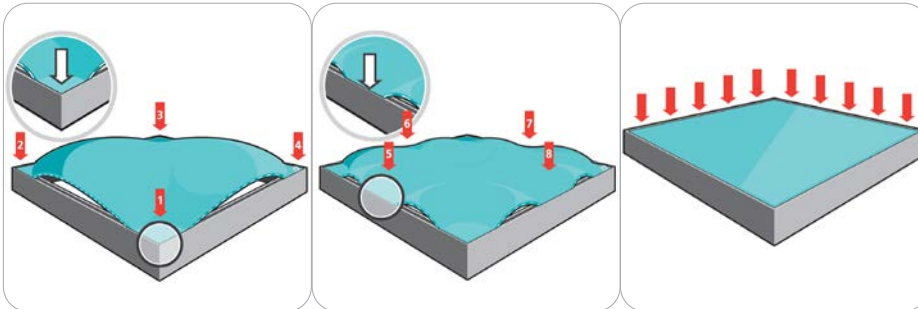

First, insert the silicone edge frame corners into the frame graphic channel (points 1 through 4).
Second, insert the silicone edge frame sides into the frame graphic channel (points 5 through 8).
Third, push the remaining silicone edge fabric into the frame graphic channel.
Similar setup is recommended for the opaque liner.
To remove these panels, simply pull the loop tag sewn near a corner.