

POP UP DISPLAYS

ONE CHOICE - 8 FT. FABRIC
POP UP DISPLAY (NO ENDCAPS)



Front View



Angle View

PRODUCT DESCRIPTION

The Fabric Pop Up is the perfect display on the go and is ready in minutes. The lightweight aluminum alloy frame locks in place using plastic hooks. Attach the graphic to the frame with hook and loop fasteners. Interchangeable graphics make it a versatile choice. Easily collapse the frame with front graphic attached and stow in your carry bag.

FEATURES

DISPLAY DIMENSIONS

- 89" W x 89" H x 12" D

GRAPHIC DIMENSIONS

- 87.75" W x 88.5" H

GRAPHIC MATERIAL

- Stretch Fabric

GRAPHIC FINISHING

- 2" Loop on back perimeter

DISPLAY CONSTRUCTION

- Aluminum frame
- 2" Hook
- Plastic hooks

WEIGHTS & DIMENSIONS (WITH STAND & GRAPHICS)

SHIPPING WEIGHTS

- (Qty 1): 24 lbs
- (Qty 13): 375 lbs

PACKAGE DIMENSIONS

- (Single Box):
12" L x 12" W x 33" H
- (Freight):
48" L x 40" W x 64" H skid

TURNAROUND TIME

GRAPHIC PACKAGE

- 4 business days after proof approval*

AVAILABILITY

- WEST COAST FULFILLMENT CENTER

*After proof approval, for up to 10 sets.



POP UP DISPLAYS

ONE CHOICE - 8 FT. FABRIC
POP UP DISPLAY



PARTS LIST



QTY 1:
Black Nylon Carry Bag

Outside Dimensions:

- 32" L x 12" W x 14" H

Inside Dimensions:

- 31 3/8" L x 11" W x 14" H



QTY 1:
Frame w/ Pre-Installed Graphic

- 9 1/4" L x 10 3/4" W x 31 1/4" H
(Collapse Frame)

POP UP DISPLAYS

ONE CHOICE - 8 FT. FABRIC
POP UP DISPLAY (NO ENDCAPS)



INSTRUCTIONS

1

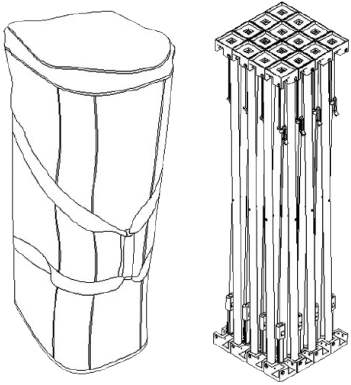

- Remove frame from bag.

2

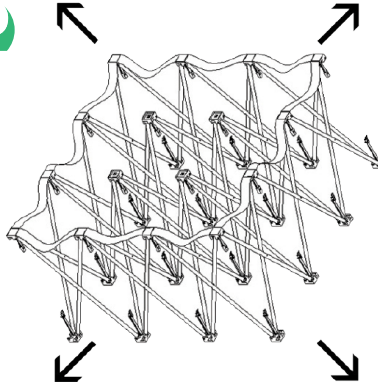

- Expand frame by pulling outward.

3

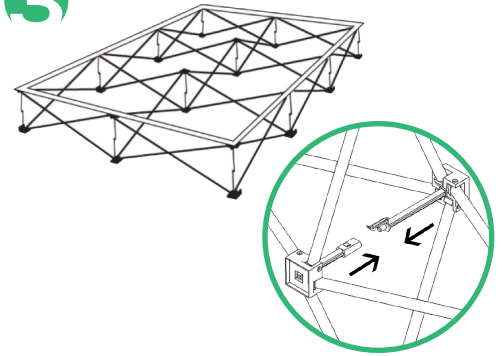

- Make sure hook strips are facing up. Push together all locks on frame to connect.

4

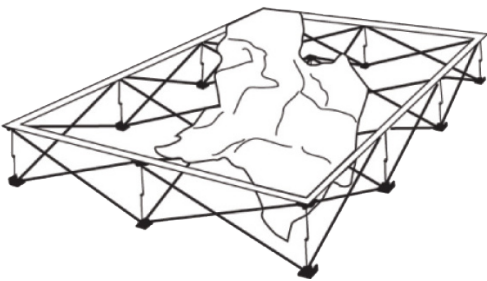

- Starting at one corner, attach loop on the graphic to hook on the frame.

5

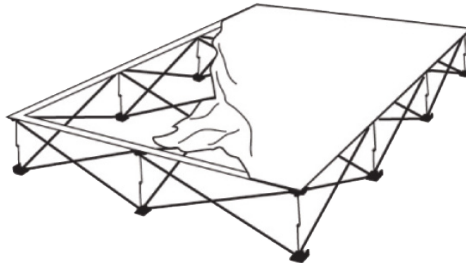

- Attach the rest of the graphic by working your way around the frame. Make sure graphic is pulled taut while attaching the hook and loop.

6



- If needed, adjust graphic for maximum tautness. Complete installation.

POP UP DISPLAYS

ONE CHOICE - 8 FT. FABRIC
POP UP DISPLAY



CARE SHEET - DYE-SUB FABRIC

HANDLING TIPS

1. If your exhibit fabric has a zipper, please keep zipper closed for storage.
2. Wrinkles can be removed with cool iron or fabric steamer.
3. Fabric should NOT be stored when damp or wet. Store in cool, dry area.
4. For storing graphics please remove from plastic packaging that was provided and keep fabric in cool/dry place.

WASHING

1. Your fabric graphic can be machine washed. Remove any hardware attached to the fabric prior to cleaning. Use MILD soap and cool water. Air dry fabric, dry on frame if frame is available.
2. Fabric must be COMPLETELY dry prior to storing.
3. DO NOT DRY CLEAN

STAIN TREATMENT

1. Treat stain from backside of fabric.
2. Remove as much debris as possible with a soft bristle brush (do NOT rub too hard).
3. Use a clean, lint-free white cloth. Lightly pat the stain from the outside moving in (to keep stain from spreading).
4. If a cleaning solution is used, rinse the area well with water to ensure NO solution is left on fabric.
5. Most stains can be treated with household fabric stain removers. It is ALWAYS important to test how the solution will react to the fabric. This can be tested by dabbing solution to a small corner of the fabric. Most household cleaners will provide treatment instructions depending on the type of stain.



- Wrinkles can be removed from fabric with a cool iron or steamer.



- Fabric can be machine washed - use cold water, delicate cycle.



- Do NOT bleach fabric



- Do NOT tumble dry. Fabric must be air dried on the frame to prevent shrinking.