

# Hybrid Pro Modular Display 23

Hybrid Pro Modular Kit 23 is a sophisticated and symmetrical 20ft x 20ft island exhibit, perfect for an exhibitor looking for features and functionality. Kit 23 features a heavy-duty aluminum extrusion center frame that supports two square-shaped fabric structures.

The top fabric structure is a tube structure with pillowcase fabric graphics and is meant to display your company logo so all in the exhibit hall can see it from afar! The center square utilizes the extrusion posts to create an additional area for branding and messaging above eye-level. Two 8ft tall floor displays add features and functionality. With medium monitor mounts and three shelves for small product display on each, the floor-based displays are designed to show and communicate your service offering in digital form and your product in physical form. Counters near the center posts add areas for storage and reception.

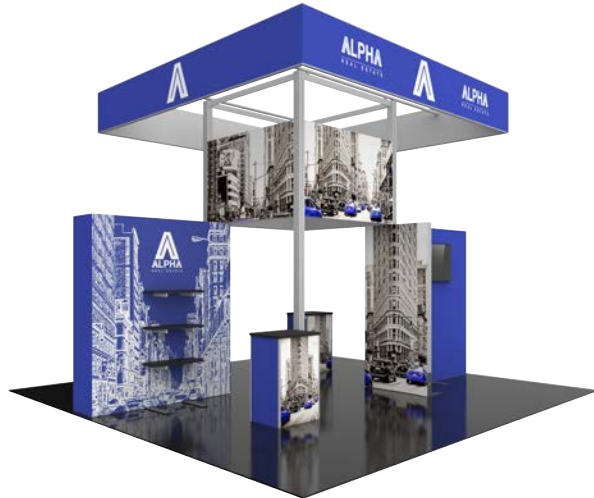

## features and benefits:

- 14'4" tall island display
- No rigging required
- Features two square fabric structures up high to draw visitors to the booth
- Floor based backwalls feature push-fit f
- Center counters add storage and reception areas
- Ships freight in a woodcrate
- Medium monitor bracket on center wall holds 32-55" LCD\*, max weight: 80 lbs
- \*Monitors & flooring are not included

## dimensions:

### Hardware

Assembled unit:  
244.33"w x 171.5"h x 168"d  
6206mm(w) x 4357mm(h) x 4268mm(d)

Approximate weight: 1130 lbs / 513 kg

### Graphic

Refer to related graphic template for more information.

Visit:  
<https://www.tradeshowplus.com>

### Shipping

Packing case(s): WOODCRATE-V

Shipping dimensions:  
48"l x 101"h x 53"d  
1220mm(l) x 2566mm(h) x 1347mm(d)

Approximate total shipping weight:  
1440 lbs / 654 kg

## additional information:

Graphic material:

Dye-sublimation SEG push-fit fabric

When included in a larger kit, a different packaging solution will be listed to accommodate all contents of the kit. Individual packaging no longer provided.

### Tabletop Colors:

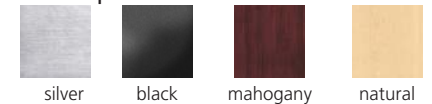

3 person assembly recommended:



This product may include the following materials for recycle:  
aluminum, select wood, fabric, cardboard, paper, steel, and plastics.

We are continually improving and modifying our product range and reserve the right to vary the specifications without prior notice. All dimensions and weights quoted are approximate and we accept no responsibility for variance. E&OE. See Graphic Templates for graphic bleed specifications.

# Included In Your Kit

Tools, Components, & Connectors



ALLEN KEY 5MM x1



CB9 x24



IB2 x4

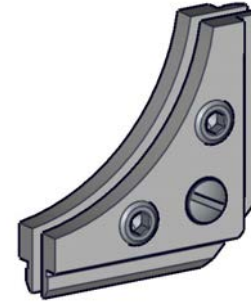

CBE-50 x58

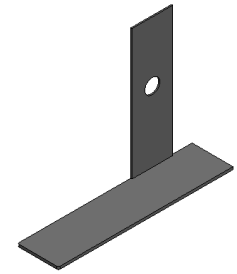

SW-FOOT-650-LN x2



BP-LN114-S2-650 x4

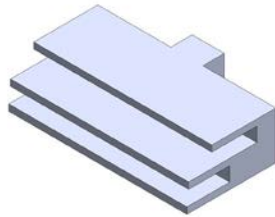

FC-50-SPACER x16



PMFC4-90-1193-A315 x16

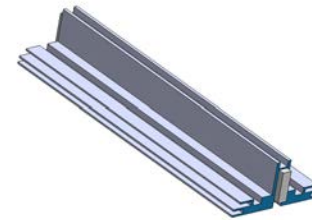

PHFC4-300-L-L x4



PHFC4-600-MCB9-MCB9 x4

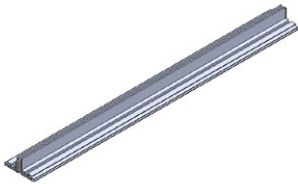

PHFC4-900-L-L x16



PHFC4-1200-L1-MCB9 x4



PHFC4-1200-L1-MCB9-SIDE x4



PH4-300-TG x4



PHFC4-1200-MCB9-MCB9-SIDE x8

# Included In Your Kit

Tools, Components, & Connectors



PHFC4-1800-MCB9-MCB9 x8

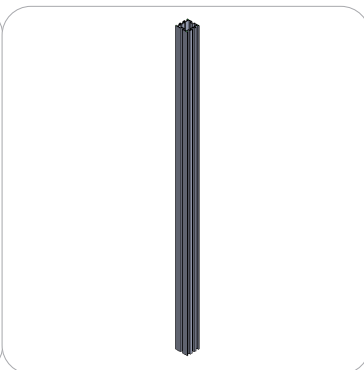

PM2S2-1200-A165-N x8

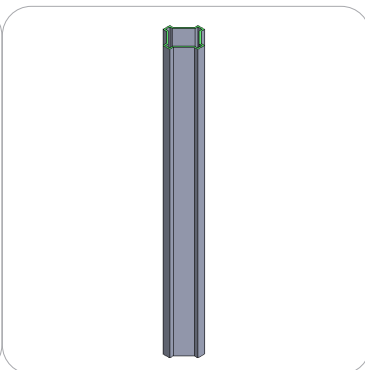

PM4DSC-600 x10

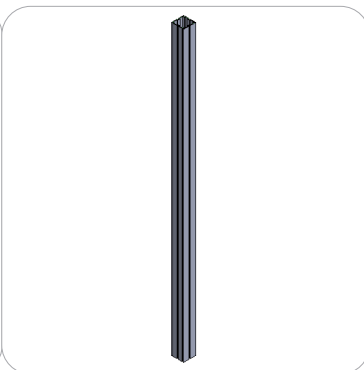

PM4S2-2400-A315-A315 x2

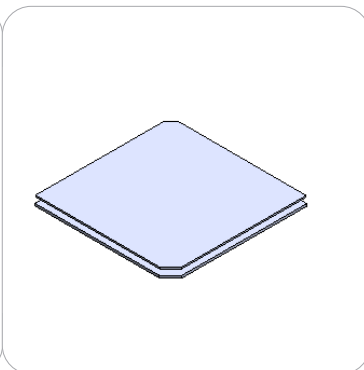

PMFC4-90-CAPx16

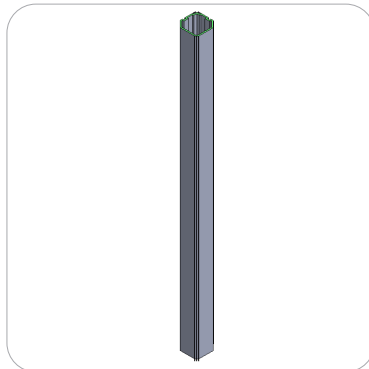

PMFC4-90-1193-A315 x16



PM4S2-1800-A315-A315 x4



PS90-1000 x6

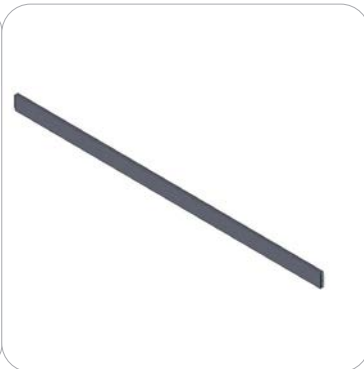

PH2-1800-L-L x4



PT-1000 x2

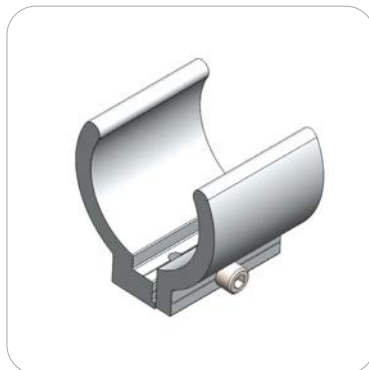

TC-50MM-SILVER x4

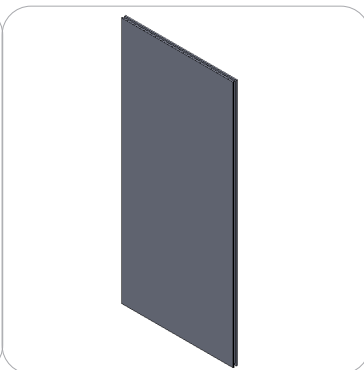

PHFC4-1200-L1-MCB9 x4

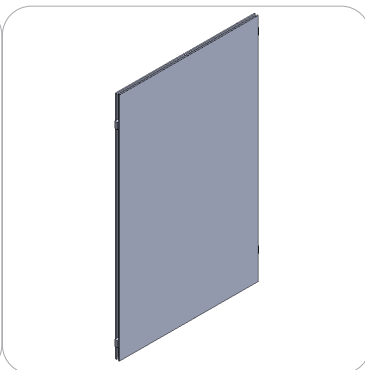

LP-600-1000 x2

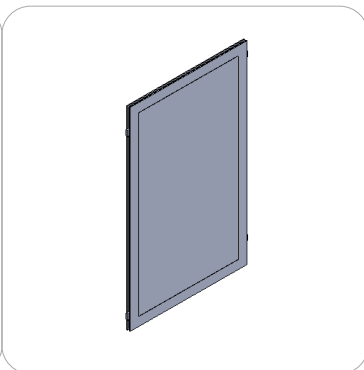

LP-CD-600-1000 x2

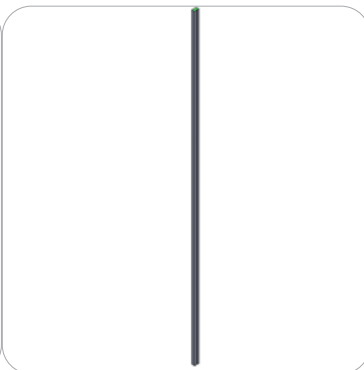

L180N-1000x2

# Included In Your Kit

GRAPHICS

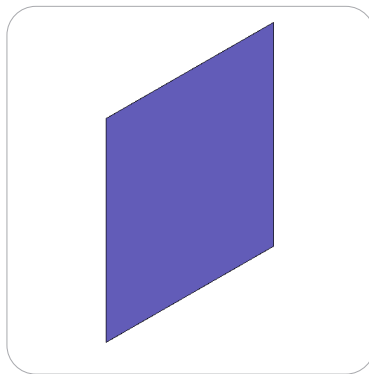

HP-23-A2-G x1



HP-23-A1-G x1

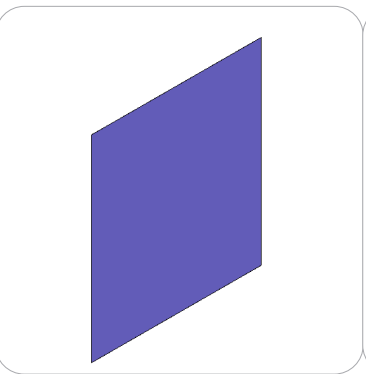

HP-23-A4-G x1

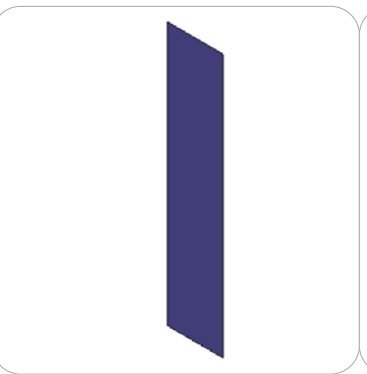

HP-23-A3-G x1

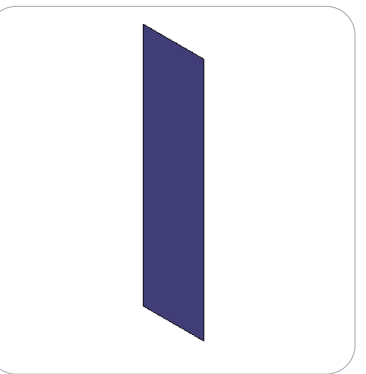

HP-K-23-G-A5 x1

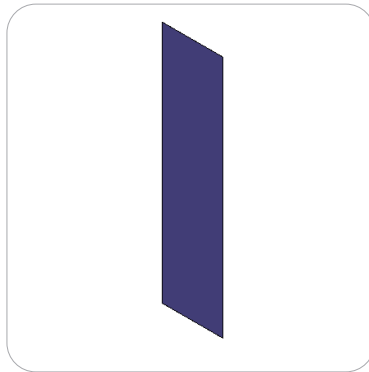

HP-23-A6-G x1

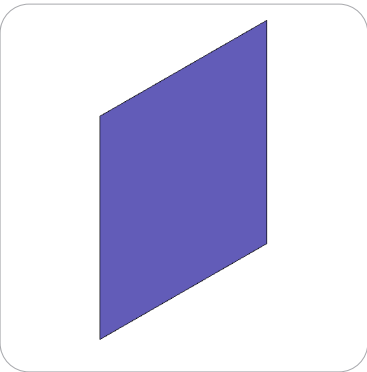

HP-23-B2-G x1



HP-23-B3-G x1

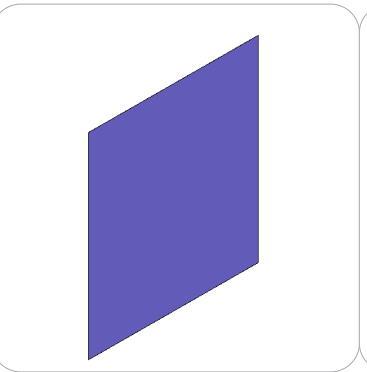

HP-23-B4-G x1



HP-23-B5-G x1

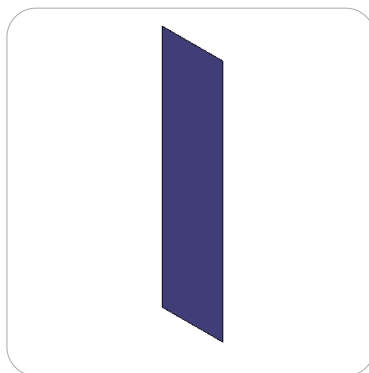

HP-23-B6-G x1

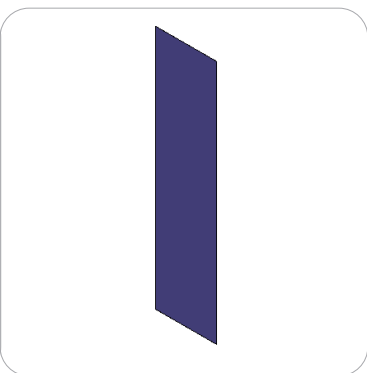

HP-23-B1-G x1

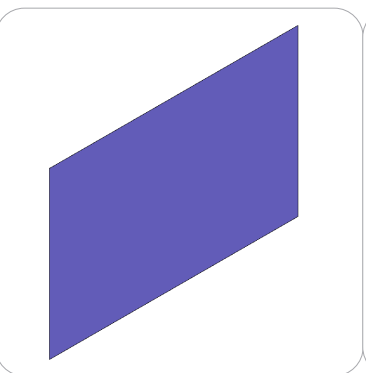

HP-23-D1-G x1

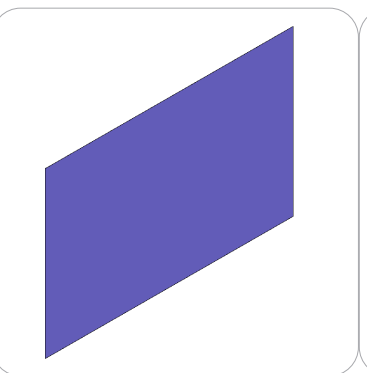

HP-23-D2-G x1

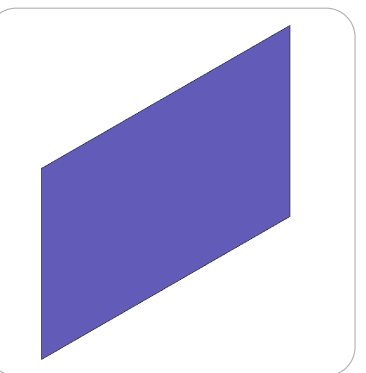

HP-23-D3-G x1

# Included In Your Kit

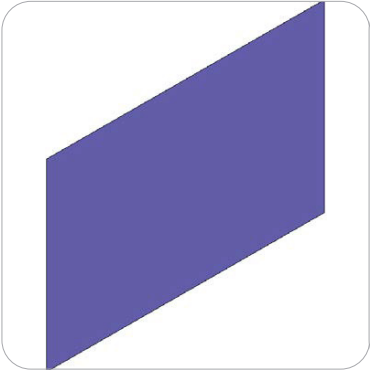

HP-23-D4-G x1

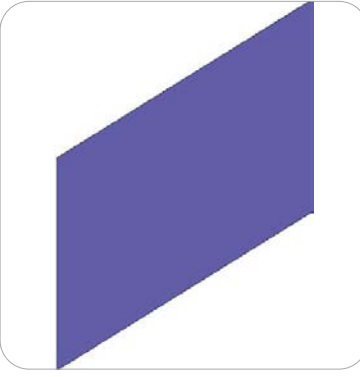

HP-23-C1-G x1

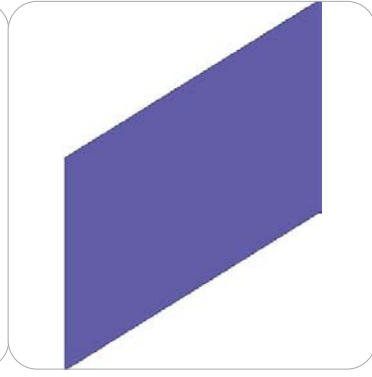

HP-23-C2-G x1

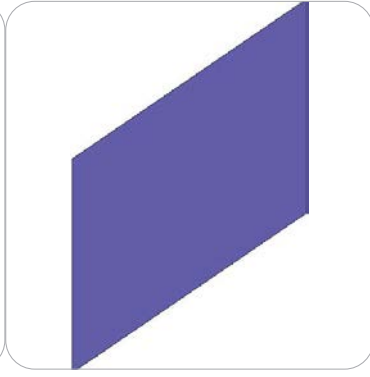

HP-23-C3-G x1

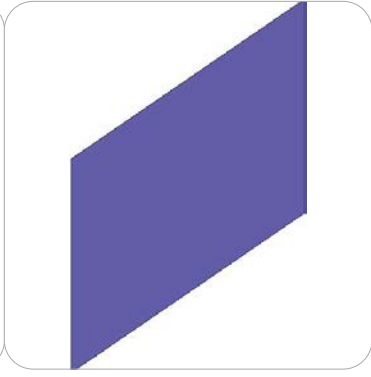

HP-23-C4-G x1

GRAPHICS

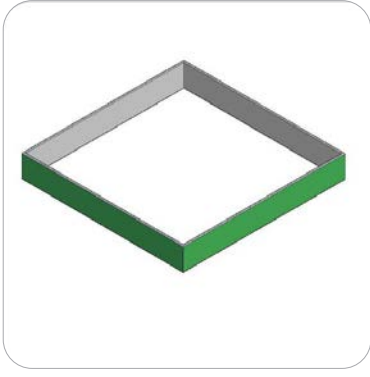

HP-23-A6-G x1

# Included In Your Kit

Tubes & Hardware



SPDR-50-S2-2\_B x4

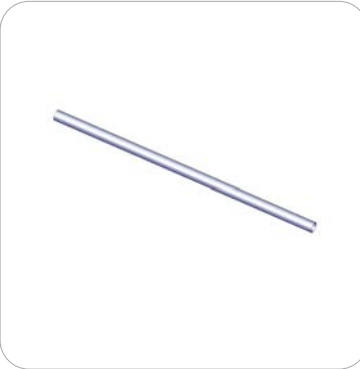

HP-K-SQU-T1 x12



HP-K-23-SQU-T2 x8



HP-K-23-SQU-T3 x2



HP-K-23-SQU-T4 x4



HP-K-23-SQU-T5 x6



ES50 x24



ES50-3W x8



SPDR-30-S2-2 x8

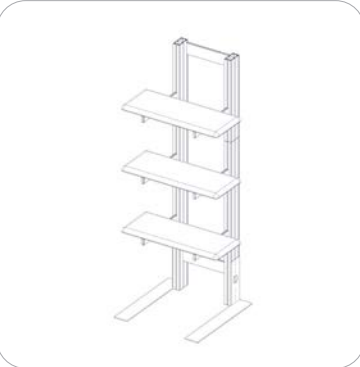

PM4S3-MK-SHELF-UNIT x2

# Exploded Diagram

HP-K-23

## Section 1.4 & 1.5

Reference the Suggested Layout page for build location.

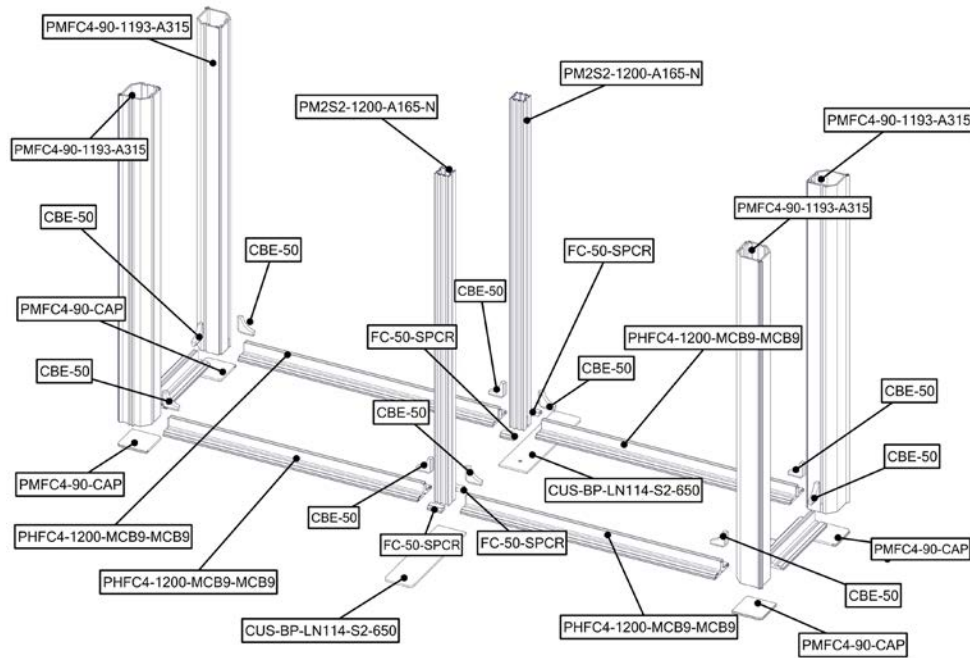

**-ASSEMBLE LOWER FRAME OF TOWER**

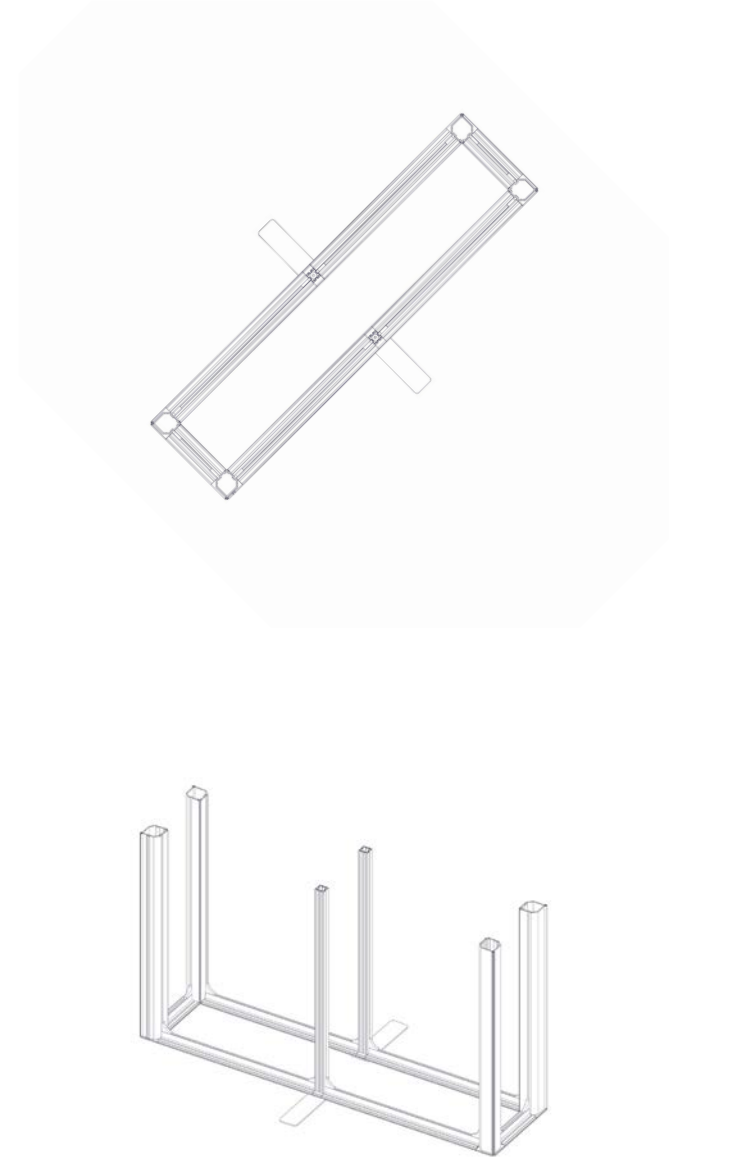

# Exploded Diagram

HP-K-23

Section 1.4 & 1.5

Reference the Suggested Layout page for build location.

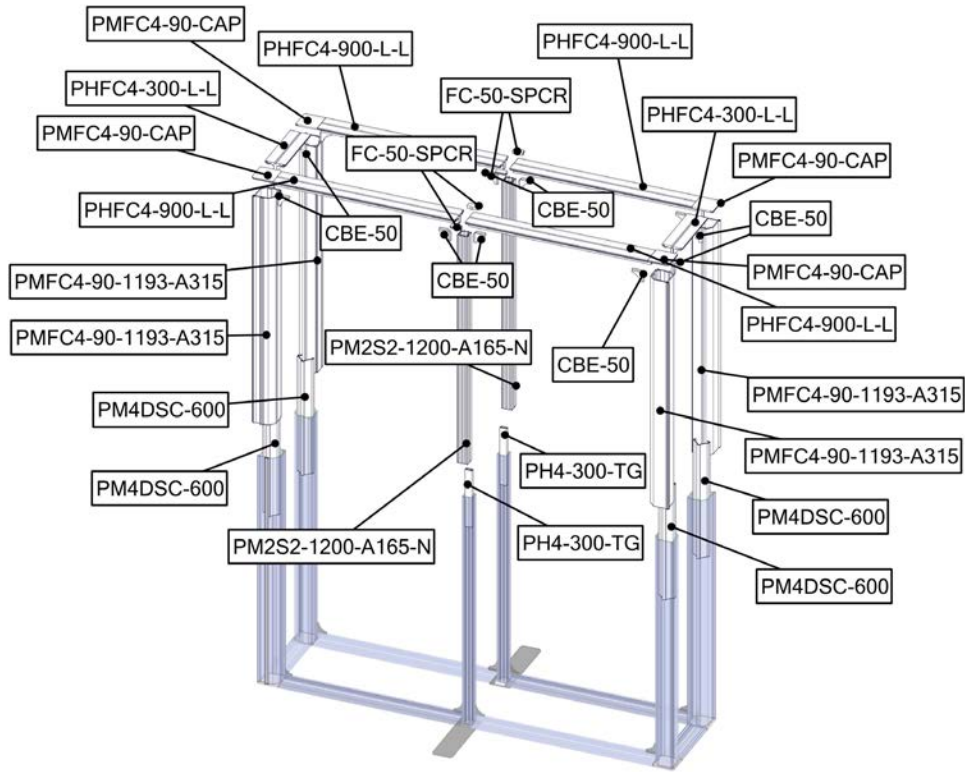

**-ASSEMBLE UPPER FRAME OF TOWER**

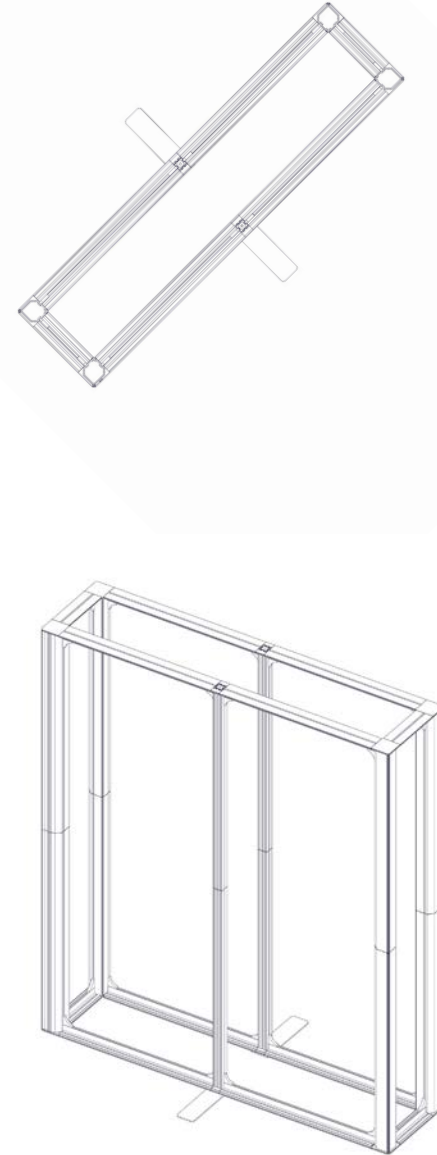



# Exploded Diagram

HP-K-23

**Section 1.4 & 1.5**  
**Reference the Suggested Layout page**  
**for build location.**

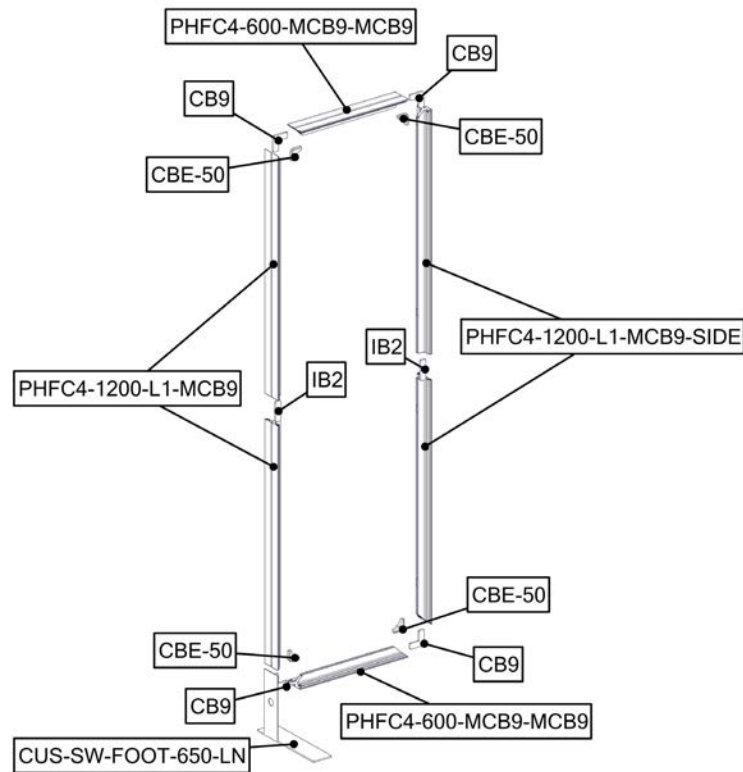

**-ASSEMBLE & ATTACH TO FRAME**

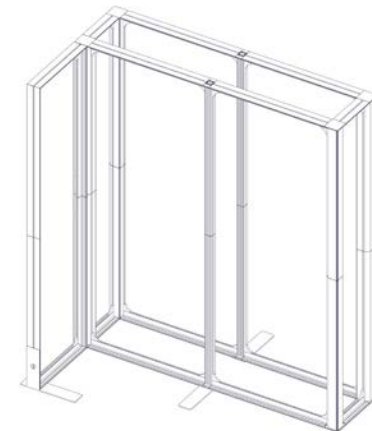
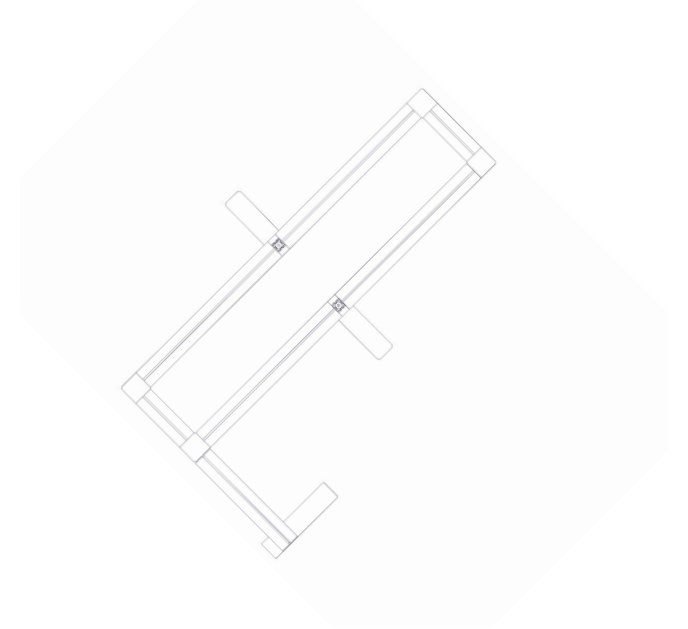

# Exploded Diagram

HP-K-23

**REMOVE SHELVING BEFORE COMPLETING NEXT STEP**

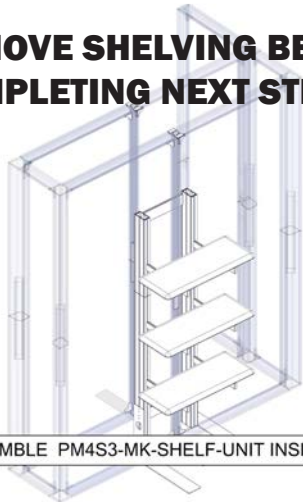

ASSEMBLE PM4S3-MK-SHELF-UNIT INSIDE FRAME

**-STEP 1  
ASSEMBLE PM4S3-MK-SHELF-UNIT**

**LABEL DIAGRAM NEXT PAGE**

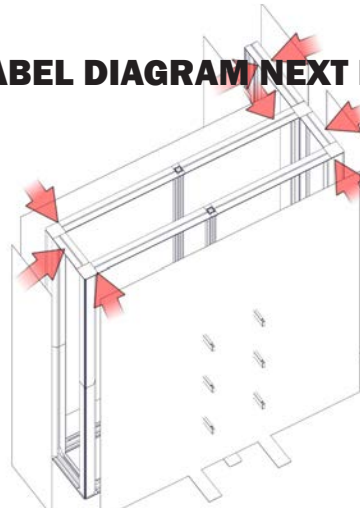

**-STEP 2  
ATTACH GRAPHICS**

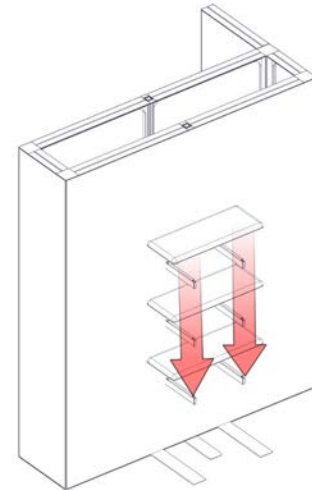

**-STEP 3  
ATTACH SHELVING**

**Section 1.4 & 1.5  
Reference the Suggested Layout page for build location.**

**-ATTACHED DETAILED  
PDF ON ASSEMBLY OF  
PM4S3-MK-SHELF-UNIT**

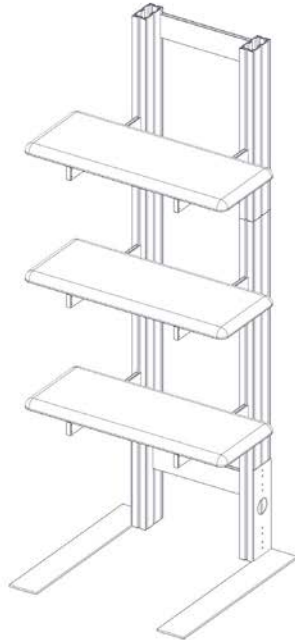

**-PLACEMENT OF PM4S3-MK-SHELF-UNIT**

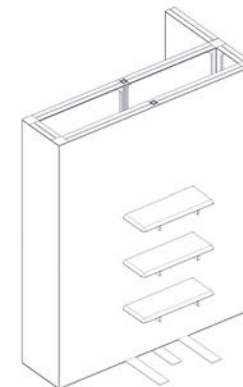

# Labeling Diagram

HP-K-23

Section 1.4 & 1.5

Reference the Suggested Layout page for build location.

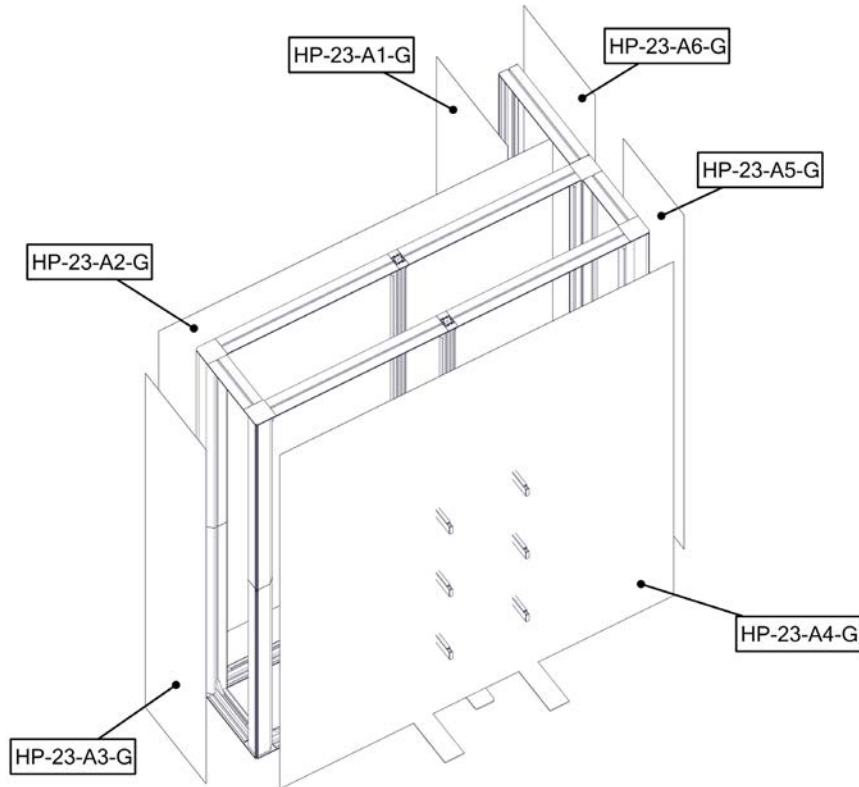

**BOOTH A**

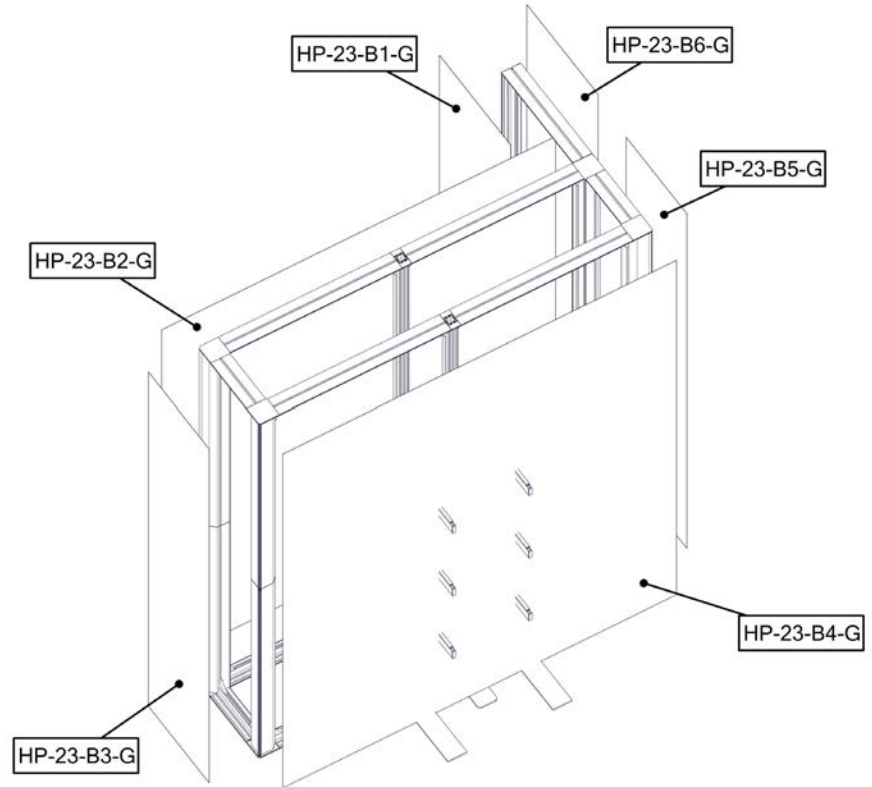

**BOOTH B**

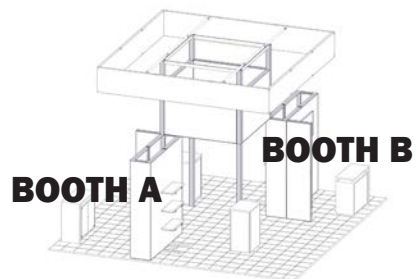

**BOOTH A**

**BOOTH B**

**-GRAPHIC LABEL DIAGRAM**

# Exploded Diagram

HP-K-23

## Section 1.3

Reference the **Suggested Layout** page for build location.

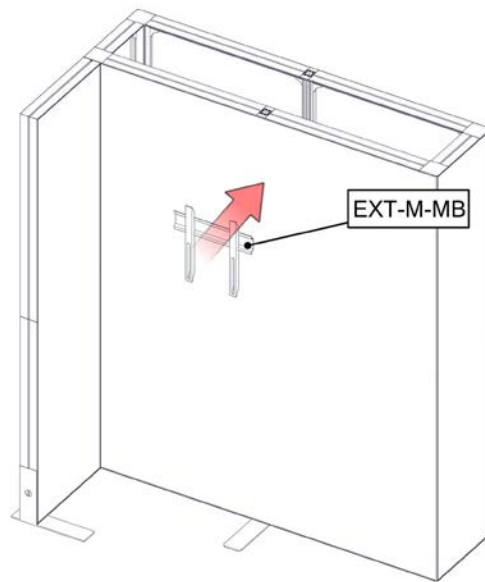

**-ATTACH MONITOR MOUNT TO FRAME**

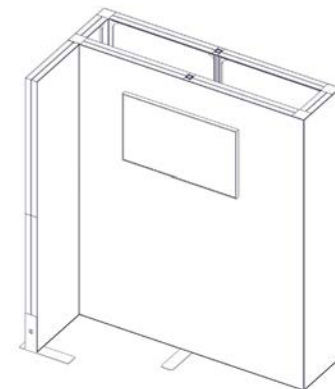
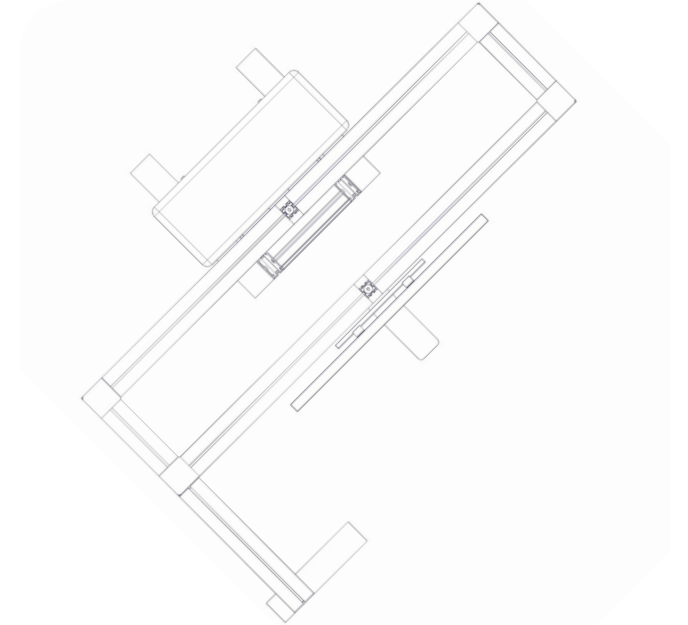

# Exploded Diagram

HP-K-23

## Section 1.1

Reference the Suggested Layout page for build location.

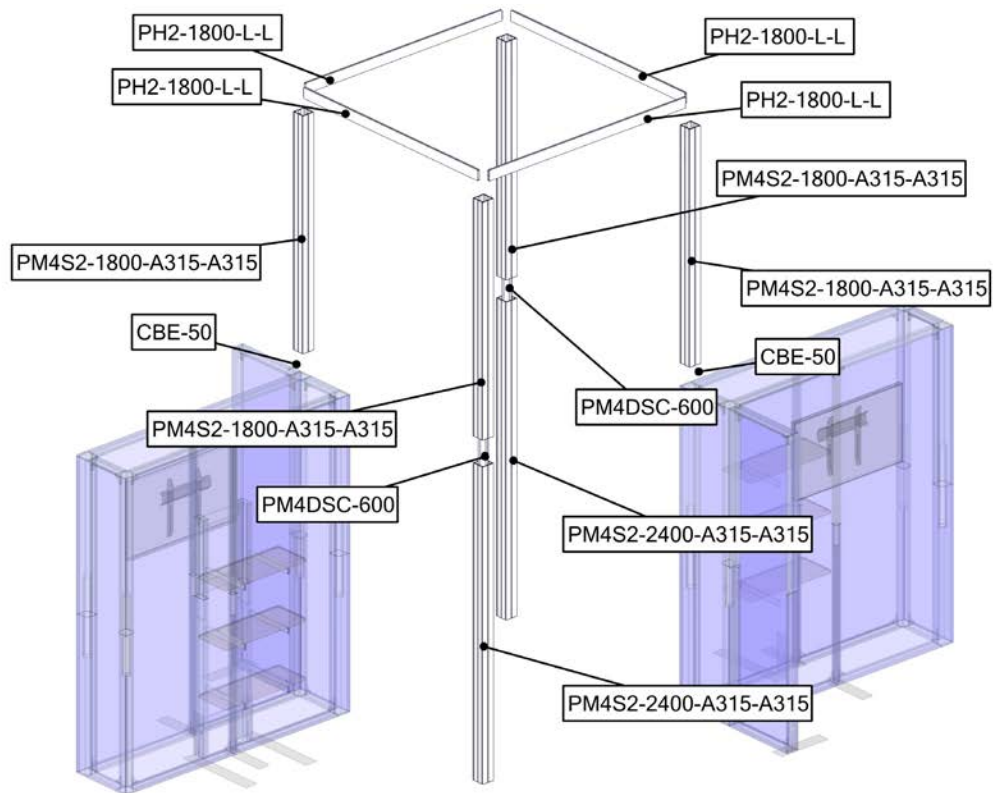

**-ASSEMBLE CENTER TOWER**

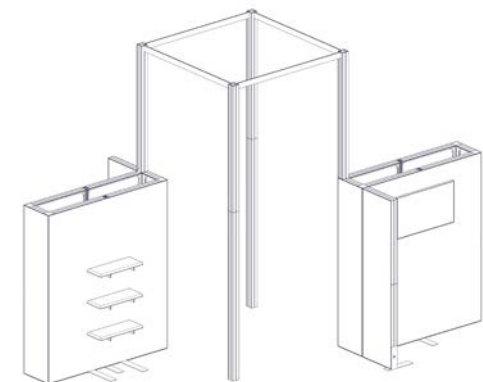
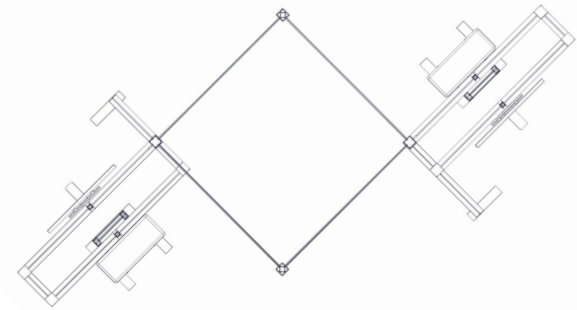

# Exploded Diagram

HP-K-23

## Section 1.1

Reference the Suggested Layout page for build location.

### ATTACH FRAMES TO TOWER

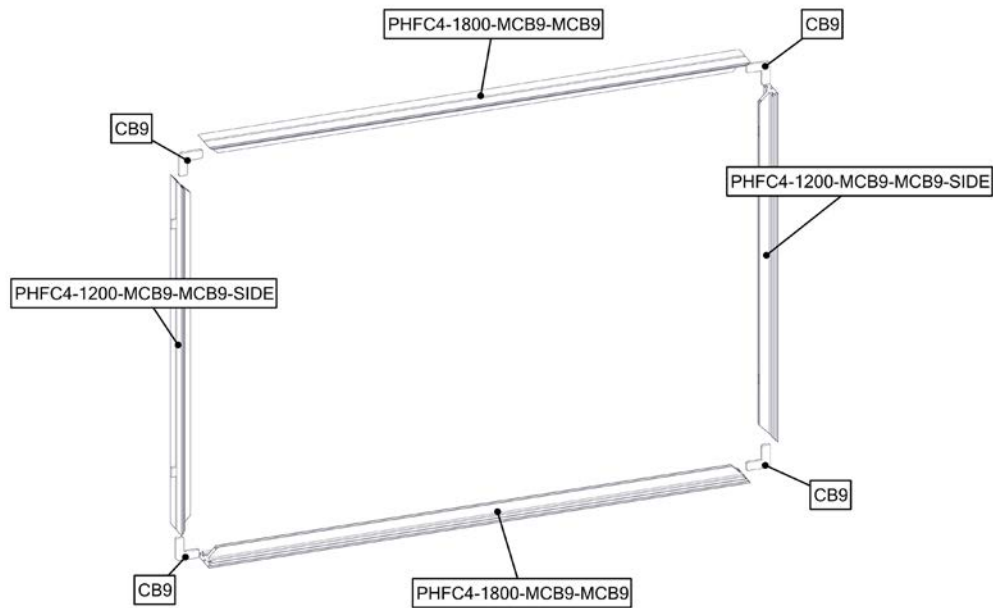
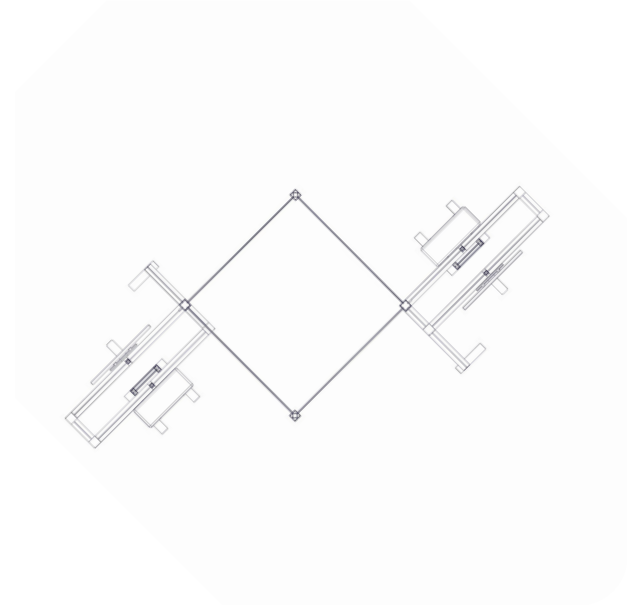
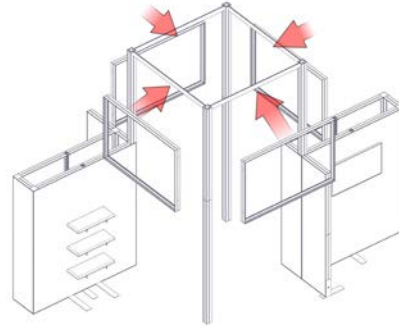

### -ASSEMBLE 4 FRAMES

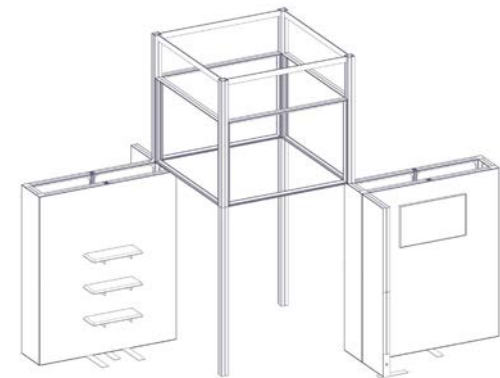

# Exploded Diagram

HP-K-23

## Section 1.1

Reference the Suggested Layout page for build location.

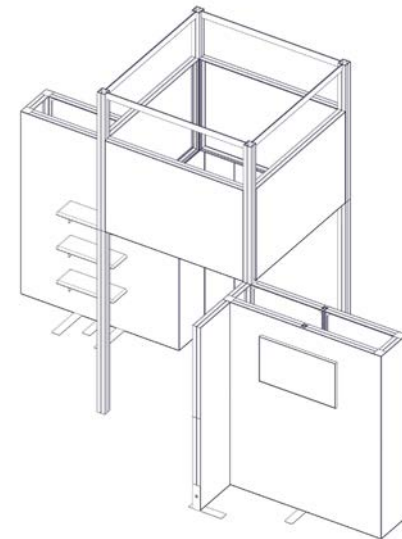
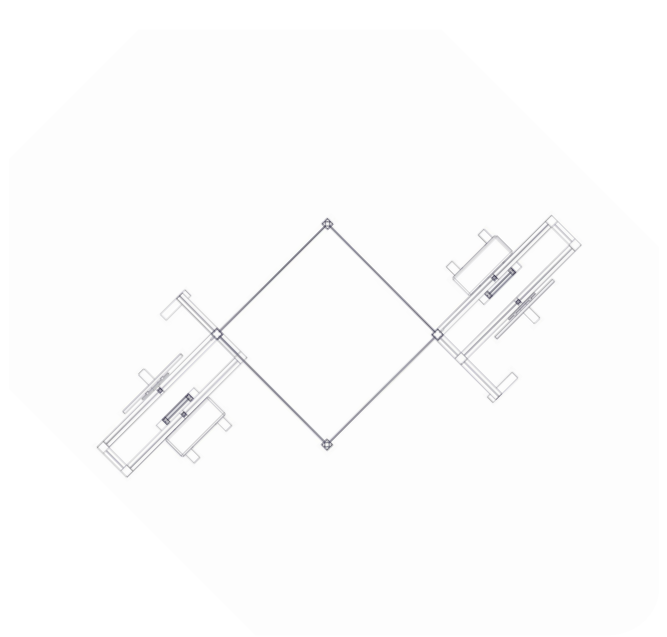
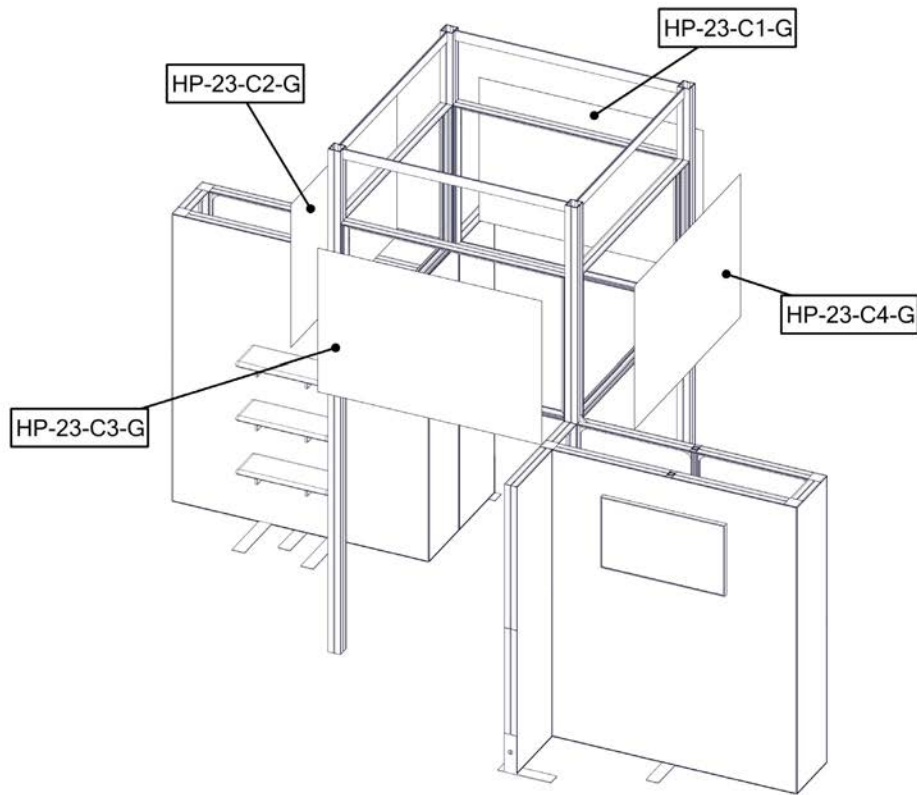

**-ATTACH OUTER GRAPHICS TO TOWER**

# Exploded Diagram

HP-K-23

## Section 1.1

Reference the Suggested Layout page for build location.

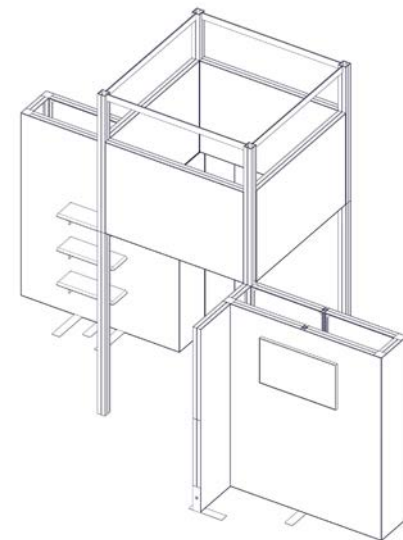
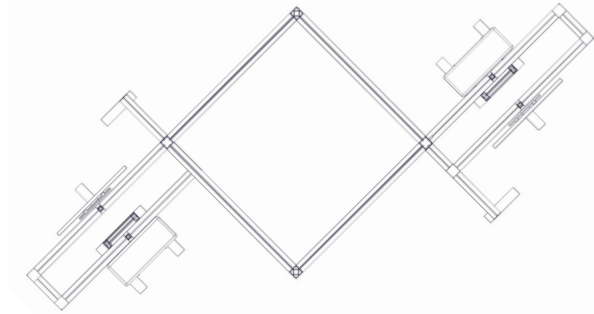
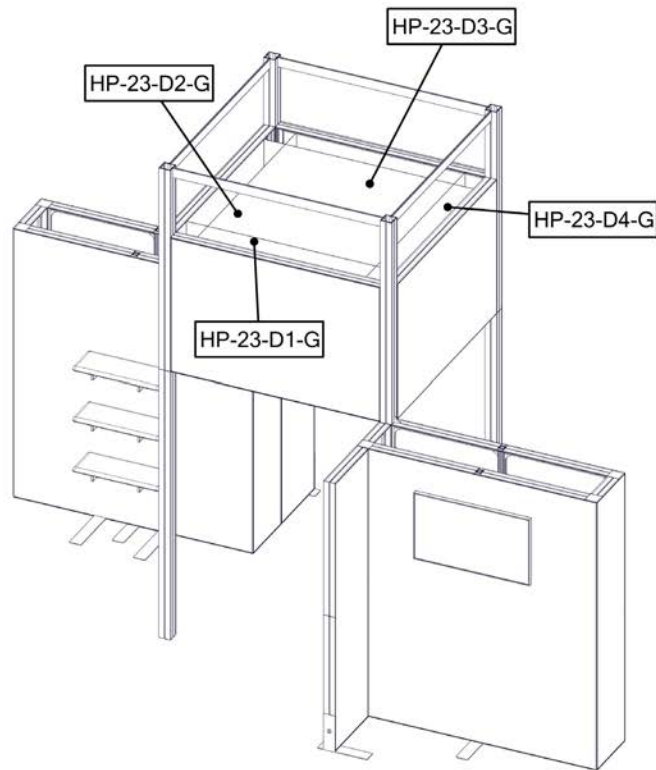

**-ATTACH INSIDE GRAPHICS TO TOWER**



# Labeling Diagram

HP-K-23-SQU

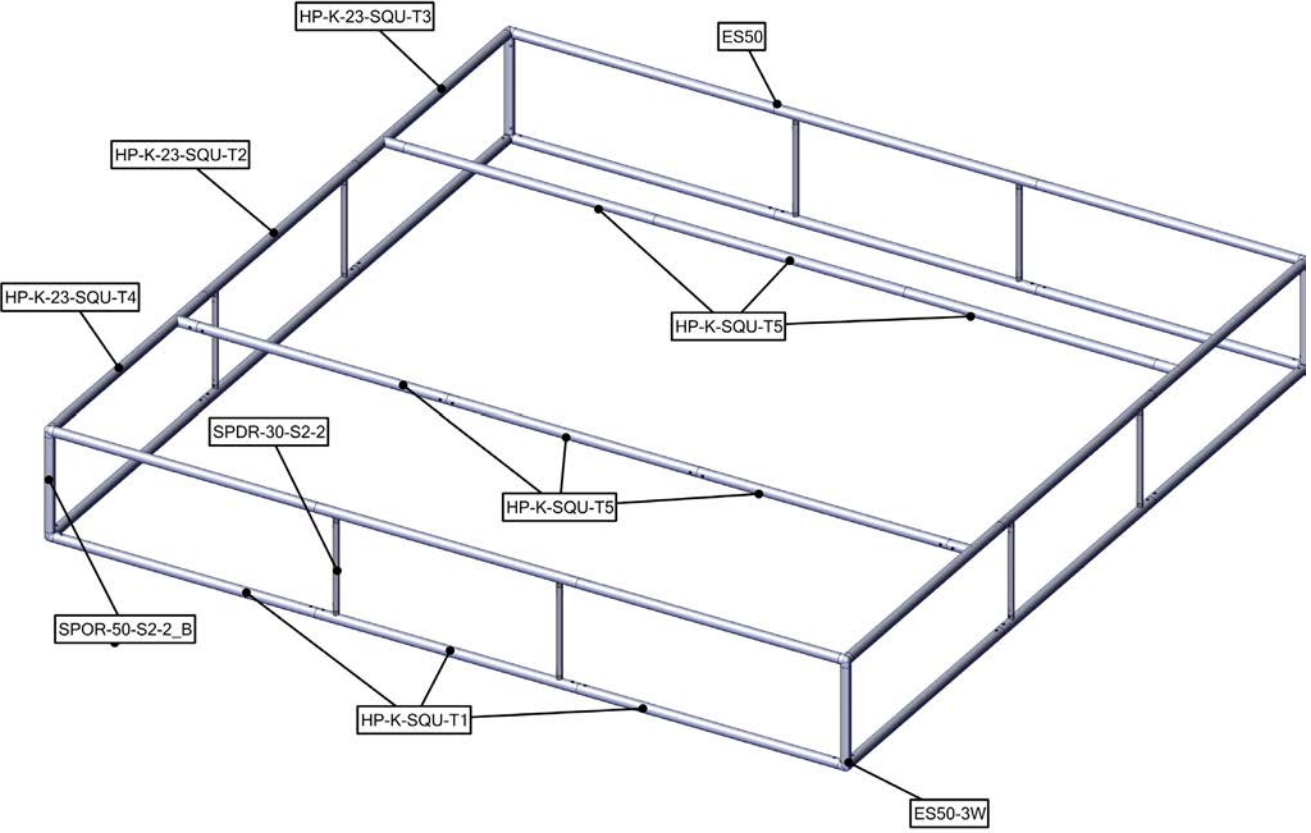

# Labeling Diagram

HP-K-23-SQU

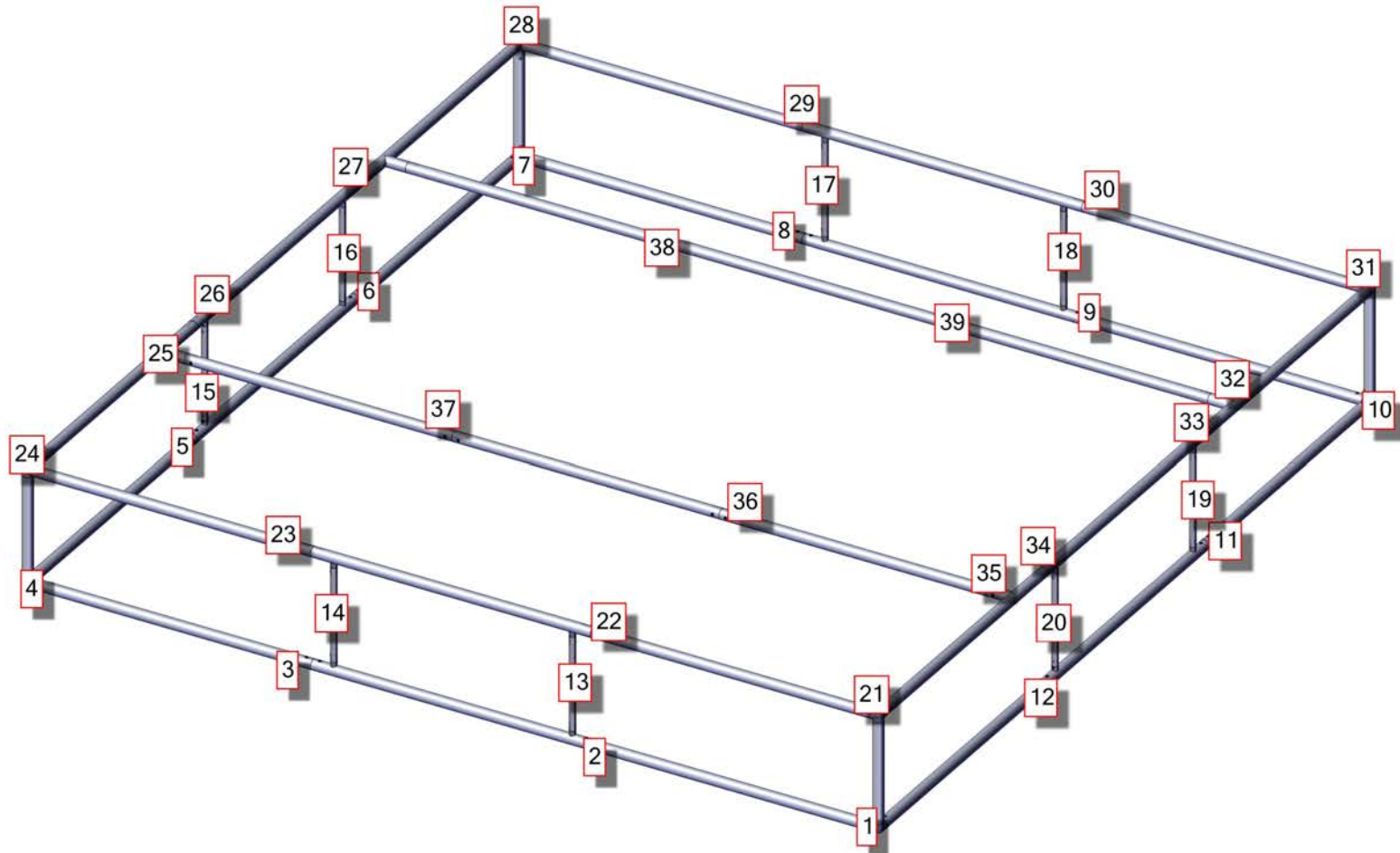

# Exploded Diagram

HP-K-23

## Section 1.2

Reference the Suggested Layout page for build location.

**-ATTACH GRAPHIC TO FRAME**

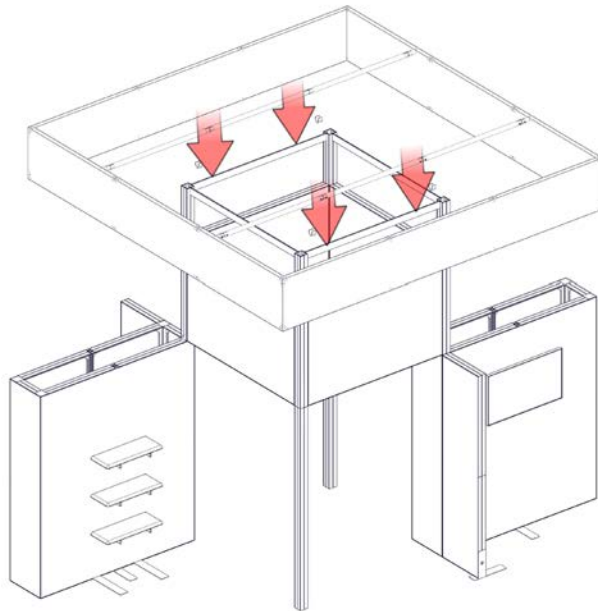
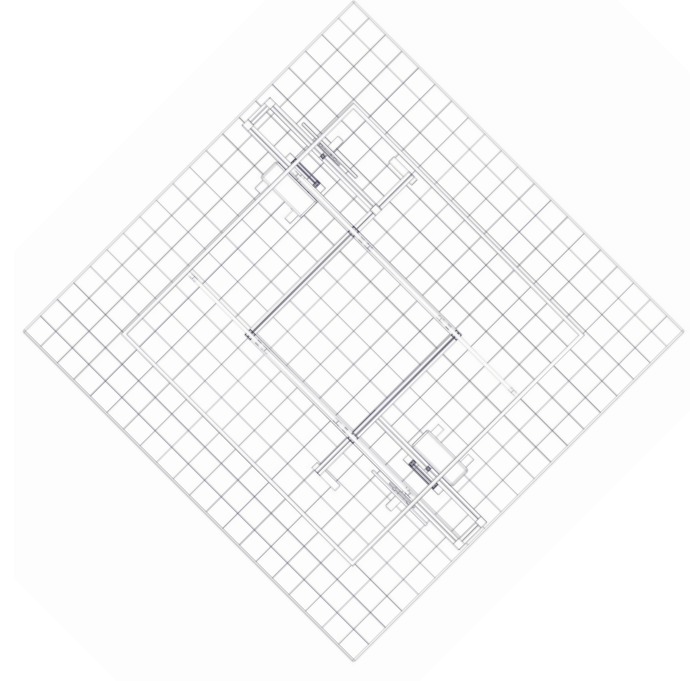
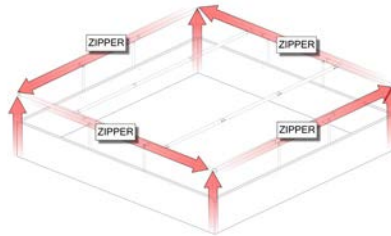

**-ATTACH SQU TO TOP OF TOWER**

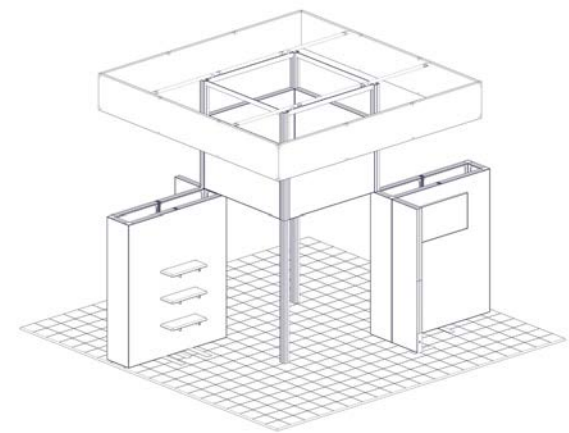

# Exploded Diagram

HP-K-23

## Section 1.2

Reference the Suggested Layout  
page for build location.

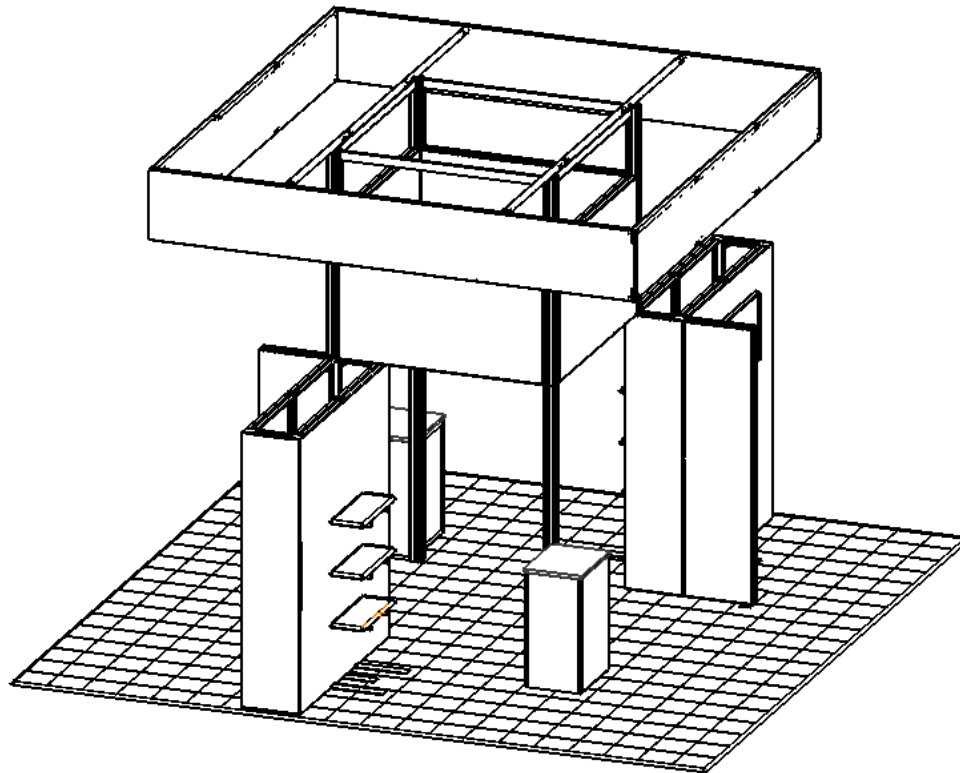

**-ASSEMBLE HPC-15**

**-ATTACHED PDF WITH DETAILED  
ASSEMBLY INSTRUCTIONS**

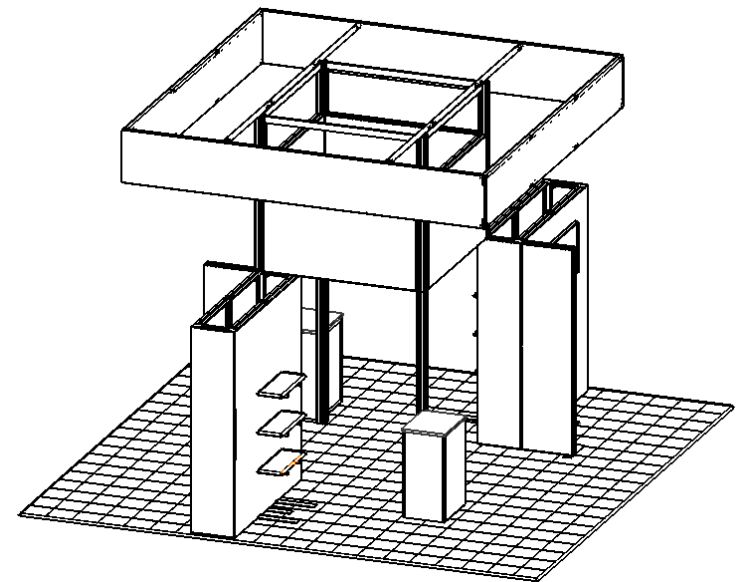
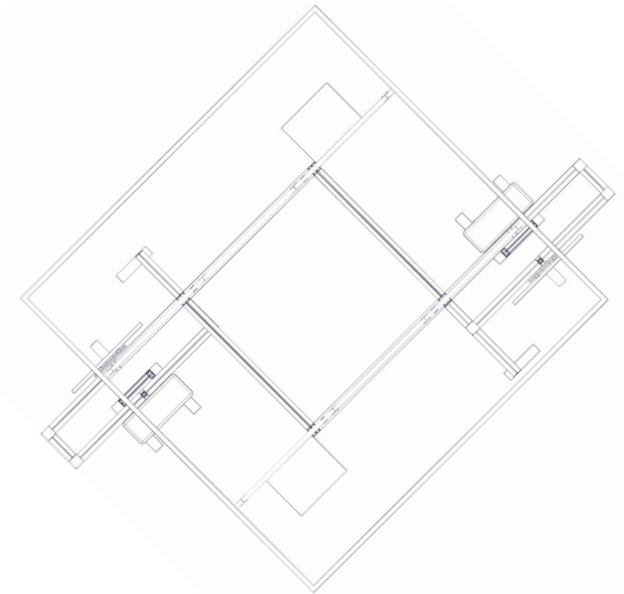

# Suggested Kit Layout

HP-K-23

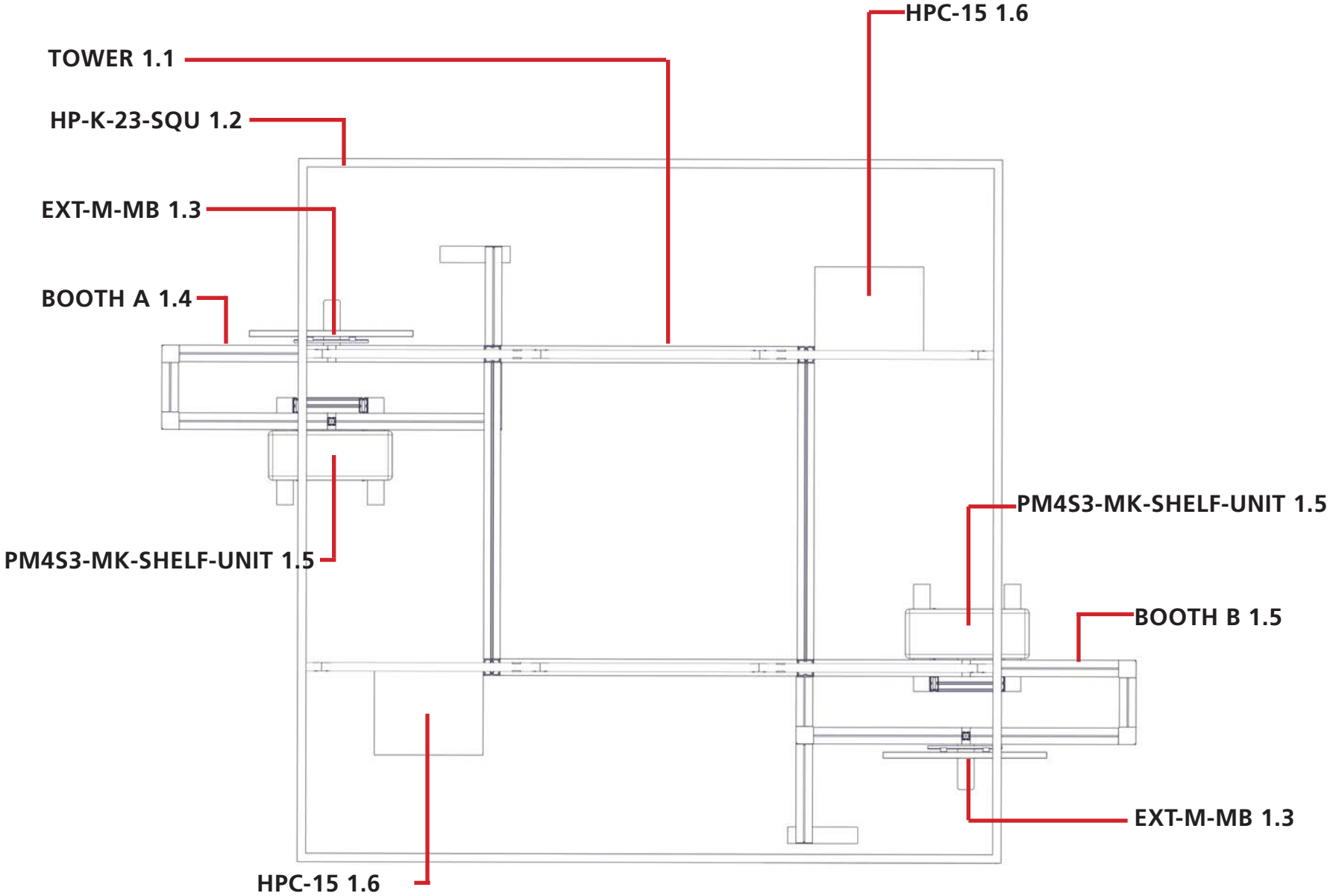

# Kit Assembly

## Step by Step

### Step 1.

Gather the components to build the lower section of main frame. Use the Exploded View and the Labeling Diagram for part labels.

Reference Connection Method(s) 2, 4, 5, 9, 10, and 19 for more details.



### Step 2.

Gather the components to build the upper section of main frame. Use the Exploded View and the Labeling Diagram for part labels.

Reference Connection Method(s) 2, 4, 5, 9, and 10 for more details.

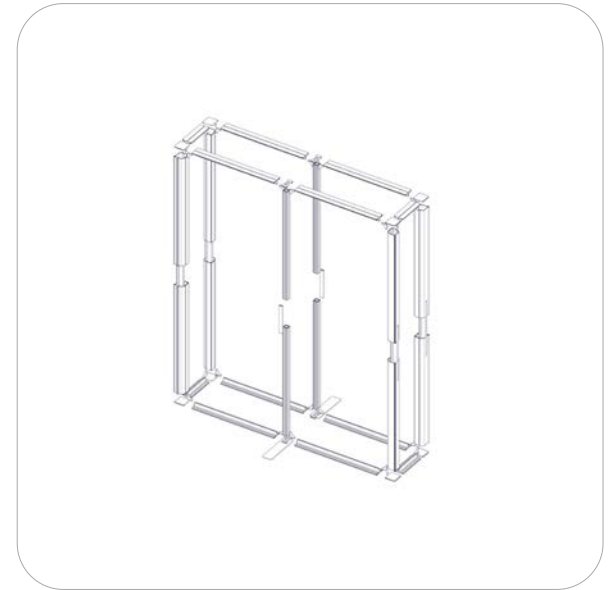

### Step 3.

Gather the components to build the side wing frames for 2 frames. Use the Exploded View and the Labeling Diagram for part labels.

Reference Connection Method(s) 1, 2, 11, and 20 for more details.



### Step 4.

Attach wing frame to main frame. Use the Exploded View and the Labeling Diagram for part labels.

Reference Connection Method(s) 14 for more details.

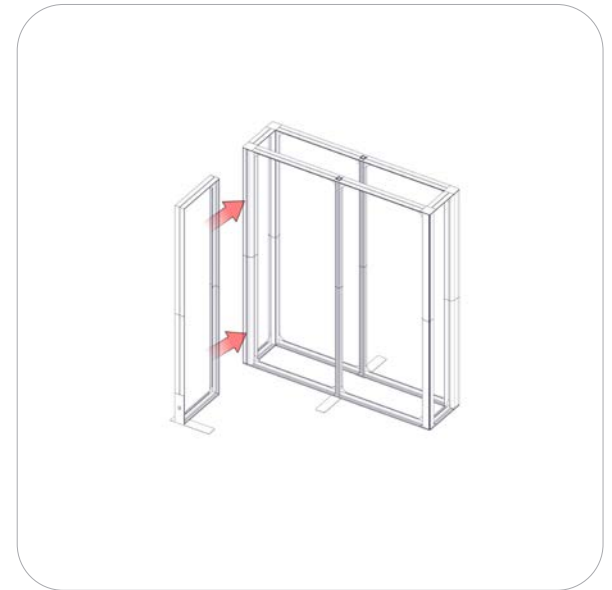

# Kit Assembly

## Step by Step

### Step 5.

Assemble PM4S3-MK-SHELF-UNIT . Use the Exploded View and the Labeling Diagram for part labels.

Reference Connection Method(s)  
See attach PDF with detailed assembly instructions



### Step 6.

Graphic application to main frame and wing

Reference Connection Method(s)  
8 and 16 for more details.

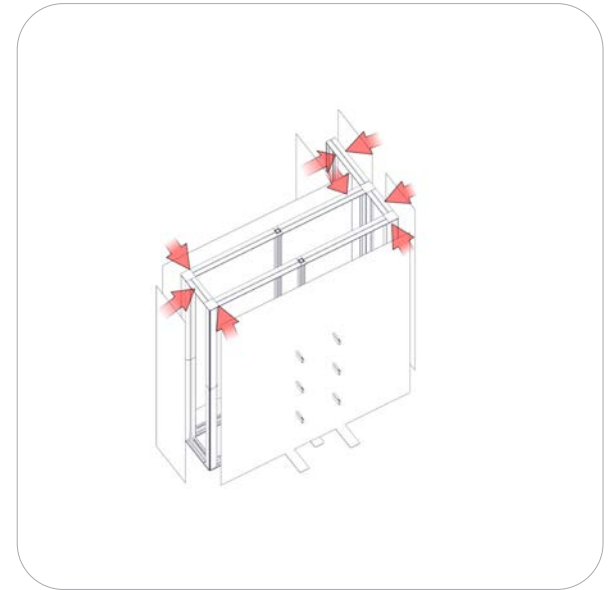

### Step 7.

Attach monitor mount. Use the Exploded View and the Labeling Diagram for part labels.

Reference Connection Method(s)  
15 for more details.

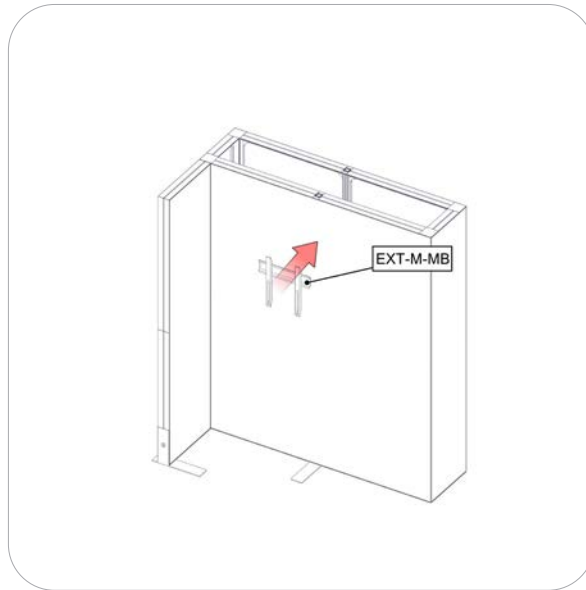

### Step 8.

Assemble tower structure. Use the Exploded View and the Labeling Diagram for part labels.

Reference Connection Method(s)  
2, 12, and 13 for more details.

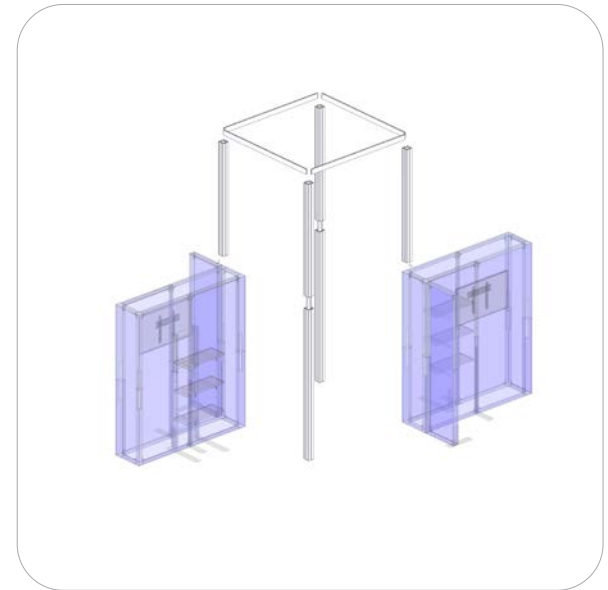

# Kit Assembly

## Step by Step

### Step 9.

Gather the components to build the vector frames to be attached inside tower. Use the Exploded View and the Labeling Diagram for part labels.

Reference Connection Method(s) 1 for more details.

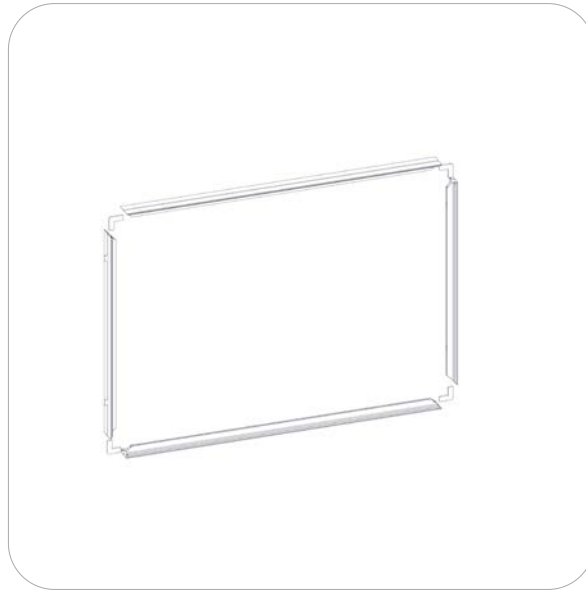

### Step 10.

Attach all 4 frame to upper tower. Use the Exploded View and the Labeling Diagram for part labels.

Reference Connection Method(s) 14 for more details.

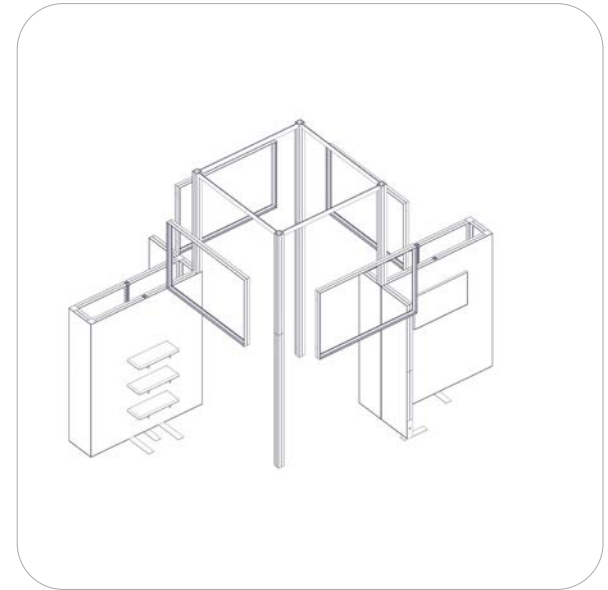
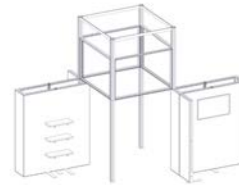

### Step 11.

Attach graphics to outer frames. Use the Exploded View and the Labeling Diagram for part labels.

Reference Connection Method(s) 8 for more details.

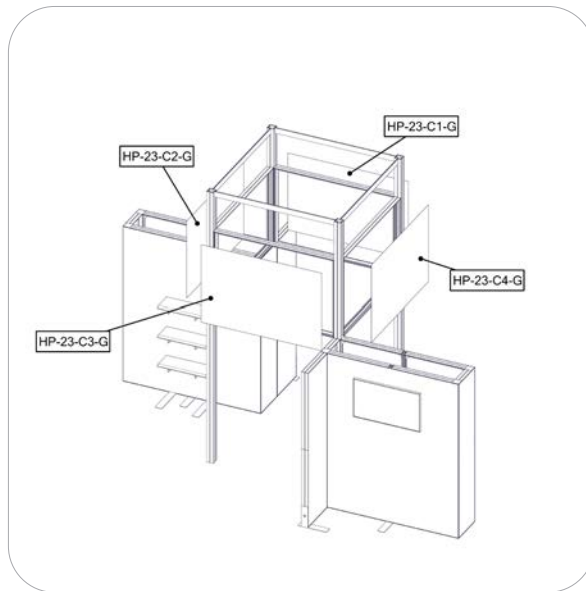

### Step 12.

Attach graphics to inner frames. Use the Exploded View and the Labeling Diagram for part labels.

Reference Connection Method(s) 8 for more details.

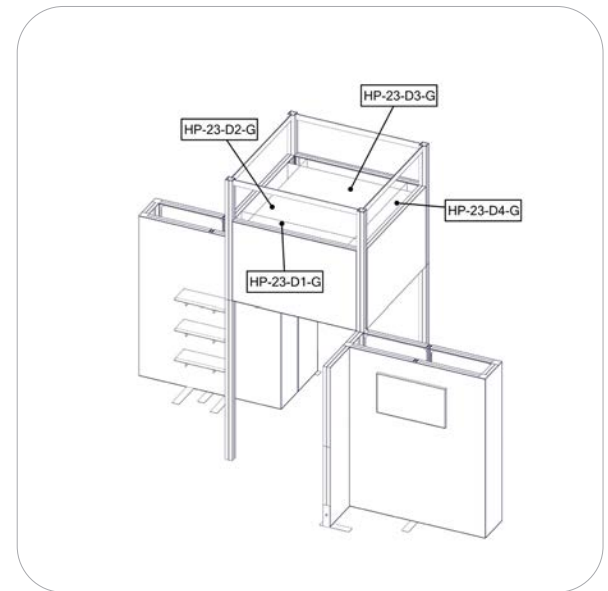
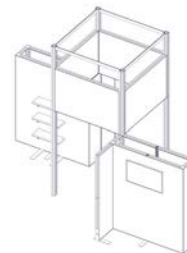



# Kit Assembly

## Step by Step

### Step 13.

Gather the components to build the SQUARE tube frame. Use the Exploded View and the Labeling Diagram for part labels.

Reference Connection Method(s) 6, 7, and 21 for more details.

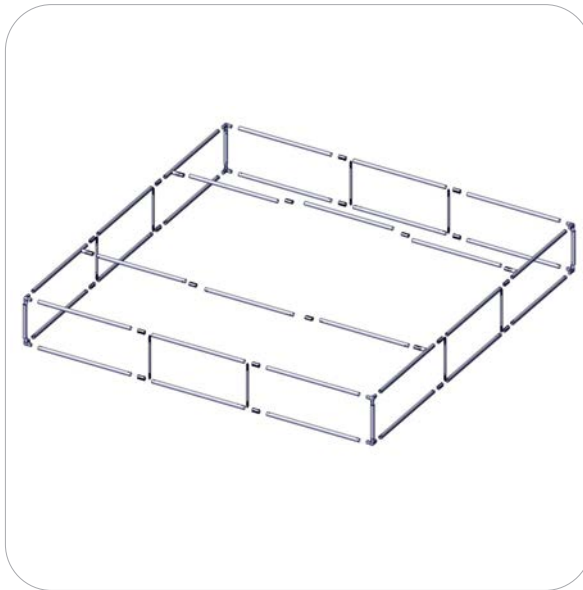

### Step 14.

Attach graphic to tube structure. Use the Exploded View and the Labeling Diagram for part labels.

Reference Connection Method(s) 17 for more details.

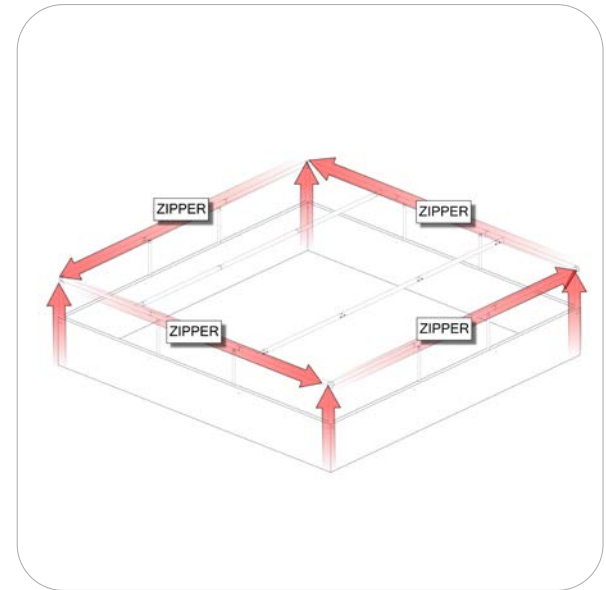
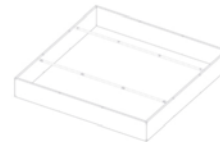

### Step 15.

Connect SQUARE tube structure to top of tower with 4 TC-50-SILVER clamps. Use the Exploded View and the Labeling Diagram for part labels.

Reference Connection Method(s) 18 for more details.

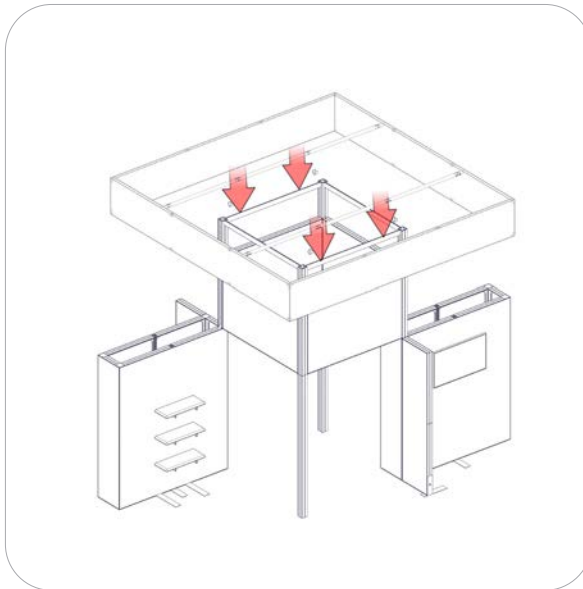
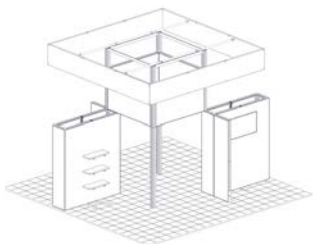

### Step 16.

Assemble counter HPC-15. Use the Exploded View and the Labeling Diagram for part labels.

Reference Connection Method(s) See attach PDF with detailed instructions on assembly of counters to follow.

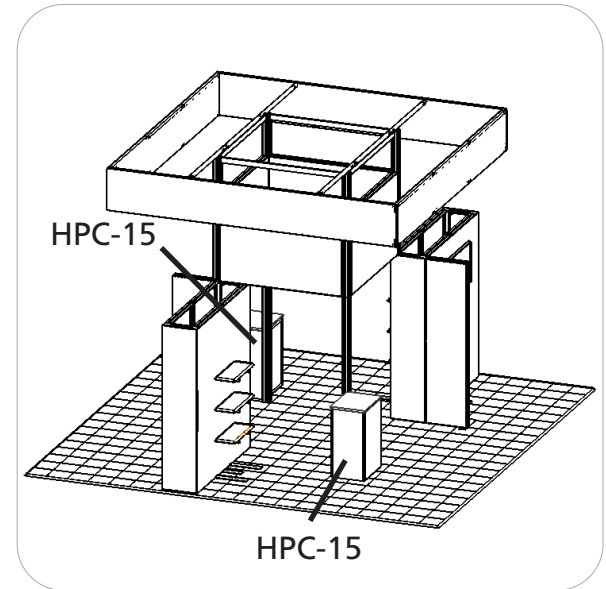
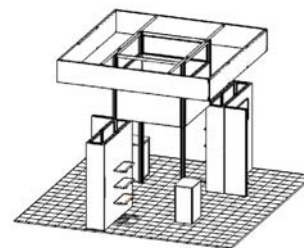

# Assemble Instructions for HPC-15

HP-K-23

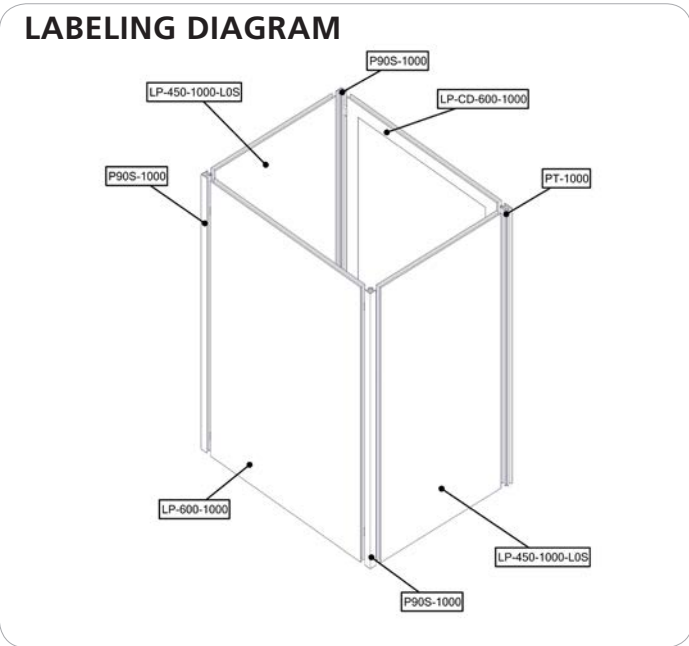
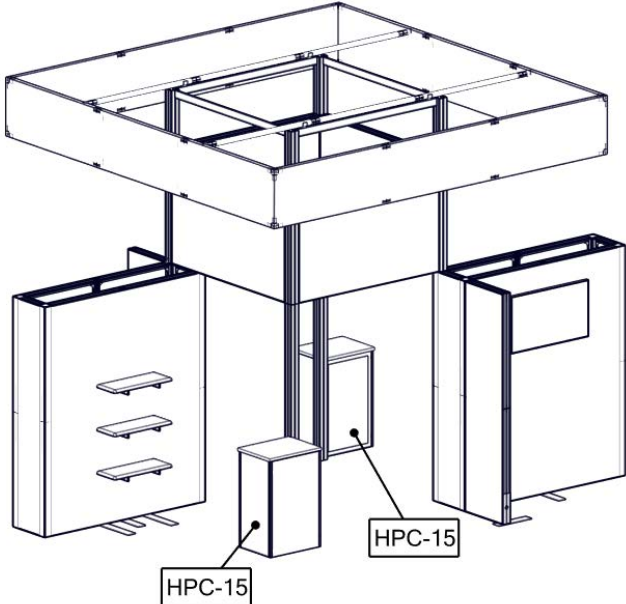

**SET 1**

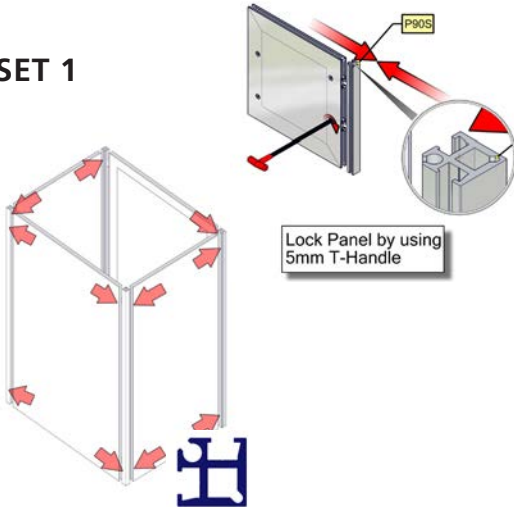

**SET 2**

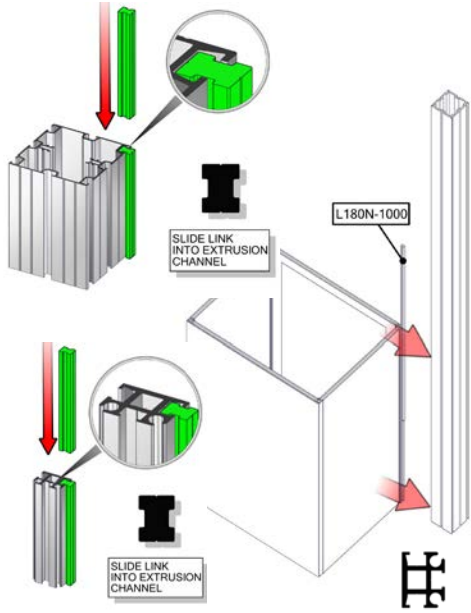

**SET 3**

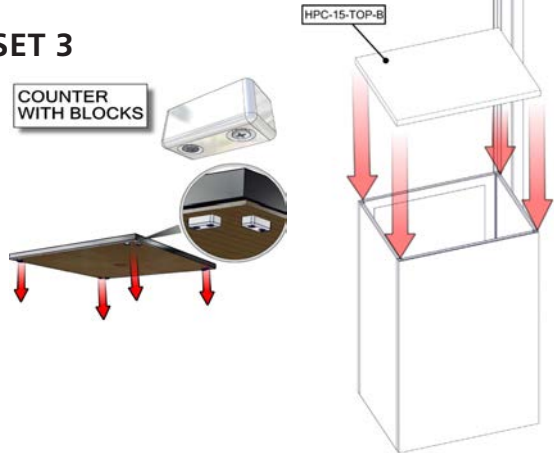

# Connection Methods

## Connection Method 1: CB9



First, insert the corner connector into the extrusion while holding in the lock button with the allen key tool. Second, slide the next extrusion onto the same corner connector while holding in the lock button using the allen key tool. Third, use the allen key tool for locking the corner connector buttons in place. Use the allen key tool to make half turns clock-wise. Do not over tighten the lock buttons.

## Connection Method 2: CBE-50

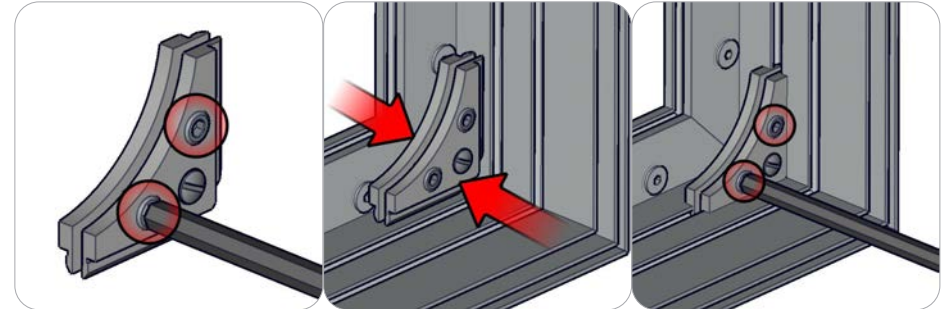

First, use the provides hex tool to loosen the two 5mm hex set screws. Next, compress the bracket and apply it to the corner channel. Then, tighten the set screws. Do not over tighten the set screws. Do not loosen the spring loaded screw.

## Connection Method 3: PM4DSC

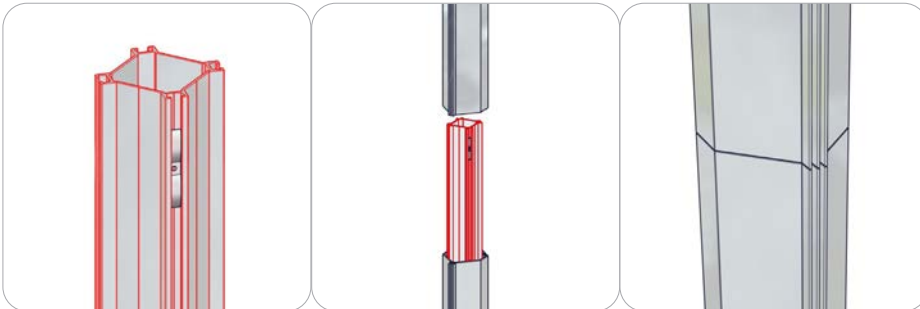

First, take the PM4DSC connector and align it with the internal channels of the next extrusion. Second, slide the connector into the inside channels of the extrusion. The tension glides on the connector will keep it center and snug. The extrusion will have stop pins pre installed to stop it from sinking in. Third, take the next extrusion and apply it on top of the connector completing your connection.

## Connection Method 4: PMF4-90

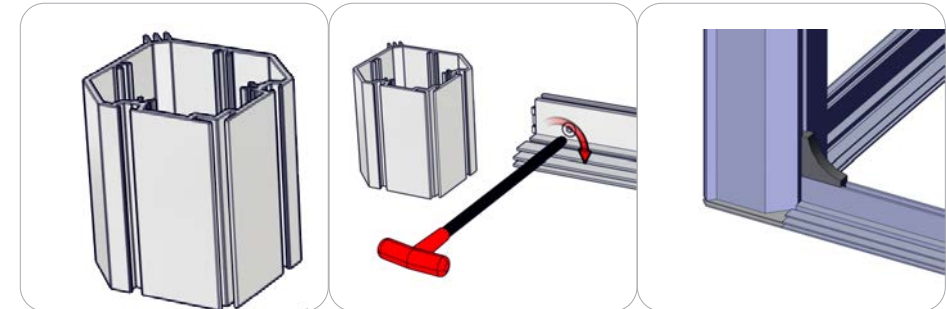

First, loosen the thumb screws and channel bars on the stabilizing bases. Do not disassemble them. Second, slide channel bars into the frame channel flush with the base of the frame. Third, tighten the thumb screws and channel bars securing the attachment. Do not over tighten the thumb screws.

# Connection Methods

## Connection Method 5: PMFC-90 CAP

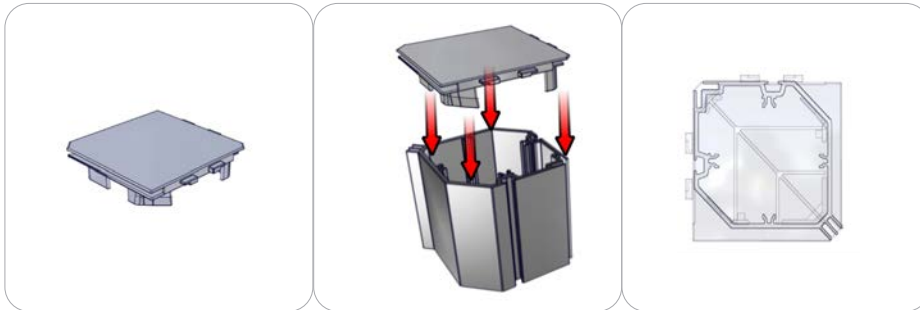

A line plastic clips of cap to extrusion. Once a lined should fit. Do not force cap on, for this could damage the cap.

## Connection Method 6: ES50-3W

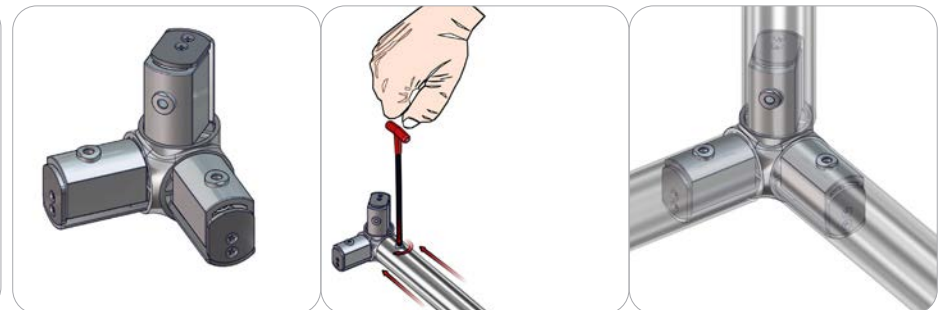

First, check if the connector ends compress. If they do not compress, use the allen key tool for turning the internal screw counter clockwise. Second, compress the connector end and slide it into the tube. Align the connector end button with the tube hole until it pops out. Third, use the allen key tool for turning the internal screw clockwise for a secure fit. Be sure to lock securely, but do not over tighten.

## Connection Method 7: TC-50-D

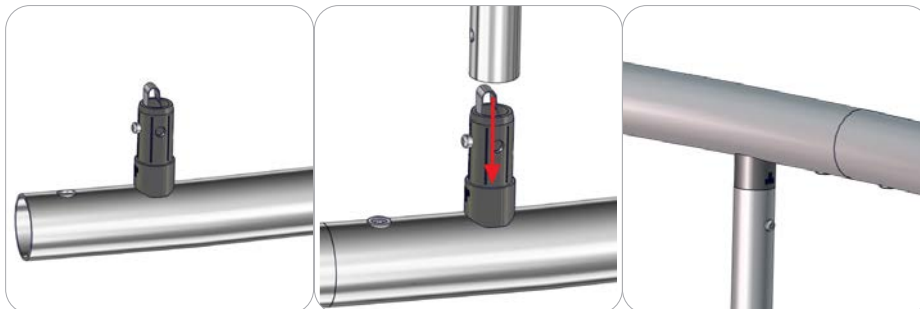

First, check if the connector ends compress. If they do not compress, use the allen key tool for turning the internal screw counter clockwise. Second, compress the connector end and slide it into the tube. Align the connector end button with the tube hole until it pops out. Third, use the allen key tool for turning the internal screw clockwise for a secure fit. Be sure to lock securely, but do not over tighten. Attach a snap button tube to the plastic connector.

## Connection Method 8: Graphic Application

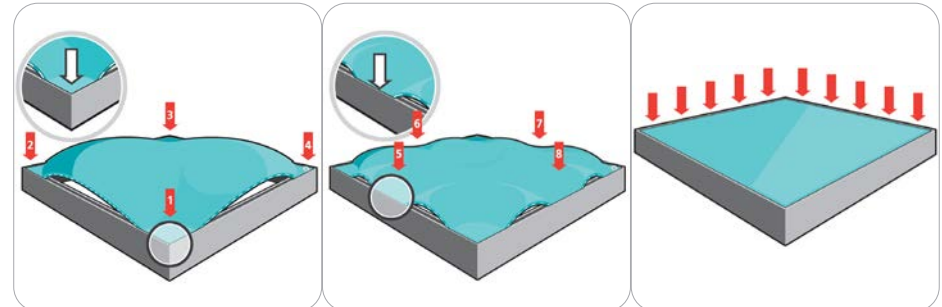

First, insert the silicone edge frame corners into the frame graphic channel (points 1 through 4). Second, insert the silicone edge frame sides into the frame graphic channel (points 5 through 8). Third, push the remaining silicone edge fabric into the frame graphic channel. Similar setup is recommended for the opaque liner. To remove these panels, simply pull the loop tag sewn near a corner.

# Connection Methods

## Connection Method 9: PMFC-90 CAP

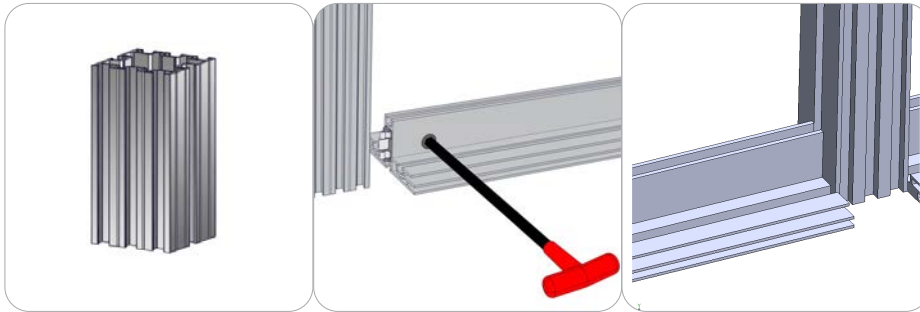

First, make sure lock is loose in the PHFC4. Once loosed, insert into the desired channel on the PM2S2. Second, part is in place, now tighten cam lock til part is firmly in place. Do not over tighten. This could cause damage to parts.

## Connection Method 10: FC-50-SPCR

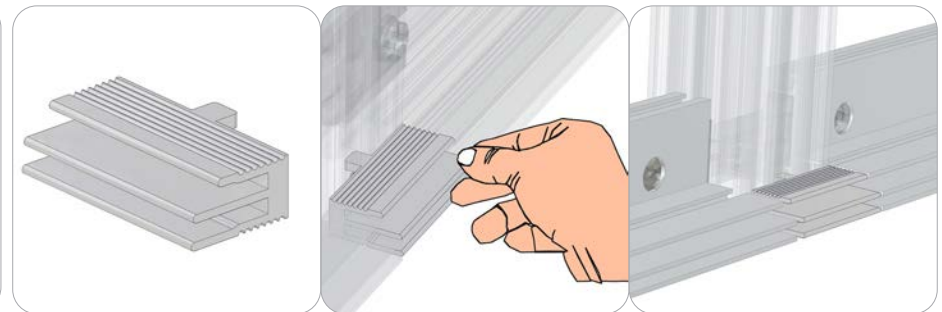

Insert FC-50-SPCR center channel. Make sure it is lined with PHFC4.

## Connection Method 11: SW-FOOT-650

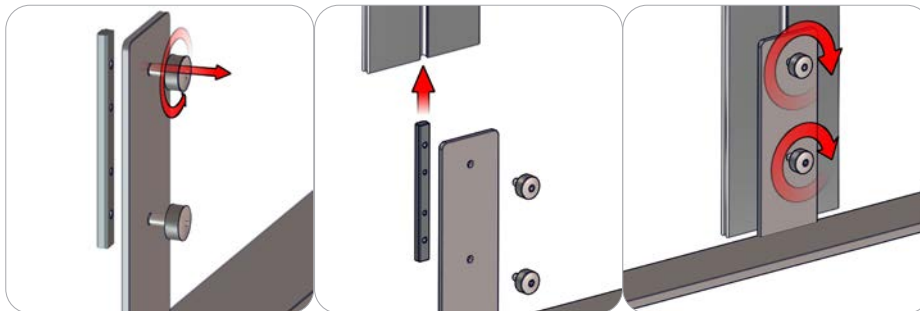

First, loosen the thumb screws and channel bars on the stabilizing bases. Do not disassemble them. Second, slide channel bars into the frame channel flush with the base of the frame. Third, tighten the thumb screws and channel bars securing the attachment. Do not over tighten the thumb screws.

## Connection Method 12: PM4DSC

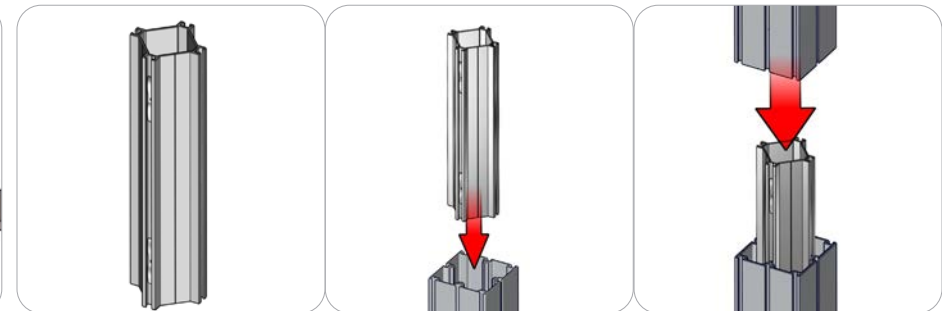

First, take the PM4DSC connector and align it with the internal channels of the next extrusion. Second, slide the connector into the inside channels of the extrusion. The tension glides on the connector will keep it center and snug. The extrusion will have stop pins pre installed to stop it from sinking in. Third, take the next extrusion and apply it on top of the connector completing your connection.

# Connection Methods

## Connection Method 13: PM2S2 to PH2

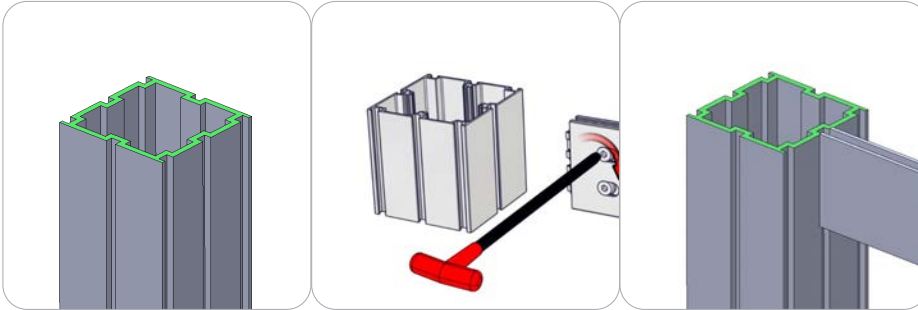

First, make sure lock is loose in the PH2. Once loosened, insert into the desired channel on the PM2S2. Second, part is in place, now tighten cam lock til part is firmly in place. Do not over tighten. This could cause damage to parts.

## Connection Method 14: CAM-LOCK

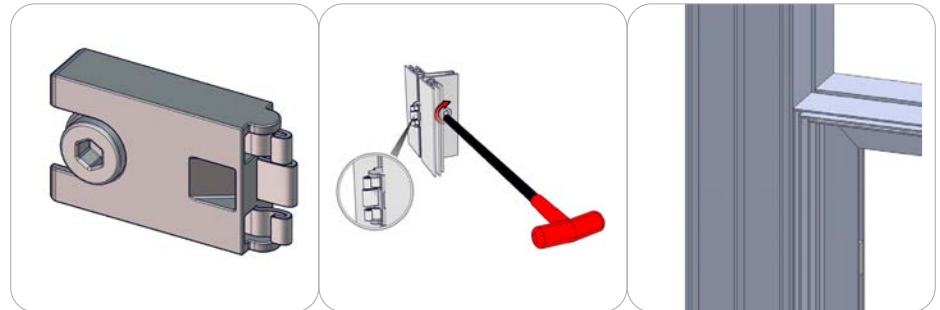

First, with the cam lock disengaged, place the cam lock teeth into the extrusion channel. Second, use the allen key tool to lock it in place. Make half turns clock-wise to engage the cam lock. Do not over tighten the lock buttons.

## Connection Method 15: EXT-M-MB



First, use hardware shown to attach plate to the PM2S2. Second, attach motion arms. (They hold monitor in place). Third, double check all connections are tightened and secure. You are ready to attach monitor. Its best to remove arms, attach them to the monitor first. Then, attach it to plate.

## Connection Method 16: PM4DSC

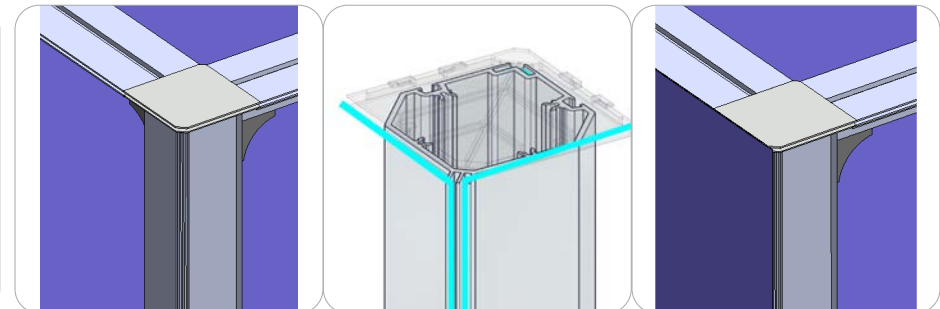

First, attach graphic into proper channel. Once in channel pull tight til you reach channel on the opposite side. Push graphic into channel. Smooth out wrinkles if needed.

# Connection Methods

## Connection Method 17: ATTACH SQU GRAPHIC

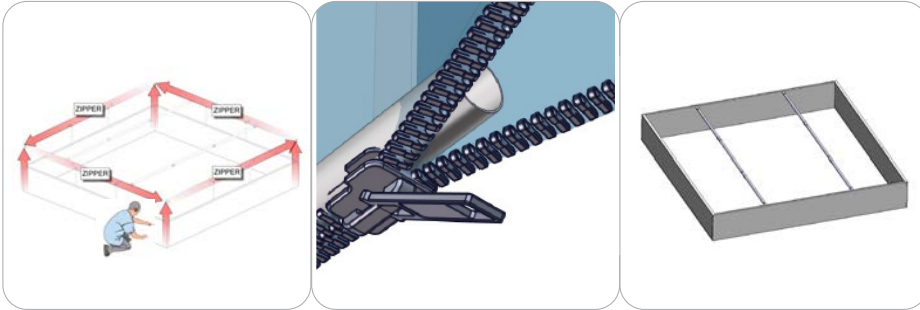

First, flip the frame upside down. place graphic over tubing. Once in place you can start to stretch fabric in place. Graphic is now in its desired placement. Now, using the zipper close the graphic.

## Connection Method 18: TC-50MM-SILVER

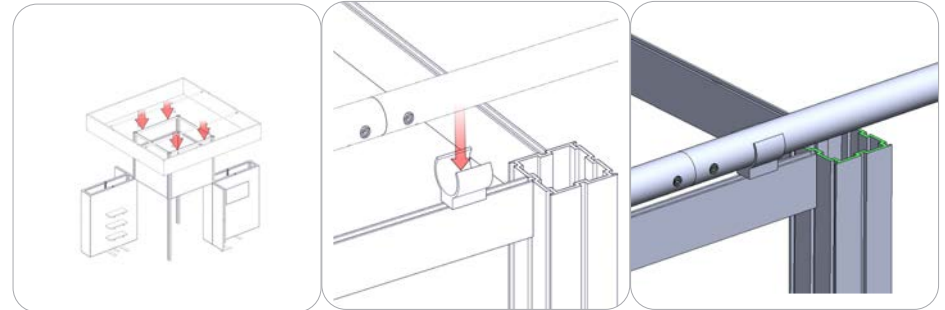

First, attach TC-50-SILVER clamp to PH2. Second, Lock TC-50-SILVER in place. Third, Place SQUARE frame in all 4 clamps. Once in place adjust it as needed.

## Connection Method 19: ATTACH SQU GRAPHIC

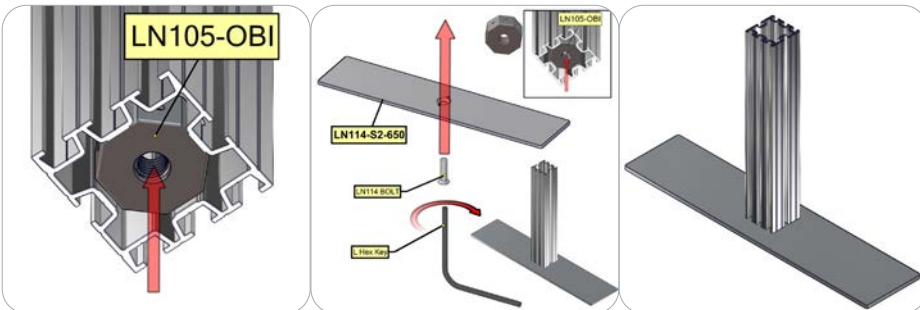

First, line up part needed. insert bolt into nut insert in the PM2S2. Second, once bolt is inserted, tighten. Do not over tighten this could cause damage or stripe out threads of nut insert.

## Connection Method 20: IB2



First, insert the in-line connector into the extrusion while holding in the lock button with the allen key tool. Second, slide the next extrusion onto the same in-line connector while holding in the lock button using the allen key tool. Third, use the allen key tool for locking the in-line connector buttons in place. Use the allen key tool to make half turns clock-wise. Do not over tighten the lock buttons.

# Connection Methods

## Connection Method 21: ES50

---

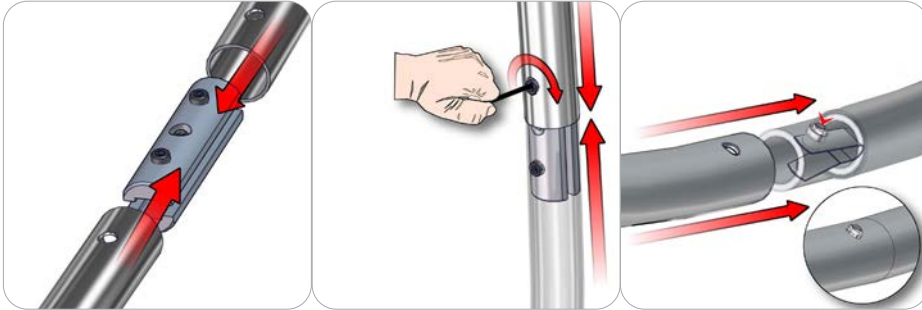

For spigot connections, compress the unlocked connector and slide into the tube lock access hole. Lock both screws carefully using your allen key tool. Be sure to lock securely, but do not over tighten. For snap button connections, locate the snap button on the connector or swage tube. Locate the hole on the corresponding tube. Press the snap button with your thumb and slide the tube and connector together so that the snap button snaps fully into the lock hole. To disassemble, press the snap button and pull apart.

---