

Formulate Half Moon Counter

Formulate counters couple lightweight hardware with printed stretch silicone edge fabric graphics (SEG) to create funky and functional reception stands. Tables and bases are available in four colored finishes – silver, black, mahogany and natural. Custom sizes also available.



features and benefits:

- Printed stretch silicone edge fabric graphics (SEG) for a custom look
- Counter supports 25 lbs. of weight on center
- Choice of four finishes for table and base
- Kit includes: one frame, two dye-sublimated graphics, table and base, and one wheeled molded OCH2 storage case
- Lifetime hardware warranty against manufacturer defects

dimensions:

Hardware	Graphic
<p>Assembled unit: 42" w x 38" h x 18" d 1066mm(w) x 970mm(h) x 457mm(d)</p> <p>Approximate kit weight (includes graphic): 45 lbs / 20.4 kgs</p>	<p>Refer to related graphic template for more information.</p> <p>Visit: www.tradeshowplus.com</p>
Shipping	
<p>Shipping dimensions: One OCH2 case: 50" l x 30" w x 15" h</p> <p>Approximate shipping weight: (kit and case) 75 lbs / 34 kgs</p>	

additional information:

Graphic material:
Dye-sublimated fabric

Top/Base finishes:

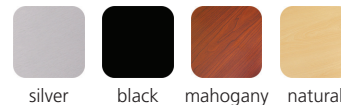

silver black mahogany natural

We are continually improving and modifying our product range and reserve the right to vary the specifications without prior notice. All dimensions and weights quoted are approximate and we accept no responsibility for variance. E&OE. See Graphic Templates for graphic bleed specifications.

Parts Included		
Part Label	Qty	Part Code
5/16-18 WING NUT	x12	5-16-18 WING NUT
5/16-18 X 1.25" STEEL STUD	x6	5_16_18 X 1.25 STUD
5/16-18 X 2" STEEL STUD	x6	5_16_18 X 2 STUD
900MM LENGTH OF TRILOK TRUSS	x2	TRI30-COUNTER
HALF MOON BASE	x1	W-02-BASE
HALF MOON FABRIC GRAPHIC	x1	W-02-G
HALF MOON TOP	x1	W-02-TOP

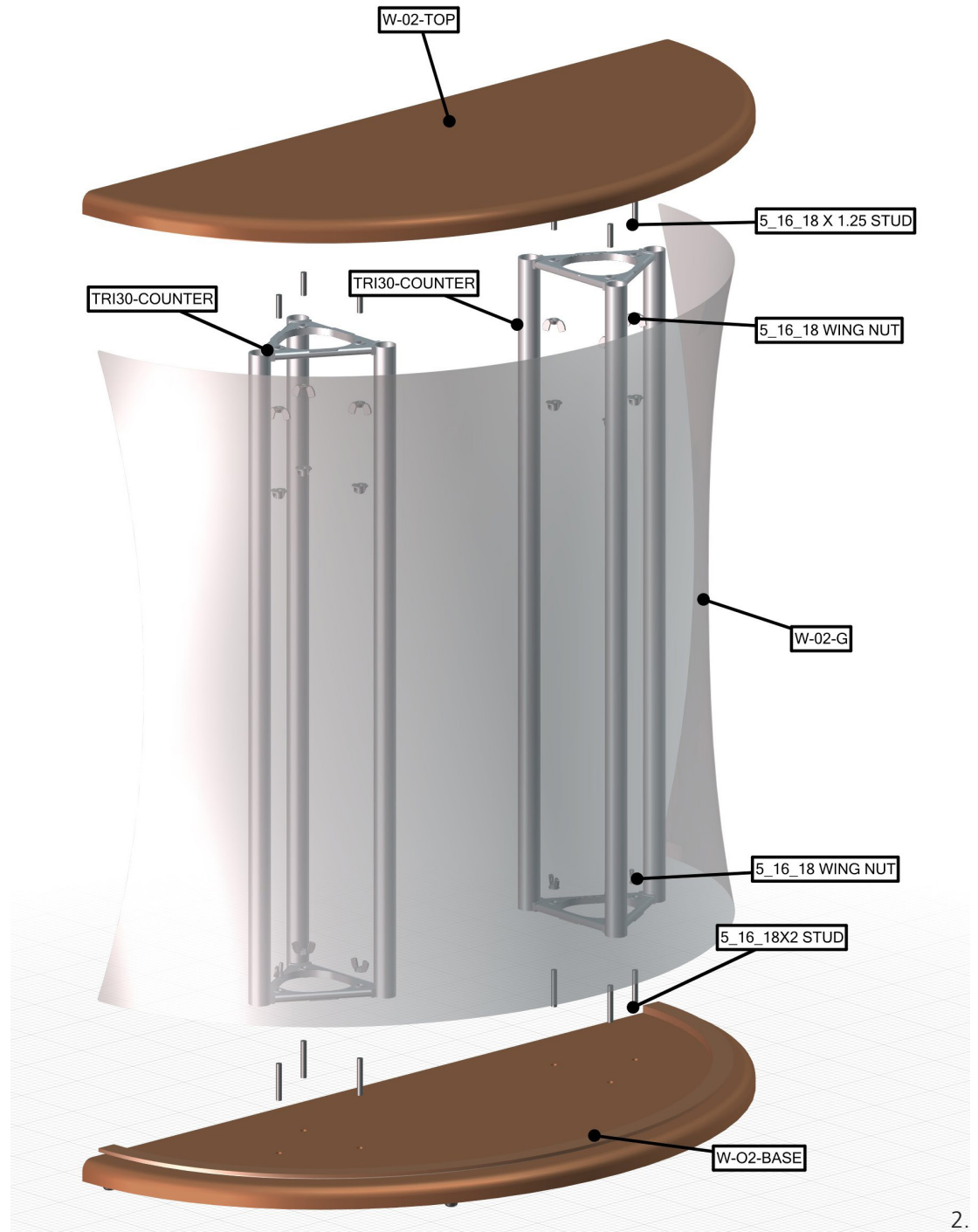
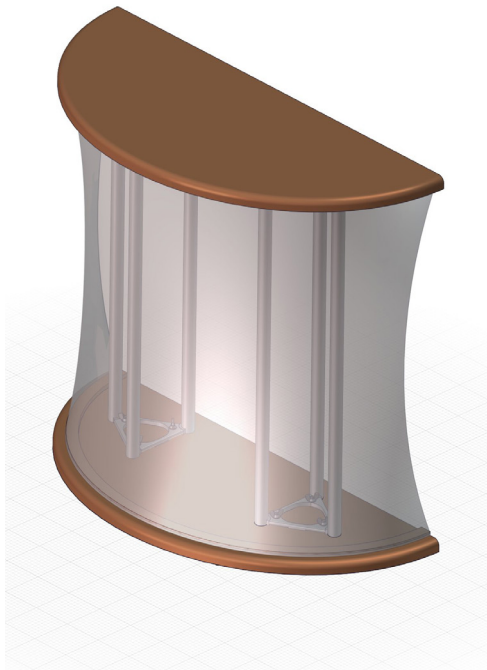

STEP 1: ATTACH BASE

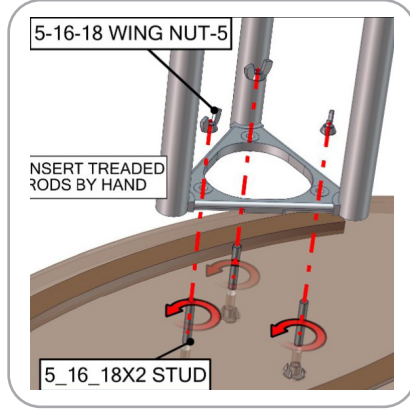
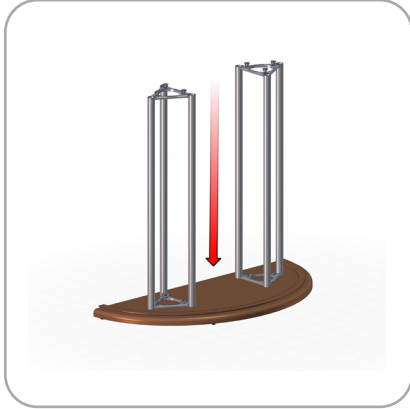

STEP 2: ATTACH TOP

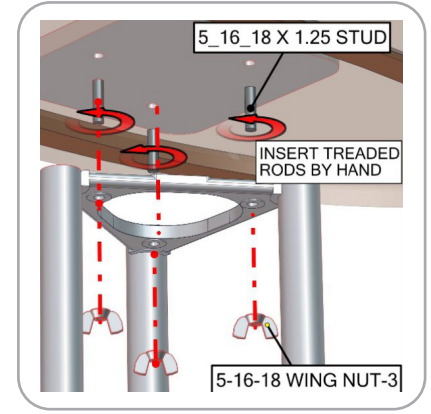
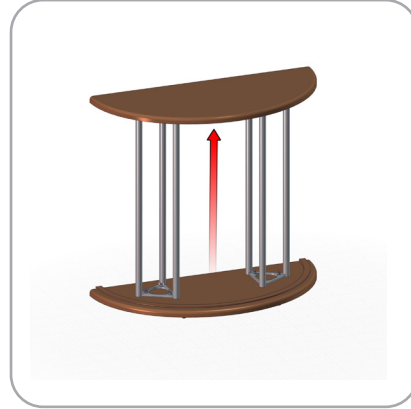

STEP 3: ATTACH GRAPHIC

